

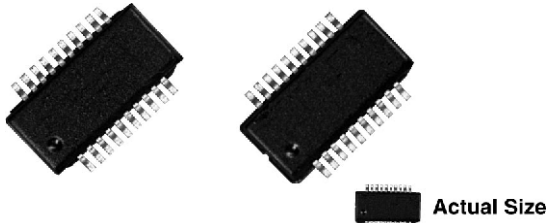

**THE DATASHEET OF  
OSOPTC1001AT0**



## Molded, 25 mil Pitch, Dual-In-Line Thin Film Resistor, Surface Mount Network



OSOP Series resistor networks feature a space saving 25 mil lead pitch versus the current 50 mil pitch standard. This allows users to reduce board space more than 50 % over current standards. The OSOP series features 16, 20, and 24 pin variations with isolated and last pin common schematics. Custom schematics and resistor values are also available, consult factory.

### SCHEMATIC

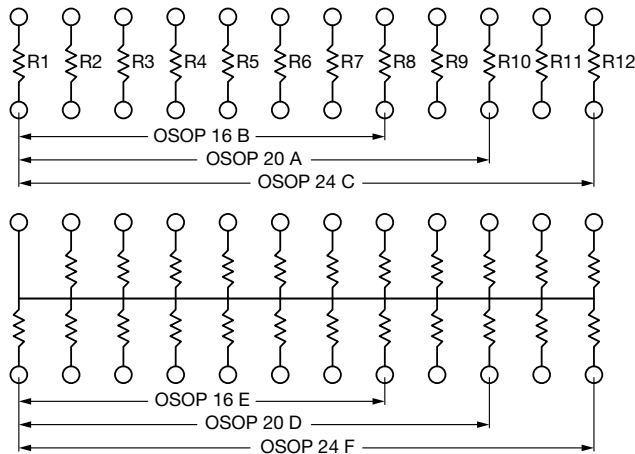

### FEATURES

- 0.068" (1.73 mm) maximum seated height
- Rugged molded case construction with no internal solder
- JEDEC® MO-137 variation AB = 16 pin, AD = 20 pin, AE = 24 pin
- Material categorization: for definitions of compliance please see [www.vishay.com/doc?99912](http://www.vishay.com/doc?99912)



### Note

\* This datasheet provides information about parts that are RoHS-compliant and / or parts that are non RoHS-compliant. For example, parts with lead (Pb) terminations are not RoHS-compliant. Please see the information / tables in this datasheet for details

### TYPICAL PERFORMANCE

	ABSOLUTE TRACKING	
	ABSOLUTE	RATIO
TCR	25	5
TOL.	0.1	0.05

### STANDARD RESISTANCE OFFERING (R<sub>1</sub> =)

500 Ω	10 kΩ
1 kΩ	20 kΩ
2 kΩ	50 kΩ
5 kΩ	100 kΩ

### Note

- Consult factory for additional values and schematics

### STANDARD ELECTRICAL SPECIFICATIONS

TEST	SPECIFICATIONS	CONDITIONS
Material	Passivated nichrome	-
Pin / Lead Number	16, 20, 24	-
Resistance Range	500 Ω to 100 kΩ per resistor	-
TCR: Absolute	± 25 ppm/°C	-55 °C to +125 °C
TCR: Tracking	± 5 ppm/°C	-55 °C to +125 °C
Tolerance: Absolute	± 0.1 % to ± 1 %	+25 °C
Tolerance: Ratio	± 0.025 % to ± 0.5 %	+25 °C
Power Rating: Resistor	100 mW	Maximum at +70 °C
Power Rating: Package	400 mW	Maximum at +70 °C
Stability: Absolute	ΔR ± 0.05 %	2000 h at +70 °C
Stability: Ratio	ΔR ± 0.015 %	2000 h at +70 °C
Voltage Coefficient	< 0.1 ppm/V (typical)	-
Working Voltage	100 V max. not to exceed $\sqrt{P \times R}$	-
Operating Temperature Range	-55 °C to +125 °C	-
Storage Temperature Range	-55 °C to +150 °C	-
Noise	< -30 dB	-
Thermal EMF	0.08 μV/°C	-
Shelf Life Stability: Absolute	ΔR ± 0.01 %	1 year at +25 °C
Shelf Life Stability: Ratio	ΔR ± 0.002 %	1 year at +25 °C

DIMENSIONS AND IMPRINTING in inches and millimeters				
		DIMENSION	INCHES	MILLIMETERS
	A	16 pin	0.193 ± 0.003	4.90
		20, 24 pin	0.341 ± 0.003	8.66
		B	0.154	3.91
		C	0.237	6.02
		D	0.025	0.635
		E	0.010 ± 0.002	0.25 ± 0.05
		F	0.062	1.58
		G	0.068	1.73
		H	0.010 ± 0.002	0.25 ± 0.05
		I	0.025	0.64
J	16 pin	0.009	0.23	
	20 pin	0.057	1.47	
	24 pin	0.033	0.838	

MECHANICAL SPECIFICATIONS	
Resistive Element	Passivated nichrome
Substrate Material	Silicon
Body	Molded epoxy
Terminals	Copper alloy
Lead (Pb)-free Option	100 % matte tin
Tin Lead Option	Sn90
Tin Lead and Lead (Pb)-free Finish	Plated

GLOBAL PART NUMBER INFORMATION																													
New Global Part Numbering: OSOPA1002BUF																													
<table border="0" style="width: 100%; text-align: center;"> <tr> <td>O</td><td>S</td><td>O</td><td>P</td><td>A</td><td>1</td><td>0</td><td>0</td><td>2</td><td>B</td><td>U</td><td>F</td> </tr> <tr> <td>O</td><td>S</td><td>O</td><td>P</td><td>T</td><td>A</td><td>1</td><td>0</td><td>0</td><td>3</td><td>A</td><td>T</td><td>1</td> </tr> </table>					O	S	O	P	A	1	0	0	2	B	U	F	O	S	O	P	T	A	1	0	0	3	A	T	1
O	S	O	P	A	1	0	0	2	B	U	F																		
O	S	O	P	T	A	1	0	0	3	A	T	1																	
GLOBAL MODEL (4 or 5 digits)	SCHEMATIC	RESISTANCE	TOLERANCE AND RATIO TOLERANCE	PACKAGING																									
<b>OSOP</b> (Tin Lead)  <b>OSOPT</b> (Lead (Pb)-free) (e3)	<b>A</b> = 20 pin 10 isolated resistors <b>B</b> = 16 pin 8 isolated resistors <b>C</b> = 24 pin 12 isolated resistors  <b>D</b> = 20 pin 19 resistors pin 20 common <b>E</b> = 16 pin 15 resistors pin 16 common <b>F</b> = 24 pin 23 resistors pin 24 common	First 3 digits are significant figures and the last digit specifies the number of zeroes to follow.  Example: 1002 = 10K 1003 = 100K	<table border="0"> <tr> <td>Abs. Tol.</td> <td>Ratio</td> </tr> <tr> <td><b>A</b> = 0.1 %</td> <td>0.05 %</td> </tr> <tr> <td><b>B</b> = 0.1 %</td> <td>0.1 %</td> </tr> <tr> <td><b>C</b> = 0.25 %</td> <td>0.1 %</td> </tr> <tr> <td><b>D</b> = 0.5 %</td> <td>0.1 %</td> </tr> <tr> <td><b>F</b> = 1 %</td> <td>0.5 %</td> </tr> <tr> <td><b>Z</b> = 0.1 % <sup>(1)</sup></td> <td>0.025 %</td> </tr> </table>	Abs. Tol.	Ratio	<b>A</b> = 0.1 %	0.05 %	<b>B</b> = 0.1 %	0.1 %	<b>C</b> = 0.25 %	0.1 %	<b>D</b> = 0.5 %	0.1 %	<b>F</b> = 1 %	0.5 %	<b>Z</b> = 0.1 % <sup>(1)</sup>	0.025 %	TAPE AND REEL <b>T0</b> = 100 min., 100 mult <b>T1</b> = 1000 min., 1000 mult <sup>(2)</sup> <b>T3</b> = 300 min., 300 mult <b>T5</b> = 500 min., 500 mult <b>TF</b> = Full reel 2500 <b>TS</b> = 100 min., 1 mult  <b>UF</b> = TUBED											
Abs. Tol.	Ratio																												
<b>A</b> = 0.1 %	0.05 %																												
<b>B</b> = 0.1 %	0.1 %																												
<b>C</b> = 0.25 %	0.1 %																												
<b>D</b> = 0.5 %	0.1 %																												
<b>F</b> = 1 %	0.5 %																												
<b>Z</b> = 0.1 % <sup>(1)</sup>	0.025 %																												
Historical Part Number example: OSOPA5000B (for reference purposes only)																													
OSOP	A	5000	B																										
SERIES	SCHEMATIC	RESISTANCE	TOLERANCE AND RATIO TOLERANCE																										

**Notes**

- (1) Tolerance available 1K and up  
 (2) Preferred packaging code



## **Disclaimer**

ALL PRODUCT, PRODUCT SPECIFICATIONS AND DATA ARE SUBJECT TO CHANGE WITHOUT NOTICE TO IMPROVE RELIABILITY, FUNCTION OR DESIGN OR OTHERWISE.

Vishay Intertechnology, Inc., its affiliates, agents, and employees, and all persons acting on its or their behalf (collectively, "Vishay"), disclaim any and all liability for any errors, inaccuracies or incompleteness contained in any datasheet or in any other disclosure relating to any product.

Vishay makes no warranty, representation or guarantee regarding the suitability of the products for any particular purpose or the continuing production of any product. To the maximum extent permitted by applicable law, Vishay disclaims (i) any and all liability arising out of the application or use of any product, (ii) any and all liability, including without limitation special, consequential or incidental damages, and (iii) any and all implied warranties, including warranties of fitness for particular purpose, non-infringement and merchantability.

Statements regarding the suitability of products for certain types of applications are based on Vishay's knowledge of typical requirements that are often placed on Vishay products in generic applications. Such statements are not binding statements about the suitability of products for a particular application. It is the customer's responsibility to validate that a particular product with the properties described in the product specification is suitable for use in a particular application. Parameters provided in datasheets and / or specifications may vary in different applications and performance may vary over time. All operating parameters, including typical parameters, must be validated for each customer application by the customer's technical experts. Product specifications do not expand or otherwise modify Vishay's terms and conditions of purchase, including but not limited to the warranty expressed therein.

Except as expressly indicated in writing, Vishay products are not designed for use in medical, life-saving, or life-sustaining applications or for any other application in which the failure of the Vishay product could result in personal injury or death. Customers using or selling Vishay products not expressly indicated for use in such applications do so at their own risk. Please contact authorized Vishay personnel to obtain written terms and conditions regarding products designed for such applications.

No license, express or implied, by estoppel or otherwise, to any intellectual property rights is granted by this document or by any conduct of Vishay. Product names and markings noted herein may be trademarks of their respective owners.

## Looking for pricing, stock, or lifecycle information?

Click below to explore more details on WIN SOURCE:

 [View OSOPTC1001AT0 on WIN SOURCE](#)

 [Vishay Information](#)

## Optimize Your Supply Chain with WIN SOURCE Solutions

-  Global Sourcing Solution
-  Obsolete Management
-  Cost Control Management
-  Shortage Management
-  Alternative Solution
-  Excess Inventory Management