



**THE DATASHEET OF
IRS21962SPBF**



IRS21962S

Dual channel high-side drivers with floating input

Features

- Two independent high side output channels
- CMOS Schmitt trigger inputs with pull down resistor
- 5V compatible logic level inputs
- Immune to $-V_s$ spike and tolerant to dV_s/dt and dV_{ss}/dt
- Typical operating frequency 200kHz
- RoHS compliant

Product Summary

V_{OFFSET}	600 V
V_{OUT}	10 V – 20 V
I_{o+} & I_{o-} (typical)	0.5 A
t_{ON} & t_{OFF} (typical)	90 ns

Package Type

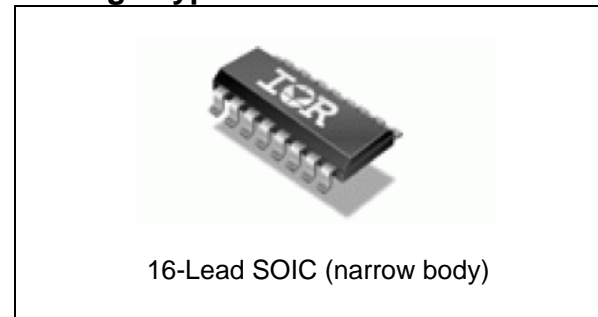

Typical Connection Diagram

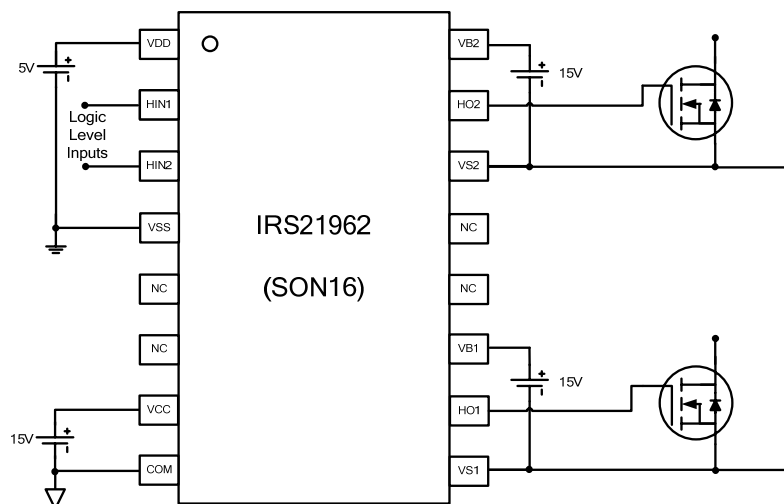

Table of Contents	Page
Description	3
Qualification Information	4
Absolute Maximum Ratings	5
Recommended Operating Conditions	5
Static Electrical Characteristics	6
Dynamic Electrical Characteristics	6
Functional Block Diagram	7
Input/Output Pin Equivalent Circuit Diagram	9
Lead Definitions	10
Lead Assignments	10
Package Details	11
Tape and Reel Details	12
Part Marking Information	13
Ordering Information	14

Description

The IRS21962 is a high voltage, high speed power MOSFET and IGBT driver with propagation delay matched output channels. Proprietary HVIC and latch immune CMOS technologies enable ruggedized monolithic construction. The floating logic input is compatible with standard 5 V CMOS or LSTTL logic and can be operated up to 600 volts above the COM ground. The output driver feature a 500 mA high pulse current buffer stage designed for minimum driver cross-conduction. The floating channel can be used to drive an N-channel power MOSFET or IGBT in the high side configuration, which operates up to 600 V above COM ground.

Qualification Information[†]

Qualification Level		Industrial ^{††}	
		Comments: This family of ICs has passed JEDEC's Industrial qualification. IR's Consumer qualification level is granted by extension of the higher Industrial level.	
Moisture Sensitivity Level		SOIC16N	MSL2 ^{†††} 260°C (per IPC/JEDEC J-STD-020)
ESD	Machine Model	Class B (per JEDEC standard JESD22-A115)	
	Human Body Model	Class 2 (per EIA/JEDEC standard EIA/JESD22-A114)	
IC Latch-Up Test		Class 1, Level A (per JESD78)	
RoHS Compliant		Yes	

† Qualification standards can be found at International Rectifier's web site <http://www.irf.com/>

†† Higher qualification ratings may be available should the user have such requirements. Please contact your International Rectifier sales representative for further information.

††† Higher MSL ratings may be available for the specific package types listed here. Please contact your International Rectifier sales representative for further information.

Absolute Maximum Ratings

Absolute maximum ratings indicate sustained limits beyond which damage to the device may occur. All voltage parameters are absolute voltages referenced to COM, which is the -200V DC bus provided externally.

Symbol	Definition	Min	Max	Units
VCC	Low side supply voltage	-0.3	25	V
VDD	Input logic supply voltage	-0.3	625	V
VSS	Input logic supply return	VDD-25	VDD+0.3	V
HIN1, HIN2	Input logic voltage	VSS-0.3	VDD+0.3	V
VB1, VB2	High side floating well positive supply voltage	-0.3	625	V
VS1	High side floating well negative supply voltage	VB1-25	VB1+0.3	V
VS2	High side floating well negative supply voltage	VB2-25	VB2+0.3	V
HO1	Floating gate drive output voltage	VS1-0.3	VB1+0.3	V
HO2	Floating gate drive output voltage	VS2-0.3	VB2+0.3	V
dVS/dt	Allowable VS1 or VS2 offset supply transient relative to COM	-	50	V/ns
dVSS/dt	Allowable VSS input supply transient relative to COM	-	50	V/ns
P _D	Package Power Dissipation @ T _A ≤+25°C	-	1	W
R _{θJA}	Thermal Resistance, Junction to Ambient	-	100	°C/W
T _J	Junction Temperature	-55	150	°C
T _S	Storage Temperature	-55	150	°C
T _L	Lead temperature (Soldering, 10 seconds)	-	300	°C

Recommended Operating Conditions

For proper operation, the device should be used within the recommended conditions. All voltage parameters are absolute voltages referenced to COM, which is the -200V DC bus provided externally. The offset rating are tested with supplies of (VDD-VSS)=5V and (VCC-COM)=(VB1-VS1)=(VB2-VS2)=15V.

Symbol	Definition	Min	Max	Units
VCC	Low side supply voltage	10	20	V
VDD	Input logic supply voltage	VSS+4.5	VSS+5.5	V
VSS	Input logic supply offset voltage	-0.3	600	V
HIN1, HIN2	IN1~IN2 input voltage	VSS	VDD	V
VB1	High side floating well positive supply voltage	VS1+10	VS1+20	V
VB2	High side floating well positive supply voltage	VS2+10	VS2+20	V
VS1, VS2	High side floating well negative supply voltage	-5	600	V
HO1	Floating gate drive output voltage	VS1	VB1	V
HO2	Floating gate drive output voltage	VS2	VB2	V
T _A	Ambient Temperature	-40	125	°C

Static Electrical Characteristics

(VDD-VSS)=5V and (VCC-COM)=(VBn-VSn)=15V. TA = 25°C. The parameters VIN,th+, VIN,th-, IIN+, IIN-, VDDUV+, and VDDUV- are referenced to VSS. The VBSUV+, VBSUV-, VOH, VOL, IO+, and IO- parameters are referenced to VS1 or VS2. The VCCUV+, VCCUV- parameters are referenced to COM.

Symbol	Definition	Min	Typ	Max	Units	Test Conditions
VDDUV+	VDD supply undervoltage positive going threshold		4.0		V	VSS -COM = 5V
VDDUV-	VDD supply undervoltage negative going threshold		3.9		V	VSS -COM = 5V
VDDUVH	VDD supply undervoltage lockout hysteresis		0.1		V	VSS -COM = 5V
VCCUV+	VCC supply undervoltage positive going threshold	7.5	8.6	9.7	V	
VCCUV-	VCC supply undervoltage negative going threshold	7.1	8.2	9.3	V	
VCCUVH	VCC supply undervoltage lockout hysteresis	---	0.4	---	V	
VBSUV+	VBS supply undervoltage positive going threshold	7.5	8.3	9.4	V	
VBSUV-	VBS supply undervoltage negative going threshold	6.9	7.7	8.8	V	
VBSUVH	VBS supply undervoltage lockout hysteresis	---	0.6	---	V	
ILKDD	Input Logic offset supply leakage current	---	---	50	μA	VDD = VSS = 600V
ILKBS	Highside floating well offset supply leakage current	---	---	50		VB = VS = 600V
IQDD	Quiescent VDD supply current	---	105	180		VIN = 0V or 5V
IQBS	Quiescent VBS supply current	---	100	175	uA	VIN = 0V or 5V
IQCC	Quiescent VCC supply current	---	180	280		VIN = 0V or 5V
VIN,th+	Logic "1" input threshold	3.5			V	
VIN,th-	Logic "0" input threshold			0.6		
VOH	High level output voltage, Vo -VBIAS	---	---	1		Io+=20mA
VOL	Low level output voltage, Vo	---	---	1	V	Io-=20mA
IIN+	Logic "1" input bias current	---	5	---	uA	VIN=5V
IIN-	Logic "0" input bias current	---	0	---		VIN=0V
Io+	Output high short circuit pulsed current	---	500	---	mA	VO=15V, VIN=5V, PW<=10us
Io-	Output low short circuit pulsed current	---	500	---		VO=0V, VIN=0VP, W<=10us

Dynamic Electrical Characteristics

(VDD-VSS)=5V and (VCC-COM)=(VBn-VSn)=15V. TA = 25. °C CL = 1000pF unless otherwise specified.

All parameters are reference to COM.

Symbol	Definition	Min	Typ	Max	Unit	Test Conditions
t _{on} , t _{off}	Propagation delay from input pin HIN to output pin HO	55	90	125	ns	VSS=200V, VS=0V
t _r	Turn-on 10%-to-90% rise time at HO pin		25	70	ns	VSS=200V, VS=0V
t _f	Turn-off 90%-to-10% fall time at HO pin		25	70	ns	VSS=200V, VS=0V

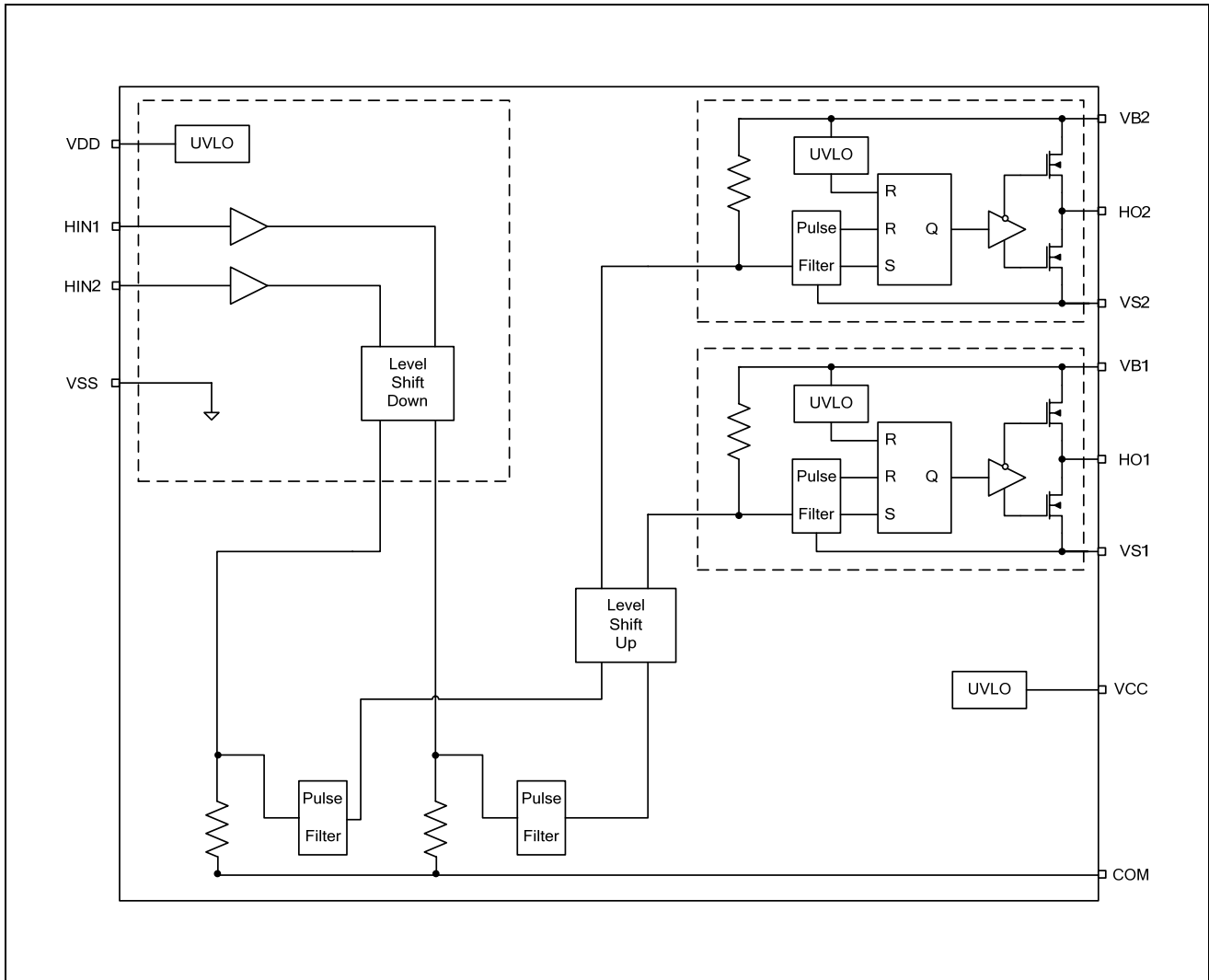

Figure 1 Functional Block Diagram

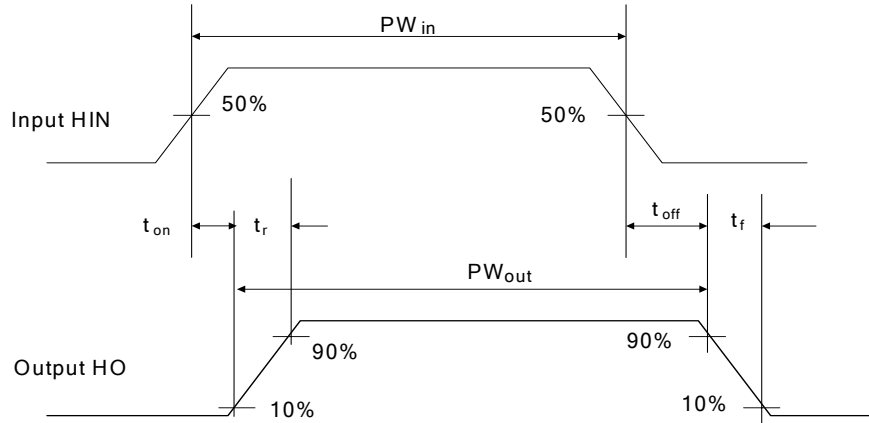

Figure 2 Switching Time Waveforms

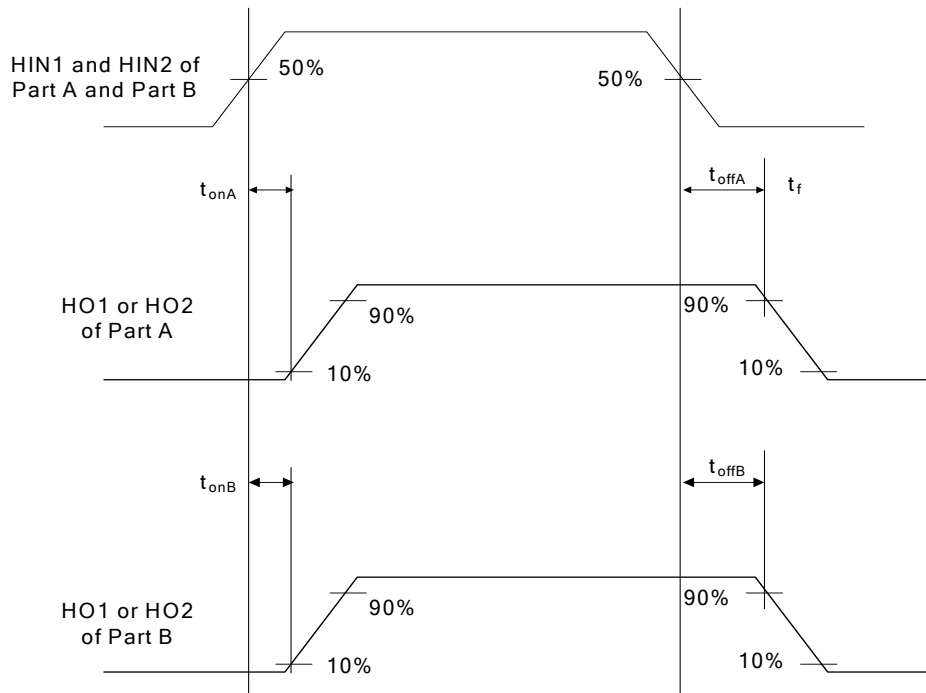
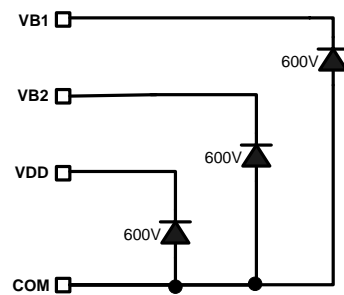
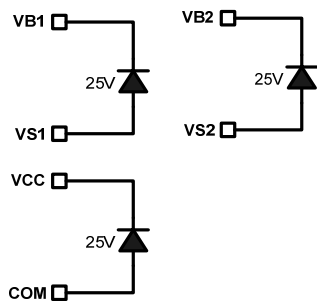
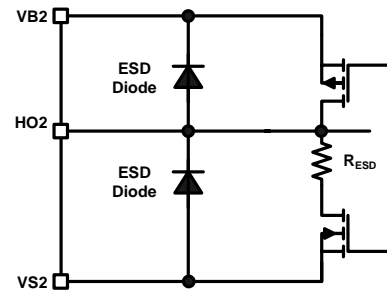
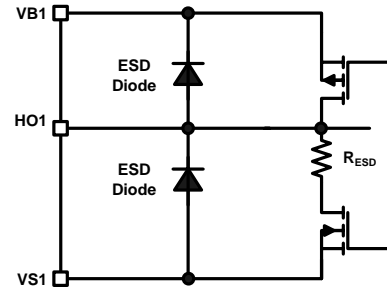
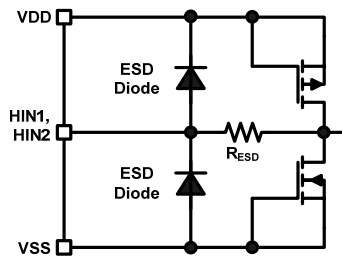

Figure 3 Switching Time Waveforms – Part to Part Propagation Delay Matching

Input/Output Pin Equivalent Circuit Diagrams



Lead Definitions:

Pin	Symbol	Description
1	VDD	Input logic supply voltage
2	HIN1	Logic input channel 1
3	HIN2	Logic input channel 2
4	VSS	Input logic offset voltage
5	NC	No connection
6	NC	No connection
7	VCC	Low side supply voltage
8	COM	Ground
9	VS1	High side floating well offset voltage
10	HO1	Floating gate driver output voltage channel 1
11	VB1	High side floating well positive supply
12	NC	No connection
13	NC	No connection
14	VS2	High side floating well offset voltage
15	HO2	Floating gate driver output voltage channel 2
16	VB2	High side floating well positive supply

Lead Assignments

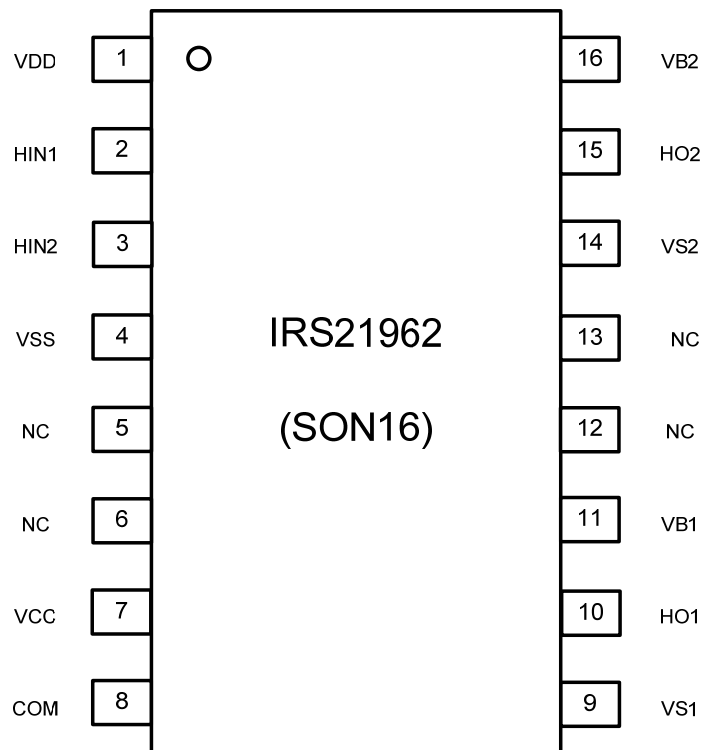

Package Details: SOIC16N

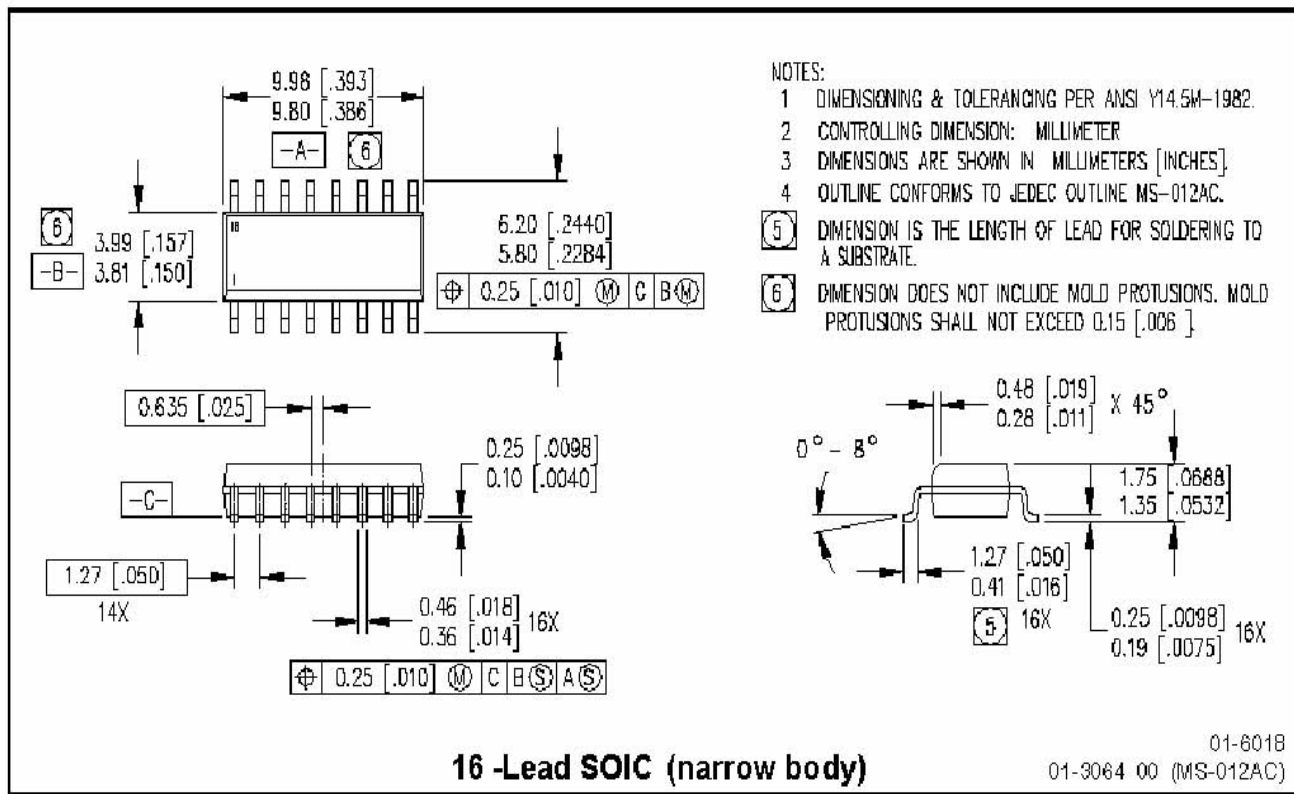

NOTES:

- 1 DIMENSIONING & TOLERANCING PER ANSI Y14.5M-1982.
- 2 CONTROLLING DIMENSION: MILLIMETER
- 3 DIMENSIONS ARE SHOWN IN MILLIMETERS [INCHES].
- 4 OUTLINE CONFORMS TO JEDEC OUTLINE MS-012AC.
- 5 DIMENSION IS THE LENGTH OF LEAD FOR SOLDERING TO A SUBSTRATE.
- 6 DIMENSION DOES NOT INCLUDE MOLD PROTUSIONS. MOLD PROTUSIONS SHALL NOT EXCEED 0.15 [.006]

Tape and Reel Details: SOIC16N

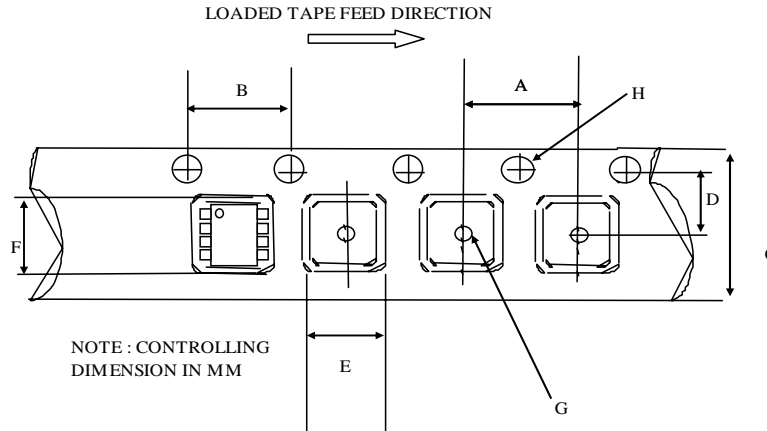

CARRIER TAPE DIMENSION FOR 16SOICN

Code	Metric		Imperial	
	Min	Max	Min	Max
A	7.90	8.10	0.311	0.318
B	3.90	4.10	0.153	0.161
C	15.70	16.30	0.618	0.641
D	7.40	7.60	0.291	0.299
E	6.40	6.60	0.252	0.260
F	10.20	10.40	0.402	0.409
G	1.50	n/a	0.059	n/a
H	1.50	1.60	0.059	0.062

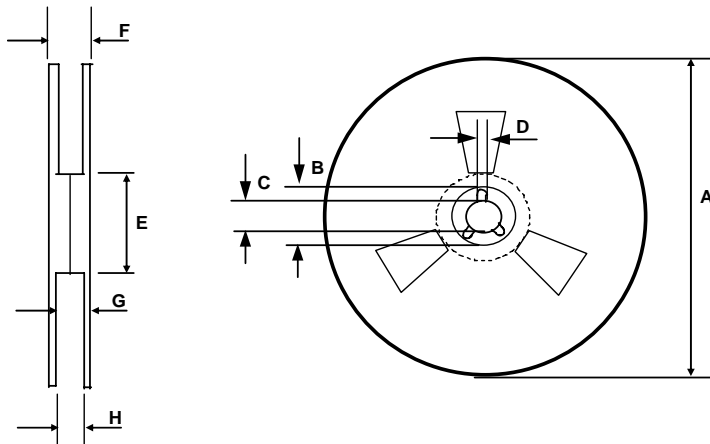

REEL DIMENSIONS FOR 16SOICN

Code	Metric		Imperial	
	Min	Max	Min	Max
A	329.60	330.25	12.976	13.001
B	20.95	21.45	0.824	0.844
C	12.80	13.20	0.503	0.519
D	1.95	2.45	0.767	0.096
E	98.00	102.00	3.858	4.015
F	n/a	22.40	n/a	0.881
G	18.50	21.10	0.728	0.830
H	16.40	18.40	0.645	0.724

Part Marking Information

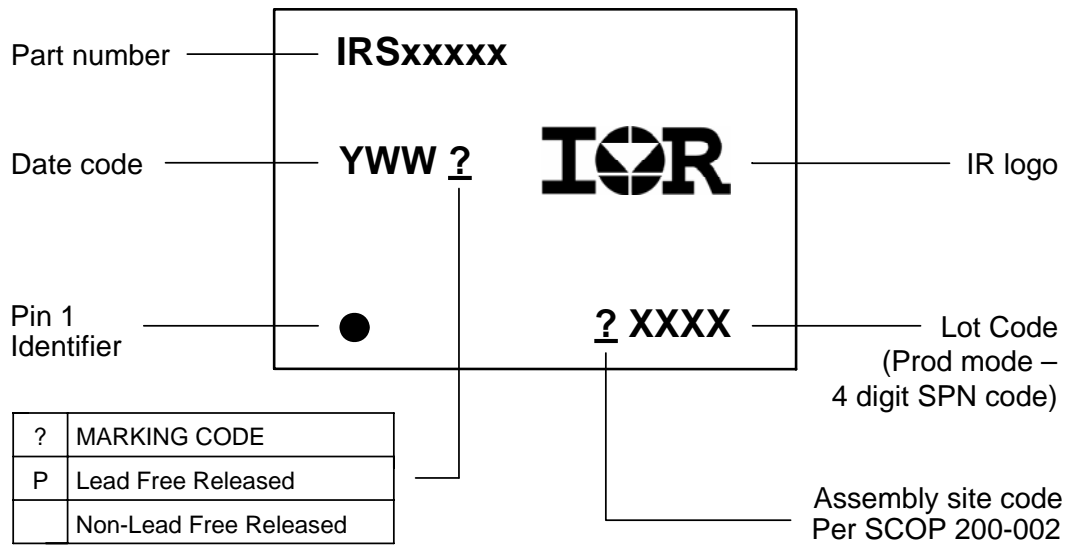

Ordering Information

Base Part Number	Package Type	Standard Pack		Complete Part Number
		Form	Quantity	
IRS21962	SOIC16N	Tube/Bulk	45	IRS21962SPBF
		Tape and Reel	2500	IRS21962STRPBF

The information provided in this document is believed to be accurate and reliable. However, International Rectifier assumes no responsibility for the consequences of the use of this information. International Rectifier assumes no responsibility for any infringement of patents or of other rights of third parties which may result from the use of this information. No license is granted by implication or otherwise under any patent or patent rights of International Rectifier. The specifications mentioned in this document are subject to change without notice. This document supersedes and replaces all information previously supplied.

For technical support, please contact IR's Technical Assistance Center
<http://www.irf.com/technical-info/>

WORLD HEADQUARTERS:
 233 Kansas St., El Segundo, California 90245
 Tel: (310) 252-7105

Looking for pricing, stock, or lifecycle information?

Click below to explore more details on WIN SOURCE:

 [View IRS21962SPBF](#) on WIN SOURCE

 [Infineon Technologies](#) Information

Optimize Your Supply Chain with WIN SOURCE Solutions

-  Global Sourcing Solution
-  Obsolete Management
-  Cost Control Management
-  Shortage Management
-  Alternative Solution
-  Excess Inventory Management