



**THE DATASHEET OF
74VCXH245MNR2G**



74VCXH245

Low-Voltage 1.8/2.5/3.3 V 8-Bit Transceiver

(3-State, Non-Inverting with Bushold)

The 74VCXH245 is an advanced performance, non-inverting 8-bit transceiver. It is designed for very high-speed, very low-power operation in 1.8 V, 2.5 V or 3.3 V systems.

The 74VCXH245 is designed as a byte control. The Transmit/Receive (T/\bar{R}_n) inputs determine the direction of data flow through the bidirectional transceiver. Transmit (active-HIGH) enables data from A ports to B ports; Receive (active-LOW) enables data from B to A ports. The Output Enable input (\overline{OE}), when HIGH, disables both A and B ports by placing them in a HIGH Z condition. The data inputs include active bushold circuitry, eliminating the need for external pullup resistors to hold unused or floating inputs at a valid logic state.

Features

- Designed for Low Voltage Operation: $V_{CC} = 1.65\text{--}3.6\text{ V}$
- High Speed Operation:
 - 3.5 ns max for 3.0 to 3.6 V
 - 4.2 ns max for 2.3 to 2.7 V
 - 8.4 ns max for 1.65 to 1.95 V
- Static Drive:
 - $\pm 24\text{ mA}$ Drive at 3.0 V
 - $\pm 18\text{ mA}$ Drive at 2.3 V
 - $\pm 6\text{ mA}$ Drive at 1.65 V
- Includes Active Bushold to Hold Unused or Floating Data Inputs at a Valid Logic State
- Near Zero Static Supply Current in All Three Logic States (20 μA) Substantially Reduces System Power Requirements
- Latchup Performance Exceeds $\pm 200\text{ mA}$ @ 85°C
- ESD Performance:
 - Human Body Model >2000 V
 - Machine Model >200 V
- Pb-Free Package is Available



ON Semiconductor®

<http://onsemi.com>

MARKING DIAGRAM

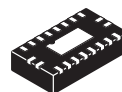

QFN
MNR2 SUFFIX
CASE 485AA

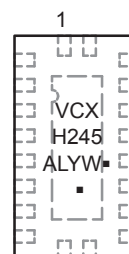

A = Assembly Location
L = Wafer Lot
Y = Year
W = Work Week
▪ = Pb-Free Package
(Note: Microdot may be in either location)

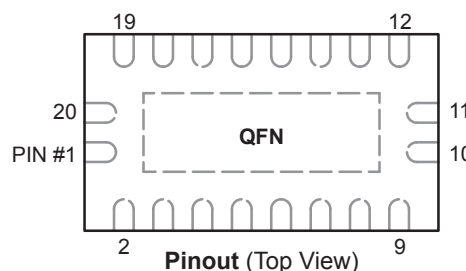

ORDERING INFORMATION

Device	Package	Shipping†
74VCXH245MNR2	QFN	3000/Tape&Reel
74VCXH245MNR2G	QFN (Pb-Free)	3000/Tape&Reel

†For information on tape and reel specifications, including part orientation and tape sizes, please refer to our Tape and Reel Packaging Specifications Brochure, BRD8011/D.

*For additional information on our Pb-Free strategy and soldering details, please download the ON Semiconductor Soldering and Mounting Techniques Reference Manual, SOLDERRM/D.

74VCXH245

PIN NAMES

PINS	FUNCTION
\overline{OE}	Output Enable Input
T/R	Transmit/Receive Input
A0-A7	Side A Bushold Inputs or 3-State Outputs
B0-B7	Side B Bushold Inputs or 3-State Outputs

TRUTH TABLE

INPUTS		OPERATING MODE Non-Inverting
OE	T/R	
L	L	B Data to A Bus
L	H	A Data to B Bus
H	X	Z State

H = High Voltage Level
 L = Low Voltage Level
 Z = High Impedance State
 X = High or Low Voltage Level and Transitions are Acceptable

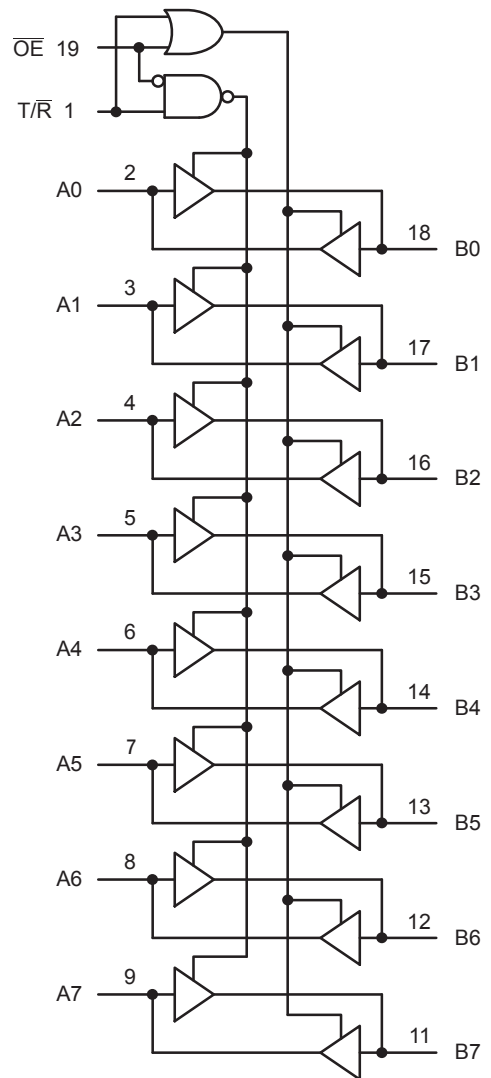

V_{CC} = Pin 20
 GND = Pin 10

Figure 1. Logic Diagram

ABSOLUTE MAXIMUM RATINGS

Symbol	Parameter	Value	Condition	Unit
V_{CC}	DC Supply Voltage	-0.5 to +4.6		V
V_I	DC Input Voltage	$-0.5 \leq V_I \leq V_{CC} + 0.5$		V
V_O	DC Output Voltage	$-0.5 \leq V_O \leq V_{CC} + 0.5$	Note 1	V
I_{IK}	DC Input Diode Current	-50	$V_I < GND$	mA
I_{OK}	DC Output Diode Current	-50	$V_O < GND$	mA
		+50	$V_O > V_{CC}$	mA
I_O	DC Output Source/Sink Current	± 50		mA
I_{CC}	DC Supply Current Per Supply Pin	± 100		mA
I_{GND}	DC Ground Current Per Ground Pin	± 100		mA
T_{STG}	Storage Temperature Range	-65 to +150		$^{\circ}C$

Maximum ratings are those values beyond which device damage can occur. Maximum ratings applied to the device are individual stress limit values (not normal operating conditions) and are not valid simultaneously. If these limits are exceeded, device functional operation is not implied, damage may occur and reliability may be affected.

1. I_O absolute maximum rating must be observed.

74VCXH245

RECOMMENDED OPERATING CONDITIONS (Note 2)

Symbol	Parameter	Min	Typ	Max	Unit
V_{CC}	Supply Voltage	Operating	3.3	3.6	V
		Data Retention Only	1.2	3.3	3.6
V_I	Input Voltage	-0.3		V_{CC}	V
V_O	Output Voltage	0		V_{CC}	V
I_{OH}	HIGH Level Output Current, $V_{CC} = 3.0\text{ V} - 3.6\text{ V}$			-24	mA
I_{OL}	LOW Level Output Current, $V_{CC} = 3.0\text{ V} - 3.6\text{ V}$			24	mA
I_{OH}	HIGH Level Output Current, $V_{CC} = 2.3\text{ V} - 2.7\text{ V}$			-18	mA
I_{OL}	LOW Level Output Current, $V_{CC} = 2.3\text{ V} - 2.7\text{ V}$			18	mA
I_{OH}	HIGH Level Output Current, $V_{CC} = 1.65\text{ V} - 1.95\text{ V}$			-6	mA
I_{OL}	LOW Level Output Current, $V_{CC} = 1.65\text{ V} - 1.95\text{ V}$			6	mA
T_A	Operating Free-Air Temperature	-40		+85	°C
$\Delta t/\Delta V$	Input Transition Rise or Fall Rate, V_{IN} from 0.8 V to 2.0 V, $V_{CC} = 3.0\text{ V}$	0		10	ns/V

2. Floating or unused control inputs must be held HIGH or LOW.

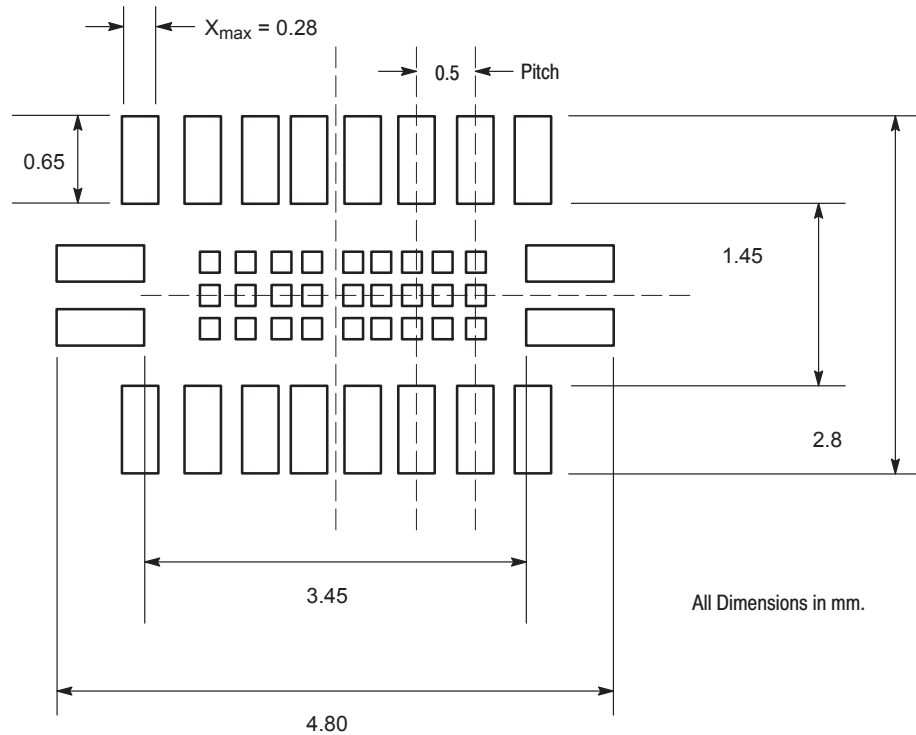

Figure 2. 20 Pad QFN Suggested Board Layout (Bottom View)

74VCXH245

DC ELECTRICAL CHARACTERISTICS

Symbol	Characteristic	Condition	T _A = -40°C to +85°C		Unit
			Min	Max	
V _{IH}	HIGH Level Input Voltage (Note 3)	1.65 V ≤ V _{CC} < 1.95 V	0.65 x V _{CC}		V
		2.3 V ≤ V _{CC} ≤ 2.7 V	1.6		
		2.7 V < V _{CC} ≤ 3.6 V	2.0		
V _{IL}	LOW Level Input Voltage (Note 3)	1.65 V ≤ V _{CC} < 1.95 V		0.35 x V _{CC}	V
		2.3 V ≤ V _{CC} ≤ 2.7 V		0.7	
		2.7 V < V _{CC} ≤ 3.6 V		0.8	
V _{OH}	HIGH Level Output Voltage	1.65 V ≤ V _{CC} ≤ 3.6 V; I _{OH} = -100 μA	V _{CC} - 0.2		V
		V _{CC} = 1.65 V; I _{OH} = -6 mA	1.25		
		V _{CC} = 2.3 V; I _{OH} = -6 mA	2.0		
		V _{CC} = 2.3 V; I _{OH} = -12 mA	1.8		
		V _{CC} = 2.3 V; I _{OH} = -18 mA	1.7		
		V _{CC} = 2.7 V; I _{OH} = -12 mA	2.2		
		V _{CC} = 3.0 V; I _{OH} = -18 mA	2.4		
V _{OL}	LOW Level Output Voltage	1.65 V ≤ V _{CC} ≤ 3.6 V; I _{OL} = 100 μA		0.2	V
		V _{CC} = 1.65 V; I _{OL} = 6 mA		0.3	
		V _{CC} = 2.3 V; I _{OL} = 12 mA		0.4	
		V _{CC} = 2.3 V; I _{OL} = 18 mA		0.6	
		V _{CC} = 2.7 V; I _{OL} = 12 mA		0.4	
		V _{CC} = 3.0 V; I _{OL} = 18 mA		0.4	
		V _{CC} = 3.0 V; I _{OL} = 24 mA		0.55	
I _I	Input Leakage Current	V _{IN} = V _{CC} or GND; V _{CC} = 3.6 V		±5.0	μA
I _{I(HOLD)}	Minimum Bushold Input Current	V _{CC} = 3.0 V, V _{IN} = 0.8 V	75		μA
		V _{CC} = 3.0 V, V _{IN} = 2.0 V	-75		
		V _{CC} = 2.3 V, V _{IN} = 0.7 V	45		
		V _{CC} = 2.3 V, V _{IN} = 1.6 V	-45		
		V _{CC} = 1.65 V, V _{IN} = 0.57 V	25		
		V _{CC} = 1.65 V, V _{IN} = 1.07 V	-25		
I _{I(OD)}	Minimum Bushold Over-Drive Current Needed to Change State	V _{CC} = 3.6 V, (Note 4)	450		μA
		V _{CC} = 3.6 V, (Note 5)	-450		
		V _{CC} = 2.7 V, (Note 4)	300		
		V _{CC} = 2.7 V, (Note 5)	-300		
		V _{CC} = 1.95 V, (Note 4)	200		
		V _{CC} = 1.95 V, (Note 5)	-200		
I _{OZ}	3-State Output Current	V _O = V _{CC} or GND; V _{CC} = 3.6 V; V _I = V _{IH} or V _{IL}		±10	μA
I _{CC}	Quiescent Supply Current (Note 6)	1.65 V ≤ V _{CC} ≤ 3.6 V; V _I = GND or V _{CC}		20	μA
ΔI _{CC}	Increase in I _{CC} per Input	2.7 V < V _{CC} ≤ 3.6 V; V _{IH} = V _{CC} - 0.6 V		750	μA

3. These values of V_I are used to test DC electrical characteristics only.

4. An external driver must source at least the specified current to switch from LOW-to-HIGH.

5. An external driver must sink at least the specified current to switch from HIGH-to-LOW.

6. Outputs disabled or 3-state only.

74VCXH245

AC CHARACTERISTICS (Note 7; $t_R = t_F = 2.0$ ns; $C_L = 30$ pF; $R_L = 500 \Omega$)

Symbol	Parameter	Waveform	Limits						Unit
			$T_A = -40^\circ\text{C to } +85^\circ\text{C}$						
			$V_{CC} = 3.0$ V to 3.6 V		$V_{CC} = 2.3$ V to 2.7 V		$V_{CC} = 1.65$ V to 1.95 V		
			Min	Max	Min	Max	Min	Max	
t_{PLH} t_{PHL}	Propagation Delay Input to Output	1	0.6 0.6	3.5 3.5	0.8 0.8	4.2 4.2	1.5 1.5	8.4 8.4	ns
t_{PZH} t_{PZL}	Output Enable Time to High and Low Level	2	0.6 0.6	4.5 4.5	0.8 0.8	5.6 5.6	1.5 1.5	9.8 9.8	ns
t_{PHZ} t_{PLZ}	Output Disable Time From High and Low Level	2	0.6 0.6	3.6 3.6	0.8 0.8	4.0 4.0	1.5 1.5	7.2 7.2	ns
t_{OSHL} t_{OSLH}	Output-to-Output Skew (Note 8)			0.5 0.5		0.5 0.5		0.75 0.75	ns

7. For $C_L = 50$ pF, add approximately 300 ps to the AC maximum specification.

8. Skew is defined as the absolute value of the difference between the actual propagation delay for any two separate outputs of the same device. The specification applies to any outputs switching in the same direction, either HIGH-to-LOW (t_{OSHL}) or LOW-to-HIGH (t_{OSLH}); parameter guaranteed by design.

DYNAMIC SWITCHING CHARACTERISTICS

Symbol	Characteristic	Condition	$T_A = +25^\circ\text{C}$	Unit
			Typ	
V_{OLP}	Dynamic LOW Peak Voltage (Note 9)	$V_{CC} = 1.8$ V, $C_L = 30$ pF, $V_{IH} = V_{CC}$, $V_{IL} = 0$ V	0.3	V
		$V_{CC} = 2.5$ V, $C_L = 30$ pF, $V_{IH} = V_{CC}$, $V_{IL} = 0$ V	0.7	
		$V_{CC} = 3.3$ V, $C_L = 30$ pF, $V_{IH} = V_{CC}$, $V_{IL} = 0$ V	1.0	
V_{OLV}	Dynamic LOW Valley Voltage (Note 9)	$V_{CC} = 1.8$ V, $C_L = 30$ pF, $V_{IH} = V_{CC}$, $V_{IL} = 0$ V	-0.3	V
		$V_{CC} = 2.5$ V, $C_L = 30$ pF, $V_{IH} = V_{CC}$, $V_{IL} = 0$ V	-0.7	
		$V_{CC} = 3.3$ V, $C_L = 30$ pF, $V_{IH} = V_{CC}$, $V_{IL} = 0$ V	-1.0	
V_{OHV}	Dynamic HIGH Valley Voltage (Note 10)	$V_{CC} = 1.8$ V, $C_L = 30$ pF, $V_{IH} = V_{CC}$, $V_{IL} = 0$ V	1.3	V
		$V_{CC} = 2.5$ V, $C_L = 30$ pF, $V_{IH} = V_{CC}$, $V_{IL} = 0$ V	1.7	
		$V_{CC} = 3.3$ V, $C_L = 30$ pF, $V_{IH} = V_{CC}$, $V_{IL} = 0$ V	2.0	

9. Number of outputs defined as "n". Measured with "n-1" outputs switching from HIGH-to-LOW or LOW-to-HIGH. The remaining output is measured in the LOW state.

10. Number of outputs defined as "n". Measured with "n-1" outputs switching from HIGH-to-LOW or LOW-to-HIGH. The remaining output is measured in the HIGH state.

CAPACITIVE CHARACTERISTICS

Symbol	Parameter	Condition	Typical	Unit
C_{IN}	Input Capacitance	Note 11	6	pF
C_{OUT}	Output Capacitance	Note 11	7	pF
C_{PD}	Power Dissipation Capacitance	Note 11, 10 MHz	20	pF

11. $V_{CC} = 1.8, 2.5$ or 3.3 V; $V_I = 0$ V or V_{CC} .

74VCXH245

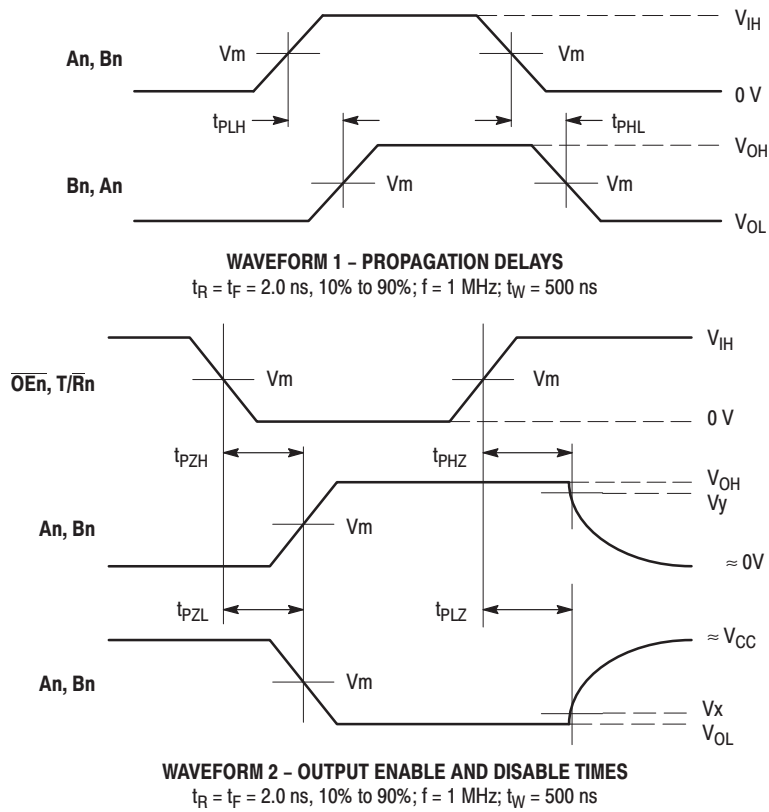
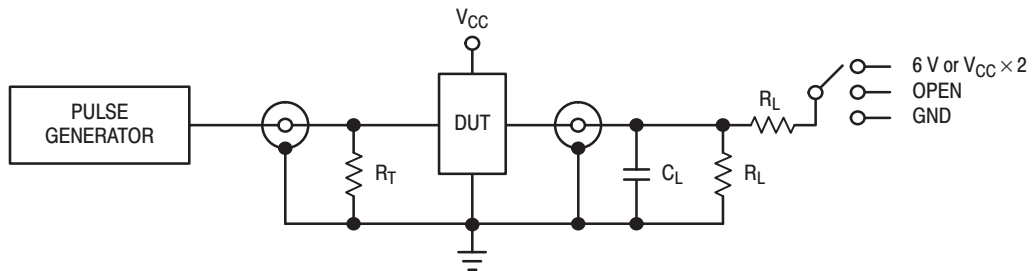

Figure 3. AC Waveforms

Symbol	V_{CC}		
	3.3 V \pm 0.3 V	2.5 V \pm 0.2 V	1.8 V \pm 0.15 V
V_{IH}	2.7 V	V_{CC}	V_{CC}
V_m	1.5 V	$V_{CC}/2$	$V_{CC}/2$
V_x	$V_{OL} + 0.3 \text{ V}$	$V_{OL} + 0.15 \text{ V}$	$V_{OL} + 0.15 \text{ V}$
V_y	$V_{OH} - 0.3 \text{ V}$	$V_{OH} - 0.15 \text{ V}$	$V_{OH} - 0.15 \text{ V}$



TEST	SWITCH
t_{PLH} , t_{PHL}	Open
t_{PZL} , t_{PLZ}	6 V at $V_{CC} = 3.3 \pm 0.3 \text{ V}$; $V_{CC} \times 2$ at $V_{CC} = 2.5 \pm 0.2 \text{ V}$; 1.8 V \pm 0.15 V
t_{PZH} , t_{PHZ}	GND

$C_L = 30 \text{ pF}$ or equivalent (Includes jig and probe capacitance)
 $R_L = 500 \text{ } \Omega$ or equivalent
 $R_T = Z_{OUT}$ of pulse generator (typically 50 Ω)

Figure 4. Test Circuit

74VCXH245

PACKAGE DIMENSIONS

QFN
MNR2 SUFFIX
CASE 485AA-01
ISSUE A

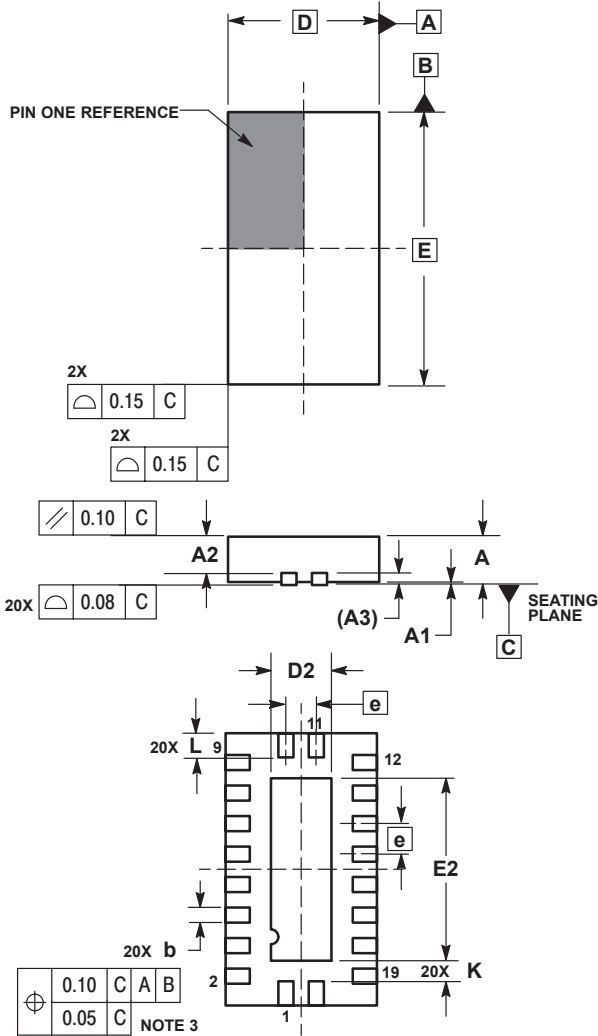

NOTES:

1. DIMENSIONING AND TOLERANCING PER ASME Y14.5M, 1994.
2. CONTROLLING DIMENSION: MILLIMETERS.
3. DIMENSIONS b APPLIES TO PLATED TERMINAL AND IS MEASURED BETWEEN 0.25 AND 0.30 MM FROM TERMINAL.
4. COPLANARITY APPLIES TO THE EXPOSED PAD AS WELL AS THE TERMINALS.

DIM	MILLIMETERS	
	MIN	MAX
A	0.80	1.00
A1	0.00	0.05
A2	0.65	0.75
A3	0.20 REF	
b	0.20	0.30
D	2.50 BSC	
D2	0.85	1.15
E	4.50 BSC	
E2	2.85	3.15
e	0.50 BSC	
K	0.20	---
L	0.35	0.45

ON Semiconductor and  are registered trademarks of Semiconductor Components Industries, LLC (SCILLC). SCILLC reserves the right to make changes without further notice to any products herein. SCILLC makes no warranty, representation or guarantee regarding the suitability of its products for any particular purpose, nor does SCILLC assume any liability arising out of the application or use of any product or circuit, and specifically disclaims any and all liability, including without limitation special, consequential or incidental damages. "Typical" parameters which may be provided in SCILLC data sheets and/or specifications can and do vary in different applications and actual performance may vary over time. All operating parameters, including "Typicals" must be validated for each customer application by customer's technical experts. SCILLC does not convey any license under its patent rights nor the rights of others. SCILLC products are not designed, intended, or authorized for use as components in systems intended for surgical implant into the body, or other applications intended to support or sustain life, or for any other application in which the failure of the SCILLC product could create a situation where personal injury or death may occur. Should Buyer purchase or use SCILLC products for any such unintended or unauthorized application, Buyer shall indemnify and hold SCILLC and its officers, employees, subsidiaries, affiliates, and distributors harmless against all claims, costs, damages, and expenses, and reasonable attorney fees arising out of, directly or indirectly, any claim of personal injury or death associated with such unintended or unauthorized use, even if such claim alleges that SCILLC was negligent regarding the design or manufacture of the part. SCILLC is an Equal Opportunity/Affirmative Action Employer. This literature is subject to all applicable copyright laws and is not for resale in any manner.

PUBLICATION ORDERING INFORMATION

LITERATURE FULFILLMENT:

Literature Distribution Center for ON Semiconductor
P.O. Box 61312, Phoenix, Arizona 85082-1312 USA

Phone: 480-829-7710 or 800-344-3860 Toll Free USA/Canada

Fax: 480-829-7709 or 800-344-3867 Toll Free USA/Canada

Email: orderlit@onsemi.com

N. American Technical Support: 800-282-9855 Toll Free
USA/Canada

Japan: ON Semiconductor, Japan Customer Focus Center
2-9-1 Kamimeguro, Meguro-ku, Tokyo, Japan 153-0051
Phone: 81-3-5773-3850

ON Semiconductor Website: <http://onsemi.com>

Order Literature: <http://www.onsemi.com/litorder>

For additional information, please contact your
local Sales Representative.

Looking for pricing, stock, or lifecycle information?

Click below to explore more details on WIN SOURCE:

 [View 74VCXH245MNR2G on WIN SOURCE](#)

 [ON Semiconductor](#) Information

Optimize Your Supply Chain with WIN SOURCE Solutions

-  Global Sourcing Solution
-  Obsolete Management
-  Cost Control Management
-  Shortage Management
-  Alternative Solution
-  Excess Inventory Management