



SANYO Semiconductors

DATA SHEET

An ON Semiconductor Company

LV8018W Bi-CMOS IC For Portable MD 4ch PWM H-bridge Driver

Overview

The LV8018W is 4-channel PWM-drive H-bridge driver for portable MD.

Functions

- 4-channel PWM-drive H-bridge driver.
- Built-in charge pump circuit.
- Built-in thermal shutdown circuit.

Specifications

Absolute Maximum Ratings at Ta = 25°C

Parameter	Symbol	Conditions	Ratings	Unit
Supply voltage (Output block)	VBAT max		7	V
Supply voltage (Control block)	V _{CC} max		7	V
Predrive voltage (gate voltage)	VG max		9.5	V
Maximum output current (ch1-ch4)	I _O max		500	mA
Allowable power dissipation	Pd max	Independent IC	0.5	W
Operating temperature	T _{opr}		-20 to +85	°C
Storage temperature	T _{stg}		-55 to +150	°C

Operating Ratings at Ta = 25°C

Parameter	Symbol	Conditions	Ratings	Unit
Recommended supply voltage (Output block)	VBAT max		7	V
Recommended supply voltage (Control block)	V _{CC} max		7	V
Predrive voltage (gate voltage)	VG max		9.5	V

■ Any and all SANYO Semiconductor Co.,Ltd. products described or contained herein are, with regard to "standard application", intended for the use as general electronics equipment (home appliances, AV equipment, communication device, office equipment, industrial equipment etc.). The products mentioned herein shall not be intended for use for any "special application" (medical equipment whose purpose is to sustain life, aerospace instrument, nuclear control device, burning appliances, transportation machine, traffic signal system, safety equipment etc.) that shall require extremely high level of reliability and can directly threaten human lives in case of failure or malfunction of the product or may cause harm to human bodies, nor shall they grant any guarantee thereof. If you should intend to use our products for applications outside the standard applications of our customer who is considering such use and/or outside the scope of our intended standard applications, please consult with us prior to the intended use. If there is no consultation or inquiry before the intended use, our customer shall be solely responsible for the use.

■ Specifications of any and all SANYO Semiconductor Co.,Ltd. products described or contained herein stipulate the performance, characteristics, and functions of the described products in the independent state, and are not guarantees of the performance, characteristics, and functions of the described products as mounted in the customer's products or equipment. To verify symptoms and states that cannot be evaluated in an independent device, the customer should always evaluate and test devices mounted in the customer's products or equipment.

SANYO Semiconductor Co., Ltd.

<http://semicon.sanyo.com/en/network>

LV8018W

Electrical Characteristics at Ta = 25°C, VCC1, 2 = 3.0V, VBAT = 3.0V

Parameter	Symbol	Conditions	Ratings			Unit
			min	typ	max	
Standby current dissipation	I _{CCO}				10	μA
Current dissipation	I _{CC} (A)	V _G OFF = "L"		1.4	1.9	mA
	I _{CC} (B)	V _G OFF = "H"		1.0	1.5	mA
Pre-drive block current dissipation	I _{GO}	V _G = 7V, each logic input = "L"		70	105	μA
	I _G	V _G = 7, input frequency 88kHz		1.0	1.5	mA
S/S bias current	I _{SS}	S/S = 3.0V		80	120	μA
S/S input "High" voltage	V _{SSH}		V _{CC2} -0.6		V _{CC1}	V
S/S input "Low" voltage	V _{SSL}		0		0.6	V
VBATT/2 set voltage accuracy	ΔV _{MON}				±10	%
VBATT/2 limit voltage	V _{MONLIM}		V _{CC1} -0.2	V _{CC1}		V
VBATT monitor input resistance	R _{MON}		35	50	75	kΩ
Logic input bias current	I _{LG}				±1	μA
Logic input "High" voltage	V _{LGH}		V _{CC2} -0.6		V _{CC2}	V
Logic input "Low" voltage	V _{LGL}		0		0.6	V
Booster circuit						
Output voltage	V _{GO}	No load	8.5	8.8		V
	V _G	I _G OUT = -1mA	6.7	7.2		V
Output oscillation-frequency	F _{OSC}		100	115	130	kHz
Clamp voltage	V _{GLIM}	V _G OFF = "L", V _{CC1, 2} = 3.6V	9.2	9.5	9.8	V
MOS driver output stage (V_G = 7V)						
Output ON resistance	R _{on1, 2, 3, 4}	I _O = 100mA, sum of upper and lower outputs		1.3	2.0	Ω
Output propagation delay time	TRISE	*		0.2	1.0	μs
	YFALL	*		0.1	0.7	μs
Minimum pulse width	T _{min}	Output pulse width ≥ (2/3) T _{min} *	200			ns
TSD circuit						
Operating temperature	TSD	*	150	180		°C
Hysteresis width	ΔTSD	*		30		°C

* : "Design" indicates the design target, not the measured value.

Package Dimensions

unit : mm (typ)

3163B

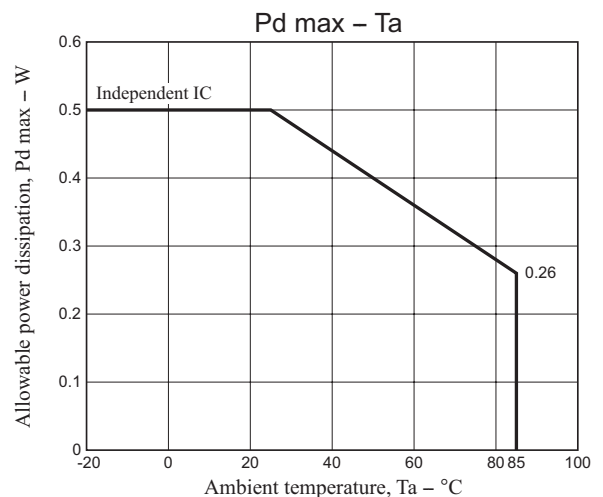
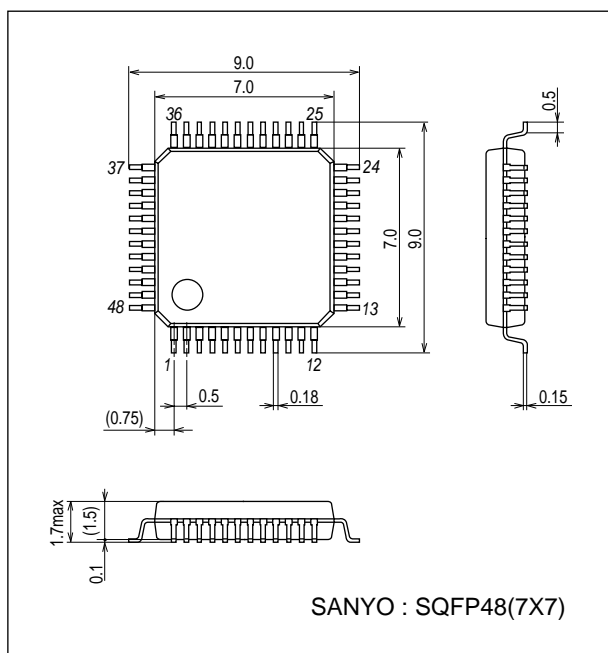

LV8018W

Pin Assignment

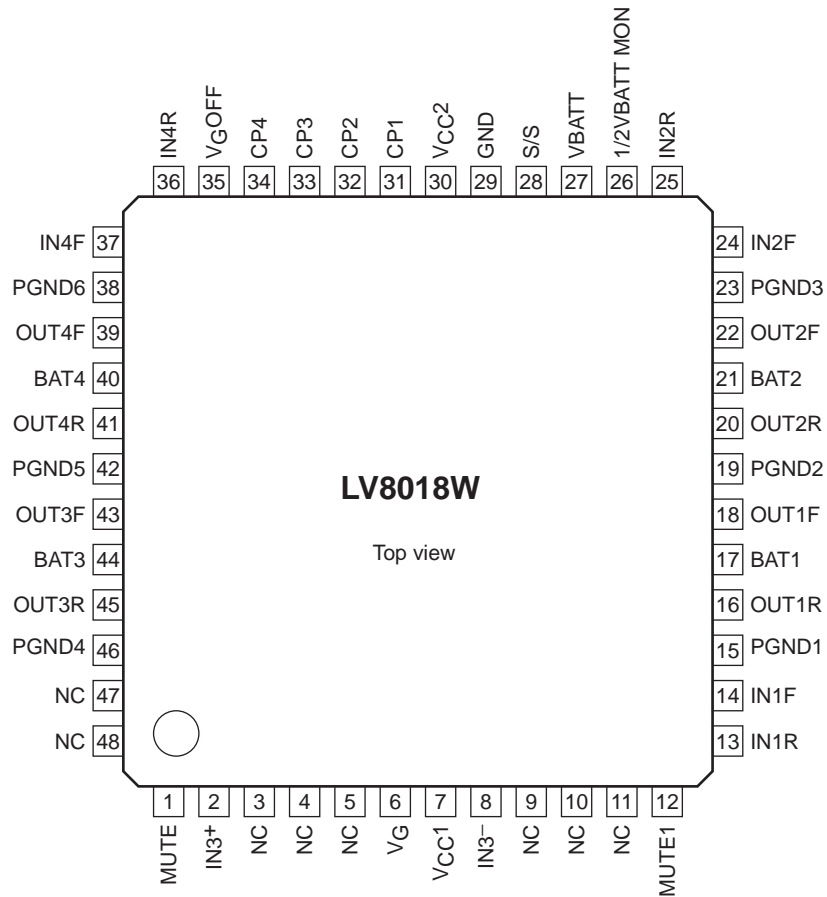

Truth table

Ch1, 2, 4 (for focus, tracking, and traverse)

S/S	MUTE1	IN1, 2, 4F	IN1, 2, 4R	OUT1, 2, 4F	OUT1, 2, 4R
H	H	L	L	L	L
H	H	H	L	H	L
H	H	L	H	L	H
H	H	H	H	L	L
H	L	x	x	Z	Z
L	x	x	x	Z	Z

x : Don't Care, Z : Open

Ch3 (for spindle)

S/S	MUTE	IN3+	IN3-	OUT3F	OUT3R
H	H	L	L	L	L
H	H	H	L	H	L
H	H	L	H	L	L
H	H	H	H	L	H
H	L	x	x	Z	Z
L	x	x	x	Z	Z

x : Don't Care, Z : Open

Block Diagram

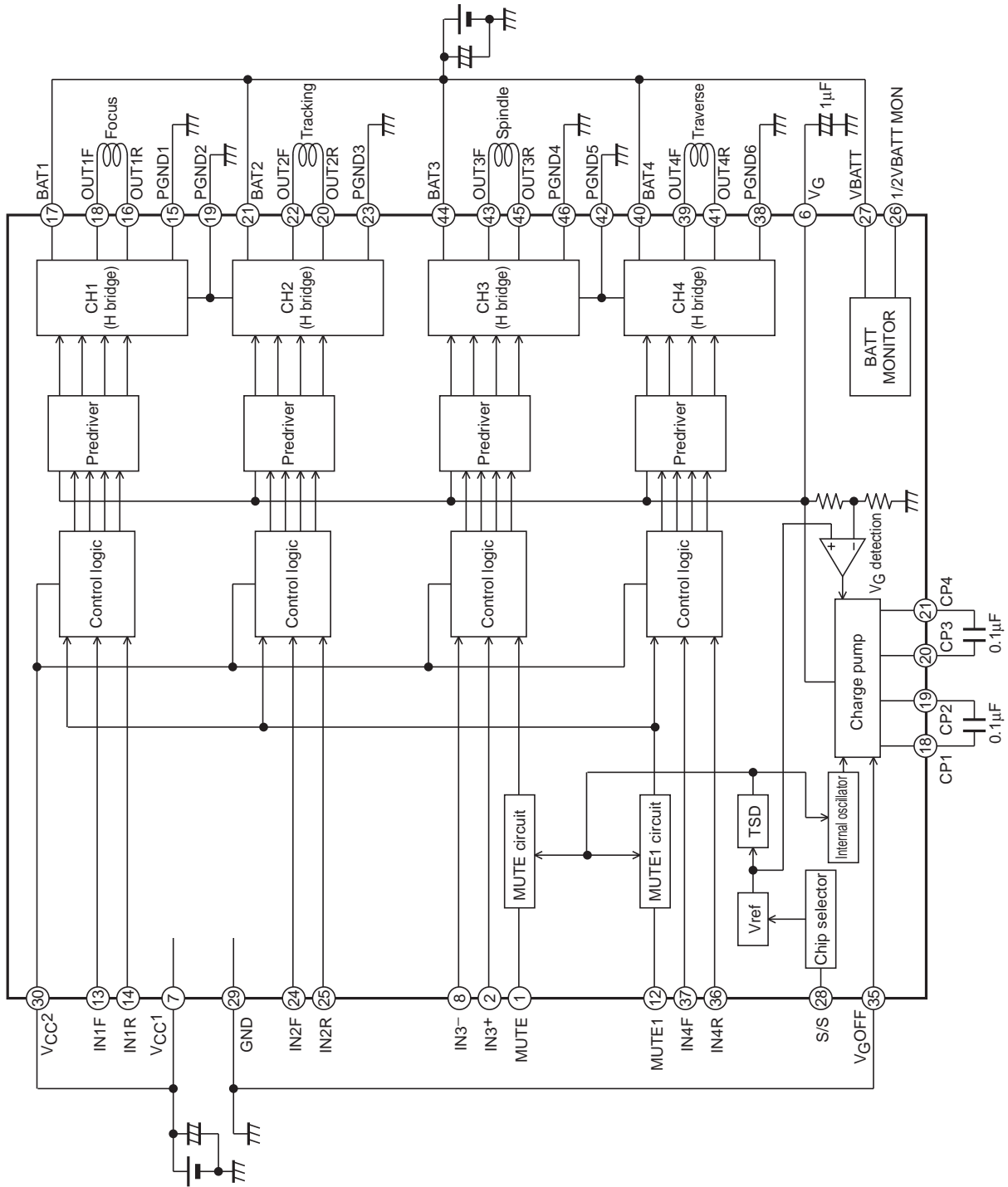

* Constants of external parts are for reference and not guaranteed

LV8018W

Pin Functions

Pin No.	Pin name	Function	Equivalent Circuit
1	MUTE	Channel 3 MUTE pin. L for MUTE ON.	
2 8	IN3+ IN3-	Input pins, each on the forward side and reverse side of Channel 3. (Digital input)	
6	V _G	Pin to provide the supply voltage to the predrive. With V _G OFF = "L", the output voltage of booster circuit is output to this pin. This voltage acts directly as the supply voltage of predrive.	
7	V _{CC1}	Pin to provide the supply voltage of analog signal system.	
12	MUTE1	MUTE pin common to Channel 1, 2, and 4. L for MUTE ON.	
14 13	IN1F IN1R	Input pins, each on the forward side and reverse sides of Channel 1. (Digital input)	
18 16 17 15 19	OUT1F OUT1R BAT1 PGND1 PGND2	OUT1F : Channel 1 forward side output pin. OUT1R : Channel 1 reverse side output pin. BAT1 : Channel 1 output power pin. PGND1, 2 : Power GND pin.	
22 20 21 23	OUT2F OUT2R BAT2 PGND3	OUT2F : Channel 2 forward side output pin. OUT2R : Channel 2 reverse side output pin. BAT2 : Channel 2 output power pin. PGND3 : Power GND pin.	
24 25	IN2F IN2R	Input pins, each on the forward side and reverse side of Channel 2. (Digital input)	

Continued on next page.

LV8018W

Continued from preceding page.

Pin No.	Pin name	Function	Equivalent Circuit
27 26	VBATT 1/2VBATT MON	Output power connection pin Pin to monitor 1/2 of output power supply. Used to monitor the output power supply at the digital servo and to correct the voltage dependence of servo.	
28	S/S	Start/stop pin. H for start and L for stop.	
29	GND	Signal GND pin.	
30	V _{CC2}	Pin to provide supply voltage of the logic signal system.	
31 32 33 34	CP1 CP2 CP3 CP4	CP1, 3 : Switching pins of booster circuit CP2, 4 : Pins to which the rectifier transistor of booster circuit is connected	
35	V _G OFF	Booster circuit ON/OFF selector pin. L for booster circuit ON H for booster circuit OFF	
37 36	IN4F IN4R	Input pins, each on the forward side and reverse side of Channel 4.	
39 41 40 42 38	OUT4F OUT4R BAT4 PGND5 PGND6	OUT4F : Channel 4 forward side output pin. OUT4R : Channel 4 reverse side output pin. BAT4 : Channel 4 output power pin. PGND5, 6 : Power GND pin.	
43 45 44 46	OUT3F OUT3R BAT3 PGND4	OUT3F : Channel 3 forward side output pin. OUT3R : Channel 3 reverse side output pin. BAT3 : Channel 3 output power pin. PGND4 : Power GND pin.	

Cautions for use



1. Apply power in the order from V_{CC} to each BAT. When the external power supply is used for V_G , apply power in the order from V_{CC} , through V_G , to each BAT. For each BAT, turn ON power supply after complete rising of V_{CC} and V_G voltages.
2. Each power supply must be stabilized by inserting a capacitor to GND to prevent entry of ripple and noise. In particular, the capacitor of sufficient capacitance must be used for the output because the large current flows here. The capacitor to be inserted in each power supply should be installed as near as possible to the IC pin.

- SANYO Semiconductor Co.,Ltd. assumes no responsibility for equipment failures that result from using products at values that exceed, even momentarily, rated values (such as maximum ratings, operating condition ranges, or other parameters) listed in products specifications of any and all SANYO Semiconductor Co.,Ltd. products described or contained herein.
- SANYO Semiconductor Co.,Ltd. strives to supply high-quality high-reliability products, however, any and all semiconductor products fail or malfunction with some probability. It is possible that these probabilistic failures or malfunction could give rise to accidents or events that could endanger human lives, trouble that could give rise to smoke or fire, or accidents that could cause damage to other property. When designing equipment, adopt safety measures so that these kinds of accidents or events cannot occur. Such measures include but are not limited to protective circuits and error prevention circuits for safe design, redundant design, and structural design.
- In the event that any or all SANYO Semiconductor Co.,Ltd. products described or contained herein are controlled under any of applicable local export control laws and regulations, such products may require the export license from the authorities concerned in accordance with the above law.
- No part of this publication may be reproduced or transmitted in any form or by any means, electronic or mechanical, including photocopying and recording, or any information storage or retrieval system, or otherwise, without the prior written consent of SANYO Semiconductor Co.,Ltd.
- Any and all information described or contained herein are subject to change without notice due to product/technology improvement, etc. When designing equipment, refer to the "Delivery Specification" for the SANYO Semiconductor Co.,Ltd. product that you intend to use.
- Information (including circuit diagrams and circuit parameters) herein is for example only; it is not guaranteed for volume production.
- Upon using the technical information or products described herein, neither warranty nor license shall be granted with regard to intellectual property rights or any other rights of SANYO Semiconductor Co.,Ltd. or any third party. SANYO Semiconductor Co.,Ltd. shall not be liable for any claim or suits with regard to a third party's intellectual property rights which has resulted from the use of the technical information and products mentioned above.

This catalog provides information as of November, 2008. Specifications and information herein are subject to change without notice.

Looking for pricing, stock, or lifecycle information?

Click below to explore more details on WIN SOURCE:

-  [View LV8018W-MPB-E on WIN SOURCE](#)
-  [ON Semiconductor](#) Information

Optimize Your Supply Chain with WIN SOURCE Solutions

-  Global Sourcing Solution
-  Obsolete Management
-  Cost Control Management
-  Shortage Management
-  Alternative Solution
-  Excess Inventory Management