



**THE DATASHEET OF
VND5E025MK-E**





VND5E025MK-E

Double-channel high-side driver with analog current sense for automotive applications

Features

Max transient supply voltage	V_{CC}	41 V
Operating voltage range	V_{CC}	4.5 to 28 V
Max on-state resistance (per ch.)	R_{ON}	25 m Ω
Current limitation (typ)	I_{LIMH}	60 A
Off-state supply current	I_S	2 μ A ⁽¹⁾

1. Typical value with all loads connected.

- General
 - Inrush current active management by power limitation
 - Very low standby current
 - 3.0V CMOS compatible inputs
 - Optimized electromagnetic emissions
 - Very low electromagnetic susceptibility
 - In compliance with the 2002/95/EC european directive
 - Very low current sense leakage
- Diagnostic functions
 - Proportional load current sense
 - High current sense precision for wide currents range
 - Current sense disable
 - Overload and short to ground (power limitation) indication
 - Thermal shutdown indication
- Protections
 - Undervoltage shutdown
 - Overvoltage clamp
 - Load current limitation
 - Self limiting of fast thermal transients
 - Protection against loss of ground and loss of V_{CC}
 - Overtemperature shutdown with auto restart (thermal shutdown)



- Reverse battery protected (see [Figure 29: Application schematic^{\(1\)}](#))
- Electrostatic discharge protection

Applications

- All types of resistive, inductive and capacitive loads
- Suitable as LED driver

Description

The VND5E025MK-E is a double-channel high-side drivers manufactured in the ST proprietary VIPower™ M0-5 technology and housed in the tiny PowerSSO-24 package.

The VND5E025MK-E is designed to drive 12V automotive grounded loads delivering protection, diagnostics and easy 3V and 5V CMOS compatible interface with any microcontroller.

The device integrates advanced protective functions such as load current limitation, inrush and overload active management by power limitation, overtemperature shut-off with auto-restart and overvoltage active clamp.

A dedicated analog current sense pin is associated with every output channel in order to provide *Enhanced* diagnostic functions including fast detection of overload and short-circuit to ground through power limitation indication and overtemperature indication.

The current sensing and diagnostic feedback of the whole device can be disabled by pulling the CS_DIS pin high to allow sharing of the external sense resistor with other similar devices.

Contents

1	Block diagram and pin description	5
2	Electrical specification	7
2.1	Absolute maximum ratings	7
2.2	Thermal data	8
2.3	Electrical characteristics	9
2.4	Waveforms	18
2.5	Electrical characteristics curves	20
3	Application information	23
3.1	GND protection network against reverse battery	23
3.1.1	Solution 1: resistor in the ground line (RGND only)	23
3.1.2	Solution 2: diode (DGND) in the ground line	24
3.2	Load dump protection	24
3.3	MCU I/Os protection	24
3.4	Current sense and diagnostic	25
3.5	Maximum demagnetization energy (VCC = 13.5V)	26
4	Package and thermal data	27
4.1	PowerSSO-24 thermal data	27
5	Package and packing information	30
5.1	ECOPACK® packages	30
5.2	Package mechanical data	30
5.3	Packing information	32
6	Order codes	33
7	Revision history	34

List of tables

Table 1.	Pin functions	5
Table 2.	Suggested connections for unused and not connected pins	6
Table 3.	Absolute maximum ratings	7
Table 4.	Thermal data	8
Table 5.	Power section	9
Table 6.	Switching ($V_{CC} = 13V$; $T_j = 25^{\circ}C$)	9
Table 7.	Logic inputs	10
Table 8.	Protections and diagnostics	10
Table 9.	Current sense ($8V < V_{CC} < 18V$)	11
Table 10.	Truth table	16
Table 11.	Electrical transient requirements (part 1/3)	17
Table 12.	Electrical transient requirements (part 2/3)	17
Table 13.	Electrical transient requirements (part 3/3)	17
Table 14.	Thermal parameters	29
Table 15.	PowerSSO-24 mechanical data	31
Table 16.	Device summary	33
Table 17.	Document revision history	34

List of figures

Figure 1.	Block diagram	5
Figure 2.	Configuration diagram (top view)	6
Figure 3.	Current and voltage conventions ⁽¹⁾	7
Figure 4.	Current sense delay characteristics	13
Figure 5.	Switching characteristics	13
Figure 6.	Output voltage drop limitation	13
Figure 7.	Delay response time between rising edge of output current and rising edge of current sense (CS enabled).	14
Figure 8.	I_{OUT}/I_{SENSE} vs I_{OUT}	15
Figure 9.	Maximum current sense ratio drift vs load current	15
Figure 10.	Normal operation	18
Figure 11.	Overload or short to GND	18
Figure 12.	Intermittent overload	19
Figure 13.	T_J evolution in overload or short to GND	19
Figure 14.	Off-state output current	20
Figure 15.	High level input current	20
Figure 16.	Input clamp voltage	20
Figure 17.	Input high level	20
Figure 18.	Input low level	20
Figure 19.	Input hysteresis voltage	20
Figure 20.	On-state resistance vs T_{case}	21
Figure 21.	On-state resistance vs VCC	21
Figure 22.	Undervoltage shutdown	21
Figure 23.	I_{LIMH} vs T_{case}	21
Figure 24.	Turn-on voltage slope	21
Figure 25.	Turn-off voltage slope	21
Figure 26.	CS_DIS high level voltage	22
Figure 27.	CS_DIS low level voltage	22
Figure 28.	CS_DIS clamp voltage	22
Figure 29.	Application schematic ⁽¹⁾	23
Figure 30.	Current sense and diagnostic	25
Figure 31.	Maximum turn-off current versus inductance (for each channel) ⁽¹⁾	26
Figure 32.	PowerSSO-24 PC board ⁽¹⁾	27
Figure 33.	$R_{thj-amb}$ vs PCB copper area in open box free air condition (one channel ON)	27
Figure 34.	PowerSSO-24 thermal impedance junction to ambient single pulse (one channel ON)	28
Figure 35.	Thermal fitting model of a double-channel HSD in PowerSSO-24 ⁽¹⁾	28
Figure 36.	PowerSSO-24 package dimensions	30
Figure 37.	PowerSSO-24 tube shipment (no suffix)	32
Figure 38.	PowerSSO-24 tape and reel shipment (suffix "TR")	32

1 Block diagram and pin description

Figure 1. Block diagram

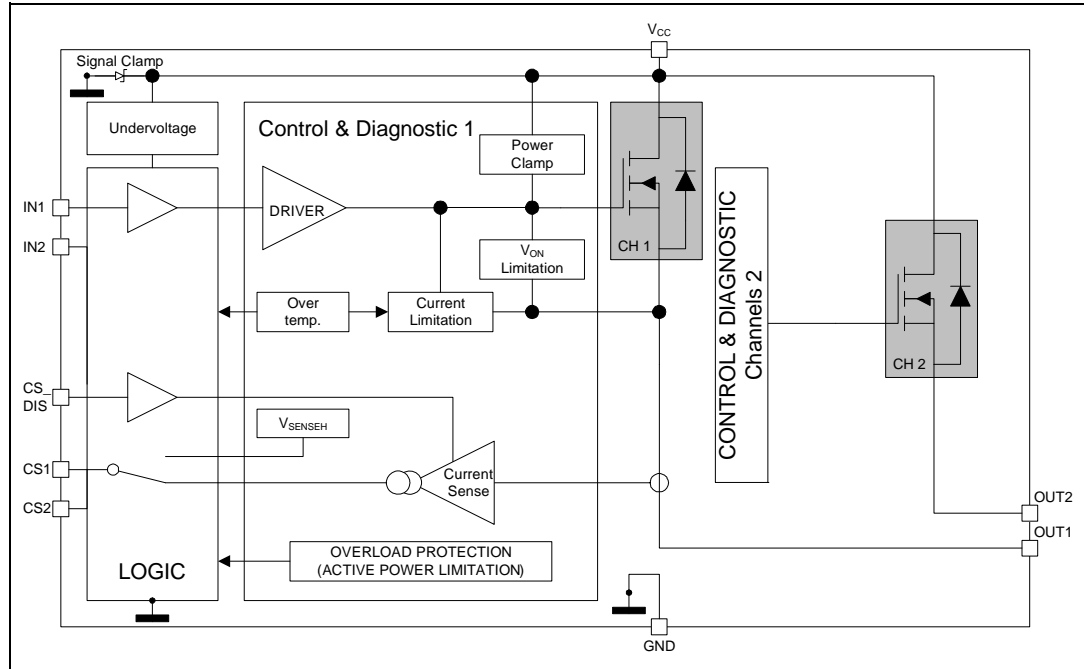

Table 1. Pin functions

Name	Function
V _{CC}	Battery connection.
OUTPUT _{1,2}	Power output.
GND	Ground connection. Must be reverse battery protected by an external diode / resistor network.
INPUT _{1,2}	Voltage controlled input pin with hysteresis, CMOS compatible. Controls output switch state.
CURRENT SENSE _{1,2}	Analog current sense pin; delivers a current proportional to the load current.
CS_DIS	Active high CMOS compatible pin to disable the current sense pin.

Figure 2. Configuration diagram (top view)

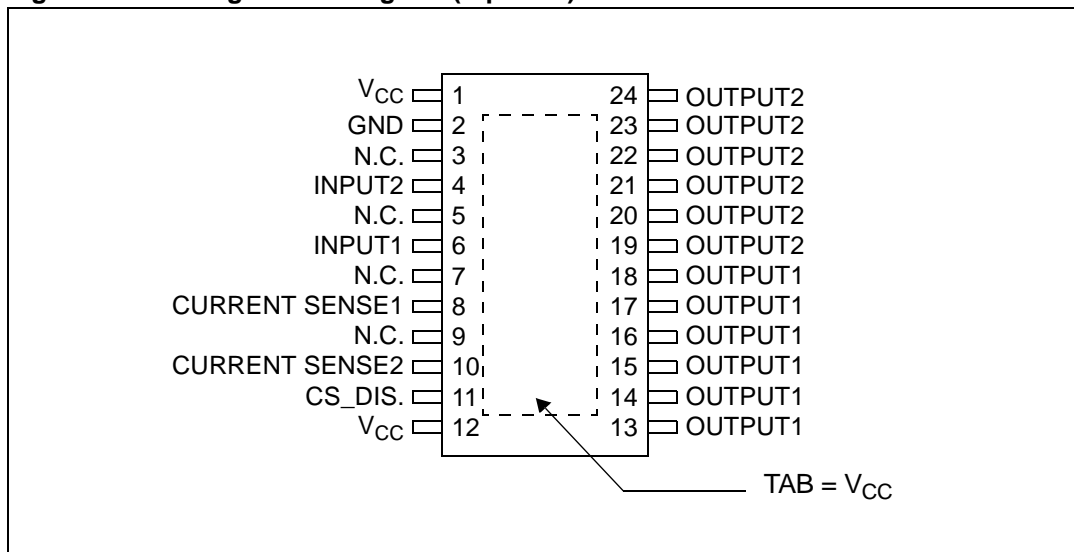
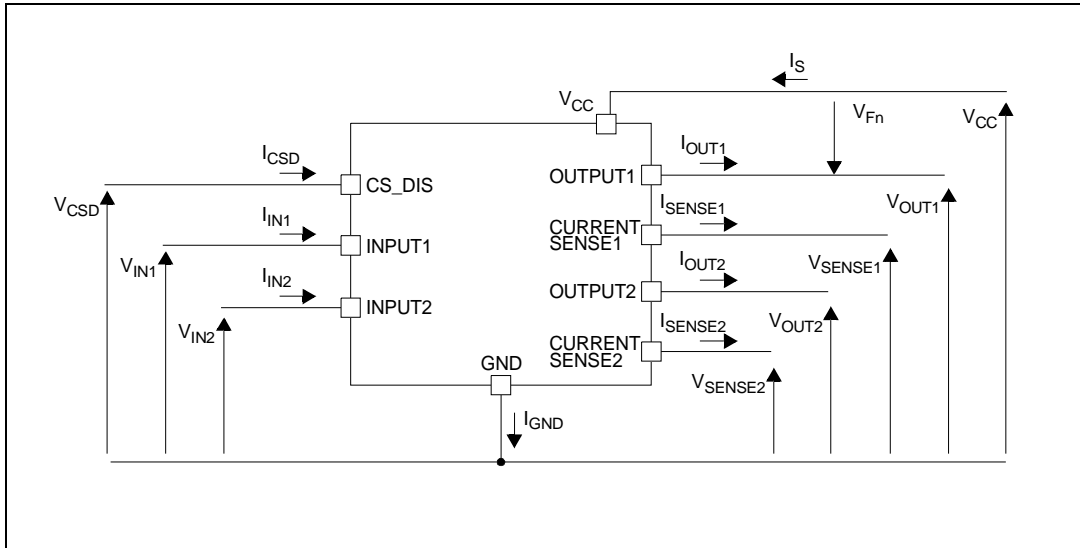

Table 2. Suggested connections for unused and not connected pins

Connection / pin	Current sense	N.C.	Output	Input	CS_DIS
Floating	Not allowed	X	X	X	X
To ground	Through 1kΩ resistor	X	Through 22kΩ resistor	Through 10kΩ resistor	Through 10kΩ resistor

2 Electrical specification

Figure 3. Current and voltage conventions⁽¹⁾



1. $V_{Fn} = V_{OUTn} - V_{CC}$ during reverse battery condition.

2.1 Absolute maximum ratings

Stressing the device above the rating listed in the “Absolute maximum ratings” table may cause permanent damage to the device. These are stress ratings only and operation of the device at these or any other conditions above those indicated in the Operating sections of this specification is not implied. Exposure to the conditions in table below for extended periods may affect device reliability. Refer also to the STMicroelectronics SURE Program and other relevant quality document.

Table 3. Absolute maximum ratings

Symbol	Parameter	Value	Unit
V_{CC}	DC supply voltage	41	V
$-V_{CC}$	Reverse DC supply voltage	0.3	
$-I_{GND}$	DC reverse ground pin current	200	mA
I_{OUT}	DC output current	Internally limited	A
$-I_{OUT}$	Reverse DC output current	24	
I_{IN}	DC input current	-1 to 10	mA
I_{CSD}	DC current sense disable input current		
$-I_{CSENSE}$	DC reverse CS pin current	200	
V_{CSENSE}	Current sense maximum voltage	$V_{CC} - 41$ to $+V_{CC}$	V
E_{MAX}	Maximum switching energy (single pulse) ($L = 0.8$ mH; $R_L = 0\Omega$; $V_{bat} = 13.5V$; $T_{jstart} = 150^\circ C$; $I_{OUT} = I_{limL}(Typ.)$)	140	mJ

Table 3. Absolute maximum ratings (continued)

Symbol	Parameter	Value	Unit
V_{ESD}	Electrostatic discharge (Human Body Model: R = 1.5k Ω ; C = 100pF)		
	– INPUT	4000	V
	– CURRENT SENSE	2000	V
	– CS_DIS	4000	V
	– OUTPUT	5000	V
	– V_{CC}	5000	V
V_{ESD}	Charge device model (CDM-AEC-Q100-011)	750	V
T_j	Junction operating temperature	- 40 to 150	°C
T_{stg}	Storage temperature	- 55 to 150	

2.2 Thermal data

Table 4. Thermal data

Symbol	Parameter	Max. value	Unit
$R_{thj-case}$	Thermal resistance junction-case (with one channel ON)	1.35	°C/W
$R_{thj-amb}$	Thermal resistance junction-ambient	See Figure 33	

2.3 Electrical characteristics

Values specified in this section are for $8V < V_{CC} < 28V$; $-40^{\circ}C < T_j < 150^{\circ}C$, unless otherwise stated.

Table 5. Power section

Symbol	Parameter	Test conditions	Min.	Typ.	Max.	Unit
V_{CC}	Operating supply voltage		4.5	13	28	V
V_{USD}	Undervoltage shutdown			3.5	4.5	
$V_{USDhyst}$	Undervoltage shutdown hysteresis			0.5		
R_{ON}	On-state resistance ⁽¹⁾	$I_{OUT} = 3A$; $T_j = 25^{\circ}C$			25	m Ω
		$I_{OUT} = 3A$; $T_j = 150^{\circ}C$			50	
		$I_{OUT} = 3A$; $V_{CC} = 5V$; $T_j = 25^{\circ}C$			35	
V_{clamp}	Clamp voltage	$I_S = 20$ mA	41	46	52	V
I_S	Supply current	Off-state; $V_{CC} = 13V$; $T_j = 25^{\circ}C$; $V_{IN} = V_{OUT} = V_{SENSE} = V_{CSD} = 0V$		2 ⁽²⁾	5 ⁽²⁾	μ A
		On-state; $V_{CC} = 13V$; $V_{IN} = 5V$; $I_{OUT} = 0A$		3	6	mA
$I_{L(off1)}$	Off-state output current ⁽¹⁾	$V_{IN} = V_{OUT} = 0V$; $V_{CC} = 13V$; $T_j = 25^{\circ}C$	0	0.01	3	μ A
		$V_{IN} = V_{OUT} = 0V$; $V_{CC} = 13V$; $T_j = 125^{\circ}C$	0		5	
V_F	Output - V_{CC} diode voltage ⁽¹⁾	$-I_{OUT} = 4$ A; $T_j = 150^{\circ}C$			0.7	V

1. For each channel.
2. PowerMOS leakage included.

Table 6. Switching ($V_{CC} = 13V$; $T_j = 25^{\circ}C$)

Symbol	Parameter	Test conditions	Min.	Typ.	Max.	Unit
$t_{d(on)}$	Turn-on delay time	$R_L = 4.3 \Omega$ (see Figure 5)		20		μ s
$t_{d(off)}$	Turn-off delay time			40		
$(dV_{OUT}/dt)_{on}$	Turn-on voltage slope	$R_L = 4.3 \Omega$		See Figure 24		V/ μ s
$(dV_{OUT}/dt)_{off}$	Turn-off voltage slope			See Figure 25		
W_{ON}	Switching energy losses during t_{WON}	$R_L = 4.3 \Omega$ (see Figure 5)		0.6		mJ
W_{OFF}	Switching energy losses during t_{WOFF}			0.35		

Table 7. Logic inputs

Symbol	Parameter	Test conditions	Min.	Typ.	Max.	Unit
V_{IL}	Input low level voltage				0.9	V
I_{IL}	Low level input current	$V_{IN} = 0.9V$	1			μA
V_{IH}	Input high level voltage		2.1			V
I_{IH}	High level input current	$V_{IN} = 2.1V$			10	μA
$V_{I(hyst)}$	Input hysteresis voltage		0.25			V
V_{ICL}	Input clamp voltage	$I_{IN} = 1mA$	5.5		7	
		$I_{IN} = -1mA$		-0.7		
V_{CSDL}	CS_DIS low level voltage				0.9	μA
I_{CSDL}	Low level CS_DIS current	$V_{CSD} = 0.9V$	1			
V_{CSDH}	CS_DIS high level voltage		2.1			V
I_{CSDH}	High level CS_DIS current	$V_{CSD} = 2.1V$			10	μA
$V_{CSD(hyst)}$	CS_DIS hysteresis voltage		0.25			V
V_{CSCL}	CS_DIS clamp voltage	$I_{CSD} = 1mA$	5.5		7	
		$I_{CSD} = -1mA$		-0.7		

Table 8. Protections and diagnostics (1)

Symbol	Parameter	Test conditions	Min.	Typ.	Max.	Unit
I_{LIMH}	DC short circuit current	$V_{CC} = 13V$	43	60	85	A
		$5V < V_{CC} < 28V$				
I_{LIML}	Short circuit current during thermal cycling	$V_{CC} = 13V$; $T_R < T_j < T_{TSD}$		15		
T_{TSD}	Shutdown temperature		150	175	200	°C
T_R	Reset temperature		$T_{RS} + 1$	$T_{RS} + 5$		
T_{RS}	Thermal reset of STATUS		135			
T_{HYST}	Thermal hysteresis ($T_{TSD} - T_R$)			7		
V_{DEMAG}	Turn-Off output voltage clamp	$I_{OUT} = 2A$; $V_{IN} = 0$; $L = 6 mH$	$V_{CC} - 41$	$V_{CC} - 46$	$V_{CC} - 52$	V
V_{ON}	Output voltage drop limitation	$I_{OUT} = 0.1A$; $T_j = -40^\circ C$ to $+150^\circ C$ (see Figure 6)		25		mV

1. To ensure long term reliability under heavy overload or short circuit conditions, protection and related diagnostic signals must be used together with a proper software strategy. If the device is subjected to abnormal conditions, this software must limit the duration and number of activation cycles.

Table 9. Current sense ($8V < V_{CC} < 18V$)

Symbol	Parameter	Test conditions	Min.	Typ.	Max.	Unit
K_{LED}	I_{OUT}/I_{SENSE}	$I_{OUT} = 0.05A$; $V_{SENSE} = 0.5V$; $V_{CSD} = 0V$; $T_j = -40^{\circ}C$ to $150^{\circ}C$	1240	3350	4960	
K_0	I_{OUT}/I_{SENSE}	$I_{OUT} = 0.5A$; $V_{SENSE} = 0.5V$; $V_{CSD} = 0V$; $T_j = -40^{\circ}C$ to $150^{\circ}C$	1860	3150	4600	
K_1	I_{OUT}/I_{SENSE}	$I_{OUT} = 2 A$; $V_{SENSE} = 4 V$; $V_{CSD} = 0V$; $T_j = -40^{\circ}C$ to $150^{\circ}C$ $T_j = 25^{\circ}C$ to $150^{\circ}C$	2100	3100	4400	
			2250	3100	3850	
$dK_1/K_1^{(1)}$	Current sense ratio drift	$I_{OUT} = 2 A$; $V_{SENSE} = 4 V$; $V_{CSD} = 0V$; $T_j = -40^{\circ}C$ to $150^{\circ}C$	-13		13	%
K_2	I_{OUT}/I_{SENSE}	$I_{OUT} = 3 A$; $V_{SENSE} = 4V$; $V_{CSD} = 0V$; $T_j = -40^{\circ}C$ to $150^{\circ}C$ $T_j = 25^{\circ}C$ to $150^{\circ}C$	2200	3000	4100	
			2450	3000	3550	
$dK_2/K_2^{(1)}$	Current sense ratio drift	$I_{OUT} = 3 A$; $V_{SENSE} = 4V$; $V_{CSD} = 0V$; $T_j = -40^{\circ}C$ to $150^{\circ}C$	-12		12	%
K_3	I_{OUT}/I_{SENSE}	$I_{OUT} = 10 A$; $V_{SENSE} = 4V$; $V_{CSD} = 0V$; $T_j = -40^{\circ}C$ to $150^{\circ}C$ $T_j = 25^{\circ}C$ to $150^{\circ}C$	2550	2850	3280	
			2650	2850	3180	
$dK_3/K_3^{(1)}$	Current sense ratio drift	$I_{OUT} = 10 A$; $V_{SENSE} = 4V$; $V_{CSD} = 0V$; $T_j = -40^{\circ}C$ to $150^{\circ}C$	-6		+6	%
I_{SENSE0}	Analog sense leakage current	$I_{OUT} = 0A$; $V_{SENSE} = 0V$; $V_{CSD} = 5V$; $V_{IN} = 0V$; $T_j = -40^{\circ}C$ to $150^{\circ}C$	0		1	μA
		$V_{CSD} = 0V$; $V_{IN} = 5V$; $T_j = -40^{\circ}C$ to $150^{\circ}C$	0		2	μA
		$I_{OUT} = 2A$; $V_{SENSE} = 0V$; $V_{CSD} = 5V$; $V_{IN} = 5V$; $T_j = -40^{\circ}C$ to $150^{\circ}C$	0		1	μA
I_{OL}	Open-load on-state current detection threshold	$V_{IN} = 5V$, $8V < V_{CC} < 18V$ $I_{SENSE} = 5 \mu A$	5		30	mA
V_{SENSE}	Max analog sense output voltage	$I_{OUT} = 3 A$; $V_{CSD} = 0V$	5			V
V_{SENSEH}	Analog sense output voltage in fault condition ⁽²⁾	$V_{CC} = 13V$; $R_{SENSE} = 3.9k\Omega$		8		
I_{SENSEH}	Analog sense output current in fault condition ⁽²⁾	$V_{CC} = 13V$; $V_{SENSE} = 5V$		9		mA

Table 9. Current sense (8V < V_{CC} < 18V) (continued)

Symbol	Parameter	Test conditions	Min.	Typ.	Max.	Unit
t _{DSENSE1H}	Delay response time from falling edge of CS_DIS pin	V _{SENSE} < 4V, 0.5 < I _{OUT} < 10A I _{SENSE} = 90% of I _{SENSEMAX} (see Figure 4)		30	100	μs
t _{DSENSE1L}	Delay response time from rising edge of CS_DIS pin	V _{SENSE} < 4V, 0.5 < I _{OUT} < 10A I _{SENSE} = 10% of I _{SENSEMAX} (see Figure 4)		5	20	
t _{DSENSE2H}	Delay response time from rising edge of INPUT pin	V _{SENSE} < 4V, 0.5 < I _{OUT} < 10A I _{SENSE} = 90% of I _{SENSEMAX} (see Figure 4)		80	300	
Δt _{DSENSE2H}	Delay response time between rising edge of output current and rising edge of current sense	V _{SENSE} < 4V, I _{SENSE} = 90% of I _{SENSEMAX} , I _{OUT} = 90% of I _{OUTMAX} , I _{OUTMAX} = 3A (see Figure 7)			110	
t _{DSENSE2L}	Delay response time from falling edge of INPUT pin	V _{SENSE} < 4V, 0.5 < I _{OUT} < 10A I _{SENSE} = 10% of I _{SENSEMAX} (see Figure 4)		70	250	

- Parameter guaranteed by design; it is not tested.
- Fault condition includes: power limitation and overtemperature.

Figure 4. Current sense delay characteristics

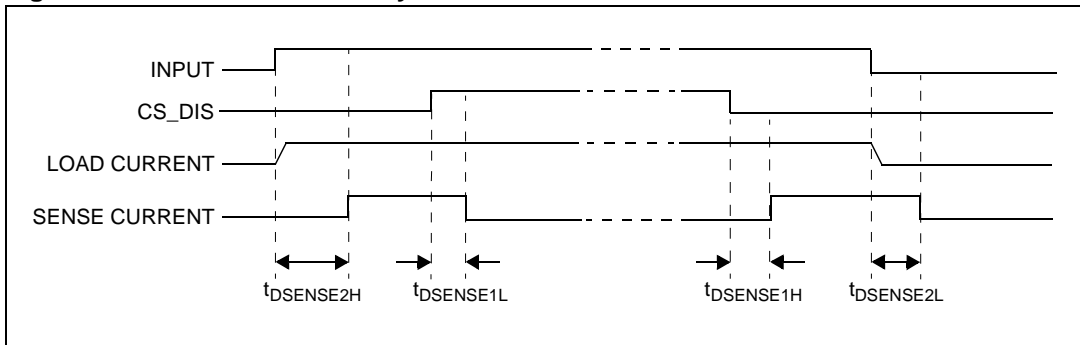

Figure 5. Switching characteristics

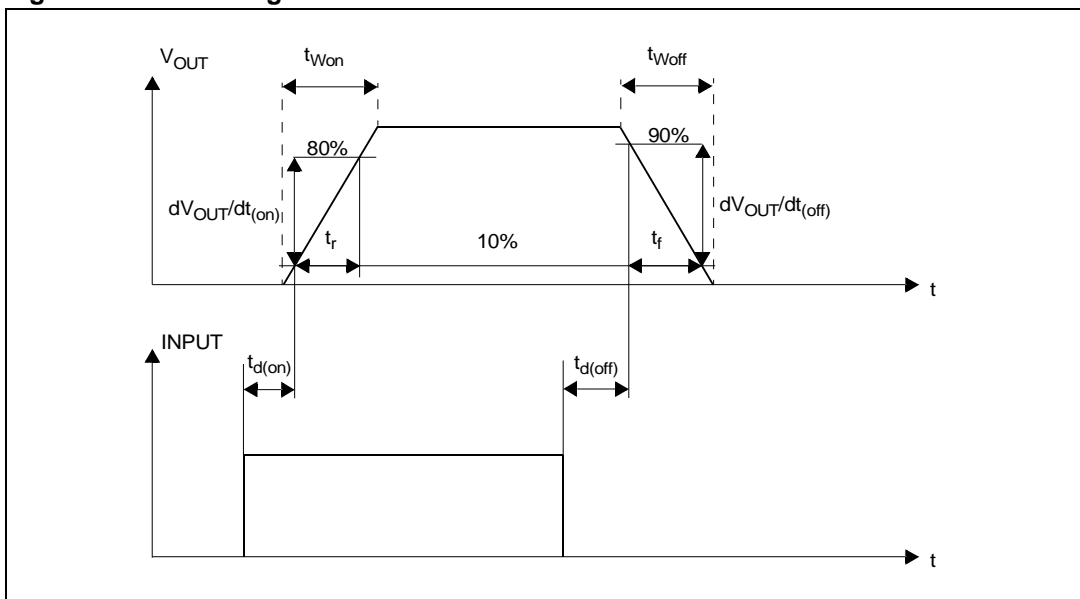

Figure 6. Output voltage drop limitation

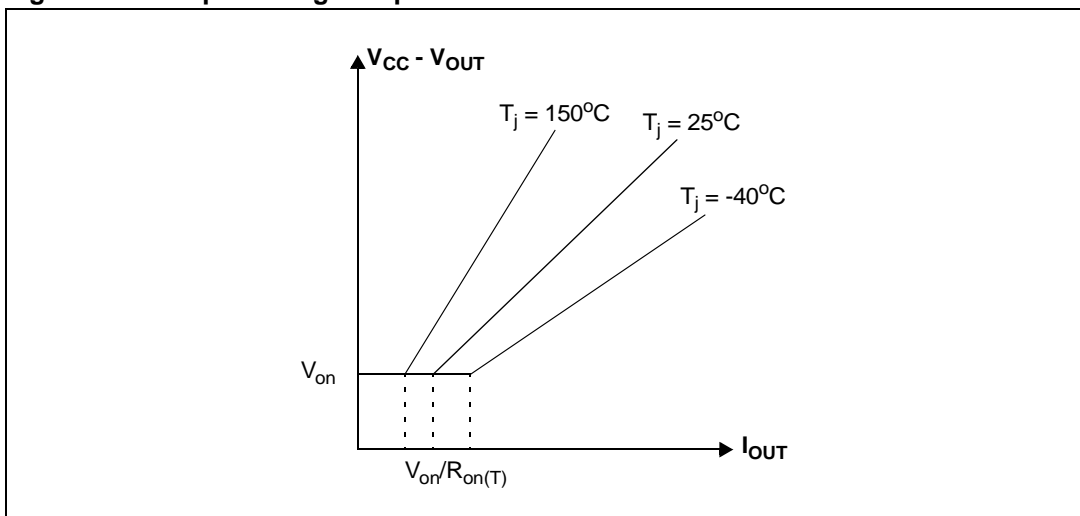

Figure 7. Delay response time between rising edge of output current and rising edge of current sense (CS enabled)

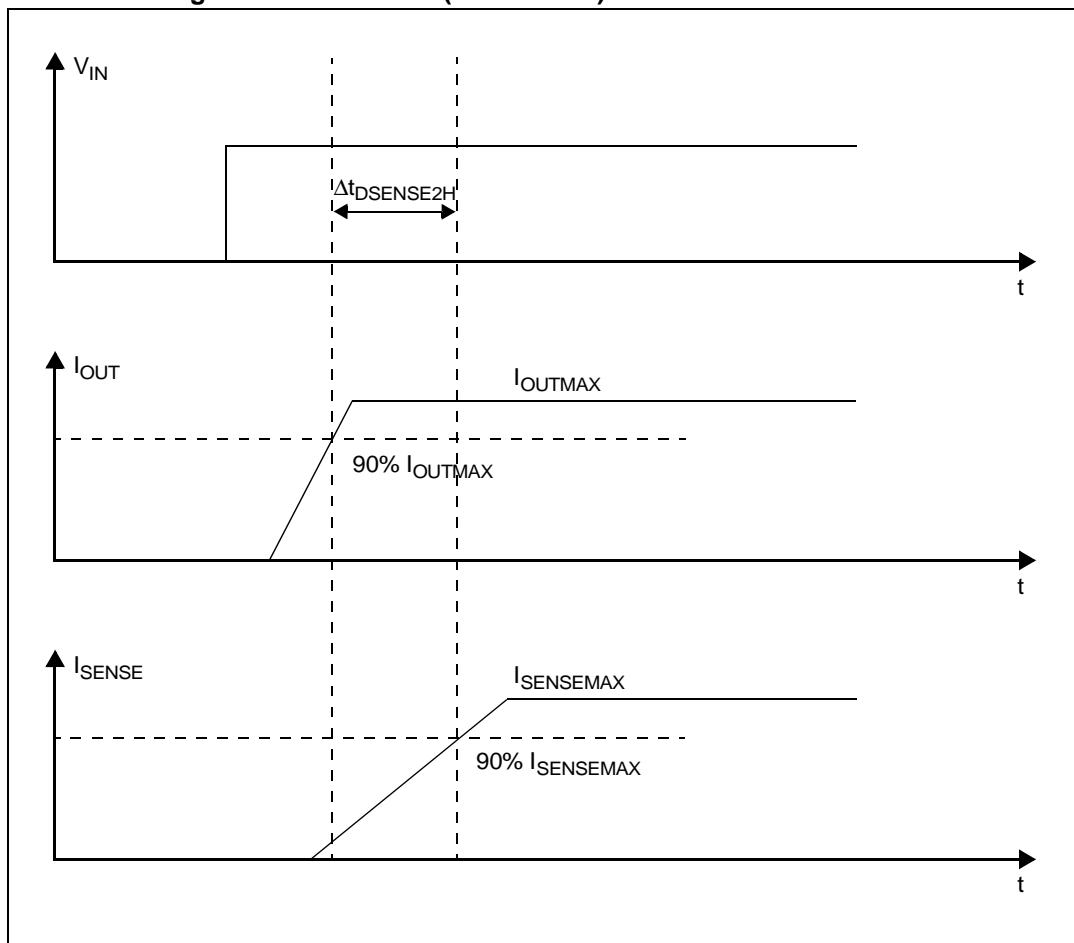

Figure 8. I_{OUT}/I_{SENSE} vs I_{OUT}

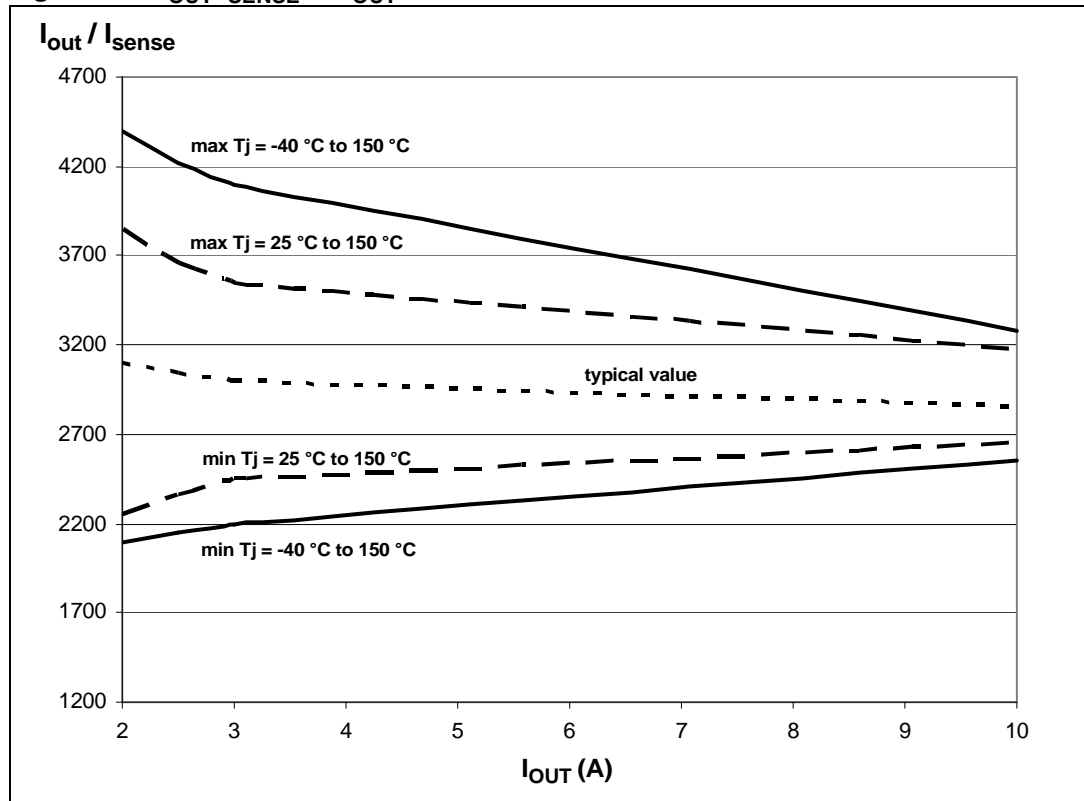
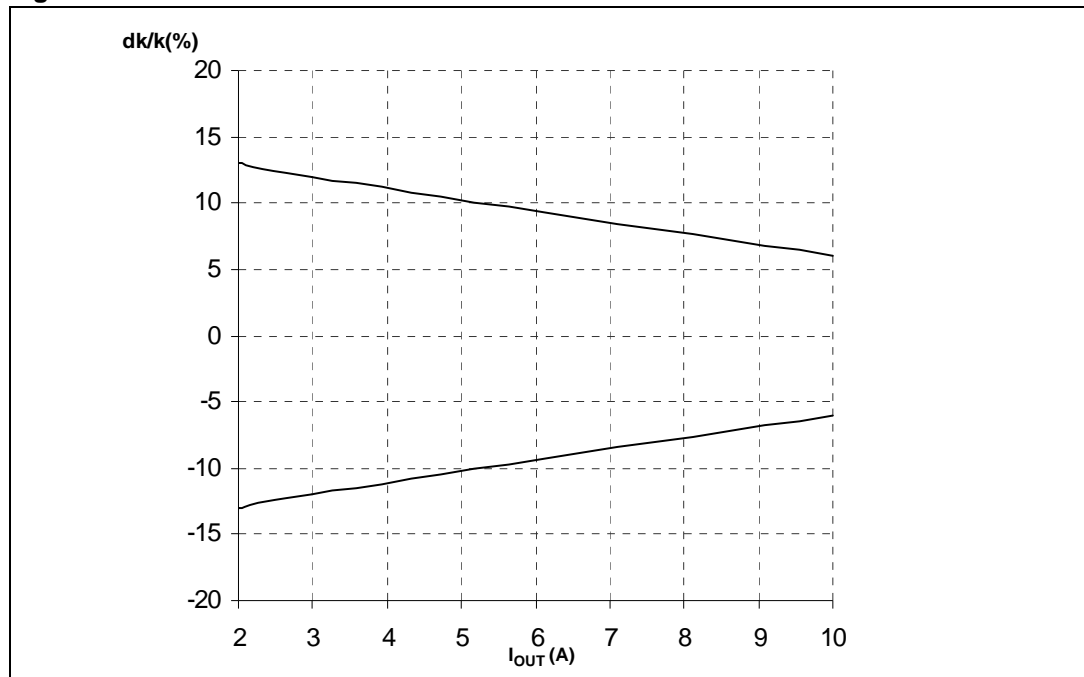

Figure 9. Maximum current sense ratio drift vs load current



Note: Parameter guaranteed by design; it is not tested.

Table 10. Truth table

Conditions	Input	Output	Sense ($V_{CSD}=0V$) ⁽¹⁾
Normal operation	L	L	0
	H	H	Nominal
Overtemperature	L	L	0
	H	L	V_{SENSEH}
Undervoltage	L	L	0
	H	L	0
Overload	H	X (no power limitation)	Nominal
	H	Cycling (power limitation)	V_{SENSEH}
Short circuit to GND (Power limitation)	L	L	0
	H	L	V_{SENSEH}
Negative output voltage clamp	L	L	0

1. If the V_{CSD} is high, the SENSE output is at a high impedance, its potential depends on leakage currents and external circuit.

Table 11. Electrical transient requirements (part 1/3)

ISO 7637-2: 2004(E) Test pulse	Test levels ⁽¹⁾		Number of pulses or test times	Burst cycle / pulse repetition time		Delays and Impedance
	III	IV		Min.	Max.	
1	-75V	-100V	5000 pulses	0.5s	5s	2 ms, 10Ω
2a	+37V	+50V	5000 pulses	0.2s	5s	50μs, 2Ω
3a	-100V	-150V	1h	90ms	100ms	0.1μs, 50Ω
3b	+75V	+100V	1h	90ms	100ms	0.1μs, 50Ω
4	-6V	-7V	1 pulse			100ms, 0.01Ω
5b ⁽²⁾	+65V	+87V	1 pulse			400ms, 2Ω

1. The above test levels must be considered referred to $V_{CC} = 13.5V$ except for pulse 5b.
2. Valid in case of external load dump clamp: 40V maximum referred to ground.

Table 12. Electrical transient requirements (part 2/3)

ISO 7637-2: 2004E Test pulse	Test level results	
	III	VI
1	C	C
2a	C	C
3a	C	C
3b	C	C
4	C	C
5b ⁽¹⁾	C	C

1. Valid in case of external load dump clamp: 40V maximum referred to ground.

Table 13. Electrical transient requirements (part 3/3)

Class	Contents
C	All functions of the device performed as designed after exposure to disturbance.
E	One or more functions of the device did not perform as designed after exposure to disturbance and cannot be returned to proper operation without replacing the device.

2.4 Waveforms

Figure 10. Normal operation

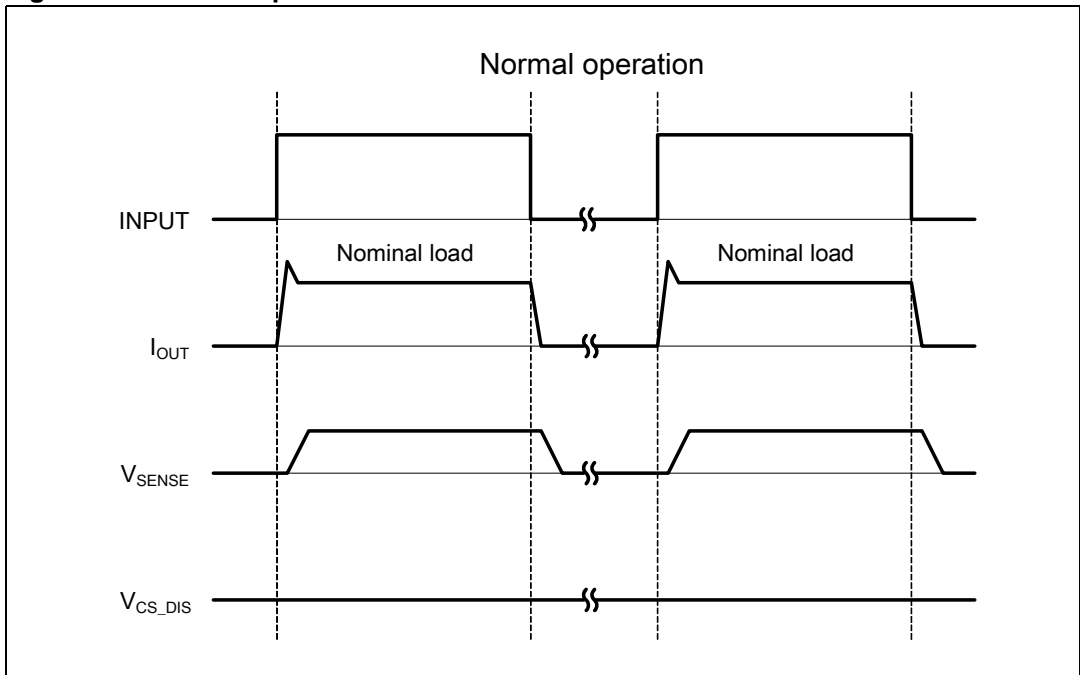

Figure 11. Overload or short to GND

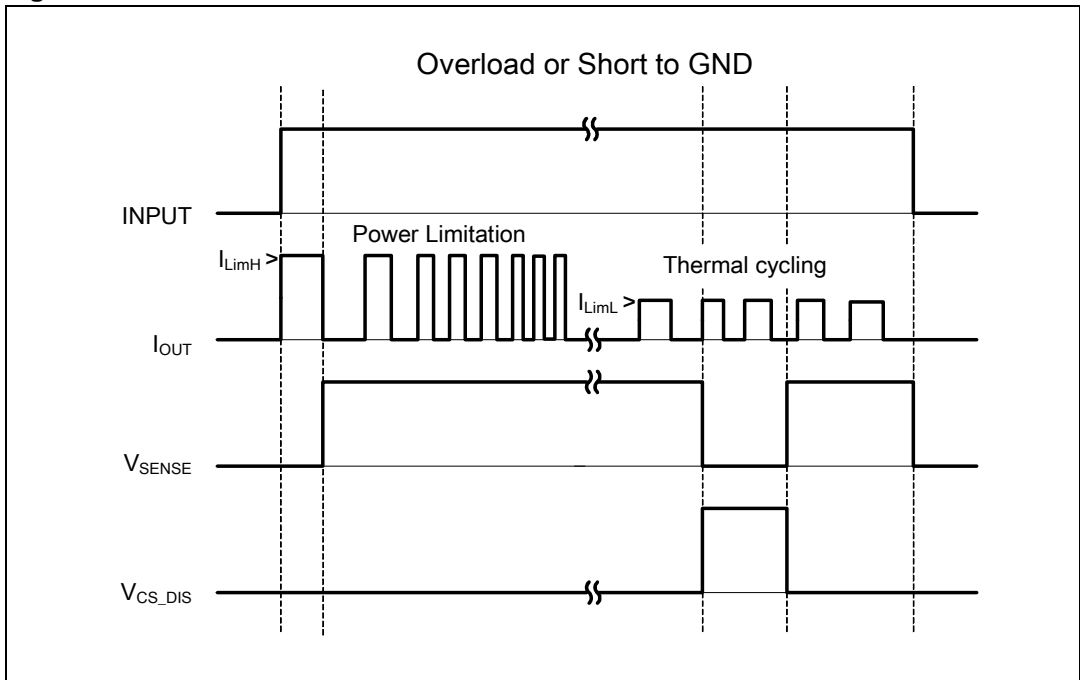

Figure 12. Intermittent overload

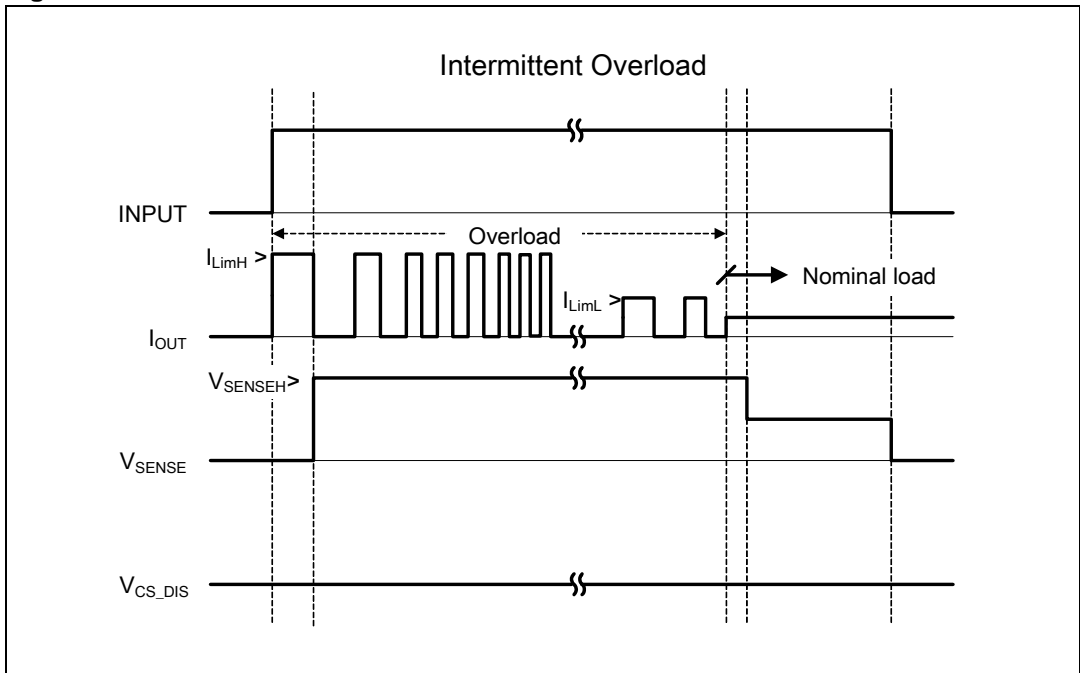
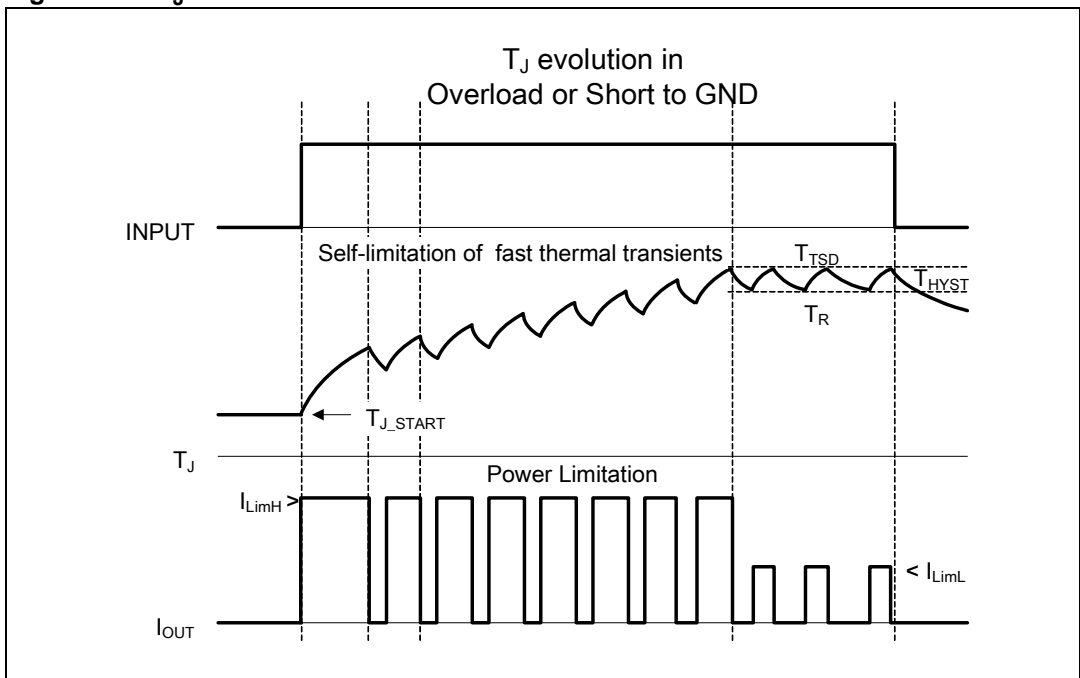

Figure 13. T_J evolution in overload or short to GND



2.5 Electrical characteristics curves

Figure 14. Off-state output current

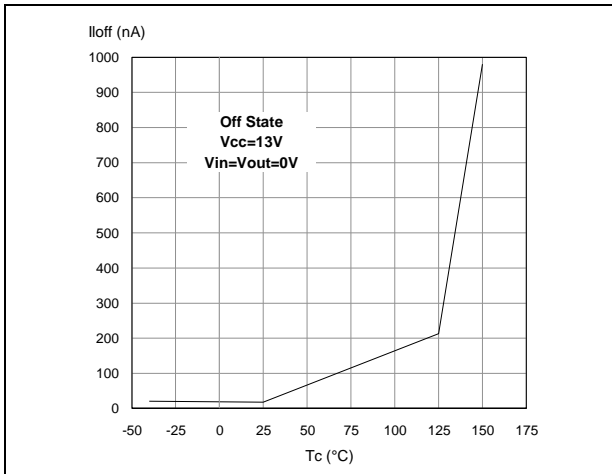

Figure 15. High level input current

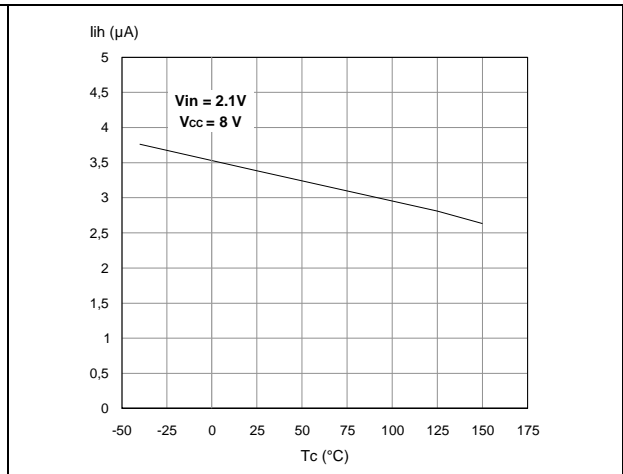

Figure 16. Input clamp voltage

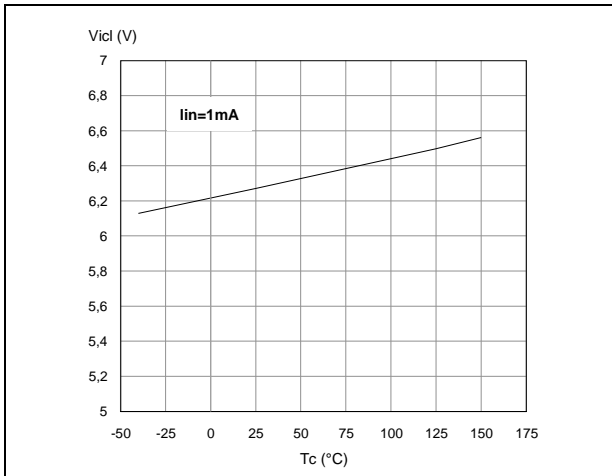

Figure 17. Input high level

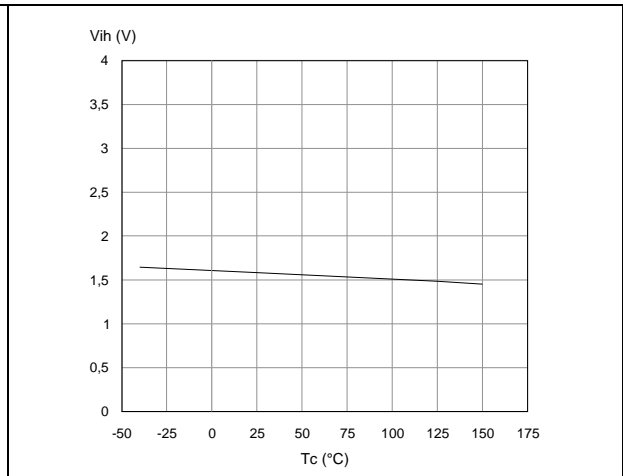

Figure 18. Input low level

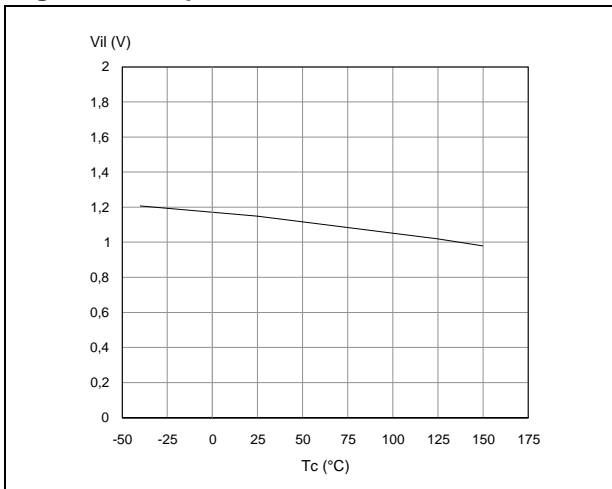

Figure 19. Input hysteresis voltage

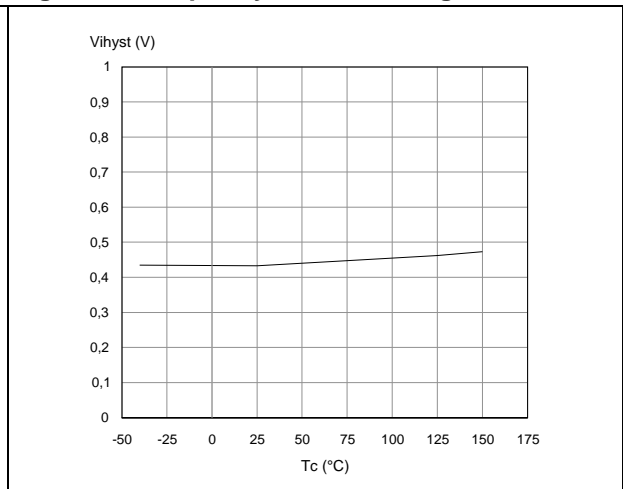

Figure 20. On-state resistance vs T_{case}

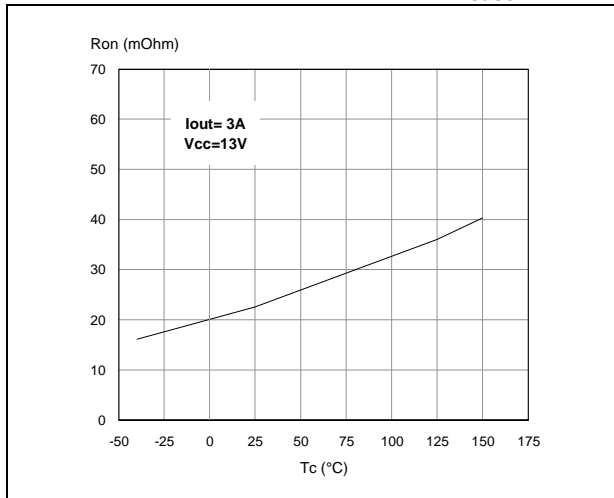

Figure 21. On-state resistance vs V_{CC}

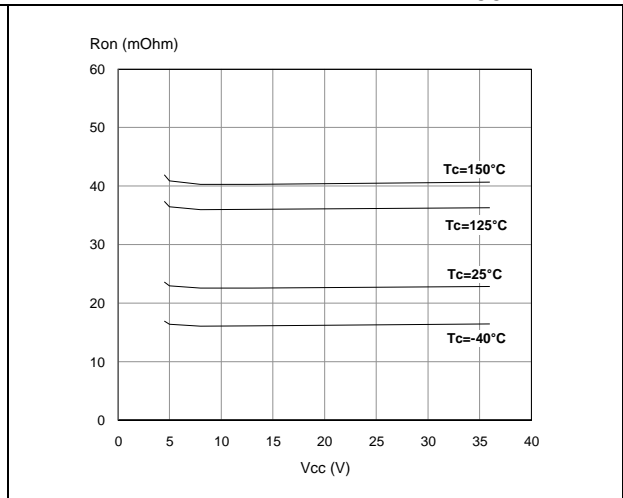

Figure 22. Undervoltage shutdown

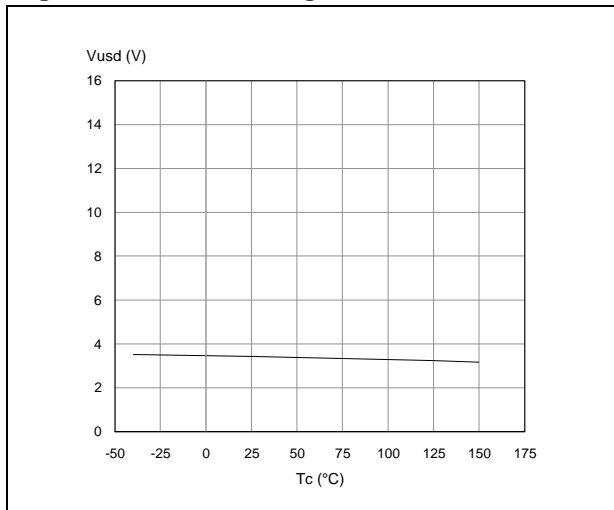

Figure 23. I_{LIMH} vs T_{case}

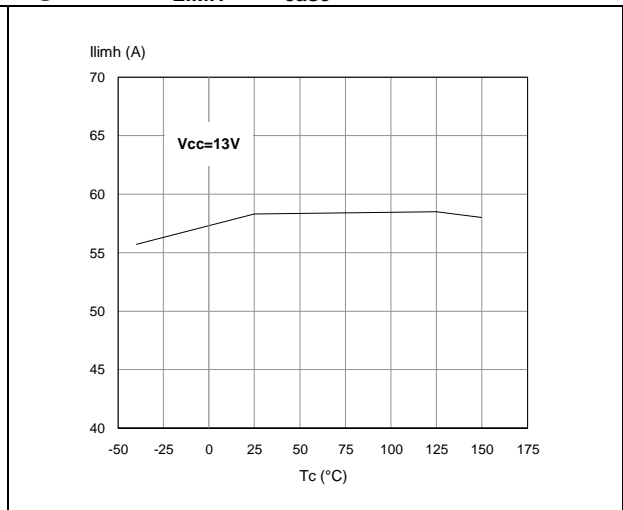

Figure 24. Turn-on voltage slope

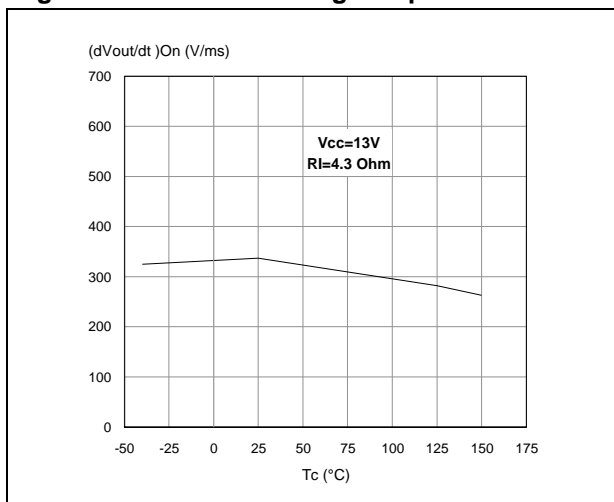

Figure 25. Turn-off voltage slope

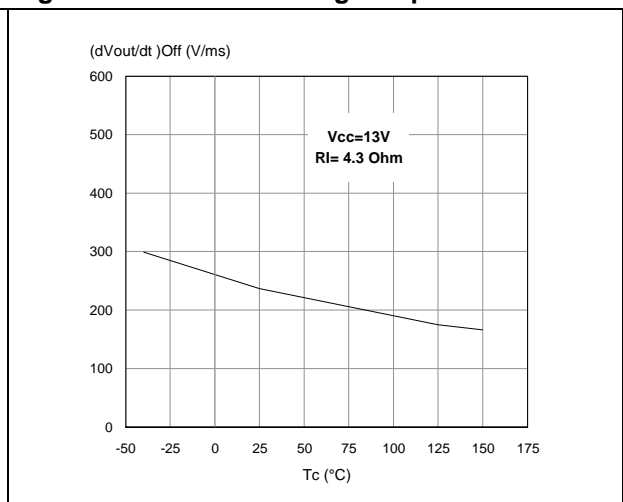

Figure 26. CS_DIS high level voltage

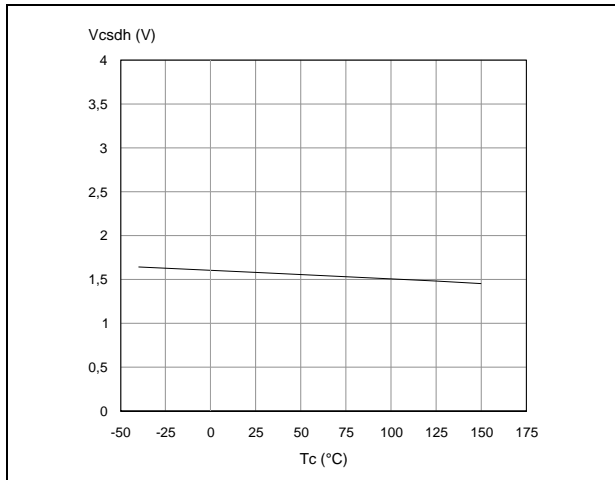

Figure 27. CS_DIS low level voltage

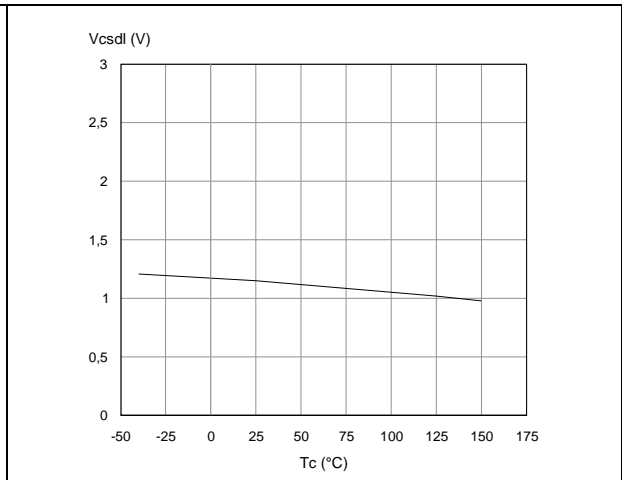
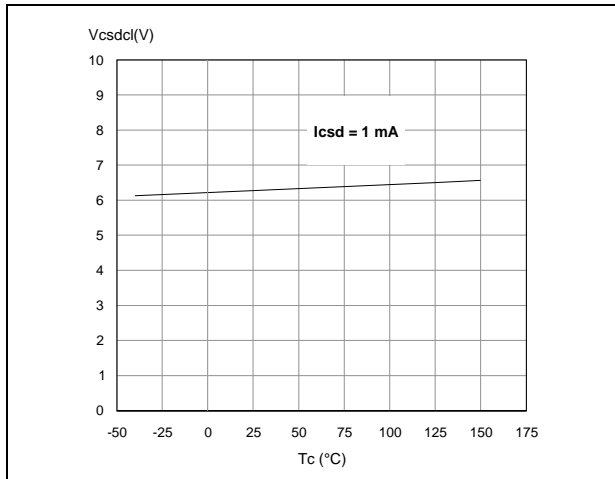
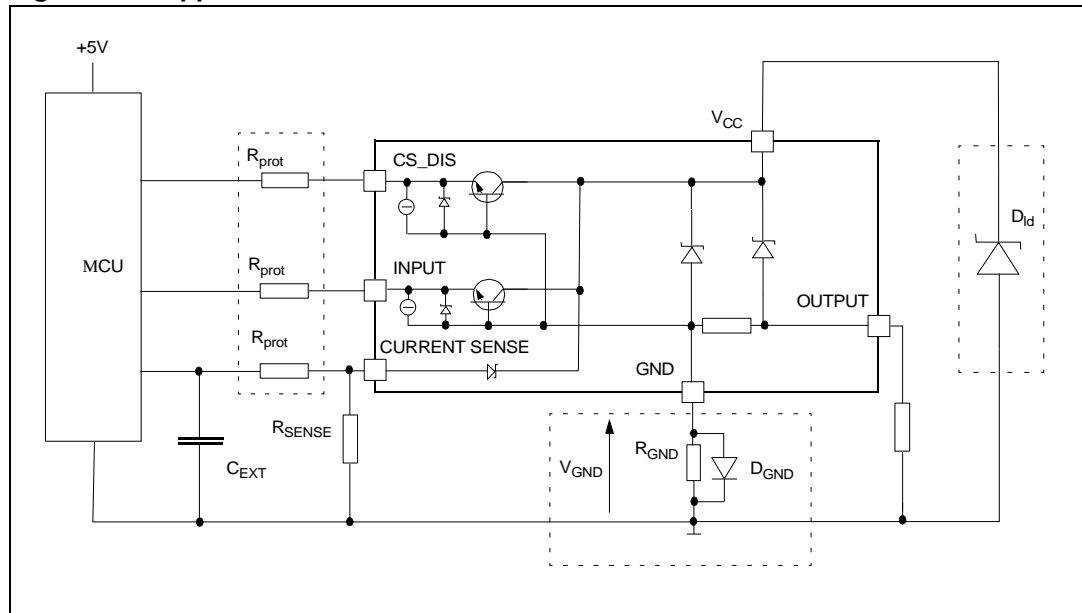

Figure 28. CS_DIS clamp voltage



3 Application information

Figure 29. Application schematic⁽¹⁾



1. Channel 2 has the same internal circuit as channel 1.

3.1 GND protection network against reverse battery

This section provides two solutions for implementing a ground protection network against reverse battery.

3.1.1 Solution 1: resistor in the ground line (R_{GND} only)

This can be used with any type of load.

The following is an indication on how to dimension the R_{GND} resistor.

1. $R_{GND} \leq 600\text{mV} / (I_{S(on)max})$
2. $R_{GND} \geq (-V_{CC}) / (-I_{GND})$

where -I_{GND} is the DC reverse ground pin current and can be found in the absolute maximum rating section of the device datasheet.

Power dissipation in R_{GND} (when V_{CC}<0: during reverse battery situations) is:

$$P_D = (-V_{CC})^2 / R_{GND}$$

This resistor can be shared amongst several different HSDs. Please note that the value of this resistor should be calculated with formula (1) where I_{S(on)max} becomes the sum of the maximum On-state currents of the different devices.

Please note that if the microprocessor ground is not shared by the device ground then the R_{GND} produces a shift (I_{S(on)max} * R_{GND}) in the input thresholds and the status output values. This shift varies depending on how many devices are On in the case of several high side drivers sharing the same R_{GND}.

If the calculated power dissipation leads to a large resistor or several devices have to share the same resistor then ST suggests to utilize Solution 2 (see below).

3.1.2 Solution 2: diode (D_{GND}) in the ground line

A resistor ($R_{GND}=1k\Omega$) should be inserted in parallel to D_{GND} if the device drives an inductive load.

This small signal diode can be safely shared amongst several different HSDs. Also in this case, the presence of the ground network produces a shift ($\approx 600mV$) in the input threshold and in the status output values if the microprocessor ground is not common to the device ground. This shift not varies if more than one HSD shares the same diode/resistor network.

3.2 Load dump protection

D_{ld} is necessary (Voltage Transient Suppressor) if the load dump peak voltage exceeds the V_{CC} max DC rating. The same applies if the device is subject to transients on the V_{CC} line that are greater than the ones shown in the ISO 7637-2: 2004(E) table.

3.3 MCU I/Os protection

If a ground protection network is used and negative transient are present on the V_{CC} line, the control pins is pulled negative. ST suggests to insert a resistor (R_{prot}) in line to prevent the MCU I/Os pins to latch-up.

The value of these resistors is a compromise between the leakage current of MCU and the current required by the HSD I/Os (Input levels compatibility) with the latch-up limit of MCU I/Os:

$$-V_{CCpeak}/I_{latchup} \leq R_{prot} \leq (V_{OH\mu C} - V_{IH} - V_{GND}) / I_{IHmax}$$

Calculation example:

For $V_{CCpeak} = -100V$ and $I_{latchup} \geq 20mA$; $V_{OH\mu C} \geq 4.5V$

$$5k\Omega \leq R_{prot} \leq 180k\Omega$$

Recommended values: $R_{prot} = 10k\Omega$, $C_{EXT} = 10nF$.

3.4 Current sense and diagnostic

The current sense pin performs a double function (see [Figure 30: Current sense and diagnostic](#)):

- **Current mirror of the load current in normal operation**, delivering a current proportional to the load one according to a know ratio K_x .
The current I_{SENSE} can be easily converted to a voltage V_{SENSE} by means of an external resistor R_{SENSE} . Linearity between I_{OUT} and V_{SENSE} is ensured up to 5V minimum (see parameter V_{SENSE} in [Table 9: Current sense \(8V < VCC < 18V\)](#)). The current sense accuracy depends on the output current (refer to current sense electrical characteristics [Table 9: Current sense \(8V < VCC < 18V\)](#)).
- **Diagnostic flag in fault conditions**, delivering a fixed voltage V_{SENSEH} up to a maximum current I_{SENSEH} in case of the following fault conditions (refer to [Truth table](#)):
 - Power limitation activation
 - Overtemperature

A logic level high on CS_DIS pin sets at the same time all the current sense pins of the device in a high impedance state, thus disabling the current monitoring and diagnostic detection. This feature allows multiplexing of the microcontroller analog inputs by sharing of sense resistance and ADC line among different devices.

Figure 30. Current sense and diagnostic

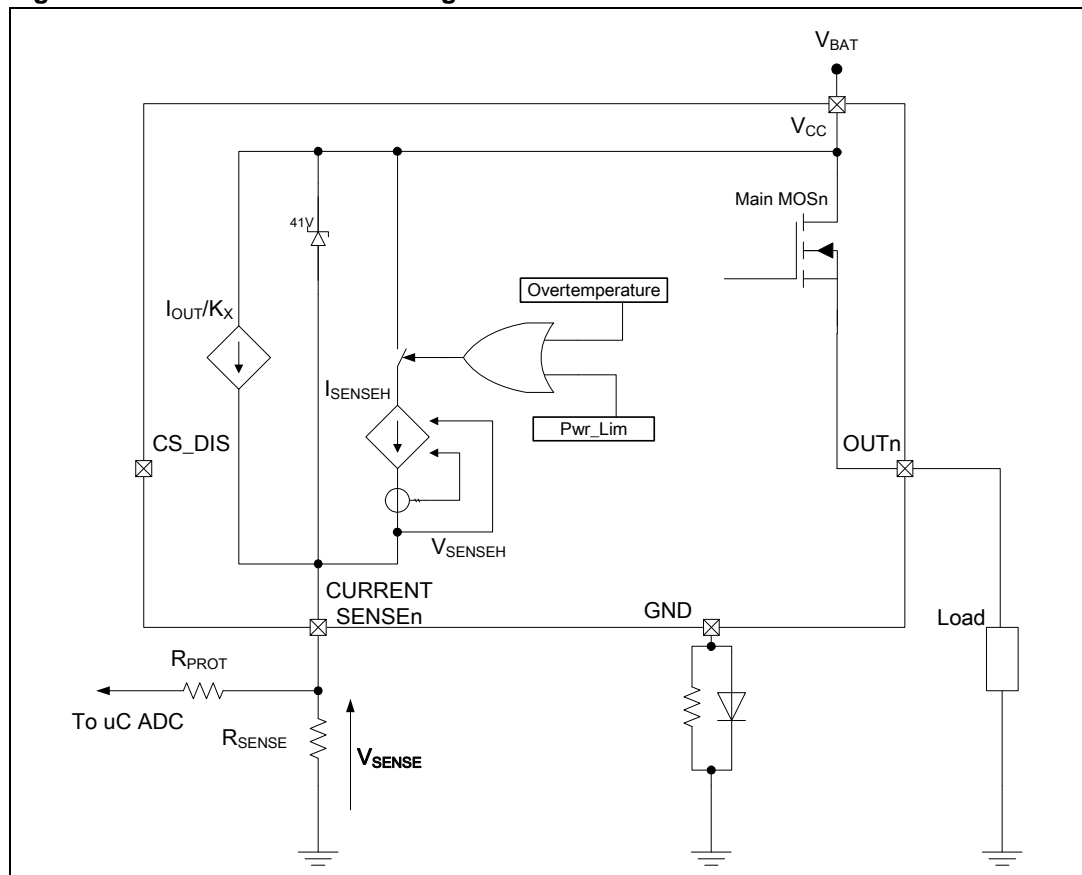

3.5 Maximum demagnetization energy ($V_{CC} = 13.5V$)

Figure 31. Maximum turn-off current versus inductance (for each channel)⁽¹⁾

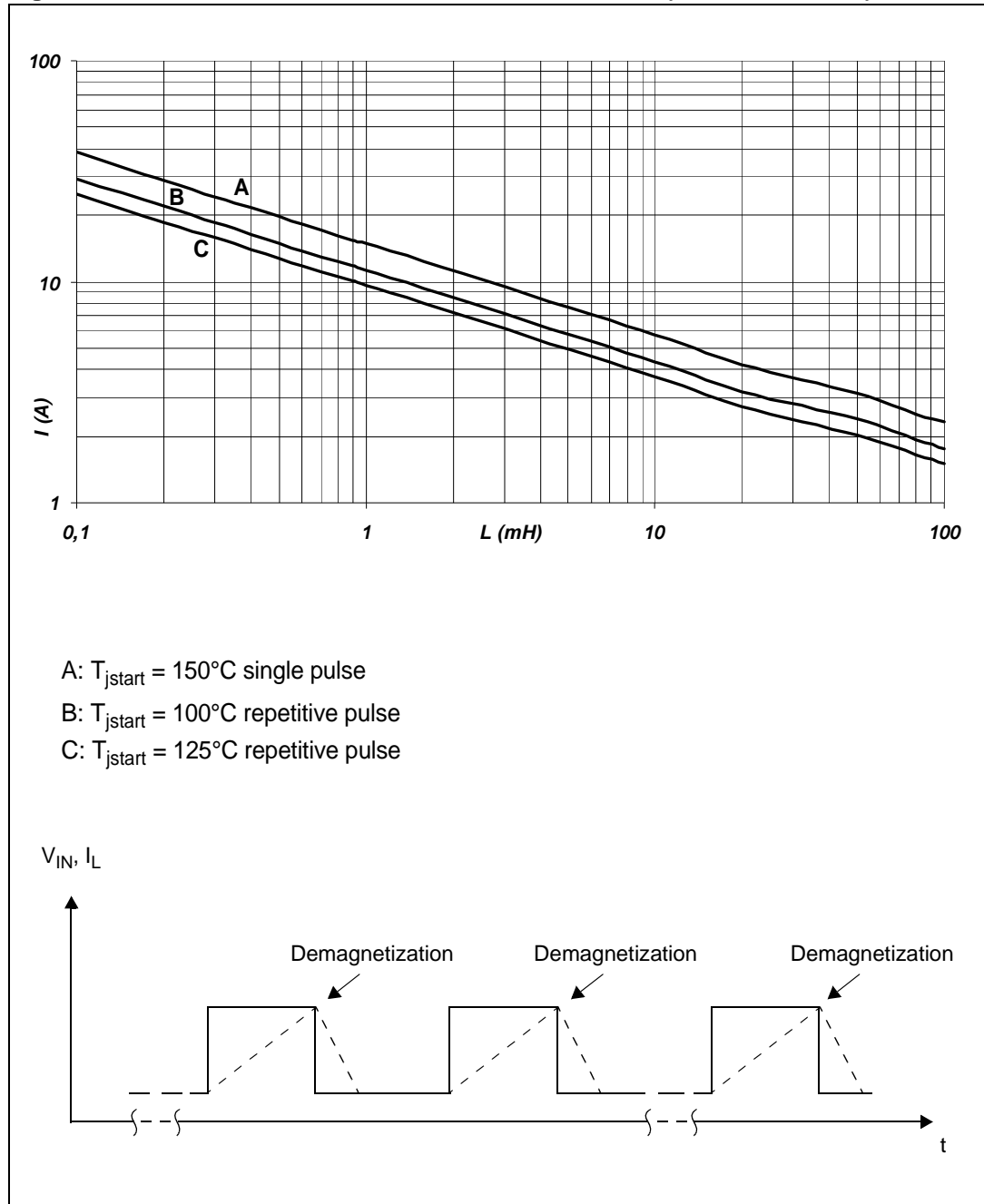

1. Values are generated with $R_{\theta} = 0 \Omega$.
 In case of repetitive pulses, T_{jstart} (at beginning of each demagnetization) of every pulse must not exceed the temperature specified above for curves A and B.

4 Package and thermal data

4.1 PowerSSO-24 thermal data

Figure 32. PowerSSO-24 PC board⁽¹⁾

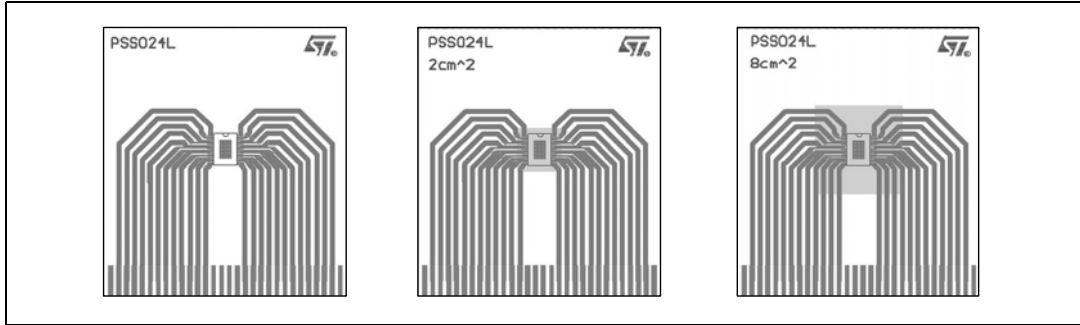

1. Layout condition of R_{th} and Z_{th} measurements (PCB: Double layer, Thermal Vias, FR4 area = 77mm x 86mm, PCB thickness = 1.6mm, Cu thickness = 70 μ m (front and back side), Copper areas: from minimum pad layout to 8cm²).

Figure 33. $R_{thj-amb}$ vs PCB copper area in open box free air condition (one channel ON)

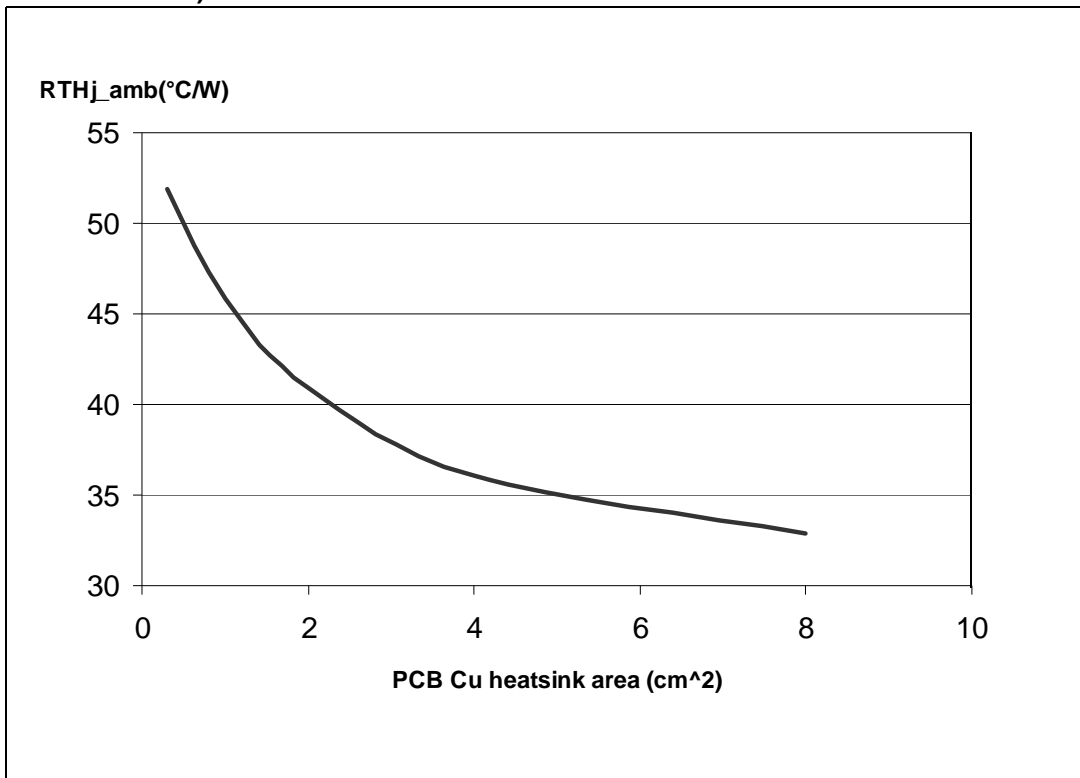
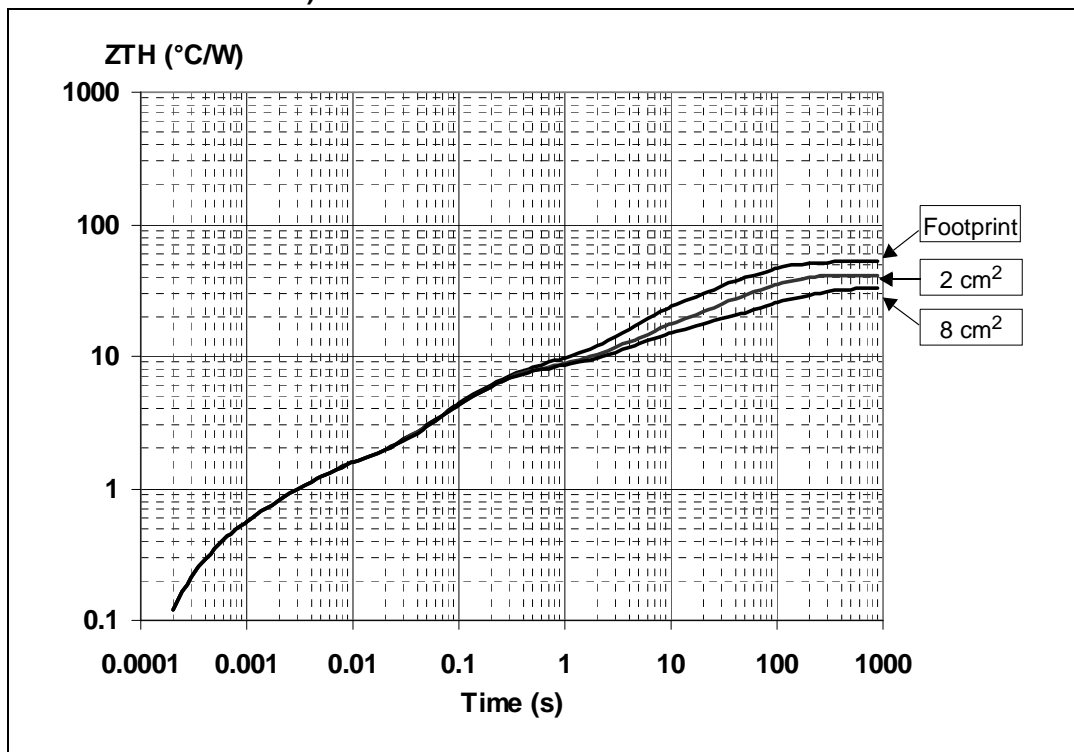

Figure 34. PowerSSO-24 thermal impedance junction to ambient single pulse (one channel ON)



Equation 1: pulse calculation formula

$$Z_{TH\delta} = R_{TH} \cdot \delta + Z_{THtp}(1 - \delta)$$

where $\delta = t_p/T$

Figure 35. Thermal fitting model of a double-channel HSD in PowerSSO-24⁽¹⁾

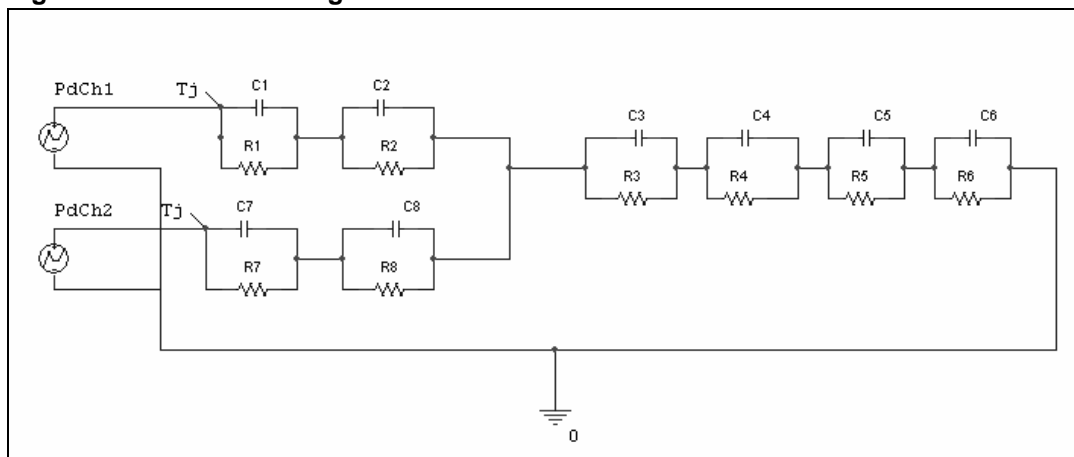

1. The fitting model is a simplified thermal tool and is valid for transient evolutions where the embedded protections (power limitation or thermal cycling during thermal shutdown) are not triggered.

Table 14. Thermal parameters

Area/Island (cm ²)	Footprint	2	8
R1 (°C/W)	0.28		
R2 (°C/W)	0.9		
R3 (°C/W)	6		
R4 (°C/W)	7.7		
R5 (°C/W)	9	9	8
R6 (°C/W)	28	17	10
R7 (°C/W)	0.28		
R8 (°C/W)	0.9		
C1 (W.s/°C)	0.001		
C2 (W.s/°C)	0.003		
C3 (W.s/°C)	0.025		
C4 (W.s/°C)	0.75		
C5 (W.s/°C)	1	4	9
C6 (W.s/°C)	2.2	5	17
C7 (W.s/°C)	0.001		
C8 (W.s/°C)	0.003		

5 Package and packing information

5.1 ECOPACK[®] packages

In order to meet environmental requirements, ST offers these devices in different grades of ECOPACK[®] packages, depending on their level of environmental compliance. ECOPACK[®] specifications, grade definitions and product status are available at: www.st.com.

ECOPACK[®] is an ST trademark.

5.2 Package mechanical data

Figure 36. PowerSSO-24 package dimensions

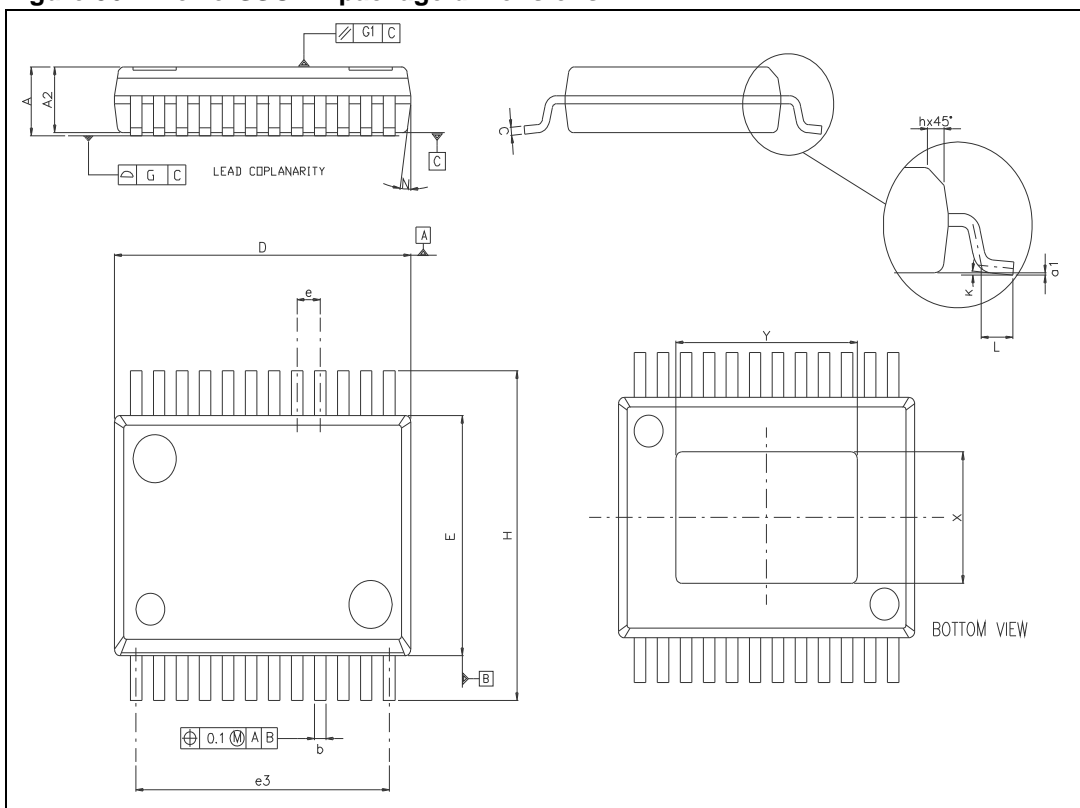

Table 15. PowerSSO-24 mechanical data

Symbol	Millimeters		
	Min.	Typ.	Max.
A	2.15		2.47
A2	2.15		2.40
a1	0		0.075
b	0.33		0.51
c	0.23		0.32
D	10.10		10.50
E	7.4		7.6
e		0.8	
e3		8.8	
G			0.1
G1			0.06
H	10.1		10.5
h			0.4
k		5°	
L	0.55		0.85
N			10°
X	4.1		4.7
Y	6.5		7.1

5.3 Packing information

Figure 37. PowerSSO-24 tube shipment (no suffix)

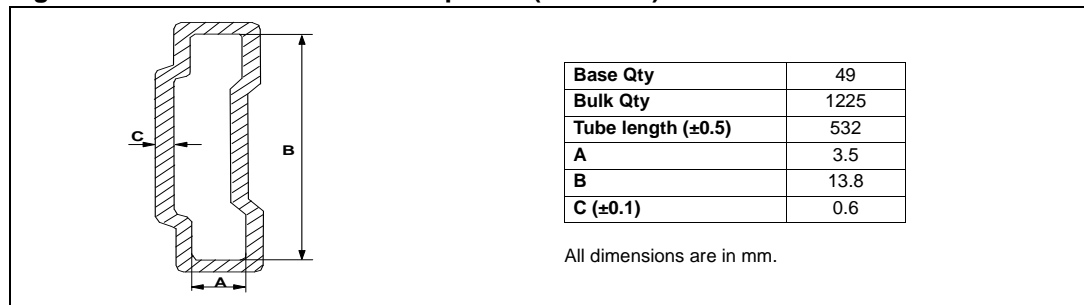
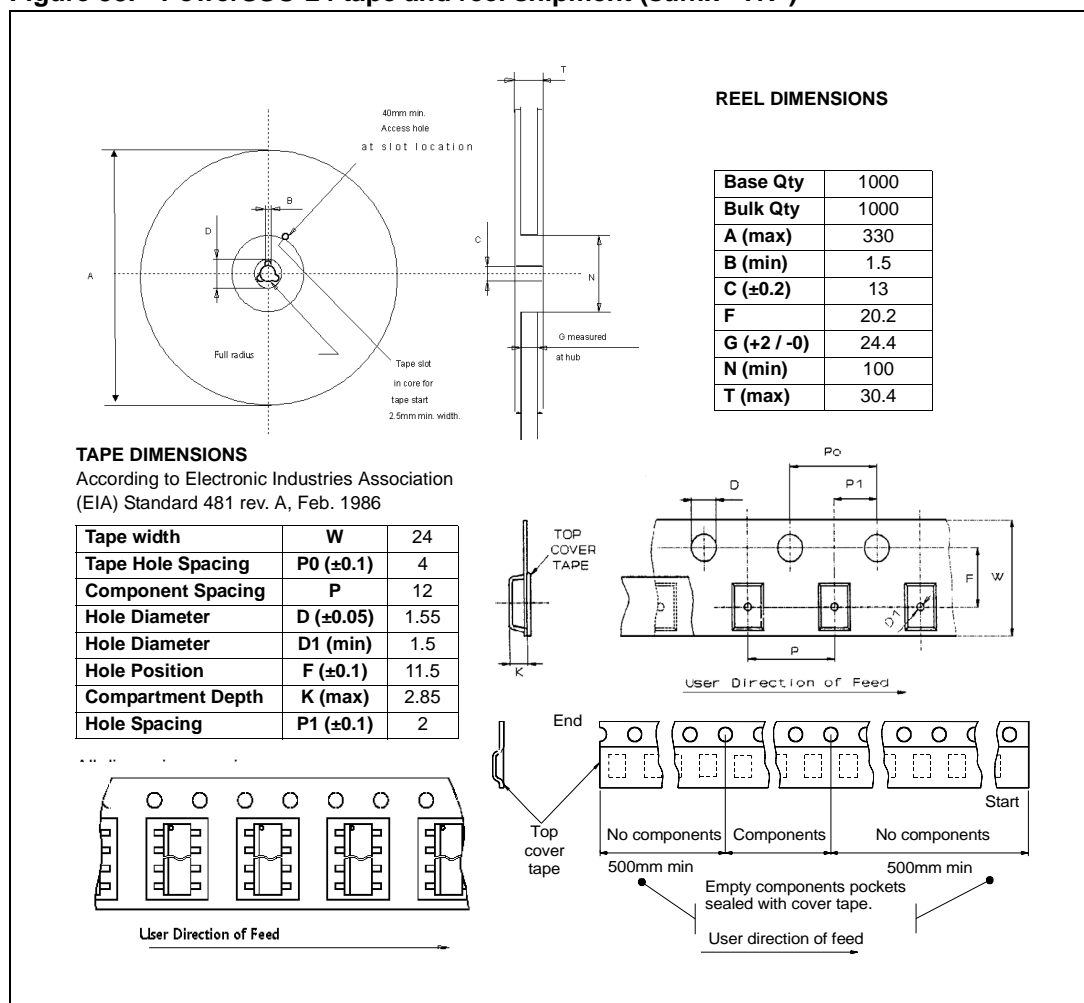

Figure 38. PowerSSO-24 tape and reel shipment (suffix "TR")



6 Order codes

Table 16. Device summary

Package	Order codes	
	Tube	Tape and reel
PowerSSO-24	VND5E025MK-E	VND5E025MKTR-E

7 Revision history

Table 17. Document revision history

Date	Revision	Changes
07-Oct-2009	1	Initial release
19-Sep-2013	2	Updated Disclaimer.

Please Read Carefully:

Information in this document is provided solely in connection with ST products. STMicroelectronics NV and its subsidiaries ("ST") reserve the right to make changes, corrections, modifications or improvements, to this document, and the products and services described herein at any time, without notice.

All ST products are sold pursuant to ST's terms and conditions of sale.

Purchasers are solely responsible for the choice, selection and use of the ST products and services described herein, and ST assumes no liability whatsoever relating to the choice, selection or use of the ST products and services described herein.

No license, express or implied, by estoppel or otherwise, to any intellectual property rights is granted under this document. If any part of this document refers to any third party products or services it shall not be deemed a license grant by ST for the use of such third party products or services, or any intellectual property contained therein or considered as a warranty covering the use in any manner whatsoever of such third party products or services or any intellectual property contained therein.

UNLESS OTHERWISE SET FORTH IN ST'S TERMS AND CONDITIONS OF SALE ST DISCLAIMS ANY EXPRESS OR IMPLIED WARRANTY WITH RESPECT TO THE USE AND/OR SALE OF ST PRODUCTS INCLUDING WITHOUT LIMITATION IMPLIED WARRANTIES OF MERCHANTABILITY, FITNESS FOR A PARTICULAR PURPOSE (AND THEIR EQUIVALENTS UNDER THE LAWS OF ANY JURISDICTION), OR INFRINGEMENT OF ANY PATENT, COPYRIGHT OR OTHER INTELLECTUAL PROPERTY RIGHT.

ST PRODUCTS ARE NOT DESIGNED OR AUTHORIZED FOR USE IN: (A) SAFETY CRITICAL APPLICATIONS SUCH AS LIFE SUPPORTING, ACTIVE IMPLANTED DEVICES OR SYSTEMS WITH PRODUCT FUNCTIONAL SAFETY REQUIREMENTS; (B) AERONAUTIC APPLICATIONS; (C) AUTOMOTIVE APPLICATIONS OR ENVIRONMENTS, AND/OR (D) AEROSPACE APPLICATIONS OR ENVIRONMENTS. WHERE ST PRODUCTS ARE NOT DESIGNED FOR SUCH USE, THE PURCHASER SHALL USE PRODUCTS AT PURCHASER'S SOLE RISK, EVEN IF ST HAS BEEN INFORMED IN WRITING OF SUCH USAGE, UNLESS A PRODUCT IS EXPRESSLY DESIGNATED BY ST AS BEING INTENDED FOR "AUTOMOTIVE, AUTOMOTIVE SAFETY OR MEDICAL" INDUSTRY DOMAINS ACCORDING TO ST PRODUCT DESIGN SPECIFICATIONS. PRODUCTS FORMALLY ESCC, QML OR JAN QUALIFIED ARE DEEMED SUITABLE FOR USE IN AEROSPACE BY THE CORRESPONDING GOVERNMENTAL AGENCY.

Resale of ST products with provisions different from the statements and/or technical features set forth in this document shall immediately void any warranty granted by ST for the ST product or service described herein and shall not create or extend in any manner whatsoever, any liability of ST.

ST and the ST logo are trademarks or registered trademarks of ST in various countries.

Information in this document supersedes and replaces all information previously supplied.

The ST logo is a registered trademark of STMicroelectronics. All other names are the property of their respective owners.

© 2013 STMicroelectronics - All rights reserved



STMicroelectronics group of companies

Australia - Belgium - Brazil - Canada - China - Czech Republic - Finland - France - Germany - Hong Kong - India - Israel - Italy - Japan - Malaysia - Malta - Morocco - Philippines - Singapore - Spain - Sweden - Switzerland - United Kingdom - United States of America

www.st.com

Looking for pricing, stock, or lifecycle information?

Click below to explore more details on WIN SOURCE:

-  [View VND5E025MK-E on WIN SOURCE](#)
-  [STMicroelectronics](#) Information

Optimize Your Supply Chain with WIN SOURCE Solutions

-  Global Sourcing Solution
-  Obsolete Management
-  Cost Control Management
-  Shortage Management
-  Alternative Solution
-  Excess Inventory Management