



**THE DATASHEET OF
CBT6832EDGG,112**



DATA SHEET

CBT6832E

16-bit controlled enable rate
1-of-2 multiplexer/demultiplexer with
precharged outputs and Schottky
undershoot protection for live insertion

Product specification
Supersedes data of 2000 May 19

2000 Sep 01

16-bit controlled enable rate 1-of-2 multiplexer/demultiplexer with precharged outputs and Schottky undershoot protection for live insertion

CBT6832E

FEATURES

- 5 Ω typical r_{on}
- Pull-up on B port
- Undershoot protection on A port only: -2.0 V
- Near zero propagation delay
- Controlled enable rate
- V_{CC} operating range: +4.5 V to +5.5 V
- > 100 MHz bandwidth (or clock rate) at 20 pF load capacitance
- 56-pin TSSOP package
- Bias voltage pre-charges the B output when the channel is disabled
- Latch-up protection exceeds 100 mA per JESD78
- ESD protection exceeds 2000 V HBM per JESD22-A114, 200 V MM per JESD22-A115 and 1000 V CDM per JESD22-C101

APPLICATION

- Provides PCI hot-plugging

DESCRIPTION

The CBT6832E is a 16-bit controlled enable rate 1-of-2 multiplexer/demultiplexer with precharged outputs and Schottky undershoot protection for live insertion. Advantages of the CBT6832 include a propagation delay of 250 ps, resulting from 5 Ω channel resistance, and low I/O capacitance. A port demultiplexes to either 1B and 2B, or to both. The switch is bi-directional.

PIN CONFIGURATION

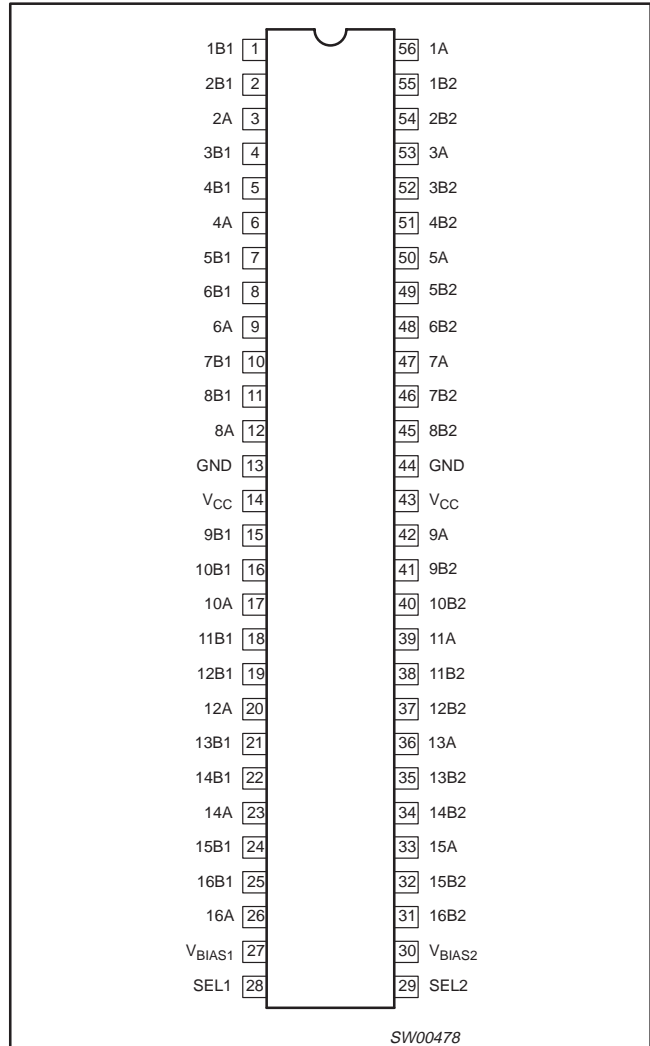

QUICK REFERENCE DATA

SYMBOL	PARAMETER	CONDITIONS $T_{amb} = 25^{\circ}C; GND = 0 V$	TYPICAL	UNIT
t_{PLH} t_{PHL}	Propagation delay An to Bn or Bn to An	$C_L = 50 pF; V_{CC} = 5 V$.25	ns
C_{IN}	Input capacitance control pins	$V_I = 0 V$ or V_{CC}	4.5	pF
$C_{OFF B}$	B capacitance, switch off	Outputs disabled; $V_O = 0 V$	8	pF
$C_{OFF A}$	A capacitance, switch off	Outputs disabled; $V_O = 0 V$	13	pF
$C_{ON 1}$	One channel enabled capacitance	One B enabled; $V_O = 0 V$	21	pF
$C_{ON 2}$	Both channels enabled capacitance	Both B channels enabled; $V_O = 0 V$	34	pF

ORDERING INFORMATION

PACKAGES	TEMPERATURE RANGE	ORDER CODE	DWG NUMBER
56-Pin Plastic TSSOP Type II	0°C to +70°C	CBT6832E DGG	SOT364-1

16-bit controlled enable rate 1-of-2 multiplexer/demultiplexer with precharged outputs and Schottky undershoot protection for live insertion

CBT6832E

PIN DESCRIPTION

PIN NUMBER	SYMBOL	NAME AND FUNCTION
3, 6, 9, 12, 17, 20, 23, 26, 33, 36, 39, 42, 47, 50, 53, 56	1A1–16A1	Inputs
1, 2, 4, 5, 7, 8, 10, 11, 15, 16, 18, 19, 21, 22, 24, 25	1B1–16B1	Outputs
31, 32, 34, 35, 37, 38, 40, 41, 45, 46, 48, 49, 51, 52, 54, 55	1B2–16B2	Outputs
27, 30	V_{BIAS1} , V_{BIAS2}	Precharge bias voltage inputs
28, 29	SEL1, SEL2	Select-control inputs
13, 44	GND	Ground (0 V)
14, 43	V_{CC}	Positive supply voltage

FUNCTION TABLE

SEL1	SEL2	FUNCTION
L	H	nA to nB1
H	L	nA to nB2
L	L	nA to nB1 and nB2
H	H	nB1, nB2 = V_{BIAS}

LOGIC DIAGRAM

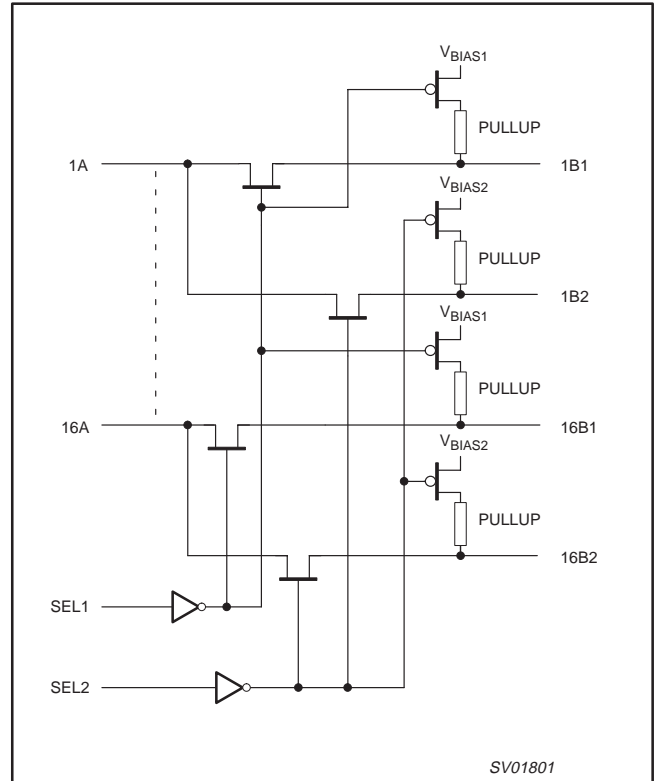

ABSOLUTE MAXIMUM RATINGS^{1, 2}

SYMBOL	PARAMETER	CONDITIONS	RATING	UNIT
V_{CC}	DC supply voltage		-0.5 to +7.0	V
I_{IK}	DC input diode current	$V_I < 0$	-50	mA
V_I	DC input voltage ³		-0.5 to +7.0	V
V_{OUT}	DC output voltage ³	output in Off or High state	-0.5 to +7.0	V
I_{OUT}	DC output current	output in Low state	120	mA
T_{stg}	Storage temperature range		-65 to +150	°C
θ_{JA}	Power dissipation		95	°C/W

NOTES:

- Stresses beyond those listed may cause permanent damage to the device. These are stress ratings only and functional operation of the device at these or any other conditions beyond those indicated under "recommended operating conditions" is not implied. Exposure to absolute-maximum-rated conditions for extended periods may affect device reliability.
- The performance capability of a high-performance integrated circuit in conjunction with its thermal environment can create junction temperatures which are detrimental to reliability. The maximum junction temperature of this integrated circuit should not exceed 150°C.
- The input and output voltage ratings may be exceeded if the input and output current ratings are observed.

RECOMMENDED OPERATING CONDITIONS

SYMBOL	PARAMETER	LIMITS		UNIT
		MIN	MAX	
V_{CC}	DC supply voltage	4.5	5.5	V
V_{IH}	High-level input voltage	2.0		V
V_{IL}	Low-level Input voltage		0.8	V
T_{amb}	Operating free-air temperature range	0	+70	°C

16-bit controlled enable rate 1-of-2 multiplexer/demultiplexer with precharged outputs and Schottky undershoot protection for live insertion

CBT6832E

DC ELECTRICAL CHARACTERISTICSOver operating temperature range $T_{amb} = 0^{\circ}\text{C}$ to $+70^{\circ}\text{C}$; $V_{CC} = 5\text{ V} \pm 10\%$; $V_{BIAS} = 1.3\text{ V}$ to V_{CC} , unless otherwise specified.

SYMBOL	PARAMETER	TEST CONDITIONS	LIMITS			UNIT
			MIN	TYP ¹	MAX	
V_{IH}	Input HIGH voltage	Guaranteed logic HIGH level	2.0			V
V_{IL}	Input LOW voltage	Guaranteed logic LOW level	-0.5		0.8	V
I_{IH}	Input HIGH current	$V_{CC} = 5.5\text{ V}$, $V_{IN} = V_{CC}$			± 5	μA
I_{IL}	Input LOW current	$V_{CC} = 5.5\text{ V}$, $V_{IN} = \text{GND}$			± 5	μA
I_{OZH}	High impedance output current	$A = 0\text{ V}$ or $V_{CC}\text{ MAX}$, $V_{BIAS1} = V_{BIAS2} = V_{CC}\text{ MAX}$			± 1	μA
I_{OZL}	Low impedance output current	$B = 0\text{ V}$ or $V_{CC}\text{ MAX}$, $V_{BIAS1} = V_{BIAS2} = V_{CC}\text{ MAX}$	-0.2		-2	mA
V_{IK}	Input clamp voltage	$V_{CC} = 4.5\text{ V}$; $I_I = -18\text{ mA}$		-0.7	-1.8	V
r_{on}	Switch on resistance ²	$V_{CC} = 4.5\text{ V}$; $V_I = 0\text{ V}$; $I_I = 48\text{ mA}$		5	8	Ω
		$V_{CC} = 4.5\text{ V}$; $V_I = 2.4\text{ V}$; $I_I = -15\text{ mA}$		10	15	Ω
Capacitance³ ($T_{amb} = +25^{\circ}\text{C}$; $f = 1\text{ MHz}$)						
C_{IN}	Input capacitance	$V_I = 0\text{ V}$		4.5		pF
$C_{OFF\ B}$	B capacitance, switch off	$V_I = 0\text{ V}$		8		pF
$C_{OFF\ A}$	A capacitance, switch off	$V_I = 0\text{ V}$		13		pF
$C_{ON\ 1}$	Capacitance, switch on (one B)	$V_I = 0\text{ V}$		21		pF
$C_{ON\ 2}$	Capacitance, both B channels enabled	$V_I = 0\text{ V}$		34		pF
Power supply						
I_{CC}	Quiescent supply current enabled	$V_{CC} = 5.5\text{ V}$; $V_I = V_{CC}$ or GND			100	μA
ΔI_{CC}	Additional supply current per input pin ⁵	$V_{CC} = 5.5\text{ V}$, one input at 3.4 V , other inputs at V_{CC} or GND			2.5	mA

NOTES:

- All typical values are at $V_{CC} = 5\text{ V}$, $T_{amb} = +25^{\circ}\text{C}$ ambient and maximum loading.
- Measured by the voltage drop between the A and the B terminals at the indicated current through the switch. On-state resistance is determined by the lowest voltage of the two (A or B) terminals.
- These parameters are determined by device characterization, but is not production tested.
- Not more than one output should be shorted at one time. Duration of the test should not exceed one second.
- Per TTL driven input ($V_I = 3.4\text{ V}$, control inputs only); A and B pins do not contribute to I_{CC} .
- This current applies to the control inputs only and represent the current required to switch internal capacitance at the specified frequency. The A and B inputs generate no significant AC or DC currents as they transition. this parameter is not tested, but is guaranteed by design.

16-bit controlled enable rate 1-of-2 multiplexer/demultiplexer with precharged outputs and Schottky undershoot protection for live insertion

CBT6832E

AC CHARACTERISTICS

$V_{CC} = 5.0\text{ V} \pm 0.5\text{ V}$; $GND = 0\text{ V}$; $C_L = 50\text{ pF}$, $R_L = 500\ \Omega$

SYMBOL	PARAMETER	TEST CONDITIONS	LIMITS			UNIT
			MIN	TYP	MAX	
t_{PLH} t_{PHL}	Propagation delay ¹ A to B	Waveform 1		0.25		ns
t_{PZH} t_{PZL}	Bus enable time SEL to A, B	Waveform 2	10 5		30 25	ns
t_{PHZ} t_{PLZ}	Bus disable time SEL to A, B	Waveform 2	0.5 0.5		6 7	ns

NOTE:

1. This parameter is warranted but not production tested. The propagation delay is based on the RC time constant of the typical on-state resistance of the switch and a load capacitance of 50 pF, when driven by an ideal voltage source (zero output impedance).

AC WAVEFORMS

$V_M = 1.5\text{ V}$, $V_{IN} = GND\text{ to }3.0\text{ V}$

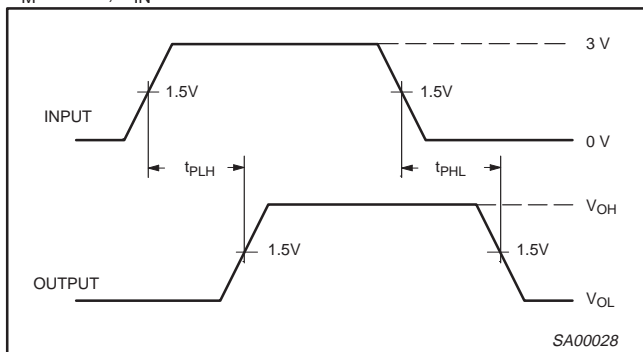

Waveform 1. Input (An) to Output (Bn) Propagation Delays

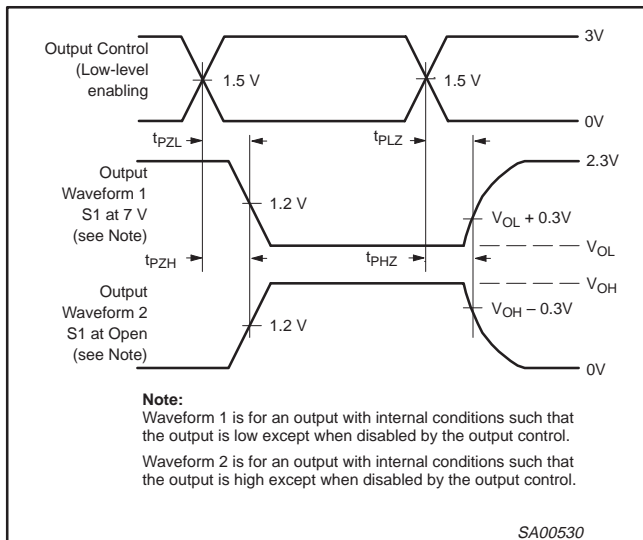

Note:
Waveform 1 is for an output with internal conditions such that the output is low except when disabled by the output control.
Waveform 2 is for an output with internal conditions such that the output is high except when disabled by the output control.

Waveform 2. 3-State Output Enable and Disable Times

TEST CIRCUIT AND WAVEFORMS

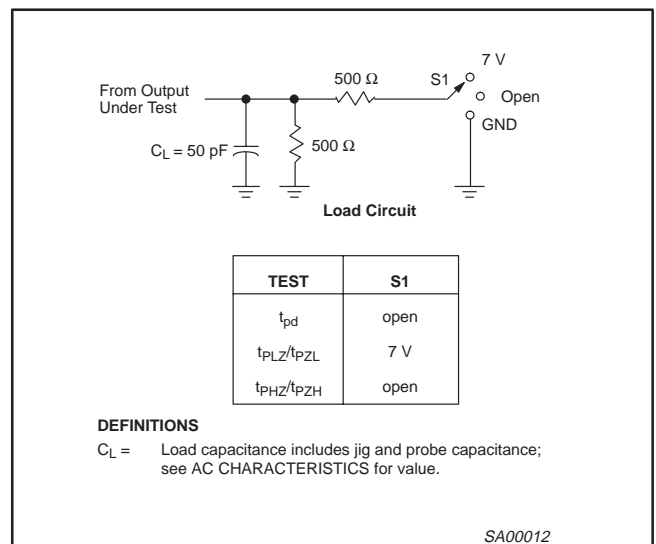

16-bit controlled enable rate 1-of-2 multiplexer/demultiplexer with precharged outputs and Schottky undershoot protection for live insertion

CBT6832E

TSSOP56: plastic thin shrink small outline package; 56 leads; body width 6.1 mm

SOT364-1

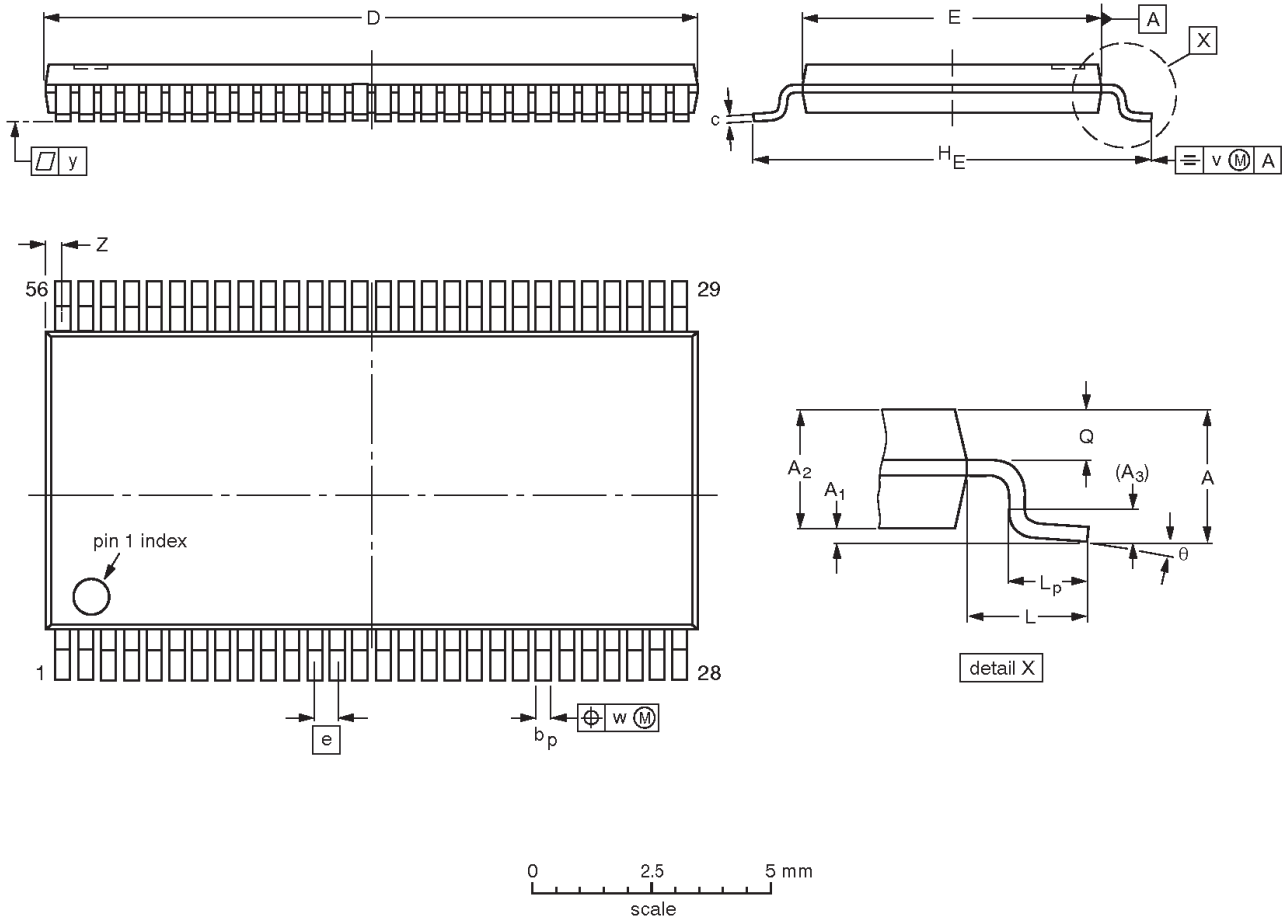

DIMENSIONS (mm are the original dimensions).

UNIT	A max.	A ₁	A ₂	A ₃	b _p	c	D ⁽¹⁾	E ⁽²⁾	e	H _E	L	L _p	Q	v	w	y	Z	θ
mm	1.2	0.15 0.05	1.05 0.85	0.25	0.28 0.17	0.2 0.1	14.1 13.9	6.2 6.0	0.5	8.3 7.9	1.0	0.8 0.4	0.50 0.35	0.25	0.08	0.1	0.5 0.1	8° 0°

Notes

1. Plastic or metal protrusions of 0.15 mm maximum per side are not included.
2. Plastic interlead protrusions of 0.25 mm maximum per side are not included.

OUTLINE VERSION	REFERENCES				EUROPEAN PROJECTION	ISSUE DATE
	IEC	JEDEC	EIAJ			
SOT364-1		MO-153				95-02-10 99-12-27

16-bit controlled enable rate 1-of-2 multiplexer/demultiplexer with precharged outputs and Schottky undershoot protection for live insertion

CBT6832E

NOTES

16-bit controlled enable rate 1-of-2 multiplexer/demultiplexer with precharged outputs and Schottky undershoot protection for live insertion

CBT6832E

Data sheet status

Data sheet status	Product status	Definition [1]
Objective specification	Development	This data sheet contains the design target or goal specifications for product development. Specification may change in any manner without notice.
Preliminary specification	Qualification	This data sheet contains preliminary data, and supplementary data will be published at a later date. Philips Semiconductors reserves the right to make changes at any time without notice in order to improve design and supply the best possible product.
Product specification	Production	This data sheet contains final specifications. Philips Semiconductors reserves the right to make changes at any time without notice in order to improve design and supply the best possible product.

[1] Please consult the most recently issued datasheet before initiating or completing a design.

Definitions

Short-form specification — The data in a short-form specification is extracted from a full data sheet with the same type number and title. For detailed information see the relevant data sheet or data handbook.

Limiting values definition — Limiting values given are in accordance with the Absolute Maximum Rating System (IEC 134). Stress above one or more of the limiting values may cause permanent damage to the device. These are stress ratings only and operation of the device at these or at any other conditions above those given in the Characteristics sections of the specification is not implied. Exposure to limiting values for extended periods may affect device reliability.

Application information — Applications that are described herein for any of these products are for illustrative purposes only. Philips Semiconductors make no representation or warranty that such applications will be suitable for the specified use without further testing or modification.

Disclaimers

Life support — These products are not designed for use in life support appliances, devices or systems where malfunction of these products can reasonably be expected to result in personal injury. Philips Semiconductors customers using or selling these products for use in such applications do so at their own risk and agree to fully indemnify Philips Semiconductors for any damages resulting from such application.

Right to make changes — Philips Semiconductors reserves the right to make changes, without notice, in the products, including circuits, standard cells, and/or software, described or contained herein in order to improve design and/or performance. Philips Semiconductors assumes no responsibility or liability for the use of any of these products, conveys no license or title under any patent, copyright, or mask work right to these products, and makes no representations or warranties that these products are free from patent, copyright, or mask work right infringement, unless otherwise specified.

Philips Semiconductors
811 East Arques Avenue
P.O. Box 3409
Sunnyvale, California 94088-3409
Telephone 800-234-7381

© Copyright Philips Electronics North America Corporation 2000
All rights reserved. Printed in U.S.A.

Date of release: 09-00

Document order number:

9397 750 07485

Let's make things better.

Looking for pricing, stock, or lifecycle information?

Click below to explore more details on WIN SOURCE:

 [View CBT6832EDGG,112 on WIN SOURCE](#)

 [NXP / Nexperia Information](#)

Optimize Your Supply Chain with WIN SOURCE Solutions

-  Global Sourcing Solution
-  Obsolete Management
-  Cost Control Management
-  Shortage Management
-  Alternative Solution
-  Excess Inventory Management