



# 3.3V/5V 2.5GHz PECL/ECL 1:4 FANOUT BUFFER WITH 2:1 INPUT MUX

ECL Pro™  
SY100EP15V

## FEATURES

- High-speed 1:4 PECL/ECL fanout buffer
- 2:1 multiplexer input
- Guaranteed AC parameters over temp/voltage:
  - > 2.5GHz  $f_{MAX}$  (toggle)
  - < 225ps rise/fall times
  - < 25ps within device skew
  - < 425ps propagation delay (CLK-to-Q)
- Low jitter design:
  - < 1ps<sub>RMS</sub> cycle-to-cycle jitter
  - < 20ps<sub>PP</sub> total jitter
- Flexible power supply: 3.3V/5V
- Wide operating temperature range: -40°C to +85°C
- $V_{BB}$  reference for AC-coupled or single-ended applications
- Output enable/disable function
- 100K PECL/ECL compatible logic
- Input accepts PECL/LVPECL/ECL/HSTL logic levels
- Available in a 16-pin TSSOP package

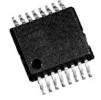

ECL Pro™

## DESCRIPTION

The SY100EP15V is a high-speed, low-skew, PECL/ECL 1:4 precision fanout buffer with a 2:1 mux front end in a small 16-pin TSSOP package. The 2:1 mux input accepts a single-ended PECL/ECL source (CLK1) and a differential PECL/ECL/HSTL source (CLK0). All I/O pins are 100K EP PECL/ECL logic compatible.

AC performance is guaranteed over the industrial -40°C to +85°C temperature range and 3.3V to 5V supply voltage. This device will operate in PECL/LVPECL or ECL/LVECL mode. For clock applications, the high-speed design combined with an extremely fast rise/fall time of less than 225ps produces a toggle frequency as high as 2.5GHz (~400mV<sub>PP</sub> swing).

A  $V_{BB}$  output reference pin is available for AC-coupled and single-ended input applications. In addition, a synchronous output enable function is provided.

The SY100EP15V is part of Micrel's high-speed, precision edge timing and distribution family. For applications that require a different I/O combination, consult Micrel's website at [www.micrel.com](http://www.micrel.com), and choose from a comprehensive product line of high-speed, low-skew fanout buffers, translators, and clock dividers.

All support documentation can be found on Micrel's web site at: [www.micrel.com](http://www.micrel.com).

**PACKAGE/ORDERING INFORMATION**

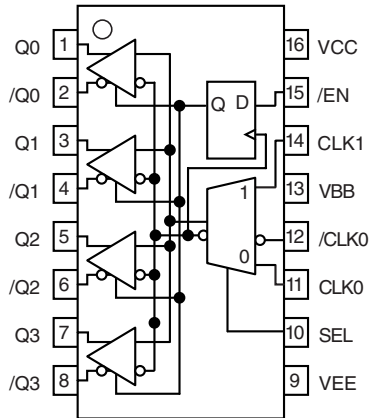

**Available in 16-Pin TSSOP  
(K4-16-1)**

**Ordering Information<sup>(1)</sup>**

Part Number	Package Type	Operating Range	Package Marking	Lead Finish
SY100EP15VK4C	K4-16-1	Commercial	XEP15V	Sn-Pb
SY100EP15VK4CTR <sup>(2)</sup>	K4-16-1	Commercial	XEP15V	Sn-Pb
SY100EP15VK4I	K4-16-1	Industrial	XEP15V	Sn-Pb
SY100EP15VK4ITR <sup>(2)</sup>	K4-16-1	Industrial	XEP15V	Sn-Pb
SY100EP15VK4G <sup>(3)</sup>	K4-16-1	Industrial	XEP15V with Pb-Free bar-line Indicator	NiPdAu Pb-Free
SY100EP15VK4GTR <sup>(2, 3)</sup>	K4-16-1	Industrial	XEP15V with Pb-Free bar-line Indicator	NiPdAu Pb-Free

**Notes:**

1. Contact factory for die availability. Dice are guaranteed at T<sub>A</sub> = 25°C, DC Electricals only.
2. Tape and Reel.
3. Pb-Free package is recommended for new designs.

**PIN DESCRIPTION**

Pin	Pin Number	Function
1, 2, 3, 4 5, 6, 7, 8	Q0 – Q3 /Q0 – /Q3	Outputs 0 through 3: 100KEP (LV)PECL/(LV)ECL compatible differential outputs. Terminate with 50Ω to $V_{CC}-2V$ . Unused output pairs may be left floating, or pulled-down with a 2kΩ resistor to the most negative supply. Unused single-ended outputs must have a balanced load. For AC-coupled applications, the output stage emitter follower must have a DC current path to ground. See “Termination” section.
9	VEE	Negative Power Supply: For PECL/LVPECL applications, connect to GND.
10	SEL	100KEP (LV)PECL/(LV)ECL Compatible 2:1 Mux Input Select Control. See “Truth Table.” The select (SEL) pin includes an internal 75kΩ pull-down resistor. Default condition when left floating is LOW, and CLK0 input is selected.
11, 12	CLK0, /CLK0	Differential (LV)PECL/(LV)ECL/HSTL Compatible Input: The inputs include an internal 75kΩ pull-down resistor on CLK0 and internal 75kΩ pull-up and pull-down on /CLK0. Default condition for CLK0 is LOW when left floating and $V_{CC}/2$ for /CLK0 when left floating.
13	VBB	Reference Output Voltage: This reference is typically used to bias the unused inverting input for single-ended input applications, or as the termination point for AC-coupled differential input applications. $V_{BB}$ reference value is approximately $V_{CC}-1.3V$ , and tracks $V_{CC}$ 1:1. Maximum sink/source capability for $V_{BB}$ is 0.50mA. For single ended inputs, connect to the unused input through a 50Ω resistor. Decouple the $V_{BB}$ pin with a 0.01μF capacitor to $V_{CC}$ .
14	CLK1	Single-Ended (LV)PECL/(LV)ECL Compatible Input: This pin includes an internal 75kΩ pull-down resistor. Default condition is LOW when left floating.
15	/EN	100KEP (LV)PECL/(LV)ECL Compatible Input: This synchronous pin controls the output state. See “Truth Table.” To ensure proper synchronous operation, adhere to the Set-up and Hold times, as described in the AC electrical table. When /EN pin goes HIGH, Q outputs go LOW, and /Q outputs go HIGH on the next falling clock transition. This synchronous operation avoids any chance of generating a runt pulse.
16	VCC	Positive Power Supply: Bypass with 0.1μF//0.01μF low ESR capacitors.

**TRUTH TABLE<sup>(1)</sup>**

CLK0	CLK1	SEL	/EN	Q
L	X	L	L	L
H	X	L	L	H
X	L	H	L	L
X	H	H	L	H
$\bar{L}$	X	L	H	L
X	$\bar{L}$	H	H	L

**Note:**

- $\bar{L}$  = Negative edge.

**ABSOLUTE MAXIMUM RATINGS<sup>(1)</sup>**

Symbol	Rating	Value	Unit
$V_{CC} - V_{EE}$	Power Supply Voltage	6.0	V
$V_{IN}$	Input Voltage ( $V_{CC} = 0V$ , $V_{IN}$ not more negative than $V_{EE}$ ) Input Voltage ( $V_{EE} = 0V$ , $V_{IN}$ not more positive than $V_{CC}$ )	-6.0 to 0 +6.0 to 0	V
$I_{OUT}$	Output Current -Continuous -Surge	50 100	mA
$I_{BB}$	$V_{BB}$ Sink/Source Current <sup>(2)</sup>	±0.5	mA
$T_{LEAD}$	Lead Temperature (soldering, 20sec.)	+260	°C
$T_A$	Operating Temperature Range	-40 to +85	°C
$T_{STORE}$	Storage Temperature Range	-65 to +150	°C
$\theta_{JA}$	Package Thermal Resistance (Junction-to-Ambient) -Still-Air (single-layer PCB) -Still-Air (multi-layer PCB) -500lfpm (multi-layer PCB)	115 75 65	°C/W
$\theta_{JC}$	Package Thermal Resistance (Junction-to-Case)	21	°C/W

**Notes:**

1. Permanent device damage may occur if absolute maximum ratings are exceeded. This is a stress rating only and functional operation is not implied at conditions other than those detailed in the operational sections of this data sheet. Exposure to absolute maximum rating conditions for extended periods may affect device reliability.
2. Due to the limited drive capability, use for inputs of same package only.

**DC ELECTRICAL CHARACTERISTICS<sup>(1)</sup>**

Symbol	Parameter	$T_A = -40^\circ\text{C}$			$T_A = +25^\circ\text{C}$			$T_A = +85^\circ\text{C}$			Unit	Condition
		Min.	Typ.	Max.	Min.	Typ.	Max.	Min.	Typ.	Max.		
$V_{CC}$	Power Supply Voltage (PECL) (LVPECL) (ECL) (LVECL)	4.5 2.97 -5.5 -3.63	5.0 3.3 -5.0 -3.3	5.5 3.63 -4.5 -2.97	4.5 2.97 -5.5 -3.63	5.0 3.3 -5.0 -3.3	5.5 3.63 -4.5 -2.97	4.5 2.97 -5.5 -3.63	5.0 3.3 -5.0 -3.3	5.5 3.63 -4.5 -2.97	V	
$I_{CC}$	Power Supply Current	—	—	70	—	52	72	—	—	75	mA	
$I_{IH}$	Input HIGH Current	—	—	150	—	—	150	—	—	150	μA	$V_{IN} = V_{IH}$
$I_{IL}$	Input LOW Current CLK0, CLK1 /CLK0	0.5 -150	— —	— —	0.5 -150	— —	— —	0.5 -150	— —	— —	μA μA	$V_{IN} = V_{IL}$ $V_{IN} = V_{IL}$
$C_{IN}$	Input Capacitance (TSSOP)	—	—	—	—	1.0	—	—	—	—	pF	

**Note:**

1. 100KEP circuits are designed to meet the DC specifications shown in the above table after thermal equilibrium has been established. The circuit is in a test socket or mounted on a printed circuit board and traverse airflow greater than 500lfpm is maintained.

**(100KEP) LVPECL DC ELECTRICAL CHARACTERISTICS<sup>(1)</sup>** $V_{CC} = 3.0V \pm 10\%$ ,  $V_{EE} = 0V$ 

Symbol	Parameter	$T_A = -40^\circ\text{C}$			$T_A = +25^\circ\text{C}$			$T_A = +85^\circ\text{C}$			Unit	Condition
		Min.	Typ.	Max.	Min.	Typ.	Max.	Min.	Typ.	Max.		
$V_{IL}$	Input LOW Voltage (Single-Ended)	1355	—	1675	1355	—	1675	1355	—	1675	mV	$V_{CC} = 3.3V$
$V_{IH}$	Input HIGH Voltage (Single-Ended)	2075	—	2420	2075	—	2420	2075	—	2420	mV	$V_{CC} = 3.3V$
$V_{OL}$	Output LOW Voltage	1355	1480	1605	1355	1480	1605	1355	1480	1605	mV	$V_{CC} = 3.3V$
$V_{OH}$	Output HIGH Voltage	2155	2280	2405	2155	2280	2405	2155	2280	2405	mV	$V_{CC} = 3.3V$
$V_{BB}$	Reference Voltage <sup>(2)</sup>	1775	1875	1975	1775	1875	1975	1775	1875	1975	mV	$V_{CC} = 3.3V$
$V_{IHCMR}$	Input HIGH Voltage Common Mode Range <sup>(3)</sup>	1.2	—	$V_{CC}$	1.2	—	$V_{CC}$	1.2	—	$V_{CC}$	V	

**Notes:**

- 100KEP circuits are designed to meet the DC specifications shown in the above table after thermal equilibrium has been established. The circuit is in a test socket or mounted on a printed circuit board and traverse airflow greater than 500fpm is maintained. Input and output parameters varies 1:1 with  $V_{CC}$ . Output load is  $50\Omega$  to  $V_{CC}-2V$ .
- $V_{BB}$  varies 1:1 with  $V_{CC}$ .
- The  $V_{IHCMR}$  range is referenced to the most positive side of the differential input signal.

**(100KEP) PECL DC ELECTRICAL CHARACTERISTICS<sup>(1)</sup>** $V_{CC} = 5.0V \pm 10\%$ ,  $V_{EE} = 0V$ 

Symbol	Parameter	$T_A = -40^\circ\text{C}$			$T_A = +25^\circ\text{C}$			$T_A = +85^\circ\text{C}$			Unit	Condition
		Min.	Typ.	Max.	Min.	Typ.	Max.	Min.	Typ.	Max.		
$V_{IL}$	Input LOW Voltage (Single-Ended)	3055	—	3375	3055	—	3375	3055	—	3375	mV	$V_{CC} = 5V$
$V_{IH}$	Input HIGH Voltage (Single-Ended)	3775	—	4120	3775	—	4120	3775	—	4120	mV	$V_{CC} = 5V$
$V_{OL}$	Output LOW Voltage	3055	3180	3305	3055	3180	3305	3055	3180	3305	mV	$V_{CC} = 5V$
$V_{OH}$	Output HIGH Voltage	3855	3980	4105	3855	3980	4105	3855	3980	4105	mV	$V_{CC} = 5V$
$V_{BB}$	Output Voltage Reference <sup>(2)</sup>	3475	3575	3675	3475	3575	3675	3475	3575	3675	mV	$V_{CC} = 5V$
$V_{IHCMR}$	Input HIGH Voltage <sup>(3)</sup> Common Mode Range	1.2	—	$V_{CC}$	1.2	—	$V_{CC}$	1.2	—	$V_{CC}$	V	

**Notes:**

- 100KEP circuits are designed to meet the DC specifications shown in the above table after thermal equilibrium has been established. The circuit is in a test socket or mounted on a printed circuit board and traverse airflow greater than 500fpm is maintained. Input and output parameters varies 1:1 with  $V_{CC}$ . Output load is  $50\Omega$  to  $V_{CC}-2V$ .
- $V_{BB}$  varies 1:1 with  $V_{CC}$ .
- The  $V_{IHCMR}$  range is referenced to the most positive side of the differential input signal.

**(100KEP) LVECL DC ELECTRICAL CHARACTERISTICS<sup>(1)</sup>** $V_{CC} = 0V$ ,  $V_{EE} = -2.97V$  to  $-3.63V$ 

Symbol	Parameter	$T_A = -40^\circ C$			$T_A = +25^\circ C$			$T_A = +85^\circ C$			Unit	Condition
		Min.	Typ.	Max.	Min.	Typ.	Max.	Min.	Typ.	Max.		
$V_{IL}$	Input LOW Voltage (Single-ended)	-1945	—	-1625	-1945	—	-1625	-1945	—	-1625	mV	
$V_{IH}$	Input HIGH Voltage (Single-ended)	-1165	—	-880	-1165	—	-880	-1165	—	-880	mV	
$V_{OL}$	Output LOW Voltage	-1945	-1820	-1695	-1945	-1820	-1695	-1945	-1820	-1695	mV	$50\Omega$ to $V_{CC}-2V$
$V_{OH}$	Output HIGH Voltage	-1145	-1020	-895	-1145	-1020	-895	-1145	-1020	-895	mV	$50\Omega$ to $V_{CC}-2V$
$V_{BB}$	Output Reference Voltage	-1525	-1425	-1325	-1525	-1425	-1325	-1525	-1425	-1325	mV	
$V_{IHCMR}$	Input HIGH Voltage Common Mode Range <sup>(2)</sup>	$V_{EE}+1.2$	—	0.0	$V_{EE}+1.2$	—	0.0	$V_{EE}+1.2$	—	0.0	V	

**Notes:**

- 100KEP circuits are designed to meet the DC specifications shown in the above table after thermal equilibrium has been established. The circuit is in a test socket or mounted on a printed circuit board and traverse airflow greater than 500lfpm is maintained.
- The  $V_{IHCMR}$  range is referenced to the most positive side of the differential input signal.

**(100K) ECL DC ELECTRICAL CHARACTERISTICS<sup>(1)</sup>** $V_{CC} = 0V$ ,  $V_{EE} = -4.5V$  to  $-5.5V$ 

Symbol	Parameter	$T_A = -40^\circ C$			$T_A = +25^\circ C$			$T_A = +85^\circ C$			Unit	Condition
		Min.	Typ.	Max.	Min.	Typ.	Max.	Min.	Typ.	Max.		
$V_{IL}$	Input LOW Voltage	-1945	—	-1625	-1945	—	-1625	-1945	—	-1625	mV	
$V_{IH}$	Input HIGH Voltage	-1225	—	-880	-1225	—	-880	-1225	—	-880	mV	
$V_{OL}$	Output LOW Voltage	-1945	-1820	-1695	-1945	-1820	-1695	-1945	-1820	-1695	mV	$50\Omega$ to $V_{CC}-2V$
$V_{OH}$	Output HIGH Voltage	-1145	-1020	-895	-1145	-1020	-895	-1145	-1020	-895	mV	$50\Omega$ to $V_{CC}-2V$
$V_{BB}$	Output Reference Voltage	-1525	-1425	-1325	-1525	-1425	-1325	-1525	-1425	-1325	mV	
$V_{IHCMR}$	Input HIGH Voltage Common Mode Range <sup>(2)</sup>	$V_{EE}+1.2$	—	0.0	$V_{EE}+1.2$	—	0.0	$V_{EE}+1.2$	—	0.0	V	

**Notes:**

- 100KEP circuits are designed to meet the DC specifications shown in the above table after thermal equilibrium has been established. The circuit is in a test socket or mounted on a printed circuit board and traverse airflow greater than 500lfpm is maintained.
- The  $V_{IHCMR}$  range is referenced to the most positive side of the differential input signal.

**HSTL INPUT DC ELECTRICAL CHARACTERISTICS** $V_{CC} = 2.97V$  to  $3.63V$ ,  $V_{EE} = 0V$ 

Symbol	Parameter	$T_A = -40^\circ C$			$T_A = +25^\circ C$			$T_A = +85^\circ C$			Unit
		Min.	Typ.	Max.	Min.	Typ.	Max.	Min.	Typ.	Max.	
$V_{IH}$	Input HIGH Voltage	1200	—	—	1200	—	—	1200	—	—	mV
$V_{IL}$	Input LOW Voltage	—	—	400	—	—	400	—	—	400	mV

## AC ELECTRICAL CHARACTERISTICS

LVPECL:  $V_{CC} = 2.97V$  to  $3.63V$ ,  $V_{EE} = 0V$ ; PECL:  $V_{CC} = 4.5V$  to  $5.5V$ ,  $V_{EE} = 0V$

ECL:  $V_{CC} = 0V$ ,  $V_{EE} = -4.5V$  to  $-5.5V$ ; LVECL:  $V_{CC} = 0V$ ,  $V_{EE} = -2.97V$  to  $-3.63V$

Symbol	Parameter	$T_A = -40^\circ C$			$T_A = +25^\circ C$			$T_A = +85^\circ C$			Unit
		Min.	Typ.	Max.	Min.	Typ.	Max.	Min.	Typ.	Max.	
$f_{MAX}^{(1)}$	Maximum Frequency	2.5	—	—	2.5	—	—	2.5	—	—	GHz
$t_{PD}$	Propagation Delay to Output PECL/ECL										
	Diff. IN-to-Q	275	—	425	275	375	425	275	—	425	ps
	IN (Single-Ended)-to-Q	250	—	450	250	400	450	250	—	450	ps
	SEL-to-Q	250	—	450	250	400	450	250	—	450	ps
	LVPECL/LVECL										
	Diff. IN-to-Q	275	—	425	275	375	425	275	—	425	ps
	IN (Single-Ended)-to-Q	250	—	450	250	400	450	250	—	450	ps
	SEL-to-Q	250	—	450	250	400	450	250	—	450	ps
$t_{SKEW}^{(2)}$	Within-Device Skew (Diff.)	—	—	25	—	15	25	—	—	25	ps
	Part-to-Part Skew (Diff.)	—	—	150	—	100	150	—	—	150	ps
$t_S^{(3)}$	Set-Up Time /EN to CLK	100	0	—	100	0	—	100	0	—	ps
$t_H^{(3)}$	Hold Time /EN to CLK	200	50	—	200	50	—	200	50	—	ps
$t_{JITTER}$	Cycle-to-Cycle Jitter <sup>(4)</sup>	—	0.2	1	—	0.2	1	—	0.2	1	ps <sub>RMS</sub>
	Total Jitter (622MHz clock) <sup>(5)</sup>	—	<20	—	—	<20	—	—	<20	—	ps <sub>PP</sub>
$V_{ID}$	Input Voltage Range	150	800	1200	150	800	1200	150	800	1200	mV
$t_r, t_f$	Output Rise/Fall Times (20% to 80%)	75	—	225	75	130	225	85	—	225	ps

**Notes:**

- $f_{MAX}$  is defined as the maximum toggle frequency. Measured with 750mV input signal, 50% duty cycle, output swing  $\geq 400mV$ (diff), all loading with  $50\Omega$  to  $V_{CC}-2V$ .
- Skew is measured between outputs under identical transitions.
- Set-up and hold times apply to synchronous applications that intend to enable/disable before then ext clock cycle. For asynchronous applications, set-up and hold time does not apply.
- Cycle-to-cycle jitter definition: The variation in period between adjacent cycles over a random sample of adjacent cycle pairs.  $T_{JITTER\_CC} = T_n - T_{n+1}$  where T is the time between rising edges of the output signal.
- Total jitter definition: with an ideal clock input applied to one channel of the MUX, no more than one output edge in  $10^{12}$  output edges will deviate by more than the specified peak-to-peak jitter value.

**TERMINATION RECOMMENDATIONS**

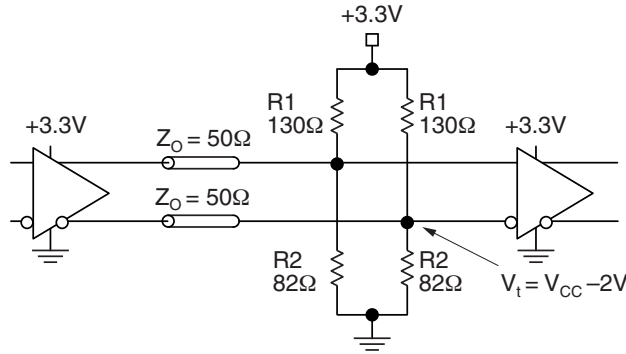

**Figure 1. Parallel Termination–Thevenin Equivalent**

**Notes:**

1. For +2.5V systems: R1 = 250Ω, R2 = 62.5Ω.
2. For +5.0V systems: R1 = 82Ω, R2 = 130Ω.

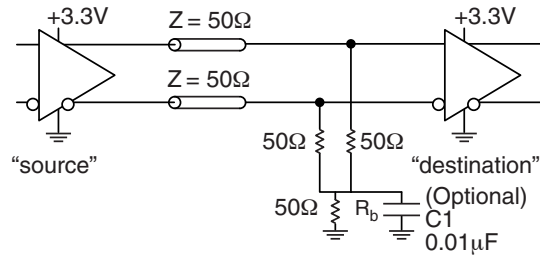

**Figure 2. Three-Resistor “Y-Termination”**

**Notes:**

1. Power-saving alternative to Thevenin termination.
2. Place termination resistors as close to destination inputs as possible.
3. R<sub>b</sub> resistor sets the DC bias voltage, equal to V<sub>T</sub>. For +3.3V systems R<sub>b</sub> = 46Ω to 50Ω. For +5V systems, R<sub>b</sub> = 110Ω.
4. C1 is an optional bypass capacitor intended to compensate for any tr/tf mismatches.

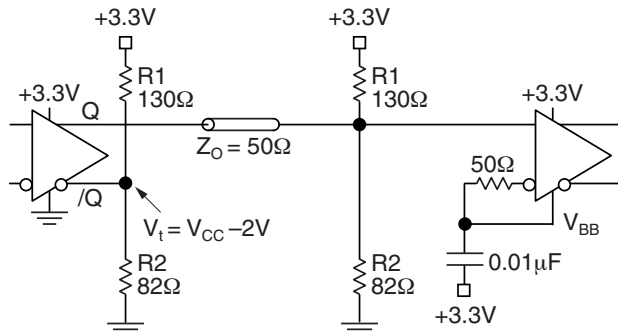
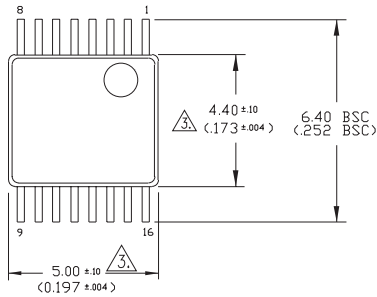

**Figure 3. Terminating Unused I/O**

**Notes**

1. Unused output (/Q) must be terminated to balance the output.
2. Micrel’s differential I/O logic devices include a V<sub>BB</sub> reference pin .
3. Connect unused input through 50Ω to V<sub>BB</sub>. Bypass with a 0.01μF capacitor to V<sub>CC</sub>, not GND.
4. For +2.5V systems: R1 = 250Ω, R2 = 62.5Ω.

**16-PIN TSSOP (K4-16-1)**



TOP VIEW

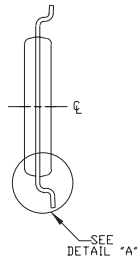

END VIEW

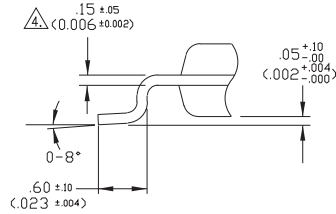

DETAIL "A"  
(VIEW ROTATED 90° C.W.)

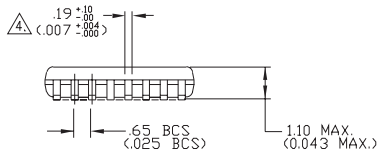

SIDE VIEW

- NOTES:
1. DIMENSIONS ARE IN MM[INCHES].
  2. CONTROLLING DIMENSION: MM.
- ⚠ DIMENSION DOES NOT INCLUDE MOLD FLASH OF 0.254[0.010] MAX.
- ⚠ THIS DIMENSION INCLUDES LEAD FINISH.

Rev. 01

**MICREL, INC. 2180 FORTUNE DRIVE SAN JOSE, CA 95131 USA**

TEL + 1 (408) 944-0800 FAX + 1 (408) 474-1000 WEB <http://www.micrel.com>

The information furnished by Micrel in this datasheet is believed to be accurate and reliable. However, no responsibility is assumed by Micrel for its use. Micrel reserves the right to change circuitry and specifications at any time without notification to the customer.

Micrel Products are not designed or authorized for use as components in life support appliances, devices or systems where malfunction of a product can reasonably be expected to result in personal injury. Life support devices or systems are devices or systems that (a) are intended for surgical implant into the body or (b) support or sustain life, and whose failure to perform can be reasonably expected to result in a significant injury to the user. A Purchaser's use or sale of Micrel Products for use in life support appliances, devices or systems is at Purchaser's own risk and Purchaser agrees to fully indemnify Micrel for any damages resulting from such use or sale.

© 2005 Micrel, Incorporated.

## Looking for pricing, stock, or lifecycle information?

Click below to explore more details on WIN SOURCE:

- ⊖ [View SY100EP15VK4G on WIN SOURCE](#)
- ⊖ [Microchip Technology Information](#)

## Optimize Your Supply Chain with WIN SOURCE Solutions

- ✓ Global Sourcing Solution
- ✓ Obsolete Management
- ✓ Cost Control Management
- ✓ Shortage Management
- ✓ Alternative Solution
- ✓ Excess Inventory Management