

DRV8832 Low-Voltage Motor Driver IC

1 Features

- H-Bridge Voltage-Controlled Motor Driver
 - Drives DC Motor, One Winding of a Stepper Motor, or Other Actuators/Loads
 - Efficient PWM Voltage Control for Constant Motor Speed With Varying Supply Voltages
 - Low MOSFET On-Resistance: HS + LS 450 mΩ
- 1-A Maximum DC/RMS or Peak Drive Current
- 2.75-V to 6.8-V Operating Supply Voltage Range
- 300-nA (Typical) Sleep Mode Current
- Reference Voltage Output
- Current Limit Circuit
- Fault Output
- Thermally-Enhanced Surface Mount Packages

2 Applications

- Battery-Powered:
 - Printers
 - Toys
 - Robotics
 - Cameras
 - Phones
- Small Actuators, Pumps, and so forth

3 Description

The DRV8832 provides an integrated motor driver solution for battery-powered toys, printers, and other low-voltage or battery-powered motion control applications. The device has one H-bridge driver, and can drive one DC motor or one winding of a stepper motor, as well as other loads like solenoids. The output driver block consists of N-channel and P-channel power MOSFETs configured as an H-bridge to drive the motor winding.

Provided with sufficient PCB heatsinking, the DRV8832 can supply up to 1 A of DC/RMS or peak output current. The device operates on power supply voltages from 2.75 V to 6.8 V.

To maintain constant motor speed over varying battery voltages while maintaining long battery life, a PWM voltage regulation method is provided. An input pin allows programming of the regulated voltage. A built-in voltage reference output is also provided.

Internal protection functions are provided for overcurrent protection, short-circuit protection, undervoltage lockout, and overtemperature protection.

The DRV8832 also provides a current limit function to regulate the motor current during conditions like motor start-up or stall, as well as a fault output pin to signal a host processor of a fault condition.

The DRV8832 is available in a tiny 3-mm × 3-mm 10-pin VSON package and MSOP PowerPAD™ package (Eco-friendly: RoHS & no Sb/Br).

Device Information⁽¹⁾

| PART NUMBER | PACKAGE | BODY SIZE (NOM) |
|-------------|--------------------|-------------------|
| DRV8832 | MSOP PowerPAD (10) | 3.00 mm × 3.00 mm |
| | VSON (10) | 3.00 mm × 3.00 mm |

(1) For all available packages, see the orderable addendum at the end of the data sheet.

Simplified Schematic

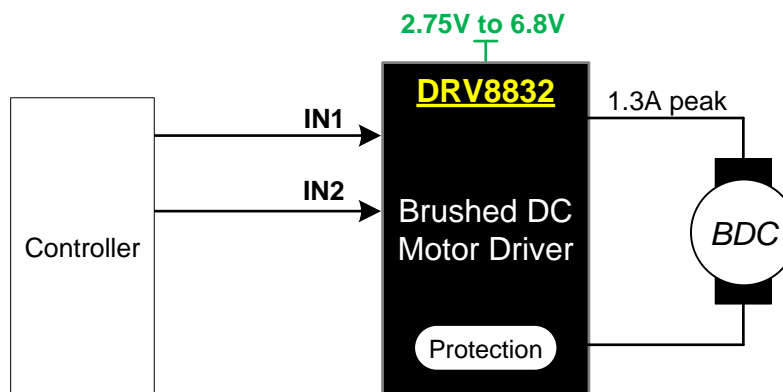

Table of Contents

| | | | |
|--|----------|--|-----------|
| 1 Features | 1 | 8 Application and Implementation | 11 |
| 2 Applications | 1 | 8.1 Application Information..... | 11 |
| 3 Description | 1 | 8.2 Typical Application | 11 |
| 4 Revision History | 2 | 9 Power Supply Recommendations | 15 |
| 5 Pin Configuration and Functions | 3 | 9.1 Bulk Capacitance | 15 |
| 6 Specifications | 4 | 9.2 Power Supervisor..... | 15 |
| 6.1 Absolute Maximum Ratings | 4 | 10 Layout | 16 |
| 6.2 ESD Ratings | 4 | 10.1 Layout Guidelines | 16 |
| 6.3 Recommended Operating Conditions..... | 4 | 10.2 Layout Example | 16 |
| 6.4 Thermal Information | 4 | 10.3 Thermal Considerations..... | 16 |
| 6.5 Electrical Characteristics..... | 5 | 11 Device and Documentation Support | 18 |
| 6.6 Typical Characteristics..... | 6 | 11.1 Documentation Support | 18 |
| 7 Detailed Description | 7 | 11.2 Community Resources..... | 18 |
| 7.1 Overview | 7 | 11.3 Trademarks | 18 |
| 7.2 Functional Block Diagram | 7 | 11.4 Electrostatic Discharge Caution..... | 18 |
| 7.3 Feature Description..... | 7 | 11.5 Glossary | 18 |
| 7.4 Device Functional Modes..... | 10 | 12 Mechanical, Packaging, and Orderable Information | 18 |

4 Revision History

NOTE: Page numbers for previous revisions may differ from page numbers in the current version.

| Changes from Revision H (October 2013) to Revision I | Page |
|--|-------------|
| • Added <i>ESD Ratings</i> table, <i>Feature Description</i> section, <i>Device Functional Modes</i> , <i>Application and Implementation</i> section, <i>Power Supply Recommendations</i> section, <i>Layout</i> section, <i>Device and Documentation Support</i> section, and <i>Mechanical, Packaging, and Orderable Information</i> section | 1 |
| • Added V_{HYS} parameter row under the Logic-Level Inputs section in <i>Electrical Characteristics</i> | 5 |
| • Changed the paragraph describing the FAULT behavior in <i>Current Limit</i> | 10 |
| • Updated the paragraphs in <i>Power Dissipation</i> and added Equation 4 | 16 |

5 Pin Configuration and Functions

DGQ and DRC Packages
10-Pin MSOP PowerPAD and VSON
Top View

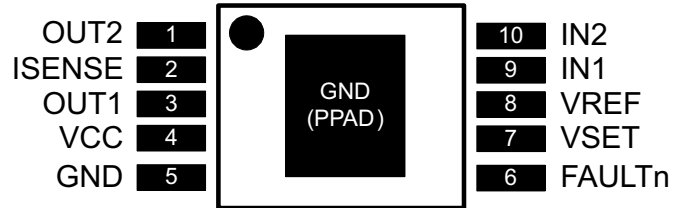

Pin Functions

| PIN | | I/O | DESCRIPTION | |
|--------|-----|-----|--------------------------|---|
| NAME | NO. | | | |
| FAULTn | 6 | OD | Fault output | Open-drain output driven low if fault condition present |
| GND | 5 | — | Device ground | |
| IN1 | 9 | I | Bridge A input 1 | Logic high sets OUT1 high |
| IN2 | 10 | I | Bridge A input 2 | Logic high sets OUT2 high |
| ISENSE | 2 | IO | Current sense resistor | Connect current sense resistor to GND. Resistor value sets current limit level. |
| OUT1 | 3 | O | Bridge output 1 | Connect to motor winding |
| OUT2 | 1 | O | Bridge output 2 | Connect to motor winding |
| VCC | 4 | — | Device and motor supply | Bypass to GND with a 0.1- μ F (minimum) ceramic capacitor. |
| VREF | 8 | O | Reference voltage output | Reference voltage output |
| VSET | 7 | I | Voltage set input | Input voltage sets output regulation voltage |

6 Specifications

6.1 Absolute Maximum Ratings

 over operating free-air temperature range (unless otherwise noted) ⁽¹⁾⁽²⁾

| | | MIN | MAX | UNIT |
|------------------|--|---|-----|------|
| | Power supply voltage, VCC | -0.3 | 7 | V |
| | Input pin voltage | -0.5 | 7 | V |
| | Peak motor drive output current ⁽³⁾ | Internally limited | | A |
| | Continuous motor drive output current ⁽³⁾ | -1 | 1 | A |
| | Continuous total power dissipation | See Thermal Information | | |
| T _J | Operating virtual junction temperature | -40 | 150 | °C |
| T _{stg} | Storage temperature | -60 | 150 | °C |

- (1) Stresses beyond those listed under *Absolute Maximum Ratings* may cause permanent damage to the device. These are stress ratings only, which do not imply functional operation of the device at these or any other conditions beyond those indicated under *Recommended Operating Conditions*. Exposure to absolute-maximum-rated conditions for extended periods may affect device reliability.
- (2) All voltage values are with respect to network ground terminal.
- (3) Power dissipation and thermal limits must be observed.

6.2 ESD Ratings

| | | VALUE | UNIT |
|--------------------|-------------------------|--|-------|
| V _(ESD) | Electrostatic discharge | Human body model (HBM), per ANSI/ESDA/JEDEC JS-001, all pins ⁽¹⁾ | ±2500 |
| | | Charged device model (CDM), per JEDEC specification JESD22-C101, all pins ⁽²⁾ | ±1000 |

- (1) JEDEC document JEP155 states that 500-V HBM allows safe manufacturing with a standard ESD control process.
- (2) JEDEC document JEP157 states that 250-V CDM allows safe manufacturing with a standard ESD control process.

6.3 Recommended Operating Conditions

over operating free-air temperature range (unless otherwise noted)

| | | MIN | NOM | MAX | UNIT |
|------------------|---|------|-----|-----|------|
| V _{CC} | Motor power supply voltage | 2.75 | | 6.8 | V |
| I _{OUT} | Continuous or peak H-bridge output current ⁽¹⁾ | 0 | | 1 | A |

- (1) Power dissipation and thermal limits must be observed.

6.4 Thermal Information

| THERMAL METRIC ⁽¹⁾ | DRV8832 | | UNIT | |
|-------------------------------|--|------------|------|------|
| | DGQ (MSOP PowerPAD) | DRC (VSON) | | |
| | 10 PINS | 10 PINS | | |
| R _{θJA} | Junction-to-ambient thermal resistance | 69.3 | 50.2 | °C/W |
| R _{θJC(top)} | Junction-to-case (top) thermal resistance | 63.5 | 78.4 | °C/W |
| R _{θJB} | Junction-to-board thermal resistance | 51.6 | 18.8 | °C/W |
| Ψ _{JT} | Junction-to-top characterization parameter | 1.5 | 1.1 | °C/W |
| Ψ _{JB} | Junction-to-board characterization parameter | 23.2 | 17.9 | °C/W |
| R _{θJC(bot)} | Junction-to-case (bottom) thermal resistance | 9.5 | 5.1 | °C/W |

- (1) For more information about traditional and new thermal metrics, see the *Semiconductor and IC Package Thermal Metrics* application report, [SPRA953](#).

6.5 Electrical Characteristics

 $V_{CC} = 2.75\text{ V to }6.8\text{ V}$, $T_A = -40^\circ\text{C to }85^\circ\text{C}$ (unless otherwise noted)

| PARAMETER | | TEST CONDITIONS | MIN | TYP | MAX | UNIT |
|-------------------------------------|--|--|-----------|------------|-------|------------------|
| POWER SUPPLIES | | | | | | |
| I_{VCC} | VCC operating supply current | $V_{CC} = 5\text{ V}$ | | 1.4 | 2 | mA |
| I_{VCCQ} | VCC sleep mode supply current | $V_{CC} = 5\text{ V}$, $T_A = 25^\circ\text{C}$ | | 0.3 | 1 | μA |
| V_{UVLO} | VCC undervoltage lockout voltage | V_{CC} rising | | 2.575 | 2.75 | V |
| | | V_{CC} falling | | 2.47 | | |
| LOGIC-LEVEL INPUTS | | | | | | |
| V_{IL} | Input low voltage | | | 0.25 × VCC | | V |
| V_{HYS} | Input hysteresis | | | 0.08 × Vcc | | V |
| V_{IH} | Input high voltage | | 0.5 × VCC | | | V |
| I_{IL} | Input low current | $V_{IN} = 0$ | -10 | | 10 | μA |
| I_{IH} | Input high current | $V_{IN} = 3.3\text{ V}$ | | | 50 | μA |
| LOGIC-LEVEL OUTPUTS (FAULTn) | | | | | | |
| V_{OL} | Output low voltage | $V_{CC} = 5\text{ V}$, $I_{OL} = 4\text{ mA}^{(1)}$ | | 0.5 | | V |
| H-BRIDGE FETS | | | | | | |
| $R_{DS(ON)}$ | HS FET on resistance | $V_{CC} = 5\text{ V}$, $I_O = 0.8\text{ A}$, $T_J = 85^\circ\text{C}$ | | 290 | 400 | m Ω |
| | | $V_{CC} = 5\text{ V}$, $I_O = 0.8\text{ A}$, $T_J = 25^\circ\text{C}$ | | 250 | | |
| $R_{DS(ON)}$ | LS FET on resistance | $V_{CC} = 5\text{ V}$, $I_O = 0.8\text{ A}$, $T_J = 85^\circ\text{C}$ | | 230 | 320 | m Ω |
| | | $V_{CC} = 5\text{ V}$, $I_O = 0.8\text{ A}$, $T_J = 25^\circ\text{C}$ | | 200 | | |
| I_{OFF} | Off-state leakage current | | -20 | | 20 | μA |
| MOTOR DRIVER | | | | | | |
| t_R | Rise time | $V_{CC} = 3\text{ V}$, load = 4 Ω | 50 | | 300 | ns |
| t_F | Fall time | $V_{CC} = 3\text{ V}$, load = 4 Ω | 50 | | 300 | ns |
| f_{SW} | Internal PWM frequency | | | 44.5 | | kHz |
| PROTECTION CIRCUITS | | | | | | |
| I_{OCP} | Overcurrent protection trip level | | 1.3 | | 3 | A |
| t_{OCP} | OCP deglitch time | | | 2 | | μs |
| T_{TSD} | Thermal shutdown temperature | Die temperature ⁽¹⁾ | 150 | 160 | 180 | $^\circ\text{C}$ |
| VOLTAGE CONTROL | | | | | | |
| V_{REF} | Reference output voltage | | 1.235 | 1.285 | 1.335 | V |
| ΔV_{LINE} | Line regulation | $V_{CC} = 3.3\text{ V to }6\text{ V}$, $V_{OUT} = 3\text{ V}^{(1)}$ $I_{OUT} = 500\text{ mA}$ | | ±1% | | |
| ΔV_{LOAD} | Load regulation | $V_{CC} = 5\text{ V}$, $V_{OUT} = 3\text{ V}$ $I_{OUT} = 200\text{ mA to }800\text{ mA}^{(1)}$ | | ±1% | | |
| CURRENT LIMIT | | | | | | |
| V_{ILIM} | Current limit sense voltage | | 160 | 200 | 240 | mV |
| t_{ILIM} | Current limit fault deglitch time | | | 275 | | ms |
| R_{ISEN} | Current limit set resistance (external resistor value) | | 0 | | 1 | Ω |

(1) Not production tested.

6.6 Typical Characteristics

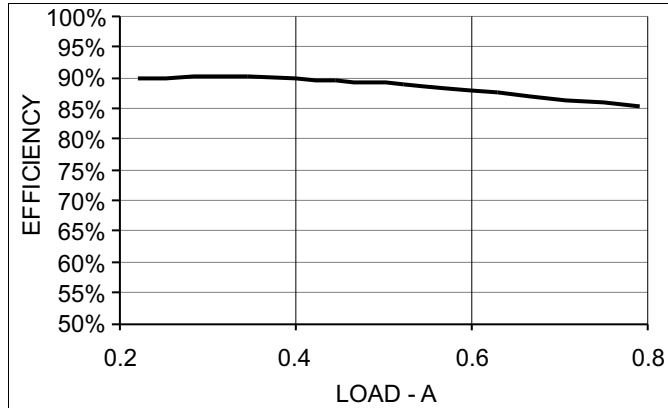

Figure 1. Efficiency vs Load Current
($V_{IN} = 5\text{ V}$, $V_{OUT} = 3\text{ V}$)

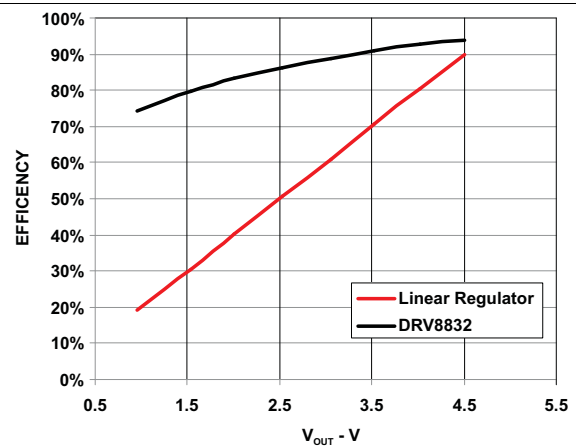

Figure 2. Efficiency vs Output Voltage
($V_{IN} = 5\text{ V}$, $I_{OUT} = 500\text{ mA}$)

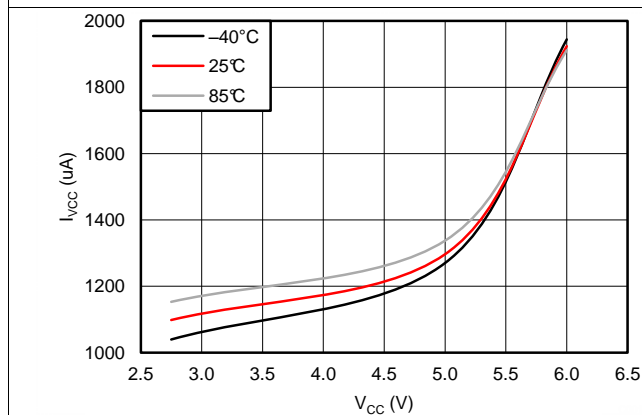

Figure 3. I_{VCC} vs V_{VCC}

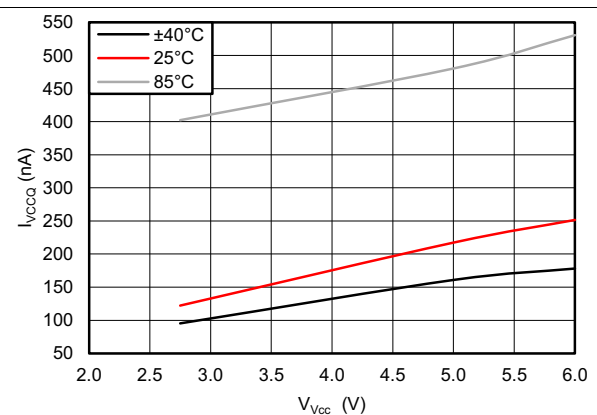

Figure 4. I_{VCCQ} vs V_{VCC}

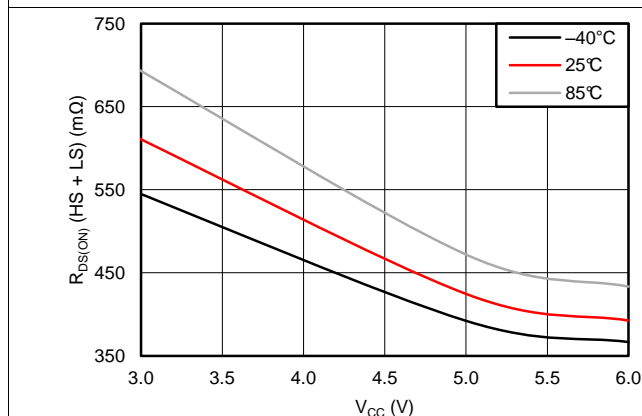

Figure 5. $R_{DS(ON)}$ HS + LS vs V_{VCC}

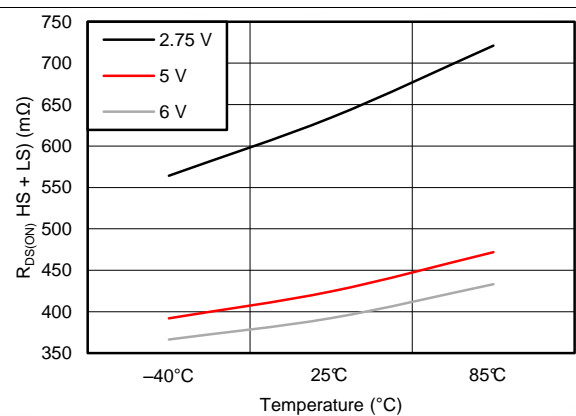

Figure 6. $R_{DS(ON)}$ HS + LS vs Temperature

7 Detailed Description

7.1 Overview

The DRV8832 is an integrated motor driver solution used for brushed motor control. The device integrates one H-bridge, current regulation circuitry, and a PWM voltage regulation method.

Using the PWM voltage regulation allows the motor to maintain the desired speed as VCC changes. Battery operation is an example of using this feature. When the battery is new or fully charged VCC will be higher than when the battery is old or partially discharged. The speed of the motor will vary based on the voltage of the battery. By setting the desired voltage across the motor at a lower voltage, a fully charged battery will use less power and spin the motor at the same speed as a battery that has been partially discharged.

7.2 Functional Block Diagram

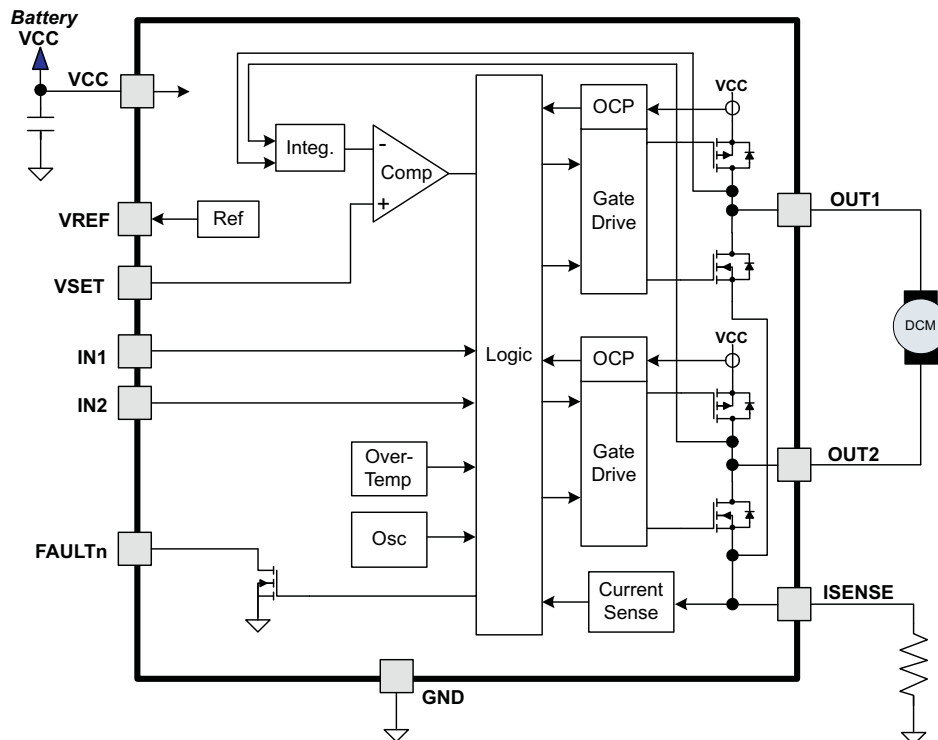

7.3 Feature Description

7.3.1 PWM Motor Driver

The DRV8832 contains an H-bridge motor driver with PWM voltage-control circuitry with current limit circuitry. [Figure 7](#) shows a block diagram of the motor control circuitry.

Feature Description (continued)

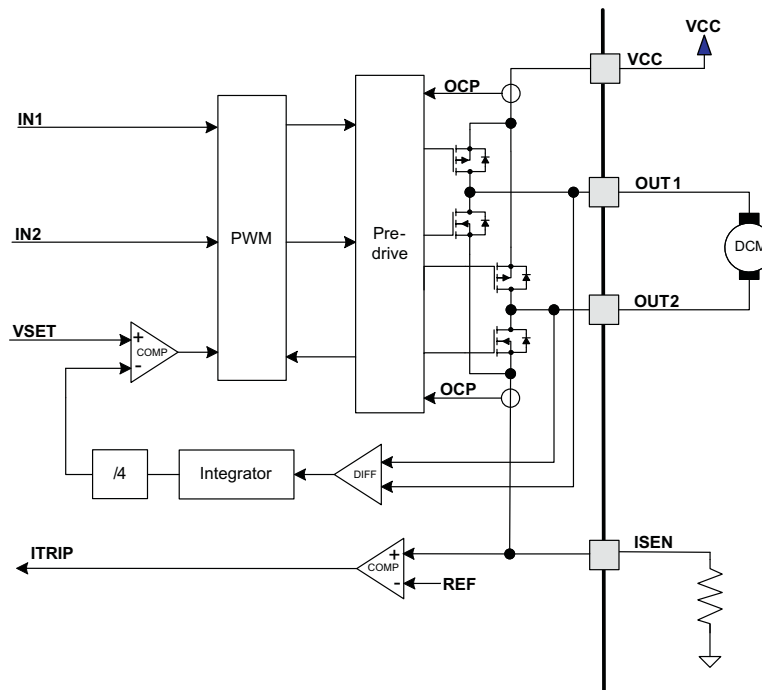

Figure 7. Motor Control Circuitry

7.3.2 Bridge Control

The IN1 and IN2 control pins enable the H-bridge outputs. [Table 1](#) shows the logic:

Table 1. H-Bridge Logic

| IN1 | IN2 | OUT1 | OUT2 | Function |
|-----|-----|------|------|-------------|
| 0 | 0 | Z | Z | Sleep/Coast |
| 0 | 1 | L | H | Reverse |
| 1 | 0 | H | L | Forward |
| 1 | 1 | H | H | Brake |

When both inputs are low, the output drivers are disabled and the device is placed into a low-power sleep state. The current limit fault condition (if present) is also cleared. Note that when transitioning from either brake or sleep mode to forward or reverse, the voltage control PWM starts at zero duty cycle. The duty cycle slowly ramps up to the commanded voltage. This can take up to 12 ms to go from sleep to 100% duty cycle. Because of this, high-speed PWM signals cannot be applied to the IN1 and IN2 pins. To control motor speed, use the VSET pin as described below.

Because of the sleep mode functionality described previously, when applying an external PWM to the DRV8832, hold one input logic high while applying a PWM signal to the other. If the logic input is held low instead, then the device will cycle in and out of sleep mode, causing the FAULTn pin to pulse low on every sleep mode exit.

7.3.3 Voltage Regulation

The DRV8832 provides the ability to regulate the voltage applied to the motor winding. This feature allows constant motor speed to be maintained even when operating from a varying supply voltage such as a discharging battery.

The DRV8832 uses a pulse-width modulation (PWM) technique instead of a linear circuit to minimize current consumption and maximize battery life.

The circuit monitors the voltage difference between the output pins and integrates it, to get an average DC voltage value. This voltage is divided by 4 and compared to the VSET pin voltage. If the averaged output voltage (divided by 4) is lower than VSET, the duty cycle of the PWM output is increased; if the averaged output voltage (divided by 4) is higher than VSET, the duty cycle is decreased.

During PWM regulation, the H-bridge is enabled to drive current through the motor winding during the PWM on time. This is shown in the diagram below as case 1. The current flow direction shown indicates the state when IN1 is high and IN2 is low.

Note that if the programmed output voltage is greater than the supply voltage, the device will operate at 100% duty cycle and the voltage regulation feature will be disabled. In this mode the device behaves as a conventional H-bridge driver.

During the PWM off time, winding current is recirculated by enabling both of the high-side FETs in the bridge as shown in [Figure 8](#).

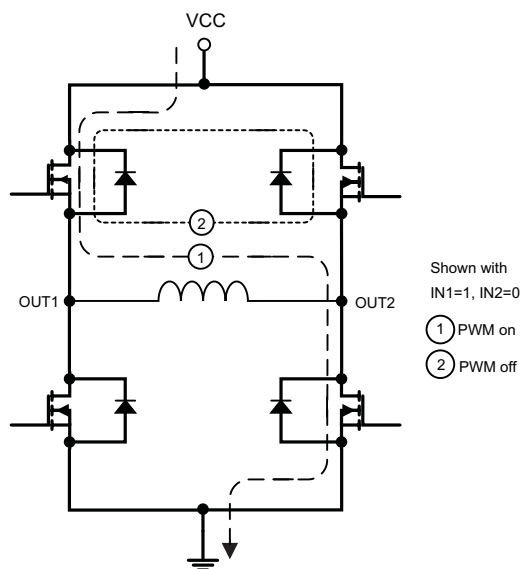

Figure 8. Voltage Regulation

7.3.4 Reference Output

The DRV8832 includes a reference voltage output that can be used to set the motor voltage. Typically for a constant-speed application, VSET is driven from VREF through a resistor divider to provide a voltage equal to 1/4 the desired motor drive voltage.

For example, if VREF is connected directly to VSET, the voltage will be regulated at 5.14 V. If the desired motor voltage is 3 V, VREF should be 0.75 V. This can be obtained with a voltage divider using 53 kΩ from VREF to VSET, and 75 kΩ from VSET to GND.

7.3.5 Current Limit

A current limit circuit is provided to protect the system in the event of an overcurrent condition, such as what would be encountered if driving a DC motor at start-up or with an abnormal mechanical load (stall condition).

The motor current is sensed by monitoring the voltage across an external sense resistor. When the voltage exceeds a reference voltage of 200 mV for more than approximately 3 μs, the PWM duty cycle is reduced to limit the current through the motor to this value. This current limit allows for starting the motor while controlling the current.

If the current limit condition persists for some time, it is likely that a fault condition has been encountered, such as the motor being run into a stop or a stalled condition. An overcurrent event must persist for approximately 275 ms before the fault is registered. After approximately 275 ms, a fault signaled to the host by driving the FAULTn signal low. Operation of the motor driver will continue.

The current limit fault condition is self-clearing and will be released when the abnormal load (stall condition) is removed.

The resistor used to set the current limit must be less than 1 Ω . Its value may be calculated using [Equation 1](#):

$$R_{ISENSE} = \frac{200 \text{ mV}}{I_{LIMIT}}$$

where

- R_{ISENSE} is the current sense resistor value
 - I_{LIMIT} is the desired current limit (in mA)
- (1)

If the current limit feature is not needed, the ISENSE pin may be directly connected to ground.

7.3.6 Protection Circuits

The DRV8832 is fully protected against undervoltage, overcurrent and overtemperature events.

7.3.6.1 Overcurrent Protection (OCP)

An analog current limit circuit on each FET limits the current through the FET by removing the gate drive. If this analog current limit persists for longer than the OCP time, all FETs in the H-bridge will be disabled, and the FAULTn signal will be driven low. The device will remain disabled until VCC is removed and re-applied.

Overcurrent conditions are sensed independently on both high and low side devices. A short to ground, supply, or across the motor winding will all result in an overcurrent shutdown. Note that OCP is independent of the current limit function, which is typically set to engage at a lower current level; the OCP function is intended to prevent damage to the device under abnormal (for example, short-circuit) conditions.

7.3.6.2 Thermal Shutdown (TSD)

If the die temperature exceeds safe limits, all FETs in the H-bridge will be disabled and the FAULTn signal will be driven low. Once the die temperature has fallen to a safe level operation will automatically resume.

7.3.6.3 Undervoltage Lockout (UVLO)

If at any time the voltage on the VCC pins falls below the undervoltage lockout threshold voltage, all circuitry in the device will be disabled, the FAULTn signal will be driven low, and internal logic will be reset. Operation will resume when VCC rises above the UVLO threshold.

Table 2. Device Protection

| FAULT | CONDITION | ERROR REPORT | H-BRIDGE | INTERNAL CIRCUITS | RECOVERY |
|-------------------------|---------------------|--------------|----------|-------------------|---------------------------|
| VCC undervoltage (UVLO) | $VCC < V_{UVLO}$ | FAULTn | Disabled | Disabled | $VCC > V_{UVLO}$ |
| Overcurrent (OCP) | $I_{OUT} > I_{OCP}$ | FAULTn | Disabled | Operating | Power Cycle VCC |
| Thermal Shutdown (TSD) | $T_J > T_{TSD}$ | FAULTn | Disabled | Operating | $T_J < T_{TSD} - T_{HYS}$ |

7.4 Device Functional Modes

The DRV8832 is active when either IN1 or IN2 are set to a logic high. Sleep mode is entered when both IN1 and IN2 are set to a logic low. When in sleep mode, the H-bridge FETs are disabled (Hi-Z).

Table 3. Modes of Operation

| FAULT | CONDITION | H-BRIDGE | INTERNAL CIRCUITS |
|-------------------|-------------------------|-----------|-----------------------------|
| Operating | IN1 or IN2 high | Operating | Operating |
| Sleep mode | IN1 and IN2 low | Disabled | Disabled |
| Fault encountered | Any fault condition met | Disabled | See Table 2 |

8 Application and Implementation

NOTE

Information in the following applications sections is not part of the TI component specification, and TI does not warrant its accuracy or completeness. TI's customers are responsible for determining suitability of components for their purposes. Customers should validate and test their design implementation to confirm system functionality.

8.1 Application Information

The DRV8832 is used in brushed DC applications to provide a constant motor speed over varying voltages. The following design procedure can be used to configure the DRV8832 for a system with a VCC variance of 4 V to 6 V.

8.2 Typical Application

Figure 9 shows a common application of the DRV8832.

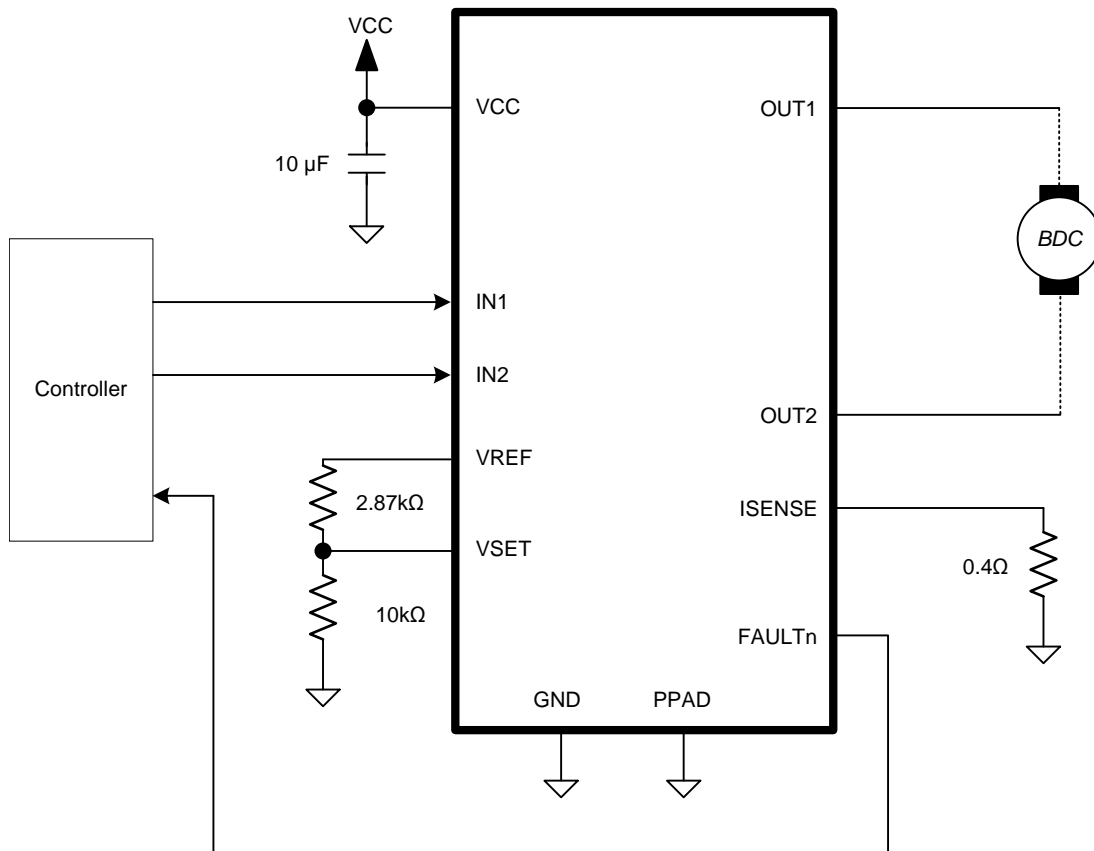

Figure 9. Typical Application Schematic

Typical Application (continued)

8.2.1 Design Requirements

Table 4 lists the design parameters for this application.

Table 4. Design Parameters

| DESIGN PARAMETER | REFERENCE | EXAMPLE VALUE |
|--------------------------|-------------|---------------|
| Motor voltage | V_{CC} | 4 V |
| Motor RMS current | I_{RMS} | 0.3 A |
| Motor start-up current | I_{START} | 0.6 A |
| Motor current trip point | I_{LIMIT} | 0.5 A |

8.2.2 Detailed Design Procedure

8.2.2.1 Motor Voltage

The motor voltage to use will depend on the ratings of the motor selected and the desired RPM. A higher voltage spins a brushed DC motor faster with the same PWM duty cycle applied to the power FETs. A higher voltage also increases the rate of current change through the inductive motor windings.

For the DRV8832, TI recommends setting a motor voltage at the lowest system VCC. This will maintain a constant RPM across varying VCC conditions.

For example if the VCC voltage can vary from 4.5 V to 5.5 V, setting the VSET voltage to 1.125 V will compensate for power supply variation. The DRV8832 will set the motor voltage at 4.5 V, even if VCC is 5.5 V.

8.2.2.2 Motor Current Trip Point

When the voltage on pin ISENSE exceeds V_{ILIM} (0.2 V), overcurrent is detected. The R_{SENSE} resistor should be sized to set the desired I_{LIMIT} level.

$$R_{SENSE} = 0.2 \text{ V} / I_{LIMIT} \quad (2)$$

To set I_{LIMIT} to 5 A, $R_{SENSE} = 0.2 \text{ V} / 0.5 \text{ A} = 0.4 \Omega$.

To prevent false trips, I_{LIMIT} must be higher than regular operating current. Motor current during start-up is typically much higher than steady-state spinning, because the initial load torque is higher, and the absence of back-EMF causes a higher voltage and extra current across the motor windings.

It can be beneficial to limit start-up current by using series inductors on the DRV8832 output, as that allows I_{LIMIT} to be lower, and it may decrease the system's required bulk capacitance. Start-up current can also be limited by ramping the forward drive duty cycle.

8.2.2.3 Sense Resistor

For optimal performance, it is important for the sense resistor to be:

- Surface-mount
- Low inductance
- Rated for high enough power
- Placed closely to the motor driver

The power dissipated by the sense resistor equals $I_{RMS}^2 \times R$. For example, if peak motor current is 1 A, RMS motor current is 0.7 A, and a 0.4- Ω sense resistor is used, the resistor will dissipate $0.7 \text{ A}^2 \times 0.4 \Omega = 0.2 \text{ W}$. The power quickly increases with higher current levels.

Resistors typically have a rated power within some ambient temperature range, along with a derated power curve for high ambient temperatures. When a PCB is shared with other components generating heat, margin should be added. It is always best to measure the actual sense resistor temperature in a final system, along with the power MOSFETs, as those are often the hottest components.

Because power resistors are larger and more expensive than standard resistors, it is common practice to use multiple standard resistors in parallel, between the sense node and ground. This distributes the current and heat dissipation.

8.2.2.4 Low Power Operation

Under normal operation, using sleep mode to minimize supply current should be sufficient.

If desired, power can be removed to the DRV8832 to further decrease supply current. TI recommends removing power to the FAULTn pullup resistor when removing power to the DRV8832. Removing power from the FAULTn pullup resistor will eliminate a current path from the FAULTn pin through an ESD protection diode to VCC. TI also recommends setting both IN1 and IN2 as a logic low when power is removed.

8.2.3 Application Curves

The following scope captures show how the output duty cycle changes to as VCC increases. This allows the motor to spin at a constant speed as VCC changes. At VCC=3.9V, the output duty cycle is 100% on. As the VCC voltage increases to greater than 4 V, the output duty cycle begins to decrease. The output duty cycle is shown at VCC=4.5 V, VCC=5 V and VCC=5.5 V.

- Channel 1 – OUT1: IN1 – Logic Low
- Channel 2 – OUT2: IN2 – Logic High
- Channel 4 – Motor current: VSET – 1 V
- Motor used: NMB Technologies Corporation, PPN7PA12C1

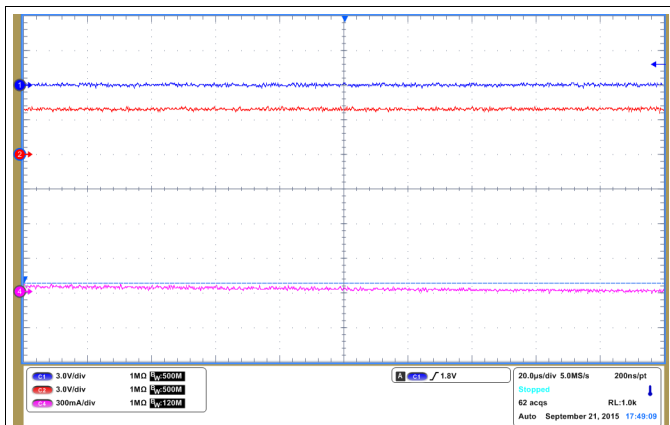

Figure 10. Output Pulse Width Modulating at VCC = 3.9 V

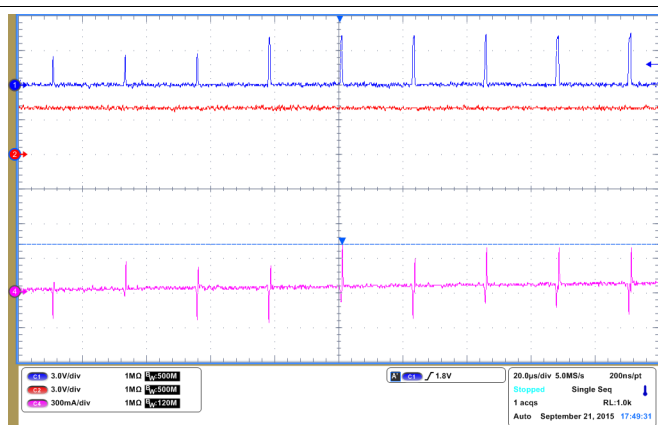

Figure 11. Output Pulse Width Modulating at VCC = 4 V

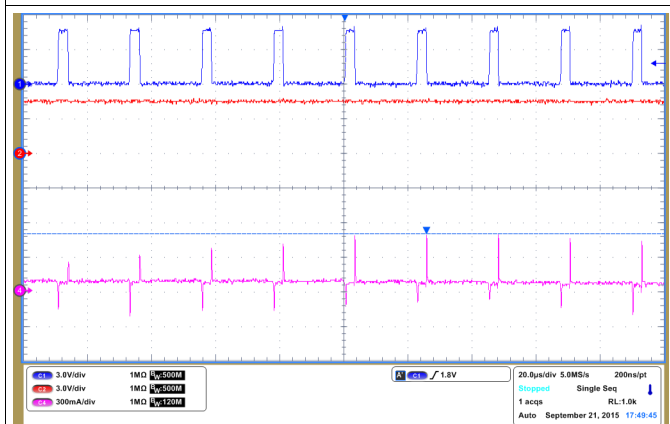

Figure 12. Output Pulse Width Modulating at VCC = 4.5 V

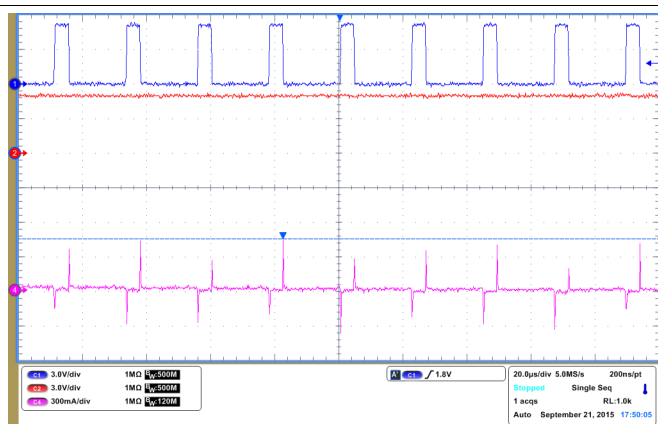

Figure 13. Output Pulse Width Modulating at VCC = 5 V

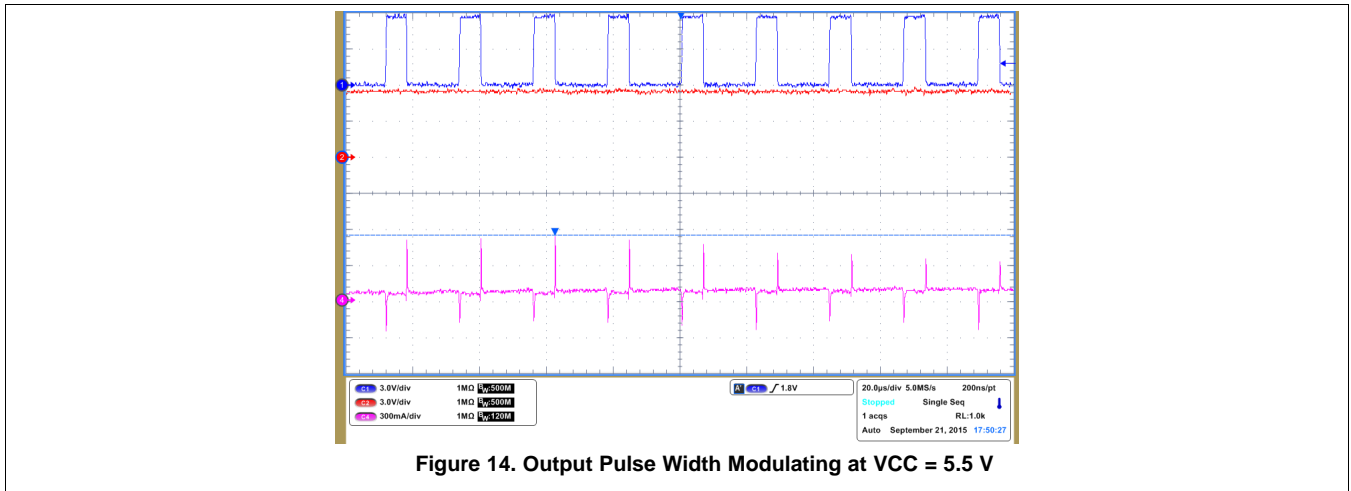

Figure 14. Output Pulse Width Modulating at VCC = 5.5 V

9 Power Supply Recommendations

9.1 Bulk Capacitance

Having an appropriate local bulk capacitance is an important factor in motor drive system design. It is generally beneficial to have more bulk capacitance, while the disadvantages are increased cost and physical size.

The amount of local capacitance needed depends on a variety of factors, including:

- The highest current required by the motor system
- The capacitance and ability to source current
- The amount of parasitic inductance between the power supply and motor system
- The acceptable voltage ripple
- The type of motor used (brushed DC, brushless DC, stepper)
- The motor braking method

The inductance between the power supply and the motor drive system limits the rate current can change from the power supply. If the local bulk capacitance is too small, the system responds to excessive current demands or dumps from the motor with a change in voltage. When adequate bulk capacitance is used, the motor voltage remains stable and high current can be quickly supplied.

The data sheet generally provides a recommended value, but system-level testing is required to determine the appropriate sized bulk capacitor.

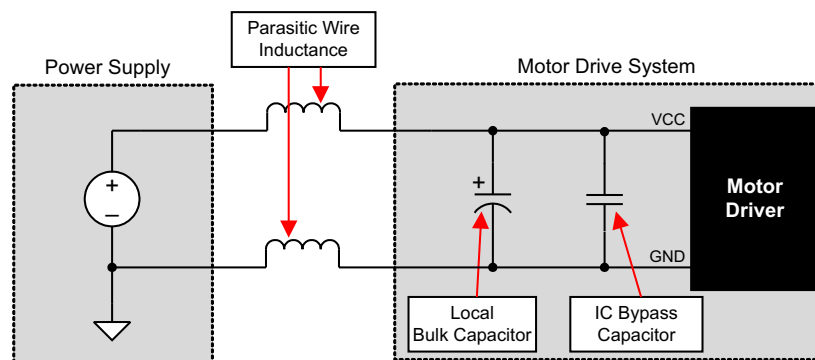

Figure 15. Example Setup of Motor Drive System With External Power Supply

The voltage rating for bulk capacitors should be higher than the operating voltage, to provide margin for cases when the motor transfers energy to the supply.

9.2 Power Supervisor

The DRV8832 is capable of entering a low-power sleep mode by bringing both of the INx control inputs logic low. The outputs will be disabled Hi-Z.

To exit the sleep mode, bring either or both of the INx inputs logic high. This will enable the H-bridges. When exiting the sleep mode, the FAULTn pin will pulse low.

10 Layout

10.1 Layout Guidelines

The VCC pin should be bypassed to GND using low-ESR ceramic bypass capacitors with a recommended value of 0.1- μ F rated for VCC. This capacitor should be placed as close to the VCC pin as possible with a thick trace or ground plane connection to the device GND pin.

The VCC pin must be bypassed to ground using an appropriate bulk capacitor. This component may be an electrolytic and should be located close to the DRV8832.

10.2 Layout Example

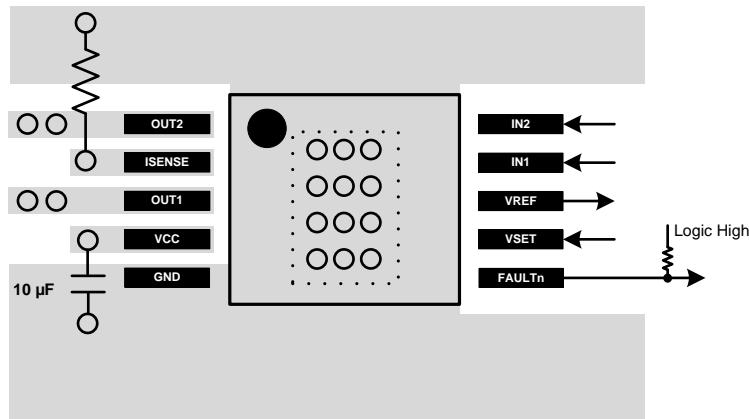

Figure 16. Recommended Layout

10.3 Thermal Considerations

The DRV8832 has thermal shutdown (TSD) as described [Thermal Shutdown \(TSD\)](#). If the die temperature exceeds approximately 160°C, the device will be disabled until the temperature drops to a safe level.

Any tendency of the device to enter TSD is an indication of either excessive power dissipation, insufficient heatsinking, or too high an ambient temperature.

10.3.1 Power Dissipation

The power dissipation of the DRV8832 is a function of RMS motor current and the each output's FET resistance ($R_{DS(ON)}$).

$$\text{Power} \approx I_{RMS}^2 \times (\text{High-Side } R_{DS(ON)} + \text{Low-Side } R_{DS(ON)}) \quad (3)$$

For this example, the ambient temperature is 35°C, and the junction temperature reaches 65°C. At 65°C, the sum of $R_{DS(ON)}$ is about 1 Ω . With an example motor current of 0.8 A, the dissipated power in the form of heat will be $0.8 \text{ A}^2 \times 1 \Omega = 0.64 \text{ W}$.

The temperature that the DRV8832 reaches will depend on the thermal resistance to the air and PCB. It is important to solder the device PowerPAD to the PCB ground plane, with vias to the top and bottom board layers, dissipate heat into the PCB and reduce the device temperature. In the example used here, the DRV8832 had an effective thermal resistance $R_{\theta JA}$ of 47°C/W, and:

$$T_J = T_A + (P_O \times R_{\theta JA}) = 35^\circ\text{C} + (0.64 \text{ W} \times 47^\circ\text{C/W}) = 65^\circ\text{C} \quad (4)$$

10.3.2 Heatsinking

The PowerPAD™ package uses an exposed pad to remove heat from the device. For proper operation, this pad must be thermally connected to copper on the PCB to dissipate heat. On a multi-layer PCB with a ground plane, this can be accomplished by adding a number of vias to connect the thermal pad to the ground plane. On PCBs without internal planes, copper area can be added on either side of the PCB to dissipate heat. If the copper area is on the opposite side of the PCB from the device, thermal vias are used to transfer the heat between top and bottom layers.

Thermal Considerations (continued)

For details about how to design the PCB, refer to TI application report [SLMA002](#), *PowerPAD™ Thermally Enhanced Package* and TI application brief [SLMA004](#), *PowerPAD™ Made Easy*, available at www.ti.com.

In general, the more copper area that can be provided, the more power can be dissipated.

11 Device and Documentation Support

11.1 Documentation Support

11.1.1 Related Documentation

For related documentation see the following:

- *PowerPAD™ Thermally Enhanced Package* [SLMA002](#)
- *PowerPAD™ Made Easy* [SLMA004](#)

11.2 Community Resources

The following links connect to TI community resources. Linked contents are provided "AS IS" by the respective contributors. They do not constitute TI specifications and do not necessarily reflect TI's views; see TI's [Terms of Use](#).

TI E2E™ Online Community *TI's Engineer-to-Engineer (E2E) Community*. Created to foster collaboration among engineers. At e2e.ti.com, you can ask questions, share knowledge, explore ideas and help solve problems with fellow engineers.

Design Support *TI's Design Support* Quickly find helpful E2E forums along with design support tools and contact information for technical support.

11.3 Trademarks

PowerPAD, E2E are trademarks of Texas Instruments. All other trademarks are the property of their respective owners.

11.4 Electrostatic Discharge Caution



These devices have limited built-in ESD protection. The leads should be shorted together or the device placed in conductive foam during storage or handling to prevent electrostatic damage to the MOS gates.

11.5 Glossary

[SLYZ022](#) — *TI Glossary*.

This glossary lists and explains terms, acronyms, and definitions.

12 Mechanical, Packaging, and Orderable Information

The following pages include mechanical, packaging, and orderable information. This information is the most current data available for the designated devices. This data is subject to change without notice and revision of this document. For browser-based versions of this data sheet, refer to the left-hand navigation.

PACKAGING INFORMATION

| Orderable Device | Status (1) | Package Type | Package Drawing | Pins | Package Qty | Eco Plan (2) | Lead/Ball Finish (6) | MSL Peak Temp (3) | Op Temp (°C) | Device Marking (4/5) | Samples |
|------------------|---------------|-------------------|-----------------|------|-------------|----------------------------|-------------------------|----------------------|--------------|-------------------------|-------------------------|
| DRV8832DGQ | ACTIVE | MSOP- PowerPAD | DGQ | 10 | 80 | Green (RoHS & no Sb/Br) | CU NIPDAUAG | Level-2-260C-1 YEAR | -40 to 85 | 8832 | Samples |
| DRV8832DGQR | ACTIVE | MSOP- PowerPAD | DGQ | 10 | 2500 | Green (RoHS & no Sb/Br) | CU NIPDAUAG | Level-2-260C-1 YEAR | -40 to 85 | 8832 | Samples |
| DRV8832DRCR | ACTIVE | VSON | DRC | 10 | 3000 | Green (RoHS & no Sb/Br) | CU NIPDAU | Level-2-260C-1 YEAR | -40 to 85 | 8832 | Samples |
| DRV8832DRCT | ACTIVE | VSON | DRC | 10 | 250 | Green (RoHS & no Sb/Br) | CU NIPDAU | Level-2-260C-1 YEAR | -40 to 85 | 8832 | Samples |

(1) The marketing status values are defined as follows:

ACTIVE: Product device recommended for new designs.

LIFEBUY: TI has announced that the device will be discontinued, and a lifetime-buy period is in effect.

NRND: Not recommended for new designs. Device is in production to support existing customers, but TI does not recommend using this part in a new design.

PREVIEW: Device has been announced but is not in production. Samples may or may not be available.

OBSOLETE: TI has discontinued the production of the device.

(2) Eco Plan - The planned eco-friendly classification: Pb-Free (RoHS), Pb-Free (RoHS Exempt), or Green (RoHS & no Sb/Br) - please check <http://www.ti.com/productcontent> for the latest availability information and additional product content details.

TBD: The Pb-Free/Green conversion plan has not been defined.

Pb-Free (RoHS): TI's terms "Lead-Free" or "Pb-Free" mean semiconductor products that are compatible with the current RoHS requirements for all 6 substances, including the requirement that lead not exceed 0.1% by weight in homogeneous materials. Where designed to be soldered at high temperatures, TI Pb-Free products are suitable for use in specified lead-free processes.

Pb-Free (RoHS Exempt): This component has a RoHS exemption for either 1) lead-based flip-chip solder bumps used between the die and package, or 2) lead-based die adhesive used between the die and leadframe. The component is otherwise considered Pb-Free (RoHS compatible) as defined above.

Green (RoHS & no Sb/Br): TI defines "Green" to mean Pb-Free (RoHS compatible), and free of Bromine (Br) and Antimony (Sb) based flame retardants (Br or Sb do not exceed 0.1% by weight in homogeneous material)

(3) MSL, Peak Temp. - The Moisture Sensitivity Level rating according to the JEDEC industry standard classifications, and peak solder temperature.

(4) There may be additional marking, which relates to the logo, the lot trace code information, or the environmental category on the device.

(5) Multiple Device Markings will be inside parentheses. Only one Device Marking contained in parentheses and separated by a "~" will appear on a device. If a line is indented then it is a continuation of the previous line and the two combined represent the entire Device Marking for that device.

(6) Lead/Ball Finish - Orderable Devices may have multiple material finish options. Finish options are separated by a vertical ruled line. Lead/Ball Finish values may wrap to two lines if the finish value exceeds the maximum column width.

Important Information and Disclaimer: The information provided on this page represents TI's knowledge and belief as of the date that it is provided. TI bases its knowledge and belief on information provided by third parties, and makes no representation or warranty as to the accuracy of such information. Efforts are underway to better integrate information from third parties. TI has taken and continues to take reasonable steps to provide representative and accurate information but may not have conducted destructive testing or chemical analysis on incoming materials and chemicals. TI and TI suppliers consider certain information to be proprietary, and thus CAS numbers and other limited information may not be available for release.

In no event shall TI's liability arising out of such information exceed the total purchase price of the TI part(s) at issue in this document sold by TI to Customer on an annual basis.

OTHER QUALIFIED VERSIONS OF DRV8832 :

- Automotive: [DRV8832-Q1](#)

NOTE: Qualified Version Definitions:

- Automotive - Q100 devices qualified for high-reliability automotive applications targeting zero defects

TAPE AND REEL INFORMATION



QUADRANT ASSIGNMENTS FOR PIN 1 ORIENTATION IN TAPE



*All dimensions are nominal

| Device | Package Type | Package Drawing | Pins | SPQ | Reel Diameter (mm) | Reel Width W1 (mm) | A0 (mm) | B0 (mm) | K0 (mm) | P1 (mm) | W (mm) | Pin1 Quadrant |
|-------------|----------------|-----------------|------|------|--------------------|--------------------|---------|---------|---------|---------|--------|---------------|
| DRV8832DGQR | MSOP-Power PAD | DGQ | 10 | 2500 | 330.0 | 12.4 | 5.3 | 3.4 | 1.4 | 8.0 | 12.0 | Q1 |
| DRV8832DRCR | VSON | DRC | 10 | 3000 | 330.0 | 12.4 | 3.3 | 3.3 | 1.1 | 8.0 | 12.0 | Q2 |
| DRV8832DRCT | VSON | DRC | 10 | 250 | 180.0 | 12.4 | 3.3 | 3.3 | 1.1 | 8.0 | 12.0 | Q2 |

TAPE AND REEL BOX DIMENSIONS

*All dimensions are nominal

| Device | Package Type | Package Drawing | Pins | SPQ | Length (mm) | Width (mm) | Height (mm) |
|-------------|---------------|-----------------|------|------|-------------|------------|-------------|
| DRV8832DGQR | MSOP-PowerPAD | DGQ | 10 | 2500 | 367.0 | 367.0 | 35.0 |
| DRV8832DRCR | VSON | DRC | 10 | 3000 | 367.0 | 367.0 | 35.0 |
| DRV8832DRCT | VSON | DRC | 10 | 250 | 210.0 | 185.0 | 35.0 |

DGQ (S-PDSO-G10)

PowerPAD™ PLASTIC SMALL OUTLINE

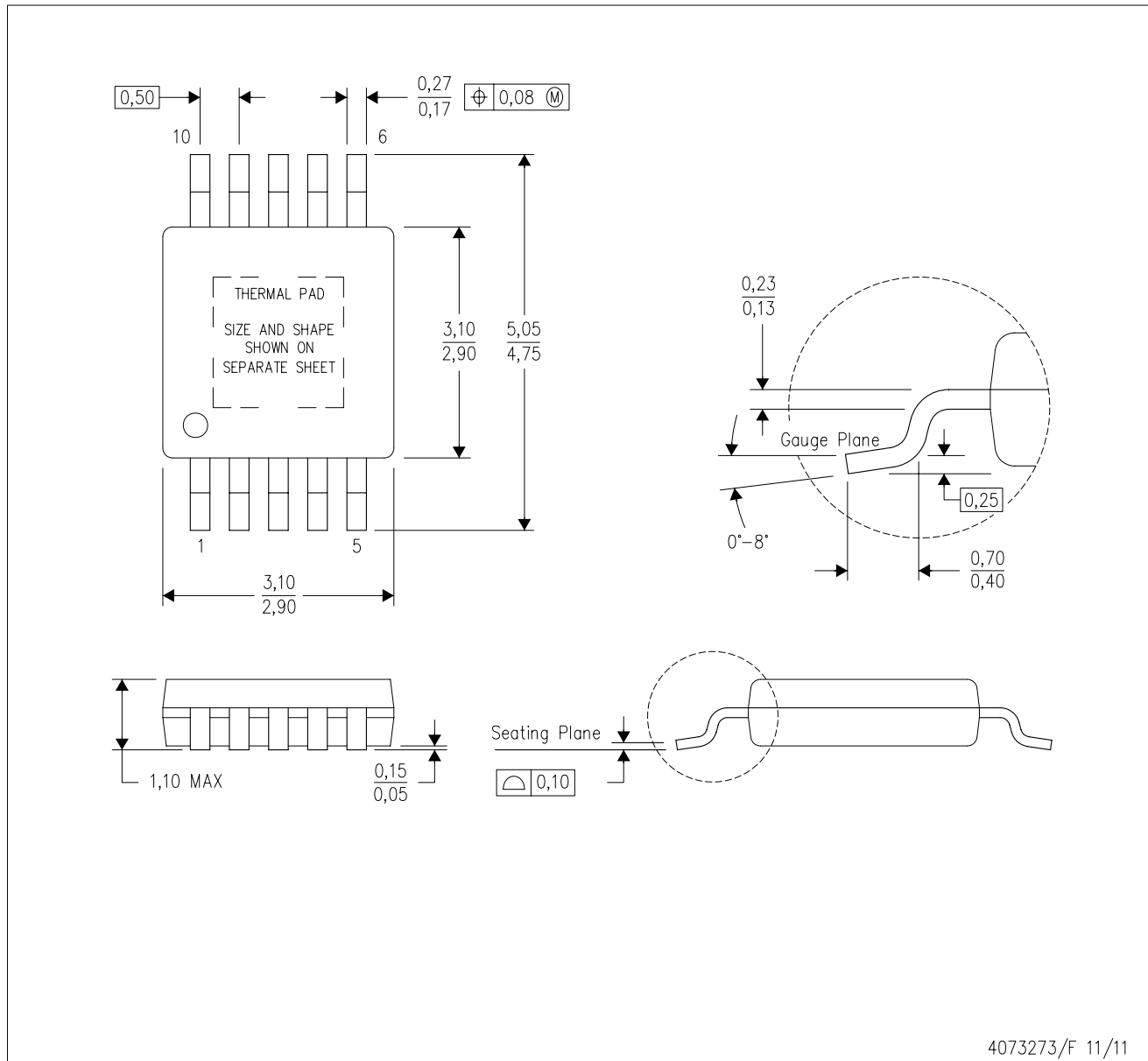

- NOTES:
- A. All linear dimensions are in millimeters.
 - B. This drawing is subject to change without notice.
 - C. Body dimensions do not include mold flash or protrusion not to exceed 0,15.
 - D. This package is designed to be soldered to a thermal pad on the board. Refer to Technical Brief, PowerPad Thermally Enhanced Package, Texas Instruments Literature No. SLMA002 for information regarding recommended board layout. This document is available at www.ti.com <<http://www.ti.com>>.
 - E. See the additional figure in the Product Data Sheet for details regarding the exposed thermal pad features and dimensions.
 - F. Falls within JEDEC MO-187 variation BA-T.

PowerPAD is a trademark of Texas Instruments.

DGQ (S-PDSO-G10)

PowerPAD™ PLASTIC SMALL OUTLINE

THERMAL INFORMATION

This PowerPAD™ package incorporates an exposed thermal pad that is designed to be attached to a printed circuit board (PCB). The thermal pad must be soldered directly to the PCB. After soldering, the PCB can be used as a heatsink. In addition, through the use of thermal vias, the thermal pad can be attached directly to the appropriate copper plane shown in the electrical schematic for the device, or alternatively, can be attached to a special heatsink structure designed into the PCB. This design optimizes the heat transfer from the integrated circuit (IC).

For additional information on the PowerPAD package and how to take advantage of its heat dissipating abilities, refer to Technical Brief, PowerPAD Thermally Enhanced Package, Texas Instruments Literature No. SLMA002 and Application Brief, PowerPAD Made Easy, Texas Instruments Literature No. SLMA004. Both documents are available at www.ti.com.

The exposed thermal pad dimensions for this package are shown in the following illustration.

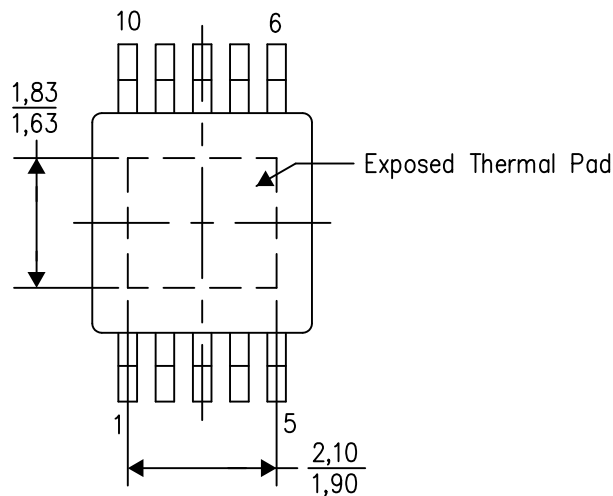

Top View

Exposed Thermal Pad Dimensions

4206324-6/H 12/14

NOTE: A. All linear dimensions are in millimeters

PowerPAD is a trademark of Texas Instruments

GENERIC PACKAGE VIEW

DRC 10

VSON - 1 mm max height

PLASTIC SMALL OUTLINE - NO LEAD

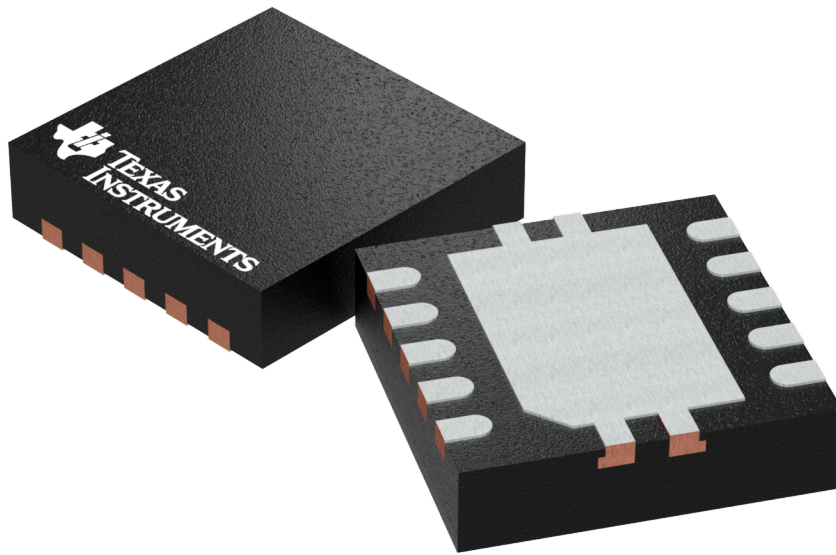

Images above are just a representation of the package family, actual package may vary.
Refer to the product data sheet for package details.

4204102-3/M

EXAMPLE BOARD LAYOUT

DRC0010J

VSON - 1 mm max height

PLASTIC SMALL OUTLINE - NO LEAD



LAND PATTERN EXAMPLE
EXPOSED METAL SHOWN
SCALE:20X



SOLDER MASK DETAILS

4218878/B 07/2018

NOTES: (continued)

4. This package is designed to be soldered to a thermal pad on the board. For more information, see Texas Instruments literature number SLUA271 (www.ti.com/lit/slua271).
5. Vias are optional depending on application, refer to device data sheet. If any vias are implemented, refer to their locations shown on this view. It is recommended that vias under paste be filled, plugged or tented.

EXAMPLE STENCIL DESIGN

DRC0010J

VSON - 1 mm max height

PLASTIC SMALL OUTLINE - NO LEAD

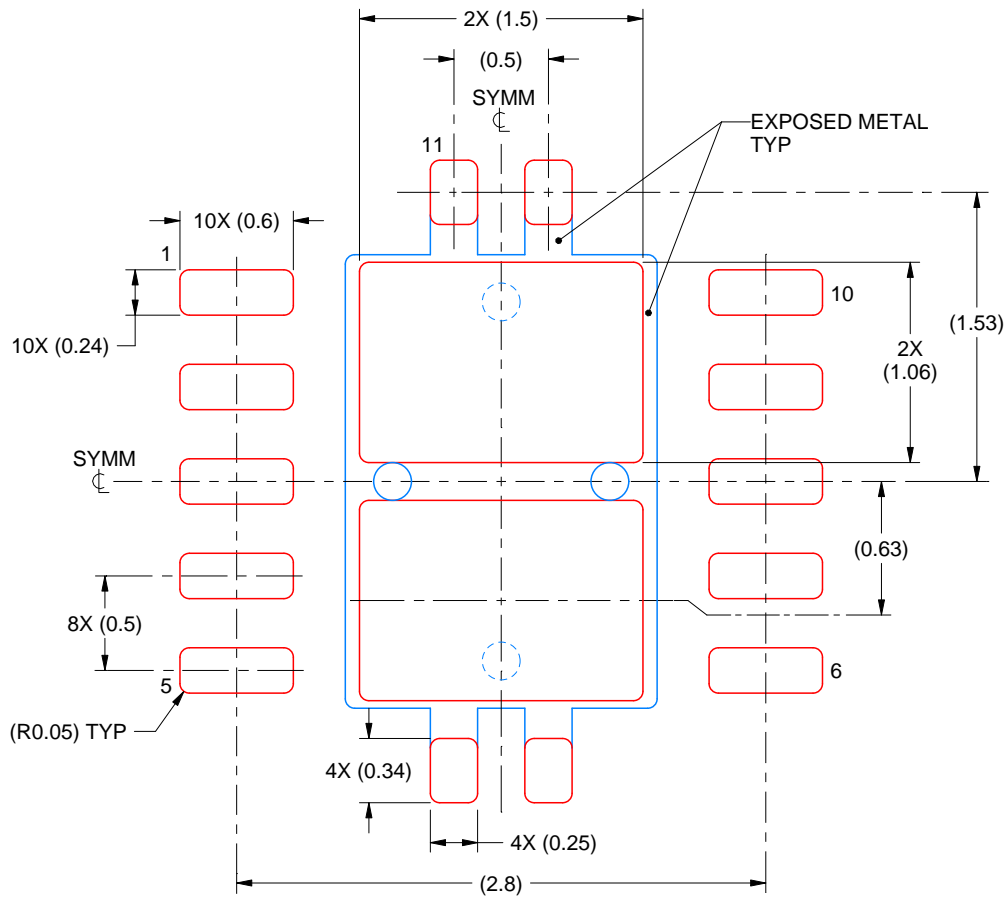

SOLDER PASTE EXAMPLE
BASED ON 0.125 mm THICK STENCIL

EXPOSED PAD 11:
80% PRINTED SOLDER COVERAGE BY AREA
SCALE:25X

4218878/B 07/2018

NOTES: (continued)

6. Laser cutting apertures with trapezoidal walls and rounded corners may offer better paste release. IPC-7525 may have alternate design recommendations.

IMPORTANT NOTICE AND DISCLAIMER

TI PROVIDES TECHNICAL AND RELIABILITY DATA (INCLUDING DATASHEETS), DESIGN RESOURCES (INCLUDING REFERENCE DESIGNS), APPLICATION OR OTHER DESIGN ADVICE, WEB TOOLS, SAFETY INFORMATION, AND OTHER RESOURCES "AS IS" AND WITH ALL FAULTS, AND DISCLAIMS ALL WARRANTIES, EXPRESS AND IMPLIED, INCLUDING WITHOUT LIMITATION ANY IMPLIED WARRANTIES OF MERCHANTABILITY, FITNESS FOR A PARTICULAR PURPOSE OR NON-INFRINGEMENT OF THIRD PARTY INTELLECTUAL PROPERTY RIGHTS.

These resources are intended for skilled developers designing with TI products. You are solely responsible for (1) selecting the appropriate TI products for your application, (2) designing, validating and testing your application, and (3) ensuring your application meets applicable standards, and any other safety, security, or other requirements. These resources are subject to change without notice. TI grants you permission to use these resources only for development of an application that uses the TI products described in the resource. Other reproduction and display of these resources is prohibited. No license is granted to any other TI intellectual property right or to any third party intellectual property right. TI disclaims responsibility for, and you will fully indemnify TI and its representatives against, any claims, damages, costs, losses, and liabilities arising out of your use of these resources.

TI's products are provided subject to TI's Terms of Sale (www.ti.com/legal/termsofsale.html) or other applicable terms available either on ti.com or provided in conjunction with such TI products. TI's provision of these resources does not expand or otherwise alter TI's applicable warranties or warranty disclaimers for TI products.

Mailing Address: Texas Instruments, Post Office Box 655303, Dallas, Texas 75265
Copyright © 2019, Texas Instruments Incorporated

Looking for pricing, stock, or lifecycle information?

Click below to explore more details on WIN SOURCE:

 [View DRV8832DRCT on WIN SOURCE](#)

 [Texas Instruments](#) Information

Optimize Your Supply Chain with WIN SOURCE Solutions

-  Global Sourcing Solution
-  Obsolete Management
-  Cost Control Management
-  Shortage Management
-  Alternative Solution
-  Excess Inventory Management