



**THE DATASHEET OF  
74HC594D,118**



# 74HC594; 74HCT594

## 8-bit shift register with output register

Rev. 4 — 25 February 2016

Product data sheet

### 1. General description

---

The 74HC594; 74HCT594 is an 8-bit serial-in/serial or parallel-out shift register with a storage register. Separate clock and reset inputs are provided on both shift and storage registers. The device features a serial input (DS) and a serial output (Q7S) to enable cascading. Data is shifted on the LOW-to-HIGH transitions of the SHCP input, and the data in the shift register is transferred to the storage register on a LOW-to-HIGH transition of the STCP input. If both clocks are connected together, the shift register will always be one clock pulse ahead of the storage register. A LOW level on one of the two register reset pins ( $\overline{\text{SHR}}$  and  $\overline{\text{STR}}$ ) will clear the corresponding register. Inputs include clamp diodes. This enables the use of current limiting resistors to interface inputs to voltages in excess of  $V_{CC}$ .

### 2. Features and benefits

---

- Synchronous serial input and output
- Complies with JEDEC standard No.7A
- 8-bit parallel output
- Shift and storage registers have independent direct clear and clocks
- Independent clocks for shift and storage registers
- 100 MHz (typical)
- Input levels:
  - ◆ For 74HC594: CMOS level
  - ◆ For 74HCT594: TTL level
- Multiple package options
- Specified from  $-40\text{ }^{\circ}\text{C}$  to  $+85\text{ }^{\circ}\text{C}$  and from  $-40\text{ }^{\circ}\text{C}$  to  $+125\text{ }^{\circ}\text{C}$

### 3. Applications

---

- Serial-to parallel data conversion
- Remote control holding register

## 4. Ordering information

Table 1. Ordering information

Type number	Package			Version
	Temperature range	Name	Description	
74HC594D	-40 °C to +125 °C	SO16	plastic small outline package; 16 leads; body width 3.9 mm	SOT109-1
74HCT594D				
74HC594DB	-40 °C to +125 °C	SSOP16	plastic shrink small outline package; 16 leads; body width 5.3 mm	SOT338-1
74HCT594DB				

## 5. Functional diagram

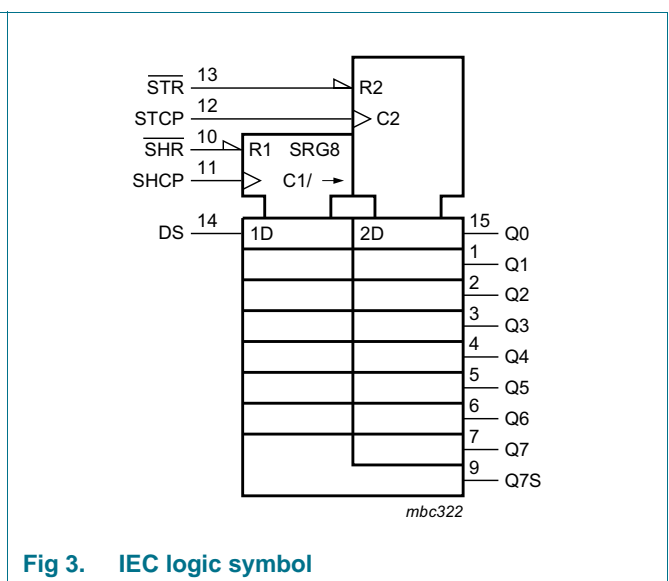
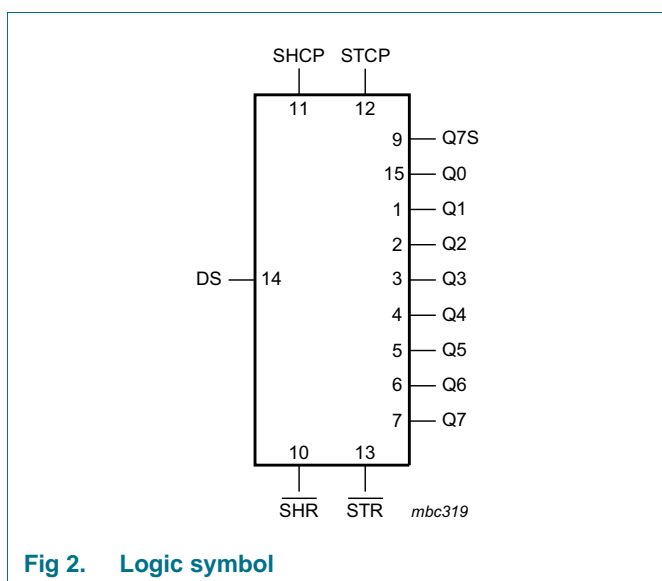
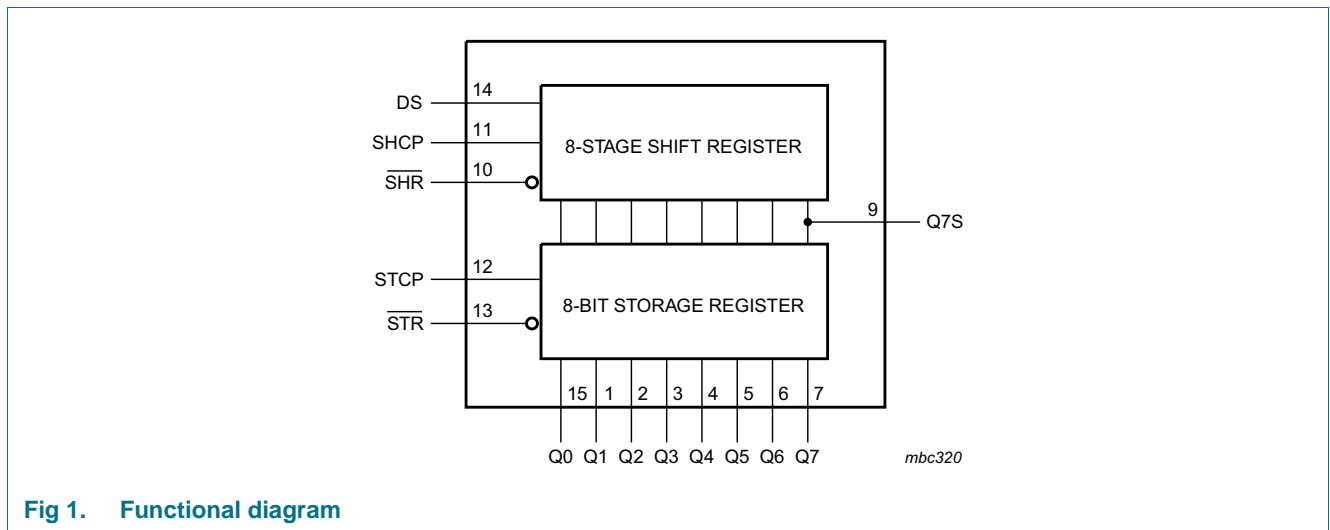



## 6. Pinning information

### 6.1 Pinning

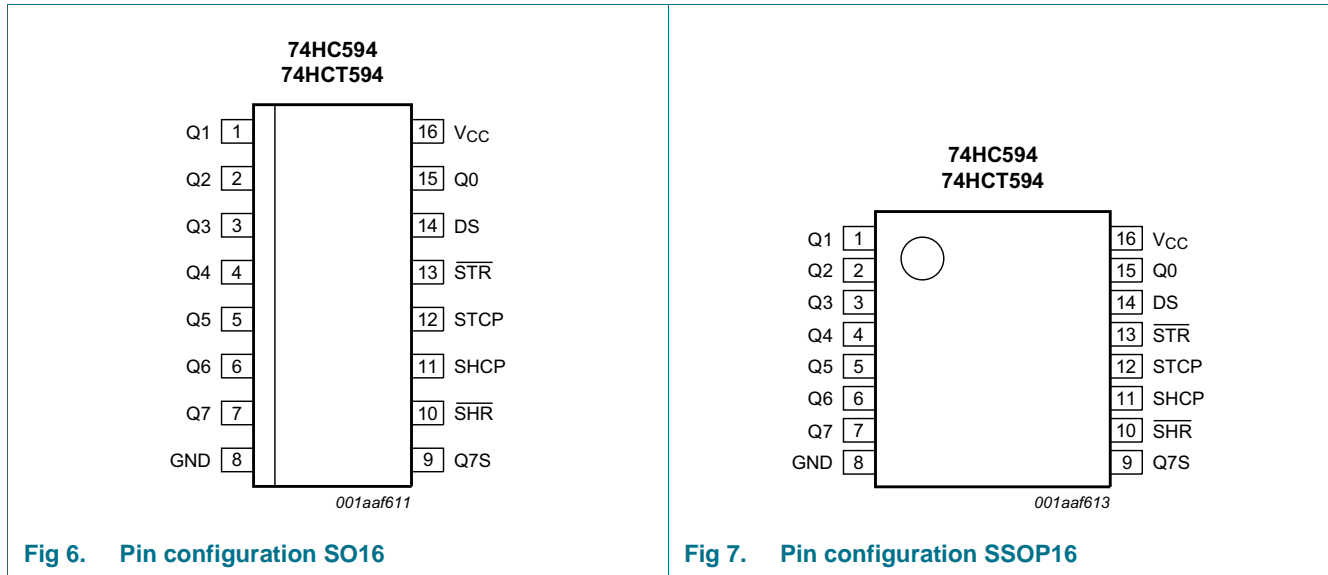

### 6.2 Pin description

**Table 2. Pin description**

Symbol	Pin	Description
Q0, Q1, Q2, Q3, Q4, Q5, Q6, Q7	15, 1, 2, 3, 4, 5, 6, 7	parallel data output
GND	8	ground (0 V)
Q7S	9	serial data output
SHR	10	shift register reset (active LOW)
SHCP	11	shift register clock input
STCP	12	storage register clock input
STR	13	storage register reset (active LOW)
DS	14	serial data input
V <sub>CC</sub>	16	supply voltage

## 7. Functional description

Table 3. Function table<sup>[1]</sup>

Function	Input				
	SHR	STR	SHCP	STCP	DS
Clear shift register	L	X	X	X	X
Clear storage register	X	L	X	X	X
Load DS into shift register stage 0, advance previous stage data to the next stage	H	X	↑	X	H or L
Transfer shift register data to storage register and outputs Qn	X	H	X	↑	X
Shift register one count pulse ahead of storage register	H	H	↑	↑	X

- [1] H = HIGH voltage level;  
 L = LOW voltage level;  
 ↑ = LOW-to-HIGH transition;  
 X = don't care.

## 8. Limiting values

Table 4. Limiting values

In accordance with the Absolute Maximum Rating System (IEC 60134). Voltages are referenced to GND (ground = 0 V).

Symbol	Parameter	Conditions	Min	Max	Unit
$V_{CC}$	supply voltage		-0.5	+7.0	V
$I_{IK}$	input clamping current	$V_I < -0.5\text{ V}$ or $V_I > V_{CC} + 0.5\text{ V}$ <sup>[1]</sup>	-	±20	mA
$I_{OK}$	output clamping current	$V_O < -0.5\text{ V}$ or $V_O > V_{CC} + 0.5\text{ V}$ <sup>[1]</sup>	-	±20	mA
$I_O$	output current	$V_O = -0.5\text{ V}$ to $V_{CC} + 0.5\text{ V}$			
		Serial data output Q7S	-	±25	mA
		Parallel data output	-	±35	mA
$I_{CC}$	supply current	Serial data output Q7S	-	50	mA
		Parallel data output	-	70	mA
$I_{GND}$	ground current	Serial data output Q7S	-	-50	mA
		Parallel data output	-	-70	mA
$T_{stg}$	storage temperature		-65	+150	°C
$P_{tot}$	total power dissipation	$T_{amb} = -40\text{ °C}$ to $+125\text{ °C}$ <sup>[2]</sup>	-	500	mW

- [1] The input and output voltage ratings may be exceeded if the input and output current ratings are observed.  
 [2] For SO16 packages: above 70 °C the value of  $P_{tot}$  derates linearly with 8 mW/K.  
 For SSOP16 packages: above 60 °C the value of  $P_{tot}$  derates linearly with 5.5 mW/K.

## 9. Recommended operating conditions

**Table 5. Recommended operating conditions**

Voltages are referenced to GND (ground = 0 V)

Symbol	Parameter	Conditions	74HC594			74HCT594			Unit
			Min	Typ	Max	Min	Typ	Max	
$V_{CC}$	supply voltage		2.0	5.0	6.0	4.5	5.0	5.5	V
$V_I$	input voltage		0	-	$V_{CC}$	0	-	$V_{CC}$	V
$V_O$	output voltage		0	-	$V_{CC}$	0	-	$V_{CC}$	V
$T_{amb}$	ambient temperature		-40	-	+125	-40	-	+125	°C
$\Delta t/\Delta V$	input transition rise and fall rate	$V_{CC} = 2.0\text{ V}$	-	-	625	-	-	-	ns/V
		$V_{CC} = 4.5\text{ V}$	-	1.67	139	-	1.67	139	ns/V
		$V_{CC} = 6.0\text{ V}$	-	-	83	-	-	-	ns/V

## 10. Static characteristics

**Table 6. Static characteristics type 74HC594**

At recommended operating conditions; voltages are referenced to GND (ground = 0 V).

Symbol	Parameter	Conditions	Min	Typ	Max	Unit
<b><math>T_{amb} = 25\text{ °C}</math></b>						
$V_{IH}$	HIGH-level input voltage	$V_{CC} = 2.0\text{ V}$	1.5	1.2	-	V
		$V_{CC} = 4.5\text{ V}$	3.15	2.4	-	V
		$V_{CC} = 6.0\text{ V}$	4.2	3.2	-	V
$V_{IL}$	LOW-level input voltage	$V_{CC} = 2.0\text{ V}$	-	0.8	0.5	V
		$V_{CC} = 4.5\text{ V}$	-	2.1	1.35	V
		$V_{CC} = 6.0\text{ V}$	-	2.8	1.8	V
$V_{OH}$	HIGH-level output voltage	$V_I = V_{IH}$ or $V_{IL}$				
		Serial data output Q7S				
		$I_O = -4.0\text{ mA}$ ; $V_{CC} = 4.5\text{ V}$	3.98	4.32	-	V
		$I_O = -5.2\text{ mA}$ ; $V_{CC} = 6.0\text{ V}$	5.48	5.81	-	V
		Parallel data outputs				
		$I_O = -6.0\text{ mA}$ ; $V_{CC} = 4.5\text{ V}$	3.98	4.32	-	V
$V_{OL}$	LOW-level output voltage	$V_I = V_{IH}$ or $V_{IL}$				
		Serial data output Q7S				
		$I_O = 4.0\text{ mA}$ ; $V_{CC} = 4.5\text{ V}$	-	0.15	0.26	V
		$I_O = 5.2\text{ mA}$ ; $V_{CC} = 6.0\text{ V}$	-	0.16	0.26	V
		Parallel data outputs				
		$I_O = 6.0\text{ mA}$ ; $V_{CC} = 4.5\text{ V}$	-	0.15	0.26	V
$I_I$	input leakage current	$V_I = V_{CC}$ or GND; $V_{CC} = 6.0\text{ V}$	-	-	$\pm 0.1$	$\mu\text{A}$
		$V_I = V_{CC}$ or GND; $I_O = 0\text{ A}$ ; $V_{CC} = 6.0\text{ V}$	-	-	8.0	$\mu\text{A}$
$C_i$	input capacitance		-	3.5	-	pF

**Table 6.** Static characteristics type 74HC594 ...continued

At recommended operating conditions; voltages are referenced to GND (ground = 0 V).

Symbol	Parameter	Conditions	Min	Typ	Max	Unit
<b>T<sub>amb</sub> = -40 °C to +85 °C</b>						
V <sub>IH</sub>	HIGH-level input voltage	V <sub>CC</sub> = 2.0 V	1.5	-	-	V
		V <sub>CC</sub> = 4.5 V	3.15	-	-	V
		V <sub>CC</sub> = 6.0 V	4.2	-	-	V
V <sub>IL</sub>	LOW-level input voltage	V <sub>CC</sub> = 2.0 V	-	-	0.5	V
		V <sub>CC</sub> = 4.5 V	-	-	1.35	V
		V <sub>CC</sub> = 6.0 V	-	-	1.8	V
V <sub>OH</sub>	HIGH-level output voltage	V <sub>I</sub> = V <sub>IH</sub> or V <sub>IL</sub>				
		Serial data output Q7S				
		I <sub>O</sub> = -4.0 mA; V <sub>CC</sub> = 4.5 V	3.84	-	-	V
		I <sub>O</sub> = -5.2 mA; V <sub>CC</sub> = 6.0 V	5.34	-	-	V
		Parallel data outputs				
		I <sub>O</sub> = -6.0 mA; V <sub>CC</sub> = 4.5 V	3.84	-	-	V
V <sub>OL</sub>	LOW-level output voltage	V <sub>I</sub> = V <sub>IH</sub> or V <sub>IL</sub>				
		Serial data output Q7S				
		I <sub>O</sub> = 4.0 mA; V <sub>CC</sub> = 4.5 V	-	-	0.33	V
		I <sub>O</sub> = 5.2 mA; V <sub>CC</sub> = 6.0 V	-	-	0.33	V
		Parallel data outputs				
		I <sub>O</sub> = 6.0 mA; V <sub>CC</sub> = 4.5 V	-	-	0.33	V
I <sub>I</sub>	input leakage current	V <sub>I</sub> = V <sub>CC</sub> or GND; V <sub>CC</sub> = 6.0 V	-	-	±1.0	μA
I <sub>CC</sub>	supply current	V <sub>I</sub> = V <sub>CC</sub> or GND; I <sub>O</sub> = 0 A; V <sub>CC</sub> = 6.0 V	-	-	80	μA
<b>T<sub>amb</sub> = -40 °C to +125 °C</b>						
V <sub>IH</sub>	HIGH-level input voltage	V <sub>CC</sub> = 2.0 V	1.5	-	-	V
		V <sub>CC</sub> = 4.5 V	3.15	-	-	V
		V <sub>CC</sub> = 6.0 V	4.2	-	-	V
V <sub>IL</sub>	LOW-level input voltage	V <sub>CC</sub> = 2.0 V	-	-	0.5	V
		V <sub>CC</sub> = 4.5 V	-	-	1.35	V
		V <sub>CC</sub> = 6.0 V	-	-	1.8	V
V <sub>OH</sub>	HIGH-level output voltage	V <sub>I</sub> = V <sub>IH</sub> or V <sub>IL</sub>				
		Serial data output Q7S				
		I <sub>O</sub> = -4.0 mA; V <sub>CC</sub> = 4.5 V	3.7	-	-	V
		I <sub>O</sub> = -5.2 mA; V <sub>CC</sub> = 6.0 V	5.2	-	-	V
		Parallel data outputs				
		I <sub>O</sub> = -6.0 mA; V <sub>CC</sub> = 4.5 V	3.7	-	-	V
		I <sub>O</sub> = -7.8 mA; V <sub>CC</sub> = 6.0 V	5.2	-	-	V

**Table 6.** Static characteristics type 74HC594 ...continued

At recommended operating conditions; voltages are referenced to GND (ground = 0 V).

Symbol	Parameter	Conditions	Min	Typ	Max	Unit
V <sub>OL</sub>	LOW-level output voltage	V <sub>I</sub> = V <sub>IH</sub> or V <sub>IL</sub>				
		Serial data output Q7S				
		I <sub>O</sub> = 4.0 mA; V <sub>CC</sub> = 4.5 V	-	-	0.4	V
		I <sub>O</sub> = 5.2 mA; V <sub>CC</sub> = 6.0 V	-	-	0.4	V
		Parallel data outputs				
		I <sub>O</sub> = 6.0 mA; V <sub>CC</sub> = 4.5 V	-	-	0.4	V
I <sub>I</sub>	input leakage current	V <sub>I</sub> = V <sub>CC</sub> or GND; V <sub>CC</sub> = 6.0 V	-	-	±1.0	μA
		I <sub>O</sub> = 7.8 mA; V <sub>CC</sub> = 6.0 V	-	-	0.4	V
I <sub>CC</sub>	supply current	V <sub>I</sub> = V <sub>CC</sub> or GND; I <sub>O</sub> = 0 A; V <sub>CC</sub> = 6.0 V	-	-	160	μA

**Table 7.** Static characteristics type 74HCT594

At recommended operating conditions; voltages are referenced to GND (ground = 0 V).

Symbol	Parameter	Conditions	Min	Typ	Max	Unit
<b>T<sub>amb</sub> = 25 °C</b>						
V <sub>IH</sub>	HIGH-level input voltage	V <sub>CC</sub> = 4.5 V to 5.5 V	2.0	1.6	-	V
V <sub>IL</sub>	LOW-level input voltage	V <sub>CC</sub> = 4.5 V to 5.5 V	-	1.2	0.8	V
V <sub>OH</sub>	HIGH-level output voltage	V <sub>I</sub> = V <sub>IH</sub> or V <sub>IL</sub>				
		Serial data output Q7S				
		I <sub>O</sub> = -4.0 mA; V <sub>CC</sub> = 4.5 V	3.98	4.32	-	V
		Parallel data outputs				
V <sub>OL</sub>	LOW-level output voltage	I <sub>O</sub> = -6.0 mA; V <sub>CC</sub> = 4.5 V	3.98	4.32	-	V
		V <sub>I</sub> = V <sub>IH</sub> or V <sub>IL</sub>				
		Serial data output Q7S				
		I <sub>O</sub> = 4.0 mA; V <sub>CC</sub> = 4.5 V	-	0.15	0.26	V
I <sub>I</sub>	input leakage current	V <sub>I</sub> = V <sub>CC</sub> or GND; V <sub>CC</sub> = 5.5 V	-	-	±0.1	μA
		I <sub>O</sub> = 6.0 mA; V <sub>CC</sub> = 4.5 V	-	0.16	0.26	V
I <sub>CC</sub>	supply current	V <sub>I</sub> = V <sub>CC</sub> or GND; I <sub>O</sub> = 0 A; V <sub>CC</sub> = 5.5 V	-	-	8.0	μA
ΔI <sub>CC</sub>	additional supply current	per input pin; V <sub>I</sub> = V <sub>CC</sub> - 2.1 V and other inputs at V <sub>CC</sub> or GND; I <sub>O</sub> = 0 A; V <sub>CC</sub> = 4.5 V to 5.5 V				
		pins $\overline{\text{SHR}}$ , SHCP, STCP, $\overline{\text{STR}}$	-	150	540	μA
		pin DS	-	25	90	μA
C <sub>i</sub>	input capacitance		-	3.5	-	pF

**Table 7. Static characteristics type 74HCT594 ...continued**

At recommended operating conditions; voltages are referenced to GND (ground = 0 V).

Symbol	Parameter	Conditions	Min	Typ	Max	Unit
<b>T<sub>amb</sub> = -40 °C to +85 °C</b>						
V <sub>IH</sub>	HIGH-level input voltage	V <sub>CC</sub> = 4.5 V to 5.5 V	2.0	-	-	V
V <sub>IL</sub>	LOW-level input voltage	V <sub>CC</sub> = 4.5 V to 5.5 V	-	-	0.8	V
V <sub>OH</sub>	HIGH-level output voltage	V <sub>I</sub> = V <sub>IH</sub> or V <sub>IL</sub>				
		Serial data output Q7S				
		I <sub>O</sub> = -4.0 mA; V <sub>CC</sub> = 4.5 V	3.84	-	-	V
		Parallel data outputs				
		I <sub>O</sub> = -6.0 mA; V <sub>CC</sub> = 4.5 V	3.84	-	-	V
V <sub>OL</sub>	LOW-level output voltage	V <sub>I</sub> = V <sub>IH</sub> or V <sub>IL</sub>				
		Serial data output				
		I <sub>O</sub> = 4.0 mA; V <sub>CC</sub> = 4.5 V	-	-	0.33	V
		Parallel data outputs				
		I <sub>O</sub> = 6.0 mA; V <sub>CC</sub> = 4.5 V	-	-	0.33	V
I <sub>I</sub>	input leakage current	V <sub>I</sub> = V <sub>CC</sub> or GND; V <sub>CC</sub> = 5.5 V	-	-	±1.0	μA
I <sub>CC</sub>	supply current	V <sub>I</sub> = V <sub>CC</sub> or GND; I <sub>O</sub> = 0 A; V <sub>CC</sub> = 5.5 V	-	-	80	μA
ΔI <sub>CC</sub>	additional supply current	per input pin; V <sub>I</sub> = V <sub>CC</sub> - 2.1 V and other inputs at V <sub>CC</sub> or GND; I <sub>O</sub> = 0 A; V <sub>CC</sub> = 4.5 V to 5.5 V				
		pins $\overline{\text{SHR}}$ , SHCP, STCP, $\overline{\text{STR}}$	-	-	675	μA
		pin DS	-	-	112.5	μA
<b>T<sub>amb</sub> = -40 °C to +125 °C</b>						
V <sub>IH</sub>	HIGH-level input voltage	V <sub>CC</sub> = 4.5 V to 5.5 V	2.0	-	-	V
V <sub>IL</sub>	LOW-level input voltage	V <sub>CC</sub> = 4.5 V to 5.5 V	-	-	0.8	V
V <sub>OH</sub>	HIGH-level output voltage	V <sub>I</sub> = V <sub>IH</sub> or V <sub>IL</sub>				
		Serial data output Q7S				
		I <sub>O</sub> = -4.0 mA; V <sub>CC</sub> = 4.5 V	3.7	-	-	V
		Parallel data outputs				
		I <sub>O</sub> = -6.0 mA; V <sub>CC</sub> = 4.5 V	3.7	-	-	V
V <sub>OL</sub>	LOW-level output voltage	V <sub>I</sub> = V <sub>IH</sub> or V <sub>IL</sub>				
		Serial data output Q7S				
		I <sub>O</sub> = 4.0 mA; V <sub>CC</sub> = 4.5 V	-	-	0.4	V
		Parallel data outputs				
		I <sub>O</sub> = 6.0 mA; V <sub>CC</sub> = 4.5 V	-	-	0.4	V
I <sub>I</sub>	input leakage current	V <sub>I</sub> = V <sub>CC</sub> or GND; V <sub>CC</sub> = 5.5 V	-	-	±1.0	μA
I <sub>CC</sub>	supply current	V <sub>I</sub> = V <sub>CC</sub> or GND; I <sub>O</sub> = 0 A; V <sub>CC</sub> = 5.5 V	-	-	160	μA
ΔI <sub>CC</sub>	additional supply current	per input pin; V <sub>I</sub> = V <sub>CC</sub> - 2.1 V and other inputs at V <sub>CC</sub> or GND; I <sub>O</sub> = 0 A; V <sub>CC</sub> = 4.5 V to 5.5 V				
		pins $\overline{\text{SHR}}$ , SHCP, STCP, $\overline{\text{STR}}$	-	-	735	μA
		pin DS	-	-	122.5	μA

## 11. Dynamic characteristics

**Table 8. Dynamic characteristics type 74HC594**

$GND = 0\text{ V}$ ;  $t_r = t_f = 6\text{ ns}$ ;  $C_L = 50\text{ pF}$ ; see [Figure 14](#).

Symbol	Parameter	Conditions	25 °C			–40 °C to +85 °C		–40 °C to +125 °C		Unit
			Min	Typ	Max	Min	Max	Min	Max	
$t_{pd}$	propagation delay	SHCP to Q7S; see <a href="#">Figure 8</a> <sup>[1]</sup>								
		$V_{CC} = 2.0\text{ V}$	-	44	150	-	185	-	225	ns
		$V_{CC} = 4.5\text{ V}$	-	16	30	-	37	-	45	ns
		$V_{CC} = 5.0\text{ V}$ ; $C_L = 15\text{ pF}$	-	13	-	-	-	-	-	ns
		$V_{CC} = 6.0\text{ V}$	-	14	26	-	31	-	38	ns
		STCP to Qn; see <a href="#">Figure 9</a>								
		$V_{CC} = 2.0\text{ V}$	-	44	150	-	185	-	225	ns
		$V_{CC} = 4.5\text{ V}$	-	16	30	-	37	-	45	ns
$t_{PHL}$	HIGH to LOW propagation delay	$\overline{\text{SHR}}$ to Q7S; see <a href="#">Figure 12</a>								
		$V_{CC} = 2.0\text{ V}$	-	39	150	-	185	-	225	ns
		$V_{CC} = 4.5\text{ V}$	-	14	30	-	37	-	45	ns
		$V_{CC} = 5.0\text{ V}$ ; $C_L = 15\text{ pF}$	-	11	-	-	-	-	-	ns
		$V_{CC} = 6.0\text{ V}$	-	12	26	-	31	-	38	ns
		$\overline{\text{STR}}$ to Qn; see <a href="#">Figure 13</a>								
		$V_{CC} = 2.0\text{ V}$	-	39	125	-	155	-	185	ns
		$V_{CC} = 4.5\text{ V}$	-	14	25	-	31	-	37	ns
$t_{THL}$	HIGH to LOW output transition time	Q7S; see <a href="#">Figure 8</a>								
		$V_{CC} = 2.0\text{ V}$	-	19	75	-	95	-	110	ns
		$V_{CC} = 4.5\text{ V}$	-	7	15	-	19	-	22	ns
		$V_{CC} = 6.0\text{ V}$	-	6	13	-	16	-	19	ns
		Qn								
		$V_{CC} = 2.0\text{ V}$	-	14	60	-	75	-	90	ns
		$V_{CC} = 4.5\text{ V}$	-	5	12	-	15	-	18	ns
		$V_{CC} = 6.0\text{ V}$	-	4	10	-	13	-	15	ns
$t_{TLH}$	LOW to HIGH output transition time	Q7S; see <a href="#">Figure 8</a>								
		$V_{CC} = 2.0\text{ V}$	-	19	75	-	95	-	110	ns
		$V_{CC} = 4.5\text{ V}$	-	7	15	-	19	-	22	ns
		$V_{CC} = 6.0\text{ V}$	-	6	13	-	16	-	19	ns
		Qn								
		$V_{CC} = 2.0\text{ V}$	-	14	60	-	75	-	90	ns
		$V_{CC} = 4.5\text{ V}$	-	5	12	-	15	-	18	ns
		$V_{CC} = 6.0\text{ V}$	-	4	10	-	13	-	15	ns

Table 8. Dynamic characteristics type 74HC594 ...continued

GND = 0 V;  $t_r = t_f = 6$  ns;  $C_L = 50$  pF; see [Figure 14](#).

Symbol	Parameter	Conditions	25 °C			−40 °C to +85 °C		−40 °C to +125 °C		Unit
			Min	Typ	Max	Min	Max	Min	Max	
$t_w$	pulse width	SHCP (HIGH or LOW); see <a href="#">Figure 8</a>								
		$V_{CC} = 2.0$ V	80	10	-	100	-	120	-	ns
		$V_{CC} = 4.5$ V	16	4	-	20	-	24	-	ns
		$V_{CC} = 6.0$ V	14	3	-	17	-	20	-	ns
		STCP (HIGH or LOW); see <a href="#">Figure 9</a>								
		$V_{CC} = 2.0$ V	80	10	-	100	-	120	-	ns
		$V_{CC} = 4.5$ V	16	4	-	20	-	24	-	ns
		$V_{CC} = 6.0$ V	14	3	-	17	-	20	-	ns
		SHR and STR (HIGH or LOW); see <a href="#">Figure 12</a> and <a href="#">Figure 13</a>								
		$V_{CC} = 2.0$ V	80	14	-	100	-	120	-	ns
		$V_{CC} = 4.5$ V	16	5	-	20	-	24	-	ns
		$V_{CC} = 6.0$ V	14	4	-	17	-	20	-	ns
$t_{su}$	set-up time	DS to SHCP; see <a href="#">Figure 10</a>								
		$V_{CC} = 2.0$ V	100	10	-	125	-	150	-	ns
		$V_{CC} = 4.5$ V	20	4	-	25	-	30	-	ns
		$V_{CC} = 6.0$ V	17	3	-	21	-	26	-	ns
		SHR to STCP; see <a href="#">Figure 11</a>								
		$V_{CC} = 2.0$ V	100	14	-	125	-	150	-	ns
		$V_{CC} = 4.5$ V	20	5	-	25	-	30	-	ns
		$V_{CC} = 6.0$ V	17	4	-	21	-	26	-	ns
		SHCP to STCP; see <a href="#">Figure 9</a>								
		$V_{CC} = 2.0$ V	100	17	-	125	-	150	-	ns
		$V_{CC} = 4.5$ V	20	6	-	25	-	30	-	ns
		$V_{CC} = 6.0$ V	17	5	-	21	-	26	-	ns
$t_h$	hold time	DS to SHCP; see <a href="#">Figure 10</a>								
		$V_{CC} = 2.0$ V	25	−8	-	30	-	35	-	ns
		$V_{CC} = 4.5$ V	5	−3	-	6	-	7	-	ns
		$V_{CC} = 6.0$ V	4	−2	-	5	-	6	-	ns
$t_{rec}$	recovery time	SHR to SHCP and STR to STCP; see <a href="#">Figure 12</a> and <a href="#">Figure 13</a>								
		$V_{CC} = 2.0$ V	50	−14	-	65	-	75	-	ns
		$V_{CC} = 4.5$ V	10	−5	-	13	-	15	-	ns
		$V_{CC} = 6.0$ V	9	−4	-	11	-	13	-	ns

**Table 8.** Dynamic characteristics type 74HC594 ...continuedGND = 0 V;  $t_r = t_f = 6$  ns;  $C_L = 50$  pF; see [Figure 14](#).

Symbol	Parameter	Conditions	25 °C			-40 °C to +85 °C		-40 °C to +125 °C		Unit
			Min	Typ	Max	Min	Max	Min	Max	
$f_{\max}$	maximum frequency	SHCP or STCP; see <a href="#">Figure 8</a> and <a href="#">Figure 9</a>								
		$V_{CC} = 2.0$ V	6.0	30	-	4.8	-	4.0	-	MHz
		$V_{CC} = 4.5$ V	30	92	-	24	-	20	-	MHz
		$V_{CC} = 5.0$ V; $C_L = 15$ pF	-	100	-	-	-	-	-	MHz
		$V_{CC} = 6.0$ V	35	109	-	28	-	24	-	MHz
$C_{PD}$	power dissipation capacitance	$V_I = \text{GND to } V_{CC}$ ; $V_{CC} = 5$ V; $f_i = 1$ MHz <a href="#">[2]</a>	-	84	-	-	-	-	-	pF

[1]  $t_{pd}$  is the same as  $t_{PHL}$  and  $t_{PLH}$ .[2]  $C_{PD}$  is used to determine the dynamic power dissipation ( $P_D$  in  $\mu\text{W}$ ):

$$P_D = C_{PD} \times V_{CC}^2 \times f_i \times N + \sum(C_L \times V_{CC}^2 \times f_o) \text{ where:}$$

 $f_i$  = input frequency in MHz; $f_o$  = output frequency in MHz; $C_L$  = output load capacitance in pF; $V_{CC}$  = supply voltage in V;

N = number of inputs switching;

 $\sum(C_L \times V_{CC}^2 \times f_o)$  = sum of outputs.**Table 9.** Dynamic characteristics type 74HCT594GND = 0 V;  $V_{CC} = 4.5$  V;  $t_r = t_f = 6$  ns;  $C_L = 50$  pF; see [Figure 14](#).

Symbol	Parameter	Conditions	25 °C			-40 °C to +85 °C		-40 °C to +125 °C		Unit
			Min	Typ	Max	Min	Max	Min	Max	
$t_{pd}$	propagation delay	SHCP to Q7S; see <a href="#">Figure 8</a> <a href="#">[1]</a>	-	18	32	-	40	-	48	ns
		$V_{CC} = 5.0$ V; $C_L = 15$ pF	-	15	-	-	-	-	-	ns
		STCP to Qn; see <a href="#">Figure 9</a>	-	18	32	-	40	-	48	ns
		$V_{CC} = 5.0$ V; $C_L = 15$ pF	-	15	-	-	-	-	-	ns
$t_{PHL}$	HIGH to LOW propagation delay	SHR to Q7S; see <a href="#">Figure 12</a>	-	17	30	-	38	-	45	ns
		$V_{CC} = 5.0$ V; $C_L = 15$ pF	-	14	-	-	-	-	-	ns
		STR to Qn; see <a href="#">Figure 13</a>	-	17	30	-	38	-	45	ns
		$V_{CC} = 5.0$ V; $C_L = 15$ pF	-	14	-	-	-	-	-	ns
$t_{THL}$	HIGH to LOW output transition time	Q7S; see <a href="#">Figure 8</a>								
		$V_{CC} = 4.5$ V	-	7	15	-	19	-	22	ns
		Qn								
		$V_{CC} = 4.5$ V	-	5	12	-	15	-	18	ns
$t_{TLH}$	LOW to HIGH output transition time	Q7S; see <a href="#">Figure 8</a>								
		$V_{CC} = 4.5$ V	-	7	15	-	19	-	22	ns
		Qn								
		$V_{CC} = 4.5$ V	-	5	12	-	15	-	18	ns

**Table 9. Dynamic characteristics type 74HCT594 ...continued**  
 $GND = 0\text{ V}$ ;  $V_{CC} = 4.5\text{ V}$ ;  $t_r = t_f = 6\text{ ns}$ ;  $C_L = 50\text{ pF}$ ; see [Figure 14](#).

Symbol	Parameter	Conditions	25 °C			−40 °C to +85 °C		−40 °C to +125 °C		Unit
			Min	Typ	Max	Min	Max	Min	Max	
$t_W$	pulse width	SHCP (HIGH or LOW); see <a href="#">Figure 8</a>	16	4	-	20	-	24	-	ns
		STCP (HIGH or LOW); see <a href="#">Figure 9</a>	16	4	-	20	-	24	-	ns
		SHR and STR (HIGH or LOW); see <a href="#">Figure 12</a> and <a href="#">Figure 13</a>	16	6	-	20	-	24	-	ns
$t_{su}$	set-up time	DS to SHCP; see <a href="#">Figure 10</a>	20	4	-	25	-	30	-	ns
		SHR to STCP; see <a href="#">Figure 11</a>	20	6	-	25	-	30	-	ns
		SHCP to STCP; see <a href="#">Figure 9</a>	20	7	-	25	-	30	-	ns
$t_h$	hold time	DS to SHCP; see <a href="#">Figure 10</a>	5	−3	-	6	-	7	-	ns
$t_{rec}$	recovery time	SHR to SHCP and STR to STCP; see <a href="#">Figure 12</a> and <a href="#">Figure 13</a>	10	−5	-	13	-	15	-	ns
$f_{max}$	maximum frequency	SHCP or STCP; see <a href="#">Figure 8</a> and <a href="#">Figure 9</a>	30	92	-	24	-	20	-	MHz
		$V_{CC} = 5.0\text{ V}$ ; $C_L = 15\text{ pF}$	-	100	-	-	-	-	-	MHz
$C_{PD}$	power dissipation capacitance	$V_I = GND$ to $V_{CC} - 1.5\text{ V}$ ; $V_{CC} = 5\text{ V}$ ; $f_i = 1\text{ MHz}$ <a href="#">[2]</a>	-	89	-	-	-	-	-	pF

[1]  $t_{pd}$  is the same as  $t_{PHL}$  and  $t_{PLH}$ .

[2]  $C_{PD}$  is used to determine the dynamic power dissipation ( $P_D$  in  $\mu\text{W}$ ):

$$P_D = C_{PD} \times V_{CC}^2 \times f_i \times N + \sum(C_L \times V_{CC}^2 \times f_o) \text{ where:}$$

$f_i$  = input frequency in MHz;

$f_o$  = output frequency in MHz;

$C_L$  = output load capacitance in pF;

$V_{CC}$  = supply voltage in V;

$N$  = number of inputs switching;

$\sum(C_L \times V_{CC}^2 \times f_o)$  = sum of outputs.

12. Waveforms

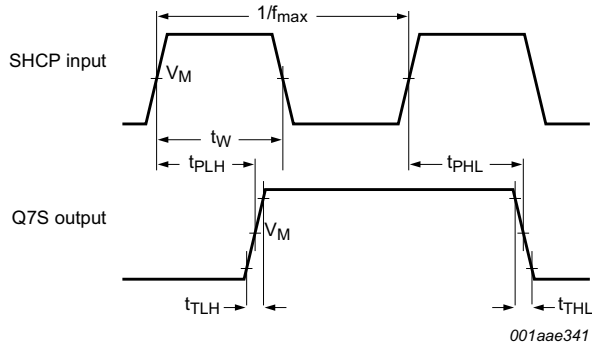

Measurement points are given in [Table 10](#).

$t_{PLH}$  and  $t_{PHL}$  are the same as  $t_{pd}$ .

$t_{TLH}$  = LOW to HIGH output transition time;  $t_{THL}$  = HIGH to LOW output transition time.

**Fig 8. The shift clock (SHCP) to output (Q7S) propagation delays, the shift clock pulse width, the maximum shift clock frequency, and output transition times**

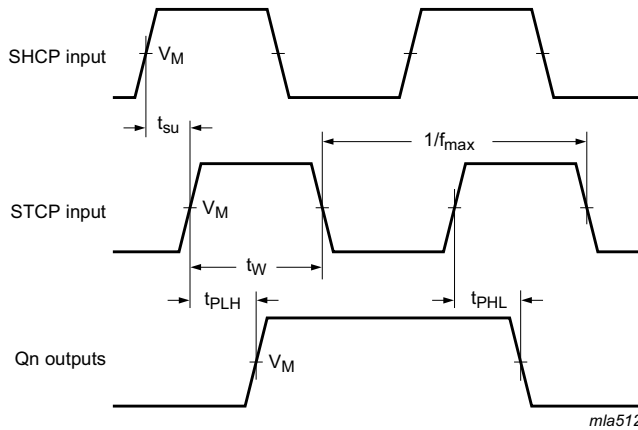

Measurement points are given in [Table 10](#).

$t_{PLH}$  and  $t_{PHL}$  are the same as  $t_{pd}$ .

**Fig 9. The storage clock (STCP) to output (Qn), propagation delays, the storage clock pulse width, the maximum storage clock pulse frequency and the shift clock to storage clock set-up time**

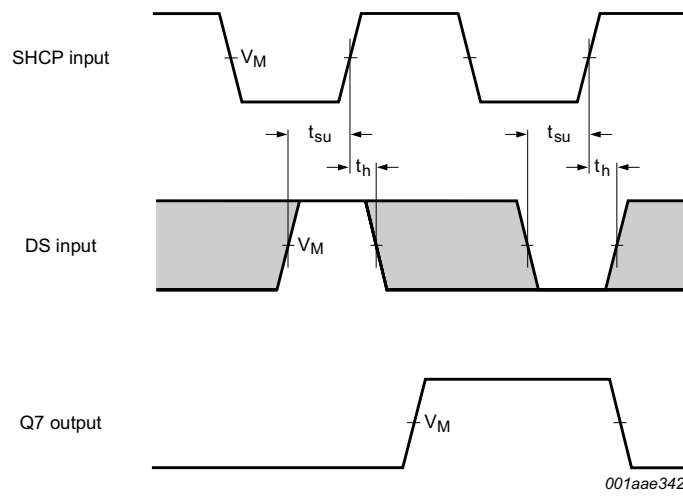

Measurement points are given in [Table 10](#).

The shaded areas indicate when the input is permitted to change for predictable output performance.

**Fig 10. The data set-up time and hold times for DS input to SHCP**

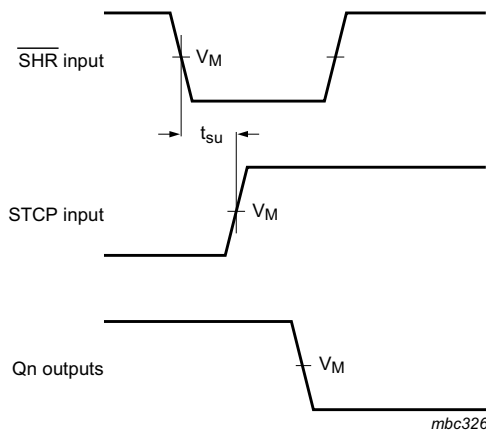

Measurement points are given in [Table 10](#).

**Fig 11. The set-up time shift reset (SHR) to storage clock (STCP)**

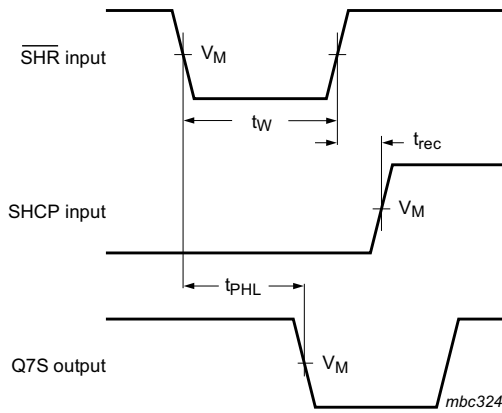

Measurement points are given in [Table 10](#).

$t_{PLH}$  and  $t_{PHL}$  are the same as  $t_{pd}$ .

**Fig 12.** The shift reset ( $\overline{\text{SHR}}$ ) pulse width, the shift reset to output (Q7S) propagation delay and the shift reset to shift clock (SHCP) recovery time

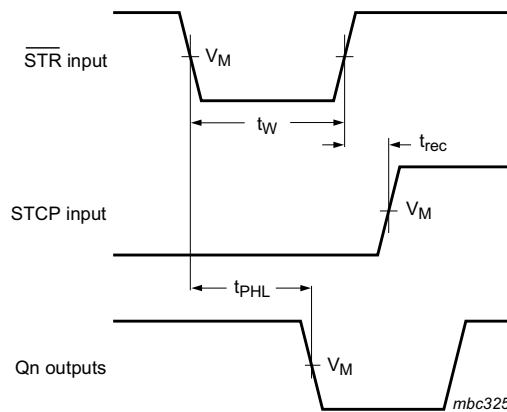

Measurement points are given in [Table 10](#).

$t_{PLH}$  and  $t_{PHL}$  are the same as  $t_{pd}$ .

**Fig 13.** The storage reset ( $\overline{\text{STR}}$ ) pulse width, the storage reset to output (Qn) propagation delay and the storage reset to storage clock (STCP) recovery time

**Table 10.** Measurement points

Type	Input	Output
	$V_M$	$V_M$
74HC594	$0.5 \times V_{CC}$	$0.5 \times V_{CC}$
74HCT594	1.3 V	1.3 V

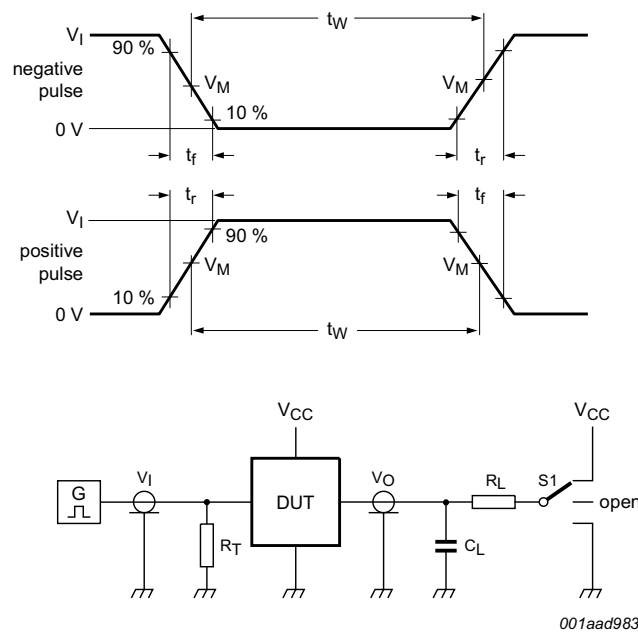

Test data is given in [Table 11](#).

Definitions test circuit:

$R_T$  = Termination resistance should be equal to output impedance  $Z_o$  of the pulse generator

$C_L$  = Load capacitance including jig and probe capacitance

$R_L$  = Load resistance

S1 = Test selection switch

**Fig 14. Test circuit for measuring switching times**

**Table 11. Test data**

Type	Input		Load		S1 position		
	$V_I$	$t_r, t_f$	$C_L$	$R_L$	$t_{PHL}, t_{PLH}$	$t_{PZH}, t_{PHZ}$	$t_{PZL}, t_{PLZ}$
74HC594	$V_{CC}$	6 ns	15 pF, 50 pF	1 k $\Omega$	open	GND	$V_{CC}$
74HCT594	3 V	6 ns	15 pF, 50 pF	1 k $\Omega$	open	GND	$V_{CC}$

13. Package outline

SO16: plastic small outline package; 16 leads; body width 3.9 mm

SOT109-1

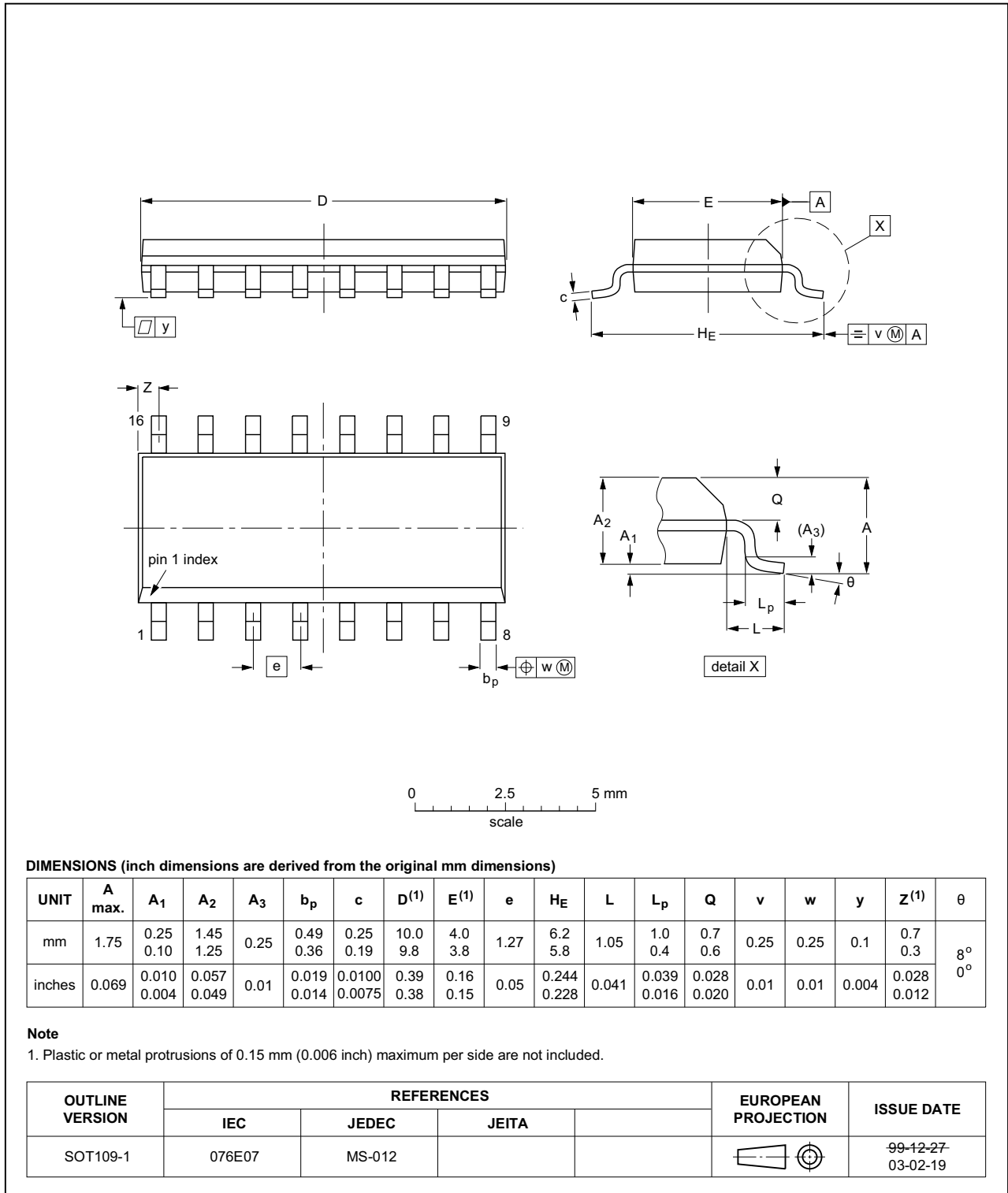

Fig 15. Package outline SOT109-1 (SO16)

SSOP16: plastic shrink small outline package; 16 leads; body width 5.3 mm

SOT338-1

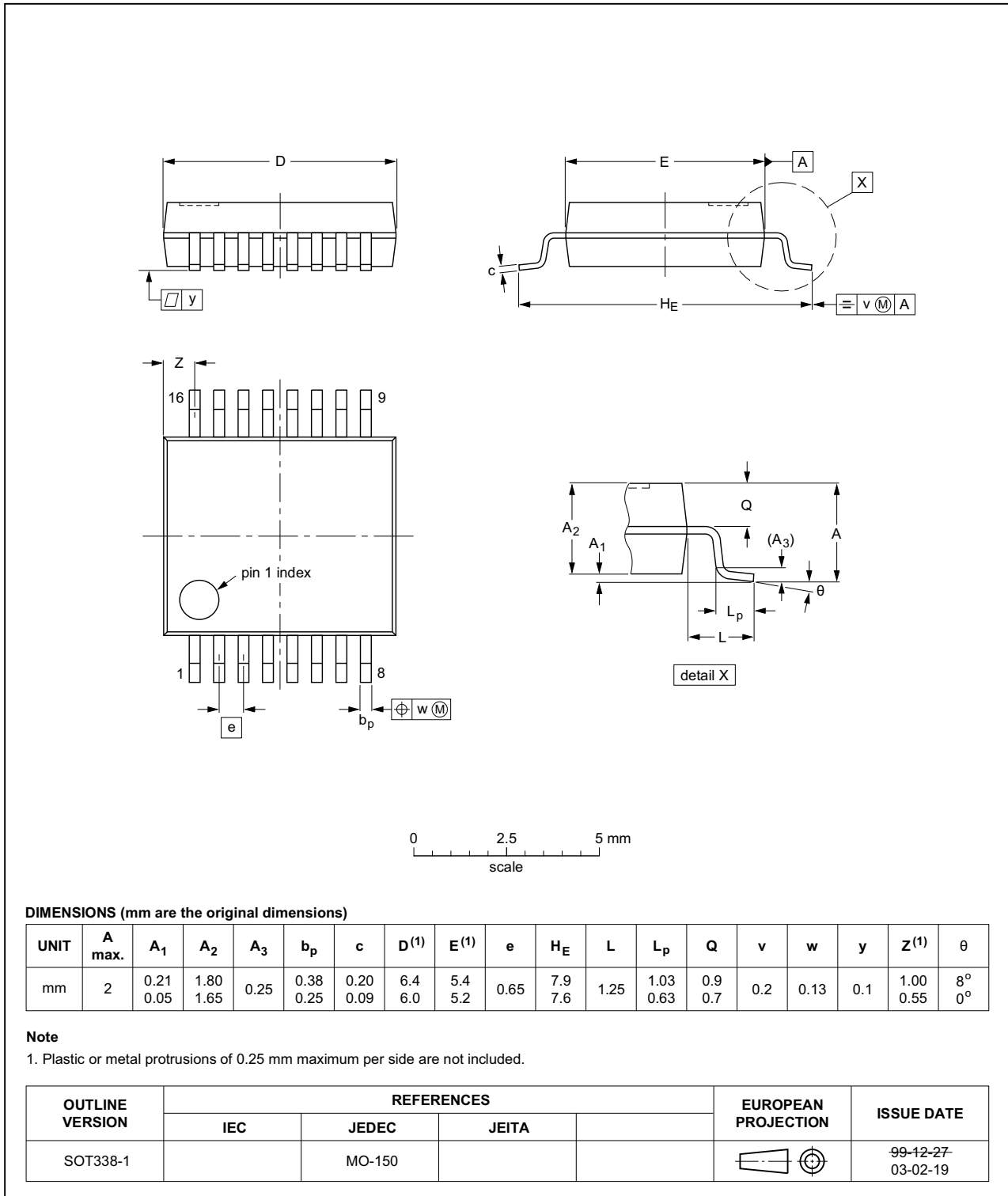

Fig 16. Package outline SOT338-1 (SSOP16)

## 14. Abbreviations

Table 12. Abbreviations

Acronym	Description
CMOS	Complementary Metal Oxide Semiconductor
DUT	Device Under Test
ESD	ElectroStatic Discharge
HBM	Human Body Model
LSTTL	Low-Power Schottky Transistor-Transistor Logic
MM	Machine Model
TTL	Transistor-Transistor Logic

## 15. Revision history

Table 13. Revision history

Document ID	Release date	Data sheet status	Change notice	Supersedes
74HC_HCT594 v.4	20160225	Product data sheet	-	74HC_HCT594 v.3
Modifications:	<ul style="list-style-type: none"> <li>Type numbers 74HC594N and 74HCT594N (SOT38-4) removed.</li> </ul>			
74HC_HCT594 v.3	20061220	Product data sheet	-	74HC_HCT594_CNV v.2
Modifications:	<ul style="list-style-type: none"> <li>The format of this data sheet has been redesigned to comply with the new identity guidelines of NXP Semiconductors.</li> <li>Legal texts have been adapted to the new company name where appropriate.</li> <li><a href="#">Table 1 "Ordering information"</a> updated.</li> </ul>			
74HC_HCT594_CNV v.2	19970908	Product specification	-	74HC_HCT594_CNV v.1

## 16. Legal information

### 16.1 Data sheet status

Document status <sup>[1][2]</sup>	Product status <sup>[3]</sup>	Definition
Objective [short] data sheet	Development	This document contains data from the objective specification for product development.
Preliminary [short] data sheet	Qualification	This document contains data from the preliminary specification.
Product [short] data sheet	Production	This document contains the product specification.

[1] Please consult the most recently issued document before initiating or completing a design.

[2] The term 'short data sheet' is explained in section "Definitions".

[3] The product status of device(s) described in this document may have changed since this document was published and may differ in case of multiple devices. The latest product status information is available on the Internet at URL <http://www.nexperia.com>.

### 16.2 Definitions

**Draft** — The document is a draft version only. The content is still under internal review and subject to formal approval, which may result in modifications or additions. Nexperia does not give any representations or warranties as to the accuracy or completeness of information included herein and shall have no liability for the consequences of use of such information.

**Short data sheet** — A short data sheet is an extract from a full data sheet with the same product type number(s) and title. A short data sheet is intended for quick reference only and should not be relied upon to contain detailed and full information. For detailed and full information see the relevant full data sheet, which is available on request via the local Nexperia sales office. In case of any inconsistency or conflict with the short data sheet, the full data sheet shall prevail.

**Product specification** — The information and data provided in a Product data sheet shall define the specification of the product as agreed between Nexperia and its customer, unless Nexperia and customer have explicitly agreed otherwise in writing. In no event however, shall an agreement be valid in which the Nexperia product is deemed to offer functions and qualities beyond those described in the Product data sheet.

### 16.3 Disclaimers

**Limited warranty and liability** — Information in this document is believed to be accurate and reliable. However, Nexperia does not give any representations or warranties, expressed or implied, as to the accuracy or completeness of such information and shall have no liability for the consequences of use of such information. Nexperia takes no responsibility for the content in this document if provided by an information source outside of Nexperia.

In no event shall Nexperia be liable for any indirect, incidental, punitive, special or consequential damages (including - without limitation - lost profits, lost savings, business interruption, costs related to the removal or replacement of any products or rework charges) whether or not such damages are based on tort (including negligence), warranty, breach of contract or any other legal theory.

Notwithstanding any damages that customer might incur for any reason whatsoever, Nexperia's aggregate and cumulative liability towards customer for the products described herein shall be limited in accordance with the *Terms and conditions of commercial sale* of Nexperia.

**Right to make changes** — Nexperia reserves the right to make changes to information published in this document, including without limitation specifications and product descriptions, at any time and without notice. This document supersedes and replaces all information supplied prior to the publication hereof.

**Suitability for use** — Nexperia products are not designed, authorized or warranted to be suitable for use in life support, life-critical or safety-critical systems or equipment, nor in applications where failure or malfunction of a Nexperia product can reasonably be expected to result in personal injury, death or severe property or environmental damage. Nexperia and its suppliers accept no liability for inclusion and/or use of Nexperia products in such equipment or applications and therefore such inclusion and/or use is at the customer's own risk.

**Applications** — Applications that are described herein for any of these products are for illustrative purposes only. Nexperia makes no representation or warranty that such applications will be suitable for the specified use without further testing or modification.

Customers are responsible for the design and operation of their applications and products using Nexperia products, and Nexperia accepts no liability for any assistance with applications or customer product design. It is customer's sole responsibility to determine whether the Nexperia product is suitable and fit for the customer's applications and products planned, as well as for the planned application and use of customer's third party customer(s). Customers should provide appropriate design and operating safeguards to minimize the risks associated with their applications and products.

Nexperia does not accept any liability related to any default, damage, costs or problem which is based on any weakness or default in the customer's applications or products, or the application or use by customer's third party customer(s). Customer is responsible for doing all necessary testing for the customer's applications and products using Nexperia products in order to avoid a default of the applications and the products or of the application or use by customer's third party customer(s). Nexperia does not accept any liability in this respect.

**Limiting values** — Stress above one or more limiting values (as defined in the Absolute Maximum Ratings System of IEC 60134) will cause permanent damage to the device. Limiting values are stress ratings only and (proper) operation of the device at these or any other conditions above those given in the Recommended operating conditions section (if present) or the Characteristics sections of this document is not warranted. Constant or repeated exposure to limiting values will permanently and irreversibly affect the quality and reliability of the device.

**Terms and conditions of commercial sale** — Nexperia products are sold subject to the general terms and conditions of commercial sale, as published at <http://www.nexperia.com/profile/terms>, unless otherwise agreed in a valid written individual agreement. In case an individual agreement is concluded only the terms and conditions of the respective agreement shall apply. Nexperia hereby expressly objects to applying the customer's general terms and conditions with regard to the purchase of Nexperia products by customer.

**No offer to sell or license** — Nothing in this document may be interpreted or construed as an offer to sell products that is open for acceptance or the grant, conveyance or implication of any license under any copyrights, patents or other industrial or intellectual property rights.

**Export control** — This document as well as the item(s) described herein may be subject to export control regulations. Export might require a prior authorization from competent authorities.

**Non-automotive qualified products** — Unless this data sheet expressly states that this specific Nexperia product is automotive qualified, the product is not suitable for automotive use. It is neither qualified nor tested in accordance with automotive testing or application requirements. Nexperia accepts no liability for inclusion and/or use of non-automotive qualified products in automotive equipment or applications.

In the event that customer uses the product for design-in and use in automotive applications to automotive specifications and standards, customer (a) shall use the product without Nexperia's warranty of the product for such automotive applications, use and specifications, and (b) whenever customer uses the product for automotive applications beyond

Nexperia's specifications such use shall be solely at customer's own risk, and (c) customer fully indemnifies Nexperia for any liability, damages or failed product claims resulting from customer design and use of the product for automotive applications beyond Nexperia's standard warranty and Nexperia's product specifications.

**Translations** — A non-English (translated) version of a document is for reference only. The English version shall prevail in case of any discrepancy between the translated and English versions.

## 16.4 Trademarks

Notice: All referenced brands, product names, service names and trademarks are the property of their respective owners.

## 17. Contact information

For more information, please visit: <http://www.nexperia.com>

For sales office addresses, please send an email to: [salesaddresses@nexperia.com](mailto:salesaddresses@nexperia.com)



## 18. Contents

---

<b>1</b>	<b>General description</b> .....	<b>1</b>
<b>2</b>	<b>Features and benefits</b> .....	<b>1</b>
<b>3</b>	<b>Applications</b> .....	<b>1</b>
<b>4</b>	<b>Ordering information</b> .....	<b>2</b>
<b>5</b>	<b>Functional diagram</b> .....	<b>2</b>
<b>6</b>	<b>Pinning information</b> .....	<b>4</b>
6.1	Pinning .....	4
6.2	Pin description .....	4
<b>7</b>	<b>Functional description</b> .....	<b>5</b>
<b>8</b>	<b>Limiting values</b> .....	<b>5</b>
<b>9</b>	<b>Recommended operating conditions</b> .....	<b>6</b>
<b>10</b>	<b>Static characteristics</b> .....	<b>6</b>
<b>11</b>	<b>Dynamic characteristics</b> .....	<b>10</b>
<b>12</b>	<b>Waveforms</b> .....	<b>14</b>
<b>13</b>	<b>Package outline</b> .....	<b>18</b>
<b>14</b>	<b>Abbreviations</b> .....	<b>20</b>
<b>15</b>	<b>Revision history</b> .....	<b>20</b>
<b>16</b>	<b>Legal information</b> .....	<b>21</b>
16.1	Data sheet status .....	21
16.2	Definitions .....	21
16.3	Disclaimers .....	21
16.4	Trademarks .....	22
<b>17</b>	<b>Contact information</b> .....	<b>22</b>
<b>18</b>	<b>Contents</b> .....	<b>23</b>

## Looking for pricing, stock, or lifecycle information?

Click below to explore more details on WIN SOURCE:

-  [View 74HC594D,118 on WIN SOURCE](#)
-  [Nexperia USA Inc. Information](#)

## Optimize Your Supply Chain with WIN SOURCE Solutions

-  Global Sourcing Solution
-  Obsolete Management
-  Cost Control Management
-  Shortage Management
-  Alternative Solution
-  Excess Inventory Management