



**THE DATASHEET OF
TLV320DAC3202CZJR**



LOW POWER HIGH FIDELITY I²S INPUT HEADSET IC

 Check for Samples: [TLV320DAC3202](#)

FEATURES

- Ground Referenced Click-Pop Free Class-G Stereo Headset Driver
- Capable of Driving 1 VRMS at the Headset Driver Output, Per Channel, in Phase
- 100-dB(A) Channel SNR With 6.5-mW of Quiescent Power Dissipation
- Built In Short-Circuit Protection for Preventing Supply Rails Overload
- Supports 8-, 11.025-, 12-, 16-, 24-, 32-, 44.1- and 48-kHz Sample Rates
- I²C Interface for Digital Control
- Supports 16-, 20-, 24- and 32-Bit Data Width
- Supports Standard I²S, PCM, Left and Right Justified Formats
- Supports Data Mixing With Gain Options

- 32-Step Volume Control from 4 to -59 dB
- Clocking: Internal Clock Derived from I²S BCLK
- Package: WCSP, 0.5 mm Pitch, 2 mm x 2.5 mm
- Power Supply: Direct Battery and IO Supply

APPLICATIONS

- Smart Phones and Music Phones
- Portable Navigation
- Personal Media Players
- PDAs
- Portable Game Consoles
- HDD and Flash-Based Portable Audio Players

DESCRIPTION

The TLV320DAC3202 is a high fidelity and low power headphone amplifier with integrated DAC and power rails. The small solution size and highly efficient operation maximizes battery life and performance. The digital audio interface supports industry standard formats such as I²S and PCM. Many features of this device such as volume setting, data width and sampling rate are configurable for optimum flexibility and efficiency. The headset power control automatically adjusts the rail voltage based on the input signal to maximize efficiency and performance. The control interface uses an industry standard I²C controller for ease of operation and reduction in device pin count.

Table 1. ORDERING INFORMATION⁽¹⁾

T _A	PACKAGE ⁽²⁾	ORDERABLE PART NUMBER
-30°C to 85°C	YZJ	Tape and reel of 250
		Tape and reel of 3000

- (1) For the most current package and ordering information, see the Package Option Addendum at the end of this document, or see the TI web site at www.ti.com.
- (2) While this part number includes the YZJ package designator, it does not conform to the standard YZJ footprint. Only the drawings below should be used for system design and not the YZJ drawing available from the TI Packaging website.

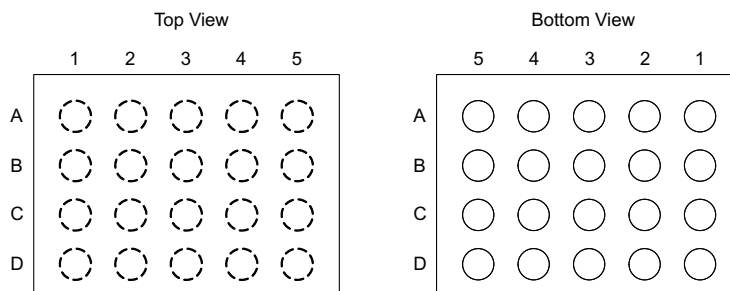

Please be aware that an important notice concerning availability, standard warranty, and use in critical applications of Texas Instruments semiconductor products and disclaimers thereto appears at the end of this data sheet.

FUNCTIONAL BLOCK DIAGRAM

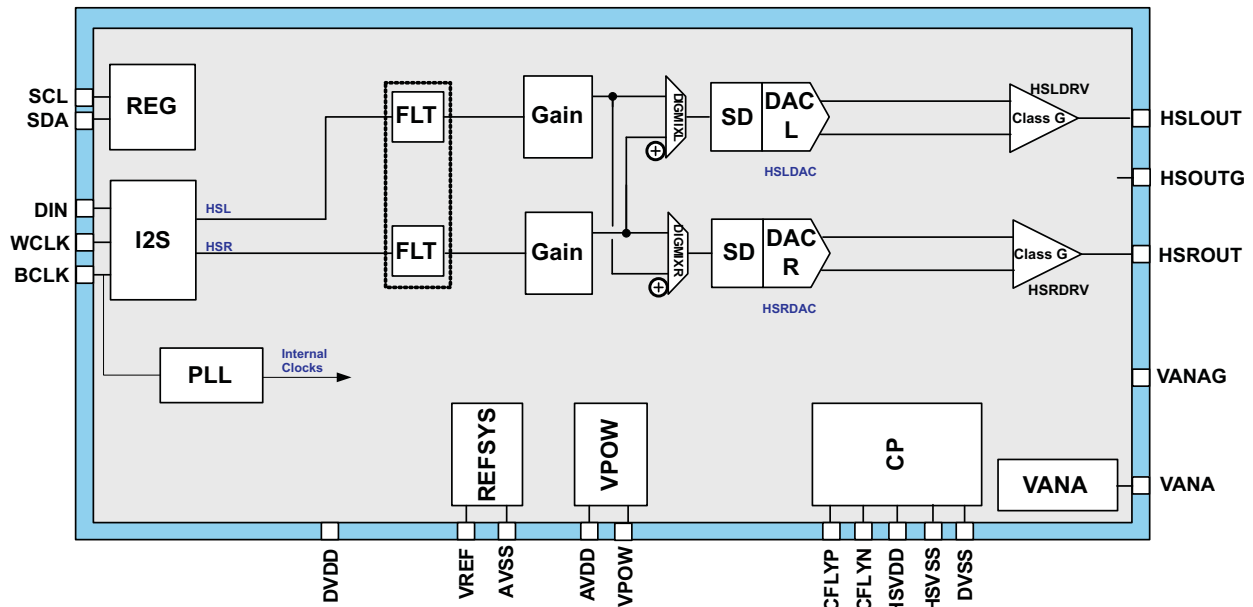

PIN ASSIGNMENTS

Table 2. PIN ASSIGNMENTS (TOP VIEW)

	1	2	3	4	5
A	AVSS	VANAG	VANA	CFLYP	CFLYN
B	VREF	AVDD	VPOW	DVDD	DVSS
C	SDA	SCL	HSOUTG	HSVDD	HSOUTL
D	BCLK	WCLK	DIN	HSOUTR	HSVSS

Table 3. TERMINAL FUNCTIONS

TERMINAL		I/O	VOLTAGE LEVEL (V)	DESCRIPTION
NAME	NO.			
AVSS	A1	Input	0	Analog ground
VANAG	A2	Input	0	Leave floating
VANA	A3	Output	1.55	Analog LDO output
CFLYP	A4	Input/Output	1.95	FLY cap "+" terminal
CFLYN	A5	Input/Output	-1.95	FLY cap "-" terminal
VREF	B1	Output	0.75	Analog reference output
AVDD	B2	Input	VBAT	2.3-V to 4.8-V battery input
VPOW	B3	Output	1.95	VPOW LDO output
DVDD	B4	Input	VIO	1.8-V IO digital supply
DVSS	B5	Input	0	Digital ground
SDA	C1	Input/Output	VIO	I ² C Data
SCL	C2	Input	VIO	I ² C CLK in
HSOUTG	C3	Input	0	Headset feedback ground
HSVDD	C4	Input/Output	1.95	Headset positive supply
HSOUTL	C5	Output	+/-1.5	Headset output left
BCLK	D1	Input	VIO	I ² S bit clock
WCLK	D2	Input	VIO	I ² S word clock
DIN	D3	Input	VIO	I ² S downlink data

Table 3. TERMINAL FUNCTIONS (continued)

TERMINAL		I/O	VOLTAGE LEVEL (V)	DESCRIPTION
NAME	NO.			
HSOUTR	D4	Output	±1.5	Headset output right
HSVSS	D5	Input/Output	-1.95	Headset negative supply

ABSOLUTE MAXIMUM RATINGS⁽¹⁾

All voltages values are with respect to GND. Over operating free-air temperature range (unless otherwise noted).

		VALUE	UNIT
AVDD (V _{BAT})	DC	-0.3 to 5	V
	AC ⁽²⁾	-0.3 to 5.5	
DVDD (V _{IO})	DC	-0.3 to 2.1	V
	AC ⁽²⁾	-0.3 to 2.2	
T _A	Operating free air temperature	-40 to 85	°C
T _J	Maximum junction temperature	125	°C
T _{stg}	Storage temperature	-65 to 150	°C
	Lead temperature	115	°C
ESD rating (all pins)	Human Body Model	-2000 to 2000	V
	Charged Device Model	-500 to 500	

- Stresses beyond those listed under “absolute maximum ratings” may cause permanent damage to the device. These are stress ratings only and functional operation of the device at these or any other conditions beyond those indicated under “recommended operating conditions” is not implied. Exposure to absolute-maximum-rated conditions for extended periods may affect device reliability.
- For spike duration of 1 ms, 10,000 times over 7 years (lifetime).

RECOMMENDED OPERATING CONDITIONS

over operating free-air temperature range (unless otherwise noted)

		MIN	NOM	MAX	UNIT
T _A	Operating free air temperature	-30		85	°C
T _{stg}	Storage temperature	-55		150	°C

ELECTRICAL CHARACTERISTICS

AVDD = 3.7 V, DVDD = 1.8 V, T_A = 25°C, unless otherwise specified.

PARAMETER	TEST CONDITIONS	MIN	TYP	MAX	UNIT
AVDD (V _{BAT})	Functional only	2.3		4.8	V
	Parametric performance	2.3		4.8	
DVDD (V _{IO})		1.65	1.8	1.95	V
V _{IH} , digital ⁽¹⁾		0.65 x V _{IO}			V
V _{IL} , digital ⁽¹⁾				0.35 x V _{IO}	V
HSOUTL/R Voltage	Enabled	-1.5		1.5	V
	Disabled, HiZ			1.8	
Power consumption from all supplies with internal PLL (SNR = 100 dBA)	No load		6.5		mW
	0.1 mW/channel, 1 kHz, 32 Ω		9.7		

(1) CHIP_EN = 1, HSLLEN = 1, HSREN = 1, active I²S, idle channel, amplifiers muted

ELECTRICAL CHARACTERISTICS (continued)AVDD = 3.7 V, DVDD = 1.8 V, T_A = 25°C, unless otherwise specified.

PARAMETER		TEST CONDITIONS	MIN	TYP	MAX	UNIT
Shutdown current		AVDD, GND mode ⁽²⁾			2	μA
		DVDD, GND mode ⁽²⁾			2	
		AVDD, HiZ mode ⁽³⁾			1	
		DVDD, HiZ mode ⁽³⁾			1	
Startup time		From CHIP_EN assertion to Florin reaching Standby state (clock and power supplies available)		15.5		ms
Wake up time		From HSL/R_EN assertion to Florin reaching Active state, during which the system is completely powered up with headset drivers enabled		3		ms
AUDIO PATH ELECTRICAL PERFORMANCE						
	Maximum amplitude at ball	0-dB PCM, 1 kHz, THD = 1%, 32-Ω load, 4-dB gain		1.05		V _{rms}
	Amplitude across load	32-Ω load		0.7		V _{rms}
		16-Ω load		0.45	0.5	
	Dynamic range	1 kHz, -60 dBFS, A-weighted		97	100	dB (A)
THD+N		1 kHz, 16-Ω load in series with 10 Ω (R _{EMI})	P _{OUT} = 20 mW	68		dB
			P _{OUT} = 12 mW	70 74		
			P _{OUT} = 4 mW	72		
	Frequency response	20 Hz to 20 kHz		-0.25	0.25	dB
	Channel separation	1 kHz, full scale input ⁽⁴⁾		90	95	dB
PSRR		217 Hz, 500-mVpp ripple on AVDD		80	90	dB
	Pop noise specification ⁽⁵⁾	Maximum DC value after power up			0.5	mV
RECEIVE CHANNEL DIGITAL FILTER PERFORMANCE, F_s = 44.1 kHz or 48 kHz						
	HPF -3 dB corner			0.8		Hz
	LPF pass band corner frequency	-10 dBFS		5	0.42 F _s	Hz
	LPF pass band ripple			-0.25	0.25	dB
	LPF -3 dB corner			0.48 F _s		Hz
	LPF interpolation multiplier			8		
	LPF magnitude response	< 0.16 F _s		-0.05	0.05	dB
	LPF stop band corner frequency			0.6 F _s		Hz
	LPF stop band attenuation	< 2 F _s		70		dB
	Absolute delay	Filter only, at 1 kHz, without HPF Excludes interface + compute latency		11/ F _s		s
AUDIO INTERFACE TIMING PARAMETERS						
T _{bclk}	Audio clock period	Variable BCLK		1/BCLK		ns
T _{bclkh}	BCLK high duration			0.35 x BCLK period		ns
T _{bckl}	BCLK low duration			0.35 x BCLK period		ns
T _{dv}	Data hold time following BCLK falling edge			20		ns

(2) CHIP_EN = 0, HIZ_L = 0, HIZ_R = 0

(3) CHIP_EN = 0, HIZ_L = 1, HIZ_R = 1

(4) The maximum board resistance should be less than 250 mΩ between the HSOUTL/HSOUTR pins and the HSOUTG pin.

(5) Maximum slew rate (ΔV/Δt) < 5 V/s after A-weighting

ELECTRICAL CHARACTERISTICS (continued)

 AVDD = 3.7 V, DVDD = 1.8 V, T_A = 25°C, unless otherwise specified.

	PARAMETER	TEST CONDITIONS	MIN	TYP	MAX	UNIT
T _{FS}	Sample clock setup time following BCLK falling edge				10	ns
T _{ds}	Data set time before BCLK rising edge		0.2 x BCLK period			ns
T _{dh}	Data hold time after BCLK rising edge		0.2 x BCLK period			ns
T _{wclks}	Short frame sync pulse width			1/BCLK		ns

TYPICAL PERFORMANCE CHARACTERISTICS

**DAC TO HEADSET FFT
AT -3 dBFS WITH 32-Ω HEADSET**

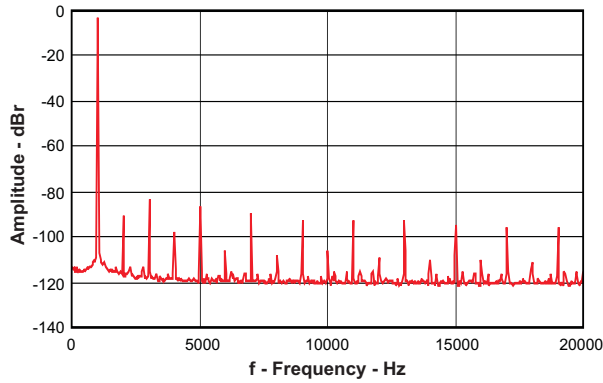

Figure 1.

**DAC TO HEADSET FFT
AT -3 dBFS WITH 16-Ω HEADSET**

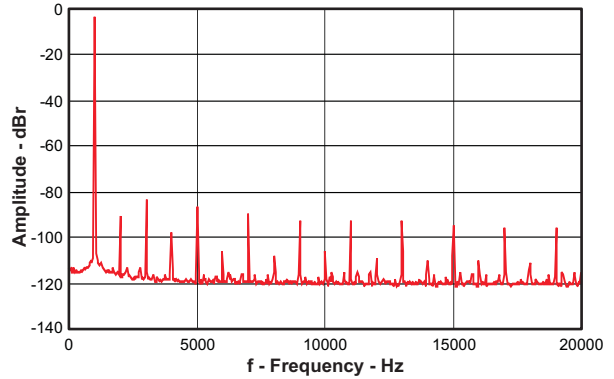

Figure 2.

**CLICK AND POP PERFORMANCE
WITH 32-Ω HEADSET**

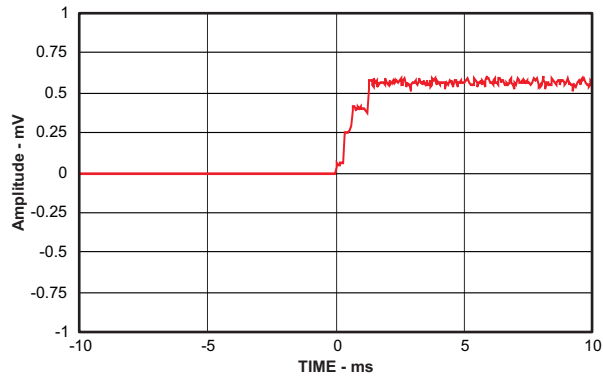

Figure 3.

**CLICK AND POP PERFORMANCE
WITH 16-Ω HEADSET**

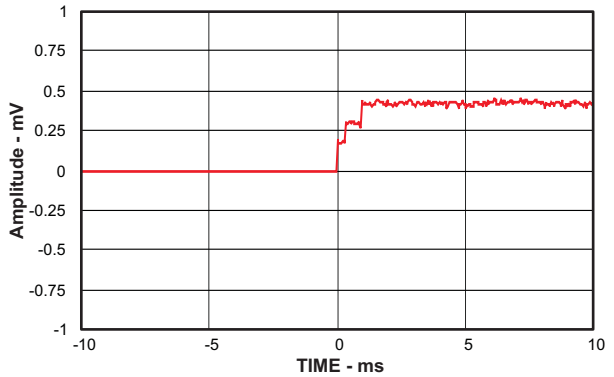

Figure 4.

**TOTAL HARMONIC DISTORTION + NOISE
vs
HEADPHONE OUTPUT POWER
WITH 32-Ω HEADSET**

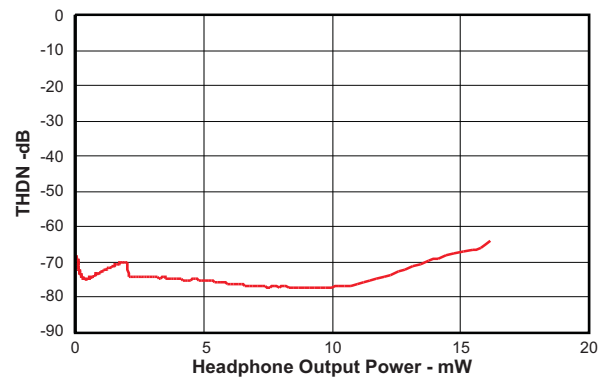

Figure 5.

**TOTAL HARMONIC DISTORTION + NOISE
vs
HEADPHONE OUTPUT POWER
WITH 16-Ω HEADSET**

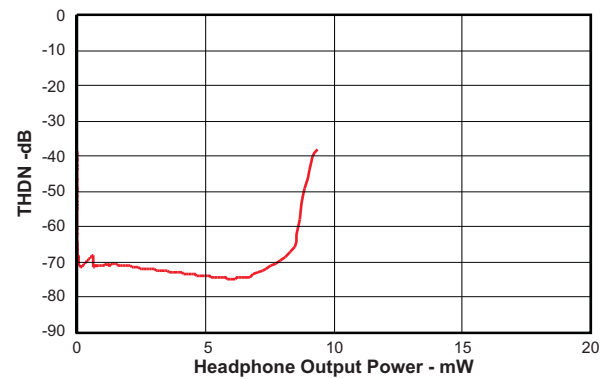

Figure 6.

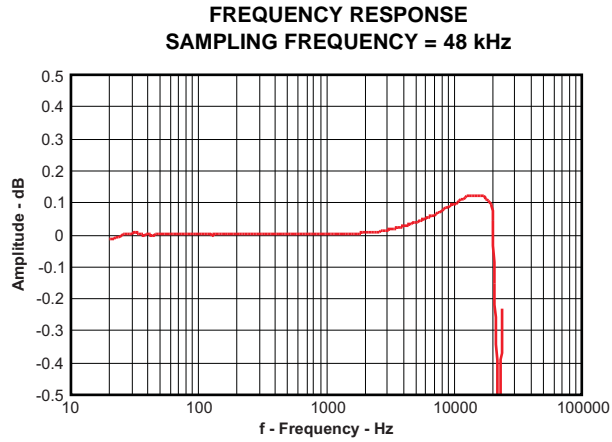

Figure 7.

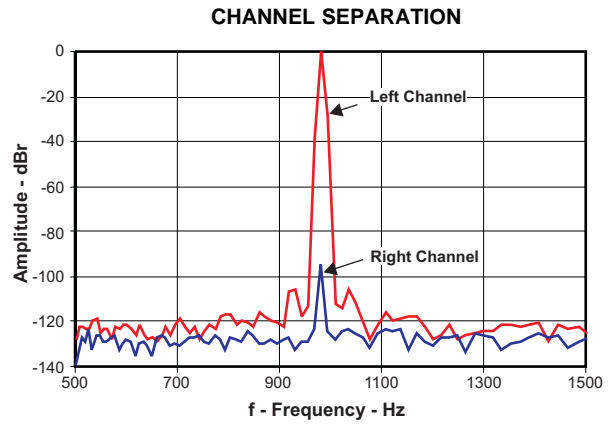

Figure 8.

DIGITAL INTERFACE

Audio Interface

The audio interface for data communication with application processor or modem supports multiple formats such as I²S, left justified, right justified or the short frame sync PCM formats. The default interface format is I²S at 48-kHz sampling rate and 16-bit data size. The clock input selection module within PLL block also supports multiple input frequency options. The input clock must be in standard square wave format; hence a clock squarer is not necessary. The following tables shows the details of audio interface configuration through I²C register controls.

Table 4. Audio Interface Format Configuration Register

INTF_MODE (1:0)		INTERFACE FORMAT TYPE
0	0	Standard I ² S
0	1	Left justified I ² S
1	0	Right justified I ² S
1	1	Short PCM

Table 5. Audio Interface BCLK to WCLK Ratio Setting Register

INTF_FRAME_SIZE (2:0)			INTF_SIZE (1:0)		INTERFACE FRAME SIZE, BCLK/WCLK
0	0	0	0	0	2 x 16 x F _s
0	0	1	0	1	2 x 20 x F _s
0	1	0	1	0	2 x 24 x F _s
0	1	1	1	1	2 x 32 x F _s
1	0	0	0	0	4 x 16 x F _s
1	0	1	0	1	4 x 20 x F _s
1	1	0	1	0	4 x 24 x F _s
1	1	1	1	1	4 x 32 x F _s

Table 6. Audio Sampling Rate Setting Register

CLK_MODE(3:0)				INTERFACE SAMPLING RATE, WCLK (kHz)
0	0	0	0	8
0	0	0	1	11.025
0	0	1	0	12
0	0	1	1	NA
0	1	0	0	16
0	1	0	1	22.05
0	1	1	0	24
0	1	1	1	NA
1	0	0	0	32
1	0	0	1	44.1
1	0	1	0	48
1	0	1	1	NA
1	1	0	0	NA

Table 7. Detailed Configuration of Interface Including PLL Setup Registers

BCLK/WCLK	DATA SIZE	F _s (WCLK)	F _s x DATA	BCLK/PLL INPUT
32	16	48.000	1536	1536
40	20	48.000	1920	1920
48	24	48.000	2304	2304
64	32	48.000	3072	3072

Table 7. Detailed Configuration of Interface Including PLL Setup Registers (continued)

BCLK/WCLK	DATA SIZE	F _s (WCLK)	F _s x DATA	BCLK/PLL INPUT
32	16	44.100	1411.2	1411.2
40	20	44.100	1764	1764
48	24	44.100	2116.8	2116.8
64	32	44.100	2822.4	2822.4
64	16	8.000	256	512
64	16	11.025	352.8	705.6
64	16	12.000	384	768
64	16	16.000	512	1024
64	16	22.050	705.6	1411.2
64	16	24.000	768	1536
64	16	32.000	1024	2048
64	16	44.100	1411.2	2822.4
64	16	48.000	1536	3072
80	20	8.000	320	640
80	20	11.025	441	882
80	20	12.000	480	960
80	20	16.000	640	1280
80	20	22.050	882	1764
80	20	24.000	960	1920
80	20	32.000	1280	2560
80	20	44.100	1764	3528
80	20	48.000	1920	3840
96	24	8.000	384	768
96	24	11.025	529.2	1058.4
96	24	12.000	576	1152
96	24	16.000	768	1536
96	24	22.050	1058.4	2116.8
96	24	24.000	1152	2304
96	24	32.000	1536	3072
96	24	44.100	2116.8	4233.6
96	24	48.000	2304	4608
128	32	8.000	512	1024
128	32	11.025	705.6	1411.2
128	32	12.000	768	1536
128	32	16.000	1024	2048
128	32	22.050	1411.2	2822.4
128	32	24.000	1536	3072
128	32	32.000	2048	4096
128	32	44.100	2822.4	5644.8
128	32	48.000	3072	6144

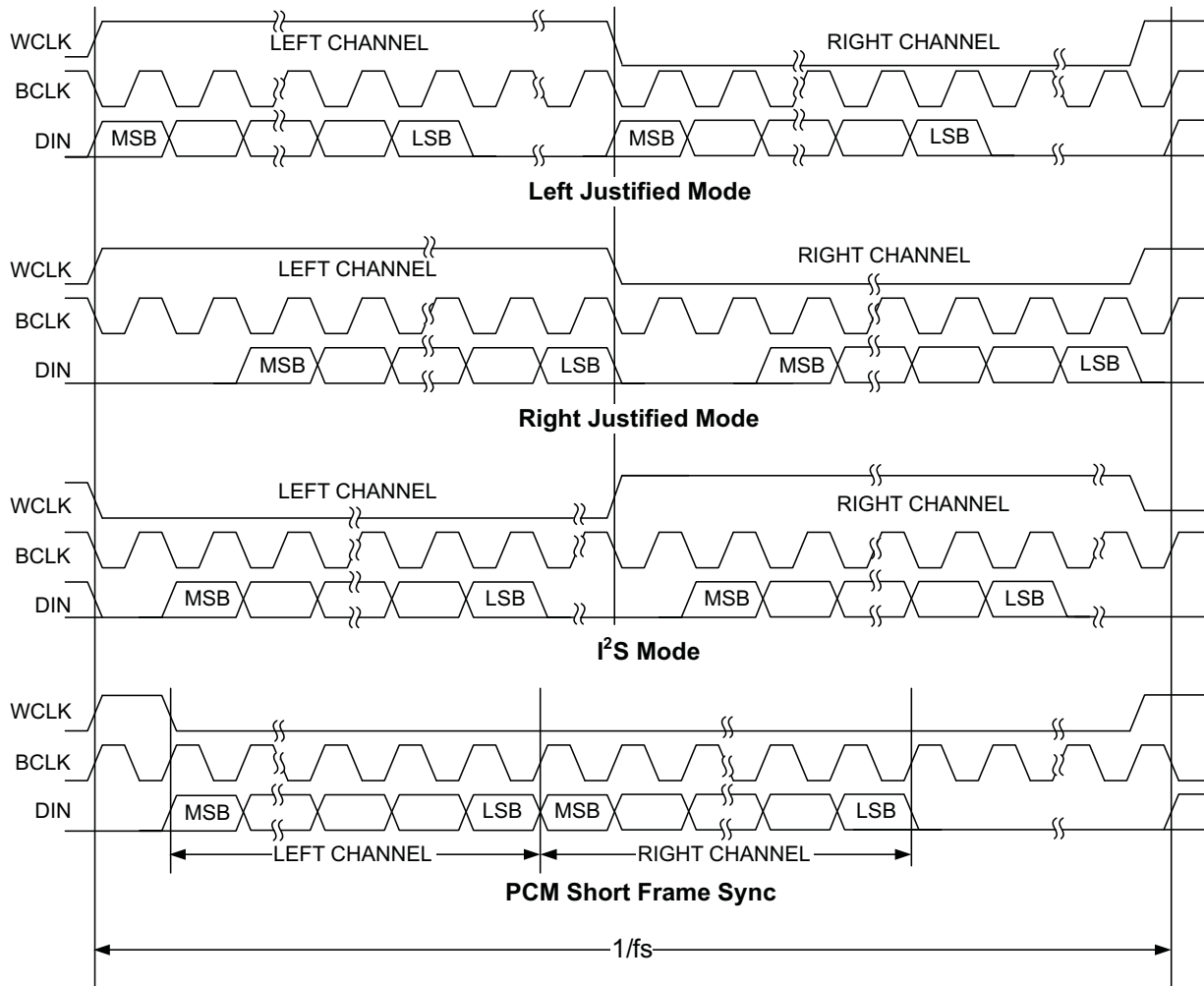

Figure 9. Interface Format Supporting Four Different Options

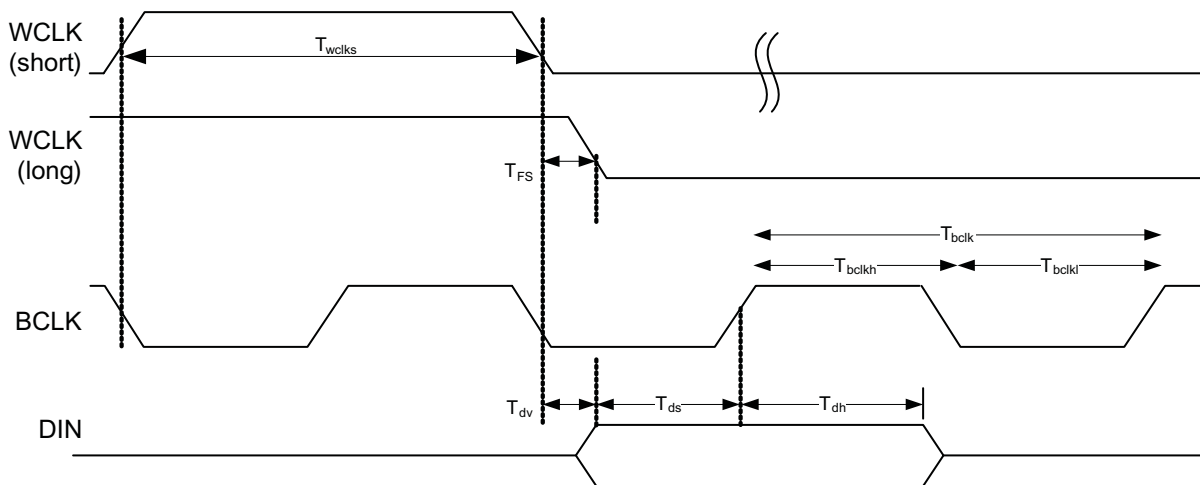

Figure 10. Interface Timing for I²S (Long) or PCM (Short) WCLK Options

AUDIO

Channel Performance

The receive channel of TLV320DAC3202 converts the digital signal to analog for the headset amplifier through a highly efficient low-power DAC. The signal in stereo I²S format with configurable data size drives the Class G amplifier after the conversion. The channel gain is implemented in two segments in digital and analog domains. In digital domain the gain steps have finer resolution whereas in the analog domain the amplifier gain steps are defined at 2-dB resolution. The detail of volume control is shown in the register map description. The mixing feature allows the left and right channels to be combined in digital domain prior to conversion and then routed to either channel. The audio signal can be disabled either by soft mute feature in the digital domain or by disabling the output amplifier.

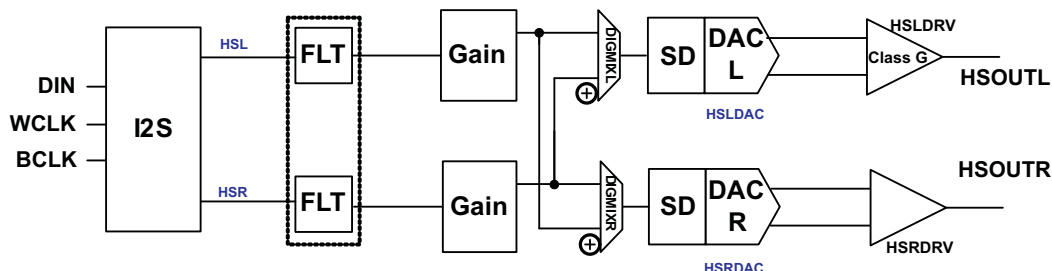

Figure 11. Audio Path Diagram

Volume Control

The volume control module is implemented with combination of digital and analog gain settings for optimum performance. The total gain range is from 4 dB to -59 dB with variable steps. The gain for the amplifiers is from 4 dB to -12 dB in 2-dB steps.

Table 8. Volume Control Register Decoding

REGISTER VALUE	GAIN (dB)	GAIN_ANALOG (dB)	GAIN_DIGITAL (dB)
31	4	4	0
30	3	4	-1
29	2	2	0
28	1	2	-1
27	0	0	0
26	-1	0	-1
25	-2	-2	0
24	-3	-2	-1
23	-4	-4	0
22	-5	-4	-1
21	-6	-6	0
20	-7	-6	-1
19	-8	-8	0
18	-9	-8	-1
17	-10	-10	0
16	-11	-10	-1
15	-13	-12	-1
14	-15	-12	-3
13	-17	-12	-5
12	-19	-12	-7
11	-21	-12	-9

Table 8. Volume Control Register Decoding (continued)

REGISTER VALUE	GAIN (dB)	GAIN_ANALOG (dB)	GAIN_DIGITAL (dB)
10	-23	-12	-11
9	-25	-12	-13
8	-27	-12	-15
7	-31	-12	-19
6	-35	-12	-23
5	-39	-12	-27
4	-43	-12	-31
3	-47	-12	-35
2	-51	-12	-39
1	-55	-12	-43
0	-59	-12	-47

SYSTEM AND CONTROL

Power-Up Sequence

The power up sequence of the IC is initiated by asserting the CHIP_EN bit to logic '1'. It is expected that V_{BAT} and V_{IO} are powered up prior to assertion of this bit. The HSL/R amplifiers are then enabled by writing to their perspective control bits in register address 0x01. The I²S clock must be present prior to power up sequence and maintain its activity during active mode. The figure below shows the typical power up sequence of the IC. The IC power up state machine updates I²C register bits corresponding to enabled modules. I²C register control can subsequently be used to turn OFF unused circuits.

The power down sequence is initiated by de-asserting the CHIP_EN bit in CODEC_EN register. It is expected that the CHIP_EN bit is de-asserted prior to turning OFF the V_{IO} supply.

The HS driver power on/off sequence is designed to be click-pop free.

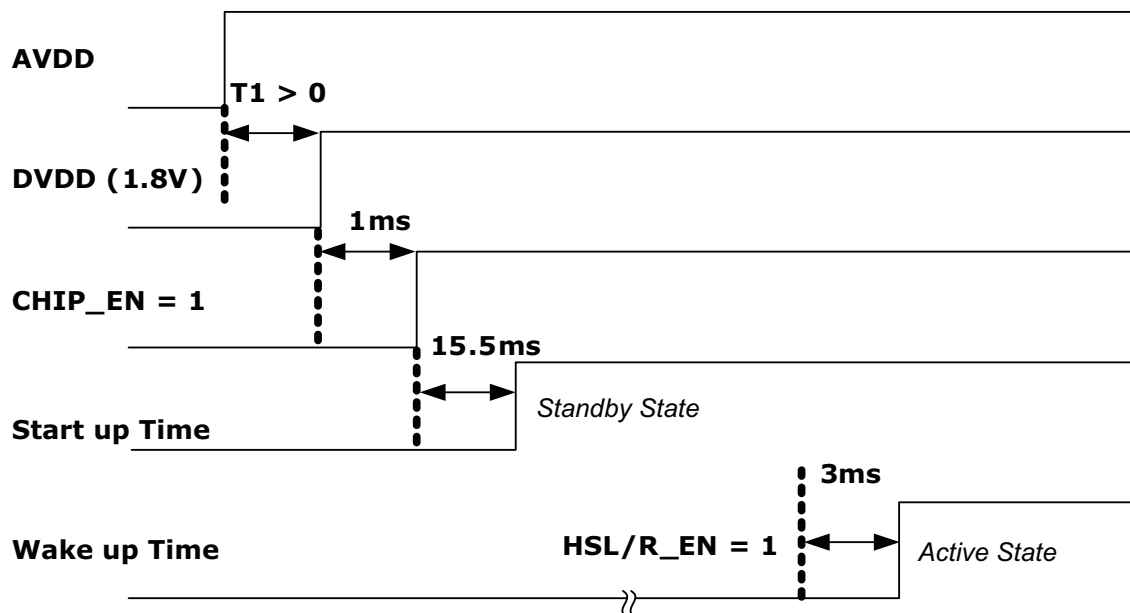

Figure 12. Power-Up Sequence Timing

Dual Supply Charge Pump

The charge pump on TLV320DAC3202 has dual-supply capability module with automatic selection which can be either from V_{BAT} or V_{IO} depending on the input signal range and load current that is detected. Charge pump generates both the positive and negative rails for low and high headset rails. For typical listening range where the signal level is low, the supply is expected to be from V_{IO} and headset rail is 0.9 V. For higher signal levels where higher current drains from V_{IO} are not possible, the IC uses an automatic input voltage and load current threshold based algorithm to switch ON the V_{POW} regulator and use V_{POW} , which is powered from V_{BAT} . It is designed to power the left and right headset drivers up to rated full scale output.

The threshold point to transition between the low and high power range can be programmed through I²C interface. There are two threshold points controlled by register bits, one for each of left and right channels. The threshold monitor mechanisms for each channel can be independently enabled and programmed. The load current threshold settings can be 10.5 mA, 11.5 mA, 12.5 mA (default) or 13.5 mA per channel.

Output Impedance

In order to share the output connector between audio and other signals such as video output, a high impedance option is implemented that can be enabled through I²C controller. In this mode the output impedance is increased while the signal is muted. As shown in below table the output impedance is large enough to avoid an unwanted attenuation of other signal connected to the jack contact.

Table 9. Output Impedance in Various Mode Settings

CHIP_EN	HiZ	HS_EN	IMPEDANCE	MODE
0	0	0	150 Ω	Shut down
0	0	1	150 Ω	Shut down
0	1	0	8.5 Ω at 40 kHz	HiZ
			600 Ω at 6 MHz	
			400 Ω at 13 MHz	
0	1	1	-	Invalid
1	0	0	150 Ω	Active, HS off
1	0	1	-	Active
1	1	0	-	Invalid
1	1	1	-	Invalid

I²C INTERFACE

The control interface for programming the registers on TLV320DAC3202 is done using a standard I²C interface with the IC operating in slave mode. The 2 modes of operation as defined in Ref [1,2] are (a) Standard-mode up to 100 kbit/s, and (b) Fast-mode up to 400 kbit/s. The IC defaults to fast-mode. A 7-bit slave addressing is used. The device I²C slave address is fixed to 0011010X, with 00110100 for master write cycle (TLV320DAC3202 reads) and 00110101 for master read cycle (TLV320DAC3202 writes). For data and clock lines, pull up resistors are required and are expected to be provided as defined in section 7 of Ref [1].

References

[1] UM10204: I²C-Bus Specification and user manual Rev. 03 – 19 June 2007

[2] The I²C-BUS SPECIFICATION VER 2.1 January 2000

[3] I²S Bus specification, Phillips Semiconductors, June 1996

Register Map

Table 10. Register Map Designation for I²C Interface

ADDRESS	REGISTER	D7	D6	D5	D4	D3	D2	D1	D0	INITIAL VALUE	ACCESS (R, W, WR)	
0x00												
0x01	EN	HSL_EN	HSR_EN	-	-	-	-	THERMAL	CHIP_EN	0x00	R	
0x02	VOL_CTRL	HSL_MUTE	HSR_MUTE	VOLCTRL(4:0)					-	0xC0	WR	
0x03	HIZ_CTRL	-	-	SPARE	SPARE	-	-	HIZ_L	HIZ_R	0x00	WR	
0x04	ASICREV	ASICID(3:0)				VERSION(3:0)				0x00	R	
0x05	I2CID	I2CID(7:0)								0x34	R	
0x06	HS_LP2HP_SW1	HS_LP_MODE	HS_BYPASS_CUR_SW	-	-	HSL_CUR_THRD(1:0)		HSR_CUR_THRD(1:0)		0x00	WR	
0x07	CODEC_EN	HSL_DRV_EN	HSR_DRV_EN	CP_EN	PLL_EN	REF_EN	-	DACL_EN	DACR_EN	0x00	W	
0x08	CODEC_CTRL	HSL_FIR_EN	HSR_FIR_EN	HSL_RAMP_DIS	HSR_RAMP_DIS	HSL_MIX_CTRL(1:0)		HSR_MIX_CTRL(1:0)		0x00	WR	
0x09	INTF	INTF_MODE(1:0)		INTF_DATA_SIZE(1:0)		-	INTF_FRAME_SIZE(2:0)			0x00	WR	
0x0A	FIR	CLK_MODE(3:0)				-	-	INTERPOLATION(1:0)		0xA3	WR	
0x0B	CP	CP_OPEN	CP_HPMODE	CP_ENCLAMP	CP_FET_SIZE(2:0)			-	-	0x00	WR	
0x0C	REF	-	-	REF_CM_HIGH_SWING(1:0)		REF_CUR(3:0)				0x00	WR	
0x0D	DAC	DAC_INV_CLK	OFFSET_CORR_EN	-	-	DACR_SWING	DACL_SWING	DACR_LP	DACL_LP	0x00	WR	
0x0E	HS_LP2HP_SW2	HP_LOW_IBIAS	HS_BYPASS_SHTDN	HS_SW_OVER_SPEED(1:0)		HS_AMP_SW_OVER(1:0)		HS_HIGHAMP_SW_OVER(1:0)		0x80	WR	
0x11	PM_EN	REFSYS_EN	-	SPARE_W	VANA_EN	-	VPOW_EN	-	-	0x00	W	
0x12	PM_LDO	-	-	VPOW_OUT(1:0)		-	-	VANA_OUT(1:0)		0x00	WR	
0x18	UNLOCK_PM	-	-	-	-	-	-	-	UNLOCK_PM	0x00	WR	
0x19	PM_TEST1	TEST_REFSYS_SET_BG	EEPROM_BYPASS	SPARE	TEST_VANA_HIZ	-	TEST_VPOW_HIZ	EEPROM_PROGRAM	DIEID_PROGRAM	0x00	WR	
0x1A	HS_TEST	SPARE	SPARE	TEST_HSL_TM1	TEST_HSL_OCDIS	TEST_DC2DAC	TEST_ISUM_DETECT	TEST_HSR_TM1	TEST_HSR_OCDIS	0x00	WR	
0x1B	CODEC_TEST1	CODEC_TEST_MUX(3:0)				TEST_BYP_FIR	TEST_CP_CLK(2:0)				0x00	WR
0x1C	CODEC_TEST2	TEST_BYP_MOD	TEST_BYP_RANDOMIZER	TEST_PLL_OVERRIDE_EN	PLL_PRE_DIV_OVR(4:0)						0x00	WR
0x1D	CODEC_TEST3	SPARE	PLL_FB_LOOP_OVR(6:0)								0x00	WR
0x1E	CODEC_TEST4	CP_TEST(1:0)		PLL_TEST_MODE_L(5:0)						0x30	WR	
0x1F	CODEC_TEST5	PLL_TEST_MODE_H(7:0)									0x00	WR

PCB DEVELOPMENT

The following table explains the PCB recommendations. In addition, it is recommended to split the ground plane into analog and digital segment for clean and noisy signals. They should be connected only in a single point to avoid ground loop.

Table 11. PCB Recommendations

BALL NAME	DESCRIPTION	LAYOUT RECOMMENDATIONS
AVSS	Analog ground	
VANAG	Connected to VANA via capacitor	Connect to output capacitor with < 10 mΩ.
VANA	Analog LDO output	Connect to output capacitor with < 10 mΩ.
DVDD	IO/Digital supply	Minimize the resistance path with adequate decoupling very close to the ball.
CFLYP	FLY capacitor "+" terminal	Connect to positive side of output capacitor with < 10 mΩ.
VREF	Analog reference output	Connect to AVSS via output capacitor. The capacitor trace on the AVSS side of the capacitor should not be connected to GND plane directly but at the AVSS pin. See application diagram.
AVDD	2.3-V to 4.8-V battery input	Minimize the resistance path with adequate decoupling very close to the ball.
VPOW	CP LDO output	Minimize the resistance path with adequate decoupling very close to the ball.
DVSS	Digital ground	Connect to separate GND plane for noisy signals, i.e. PLL and interfaces. Connect the two planes in a single point to avoid GND loop.
CFLYN	FLY capacitor "-" terminal	Connect to negative side of output capacitor with < 10 mΩ.
SDA	I ² C data	Keep this away from clean quite signal paths over the digital GND plane.
SCL	I ² C CLK in	Keep this away from clean quite signal paths over the digital GND plane.
HSOUTG	HS feedback ground	Trace impedance must be very small, < 60 mΩ. This is important for cross talk reduction. Connection to GND plane must be at IC ball.
HSVDD	HS positive supply	Decouple this path to DVSS with trace impedance of < 20 mΩ.
HSOUTL	HS output left	Must be routed in differential pair with GNDHS to the connector. Match the impedances and as small as possible.
DIN	I ² S downlink data	Keep this trace away from quite GND/signal traces.
WCLK	I ² S word clock	Keep this trace away from quite GND/signal traces.
BCLK	I ² S bit clock	Keep this trace away from quite GND/signal traces.
HROUTR	HS output right	Must be routed in differential pair with GNDHS to the connector. Match the impedances and as small as possible.
HSVSS	HS negative supply	Decouple this path to DVSS with trace impedance of < 20 mΩ.

TYPICAL CIRCUIT CONFIGURATION

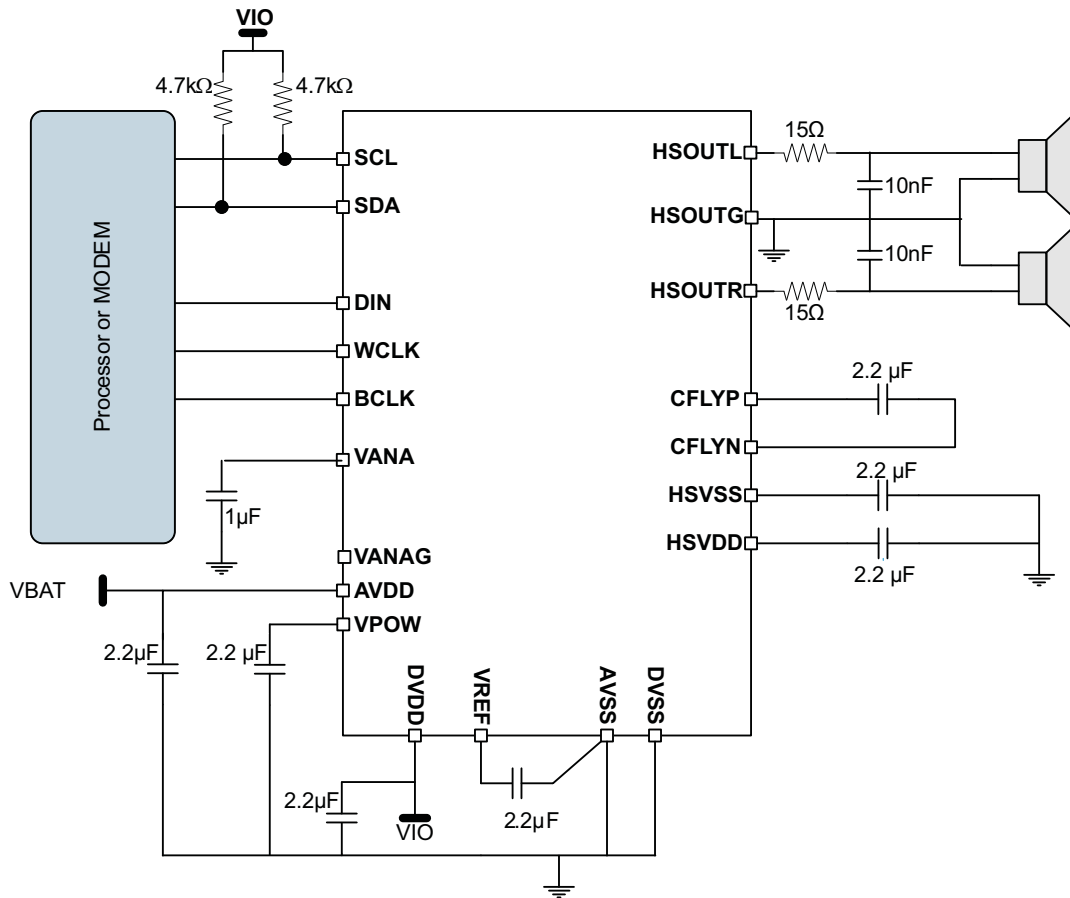

Figure 13. Typical Circuit

Table 12. External Component List⁽¹⁾

PIN NAME	DESCRIPTION
AVDD	2.2 μF, 6.3-V tolerance
VPOW	2.2 μF, 6.3-V tolerance
VREF	2.2 μF, 6.3-V tolerance
VANA	1 μF, 6.3-V tolerance
HSVDD	2.2 μF, 6.3-V tolerance
HSVSS	2.2 μF, 6.3-V tolerance
CFLYP/N	2.2 μF, 6.3-V tolerance
DVDD	2.2 μF, 6.3-V tolerance

(1) The headset amplifiers output power and distortion are characterized using the nominal capacitance for the supply, ground, output loads, and the charge pump fly cap as shown in the above application diagram. To meet the stated performance with discrete component variations, it is recommended that the external components be chosen to account for manufacturing tolerance, voltage and temperature de-rating.

TAPE AND REEL INFORMATION



QUADRANT ASSIGNMENTS FOR PIN 1 ORIENTATION IN TAPE



*All dimensions are nominal

Device	Package Type	Package Drawing	Pins	SPQ	Reel Diameter (mm)	Reel Width W1 (mm)	A0 (mm)	B0 (mm)	K0 (mm)	P1 (mm)	W (mm)	Pin1 Quadrant
TLV320DAC3202CZJR	DSBGA	YZJ	20	3000	180.0	8.4	2.09	2.59	0.78	4.0	8.0	Q2

TAPE AND REEL BOX DIMENSIONS



*All dimensions are nominal

Device	Package Type	Package Drawing	Pins	SPQ	Length (mm)	Width (mm)	Height (mm)
TLV320DAC3202CYZJR	DSBGA	YZJ	20	3000	182.0	182.0	20.0

YZJ (R-XBGA-N20)

DIE-SIZE BALL GRID ARRAY

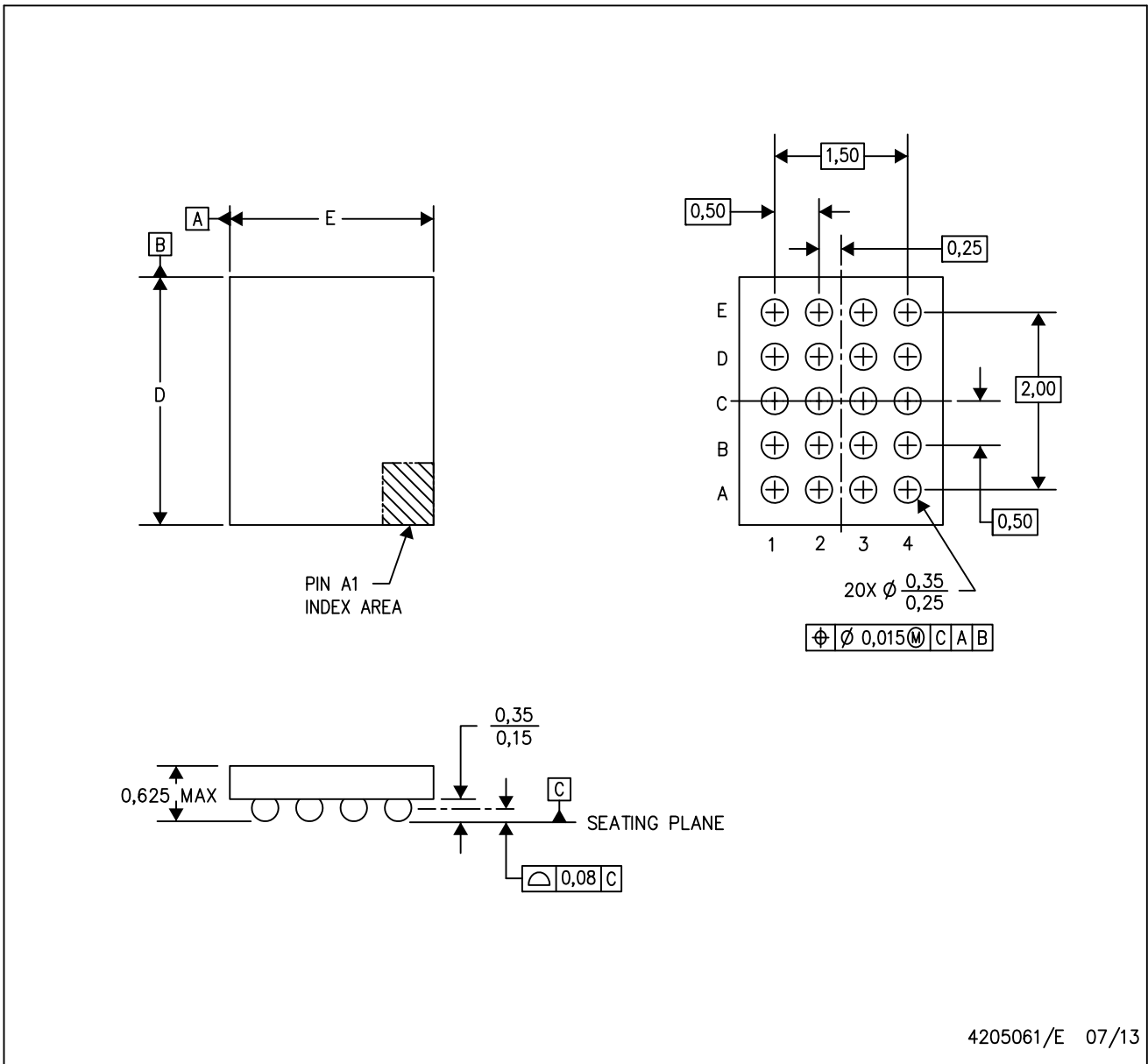

- NOTES:
- A. All linear dimensions are in millimeters.
 - B. This drawing is subject to change without notice.
 - C. NanoFree™ package configuration.

NanoFree is a trademark of Texas Instruments.

IMPORTANT NOTICE

Texas Instruments Incorporated and its subsidiaries (TI) reserve the right to make corrections, enhancements, improvements and other changes to its semiconductor products and services per JESD46, latest issue, and to discontinue any product or service per JESD48, latest issue. Buyers should obtain the latest relevant information before placing orders and should verify that such information is current and complete. All semiconductor products (also referred to herein as "components") are sold subject to TI's terms and conditions of sale supplied at the time of order acknowledgment.

TI warrants performance of its components to the specifications applicable at the time of sale, in accordance with the warranty in TI's terms and conditions of sale of semiconductor products. Testing and other quality control techniques are used to the extent TI deems necessary to support this warranty. Except where mandated by applicable law, testing of all parameters of each component is not necessarily performed.

TI assumes no liability for applications assistance or the design of Buyers' products. Buyers are responsible for their products and applications using TI components. To minimize the risks associated with Buyers' products and applications, Buyers should provide adequate design and operating safeguards.

TI does not warrant or represent that any license, either express or implied, is granted under any patent right, copyright, mask work right, or other intellectual property right relating to any combination, machine, or process in which TI components or services are used. Information published by TI regarding third-party products or services does not constitute a license to use such products or services or a warranty or endorsement thereof. Use of such information may require a license from a third party under the patents or other intellectual property of the third party, or a license from TI under the patents or other intellectual property of TI.

Reproduction of significant portions of TI information in TI data books or data sheets is permissible only if reproduction is without alteration and is accompanied by all associated warranties, conditions, limitations, and notices. TI is not responsible or liable for such altered documentation. Information of third parties may be subject to additional restrictions.

Resale of TI components or services with statements different from or beyond the parameters stated by TI for that component or service voids all express and any implied warranties for the associated TI component or service and is an unfair and deceptive business practice. TI is not responsible or liable for any such statements.

Buyer acknowledges and agrees that it is solely responsible for compliance with all legal, regulatory and safety-related requirements concerning its products, and any use of TI components in its applications, notwithstanding any applications-related information or support that may be provided by TI. Buyer represents and agrees that it has all the necessary expertise to create and implement safeguards which anticipate dangerous consequences of failures, monitor failures and their consequences, lessen the likelihood of failures that might cause harm and take appropriate remedial actions. Buyer will fully indemnify TI and its representatives against any damages arising out of the use of any TI components in safety-critical applications.

In some cases, TI components may be promoted specifically to facilitate safety-related applications. With such components, TI's goal is to help enable customers to design and create their own end-product solutions that meet applicable functional safety standards and requirements. Nonetheless, such components are subject to these terms.

No TI components are authorized for use in FDA Class III (or similar life-critical medical equipment) unless authorized officers of the parties have executed a special agreement specifically governing such use.

Only those TI components which TI has specifically designated as military grade or "enhanced plastic" are designed and intended for use in military/aerospace applications or environments. Buyer acknowledges and agrees that any military or aerospace use of TI components which have **not** been so designated is solely at the Buyer's risk, and that Buyer is solely responsible for compliance with all legal and regulatory requirements in connection with such use.

TI has specifically designated certain components as meeting ISO/TS16949 requirements, mainly for automotive use. In any case of use of non-designated products, TI will not be responsible for any failure to meet ISO/TS16949.

Products

Audio	www.ti.com/audio
Amplifiers	amplifier.ti.com
Data Converters	dataconverter.ti.com
DLP® Products	www.dlp.com
DSP	dsp.ti.com
Clocks and Timers	www.ti.com/clocks
Interface	interface.ti.com
Logic	logic.ti.com
Power Mgmt	power.ti.com
Microcontrollers	microcontroller.ti.com
RFID	www.ti-rfid.com
OMAP Applications Processors	www.ti.com/omap
Wireless Connectivity	www.ti.com/wirelessconnectivity

Applications

Automotive and Transportation	www.ti.com/automotive
Communications and Telecom	www.ti.com/communications
Computers and Peripherals	www.ti.com/computers
Consumer Electronics	www.ti.com/consumer-apps
Energy and Lighting	www.ti.com/energy
Industrial	www.ti.com/industrial
Medical	www.ti.com/medical
Security	www.ti.com/security
Space, Avionics and Defense	www.ti.com/space-avionics-defense
Video and Imaging	www.ti.com/video

TI E2E Community

e2e.ti.com

Looking for pricing, stock, or lifecycle information?

Click below to explore more details on WIN SOURCE:

 [View TLV320DAC3202CZJR on WIN SOURCE](#)

 [Texas Instruments](#) Information

Optimize Your Supply Chain with WIN SOURCE Solutions

-  Global Sourcing Solution
-  Obsolete Management
-  Cost Control Management
-  Shortage Management
-  Alternative Solution
-  Excess Inventory Management