



±1°C TEMPERATURE SENSOR with Series-R, n-Factor, Automatic Beta Compensation and Programmable Addressing

Check for Samples: [TMP435](#)

FEATURES

- ±1°C REMOTE DIODE SENSOR
- ±1°C LOCAL TEMPERATURE SENSOR
- AUTOMATIC BETA COMPENSATION
- n-FACTOR CORRECTION
- PROGRAMMABLE THRESHOLD LIMITS
- TWO-WIRE/ SMBus™ SERIAL INTERFACE
- MINIMUM AND MAXIMUM TEMPERATURE MONITORS
- MULTIPLE INTERFACE ADDRESSES
- ALERT/THERM2 PIN CONFIGURATION
- DIODE FAULT DETECTION
- PIN-PROGRAMMABLE TWO-WIRE ADDRESSING

APPLICATIONS

- LCD/ DLP®/LCOS PROJECTORS
- SERVERS
- INDUSTRIAL CONTROLLERS
- CENTRAL OFFICE TELECOM EQUIPMENT
- DESKTOP AND NOTEBOOK COMPUTERS
- STORAGE AREA NETWORKS (SAN)
- INDUSTRIAL AND MEDICAL EQUIPMENT
- PROCESSOR/FPGA TEMPERATURE MONITORING

DESCRIPTION

The TMP435 is a remote temperature sensor monitor with a built-in local temperature sensor. The remote temperature sensor diode-connected transistors are typically low-cost, NPN- or PNP-type transistors or diodes that are an integral part of microcontrollers, microprocessors, or FPGAs.

Remote accuracy is ±1°C for multiple IC manufacturers, with no calibration needed. The two-wire serial interface accepts SMBus write byte, read byte, send byte, and receive byte commands to program the alarm thresholds and to read temperature data.

The TMP435 includes beta compensation (correction), series resistance cancellation, programmable non-ideality factor, programmable resolution, programmable threshold limits, minimum and maximum temperature monitors, wide remote temperature measurement range (up to +150°C), diode fault detection, a temperature alert function, and pin-programmable two-wire addressing using 3-state logic.

The TMP435 is available in an MSOP-10 package.

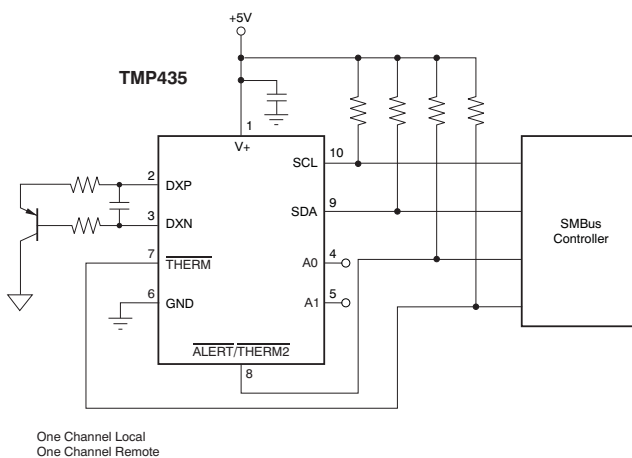

Please be aware that an important notice concerning availability, standard warranty, and use in critical applications of Texas Instruments semiconductor products and disclaimers thereto appears at the end of this data sheet.

DLP is a registered trademark of Texas Instruments.

SMBus is a trademark of Intel Corporation.

All other trademarks are the property of their respective owners.



This integrated circuit can be damaged by ESD. Texas Instruments recommends that all integrated circuits be handled with appropriate precautions. Failure to observe proper handling and installation procedures can cause damage.

ESD damage can range from subtle performance degradation to complete device failure. Precision integrated circuits may be more susceptible to damage because very small parametric changes could cause the device not to meet its published specifications.

PACKAGE INFORMATION⁽¹⁾

| PRODUCT | DESCRIPTION | TWO-WIRE ADDRESS | PACKAGE-LEAD | PACKAGE DESIGNATOR | PACKAGE MARKING |
|---------|------------------------------------|------------------|--------------|--------------------|-----------------|
| TMP435 | Remote Junction Temperature Sensor | Pin-programmable | MSOP-10 | DGS | DTP1 |

(1) For the most current package and ordering information see the Package Option Addendum at the end of this document, or see the TI web site at www.ti.com.

ABSOLUTE MAXIMUM RATINGS⁽¹⁾

Over operating free-air temperature range, unless otherwise noted.

| | | TMP435 | UNIT |
|-----------------------------------|----------------------------|---------------------|------|
| Power Supply, V_S | | +7.0 | V |
| Input Voltage | Pins 2, 3, 4, 5 and 8 only | -0.5 to $V_S + 0.5$ | V |
| | Pins 7, 9, and 10 only | -0.5 to 7 | V |
| Input Current | | 10 | mA |
| Operating Temperature Range | | -55 to +127 | °C |
| Storage Temperature Range | | -60 to +130 | °C |
| Junction Temperature (T_J max) | | +150 | °C |
| ESD Rating | Human Body Model (HBM) | 4000 | V |
| | Charged Device Model (CDM) | 1000 | V |
| | Machine Model (MM) | 200 | V |

(1) Stresses above these ratings may cause permanent damage. Exposure to absolute maximum conditions for extended periods may degrade device reliability. These are stress ratings only, and functional operation of the device at these or any other conditions beyond those specified is not implied.

ELECTRICAL CHARACTERISTICS

 At $T_A = -40^{\circ}\text{C}$ to $+125^{\circ}\text{C}$ and $V_S = 2.7\text{V}$ to 5.5V , unless otherwise noted.

| PARAMETER | CONDITIONS | TMP435 | | | UNIT |
|--|---|--------|--|-----------|-----------------------------|
| | | MIN | TYP | MAX | |
| TEMPERATURE ERROR | | | | | |
| Local Temperature Sensor | $T_{E_{LOCAL}}$ $T_A = -40^{\circ}\text{C}$ to $+125^{\circ}\text{C}$ | | ± 1.25 | ± 2.5 | $^{\circ}\text{C}$ |
| Remote Temperature Sensor ⁽¹⁾ vs Supply (Local/Remote) | $T_{E_{REMOTE}}$ $T_A = +0^{\circ}\text{C}$ to $+100^{\circ}\text{C}$, $V_S = 3.3\text{V}$ | | ± 0.25 | ± 1 | $^{\circ}\text{C}$ |
| | $T_A = 0^{\circ}\text{C}$ to $+100^{\circ}\text{C}$, $T_{DIODE} = -40^{\circ}\text{C}$ to $+150^{\circ}\text{C}$, $V_S = 3.3\text{V}$ | | ± 0.25 | ± 1 | $^{\circ}\text{C}$ |
| | $T_A = -40^{\circ}\text{C}$ to $+100^{\circ}\text{C}$, $T_{DIODE} = -40^{\circ}\text{C}$ to $+150^{\circ}\text{C}$, $V_S = 3.3\text{V}$ | | ± 0.5 | ± 1.5 | $^{\circ}\text{C}$ |
| | $T_A = -40^{\circ}\text{C}$ to $+125^{\circ}\text{C}$, $T_{DIODE} = -40^{\circ}\text{C}$ to $+150^{\circ}\text{C}$ $V_S = 2.7\text{V}$ to 5.5V | | ± 3 | ± 5 | $^{\circ}\text{C}$ |
| | | | ± 0.2 | ± 0.5 | $^{\circ}\text{C}/\text{V}$ |
| TEMPERATURE MEASUREMENT | | | | | |
| Conversion Time (per channel) | | | | | |
| Local Channel | | 12 | 15 | 17 | ms |
| Remote Channel | | | | | |
| Correction Enabled ⁽²⁾ | $RC = 1$ | 97 | 126 | 137 | ms |
| | $RC = 0$ | 36 | 47 | 52 | ms |
| Correction Disabled ⁽³⁾ | $RC = 1$ | 72 | 93 | 100 | ms |
| | $RC = 0$ | 33 | 44 | 47 | ms |
| Resolution | | | | | |
| Local Channel | | | 12 | | Bits |
| Remote Channel | | | 12 | | Bits |
| Remote Sensor Source Currents | | | | | |
| High | Series Resistance (beta correction) ⁽⁴⁾ | | 120 | | μA |
| Medium High | | | 60 | | μA |
| Medium Low | | | 12 | | μA |
| Low | | | 6 | | μA |
| Remote Transistor Ideality Factor | n TMP435 optimized ideality factor | | 1.000 ⁽²⁾ 1.008 ⁽³⁾ | | |
| Beta Correction Range | β | 0.1 | | 27 | |
| SMBus INTERFACE | | | | | |
| Logic Input High Voltage (SCL, SDA) | V_{IH} | 2.1 | | | V |
| Logic Input Low Voltage (SCL, SDA) | V_{IL} | | | 0.8 | V |
| Hysteresis | | | 500 | | mV |
| SMBus Output Low Sink Current | | 6 | | | mA |
| SDA Output Low Voltage | V_{OL} $I_{OUT} = 6\text{mA}$ | | 0.15 | 0.4 | V |
| Logic Input Current | $0 \leq V_{IN} \leq 6\text{V}$ | -1 | | +1 | μA |
| SMBus Input Capacitance (SCL, SDA) | | | 3 | | pF |
| SMBus Clock Frequency | | | | 3.4 | MHz |
| SMBus Timeout | | 25 | 32 | 35 | ms |
| SCL Falling Edge to SDA Valid Time | | | | 1 | μs |
| DIGITAL OUTPUTS | | | | | |
| Output Low Voltage | V_{OL} $I_{OUT} = 6\text{mA}$ | | 0.15 | 0.4 | V |
| High-Level Output Leakage Current | I_{OH} $V_{OUT} = V_S$ | | 0.1 | 1 | μA |
| $\overline{\text{ALERT}}/\overline{\text{THERM2}}$ Output Low Sink Current | $\overline{\text{ALERT}}/\overline{\text{THERM2}}$ Forced to 0.4V | 6 | | | mA |
| $\overline{\text{THERM}}$ Output Low Sink Current | $\overline{\text{THERM2}}$ Forced to 0.4V | 6 | | | mA |

- (1) Tested with less than 5Ω effective series resistance and 100pF differential input capacitance. T_A is the ambient temperature of the TMP435. T_{DIODE} is the temperature at the remote diode sensor.
- (2) Beta correction configuration set to '1000' and sensor is GND collector-connected (PNP collector to ground).
- (3) Beta correction configuration set to '0111' or sensor is diode-connected (base shorted to collector).
- (4) If beta correction is disabled ('0111'), then up to $1\text{k}\Omega$ of series line resistance is cancelled; if beta correction is enabled ('1xxx'), up to 300Ω is cancelled.

ELECTRICAL CHARACTERISTICS (continued)

At $T_A = -40^{\circ}\text{C}$ to $+125^{\circ}\text{C}$ and $V_S = 2.7\text{V}$ to 5.5V , unless otherwise noted.

| PARAMETER | CONDITIONS | TMP435 | | | UNIT | |
|-----------------------------|---------------|--------|--|------|-----------------------------|---------------|
| | | MIN | TYP | MAX | | |
| POWER SUPPLY | | | | | | |
| Specified Voltage Range | V_S | 2.7 | | 5.5 | V | |
| Quiescent Current | I_Q | | 0.0625 Conversions per Second, $V_S = 3.3\text{V}$ | 35 | 45 | μA |
| | | | Eight Conversions per Second, $V_S = 3.3\text{V}^{(5)}$ | 0.7 | 1 | mA |
| | | | Serial Bus Inactive, Shutdown Mode | 3 | 10 | μA |
| | | | Serial Bus Active, $f_S = 400\text{kHz}$, Shutdown Mode | 90 | | μA |
| | | | Serial Bus Active, $f_S = 3.4\text{MHz}$, Shutdown Mode | 350 | | μA |
| Undervoltage Lockout | UVLO | 2.3 | 2.4 | 2.6 | V | |
| Power-On Reset Threshold | POR | | 1.6 | 2.3 | V | |
| TEMPERATURE RANGE | | | | | | |
| Specified Range | | -40 | | +125 | $^{\circ}\text{C}$ | |
| Storage Range | | -60 | | +130 | $^{\circ}\text{C}$ | |
| Thermal Resistance, MSOP-10 | θ_{JA} | | 165 | | $^{\circ}\text{C}/\text{W}$ | |

(5) Beta correction disabled.

DEVICE INFORMATION

DGS PACKAGE MSOP-10 (TOP VIEW)

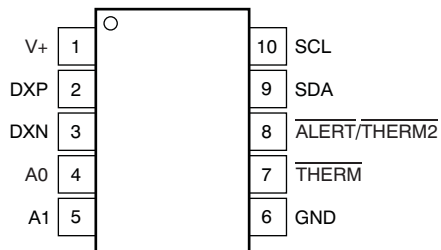

PIN ASSIGNMENTS

| TMP435 | | DESCRIPTION |
|--------|----------------------------------|--|
| NO. | NAME | |
| 1 | V+ | Positive supply (2.7V to 5.5V) |
| 2 | DXP | Positive connection to remote temperature sensor |
| 3 | DXN | Negative connection to remote temperature sensor |
| 4 | A0 | Address pin 0 |
| 5 | A1 | Address pin 1 |
| 6 | GND | Ground |
| 7 | $\overline{\text{THERM}}$ | Thermal flag, active low, open-drain; requires pull-up resistor to V+ |
| 8 | $\overline{\text{ALERT/THERM2}}$ | Alert (reconfigurable as second thermal flag), active low, open-drain; requires pull-up resistor to V+ |
| 9 | SDA | Serial data line for SMBus, open-drain; requires pull-up resistor to V+ |
| 10 | SCL | Serial clock line for SMBus, open-drain; requires pull-up resistor to V+ |

TYPICAL CHARACTERISTICS

At $T_A = +25^\circ\text{C}$ and $V_S = 3.3\text{V}$, unless otherwise noted.

REMOTE TEMPERATURE ERROR vs TEMPERATURE

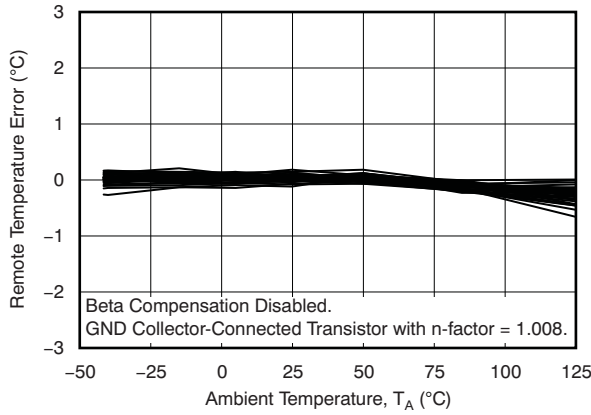

Figure 1.

LOCAL TEMPERATURE ERROR vs TEMPERATURE

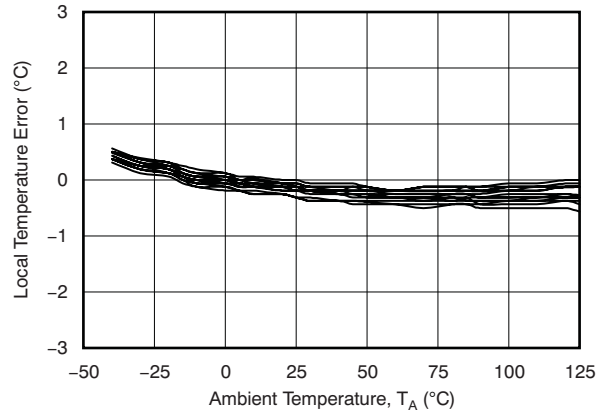

Figure 2.

REMOTE TEMPERATURE ERROR vs LEAKAGE RESISTANCE

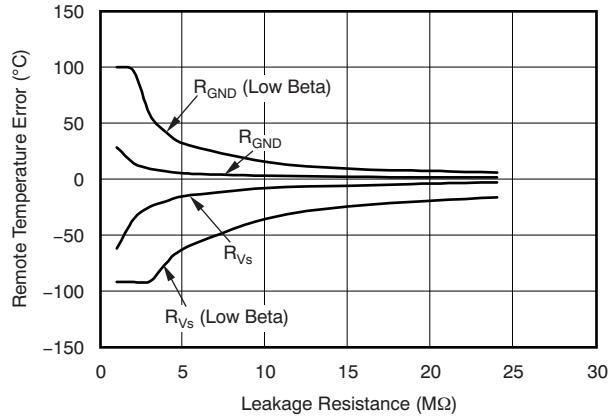

Figure 3.

QUIESCENT CURRENT vs CONVERSION RATE

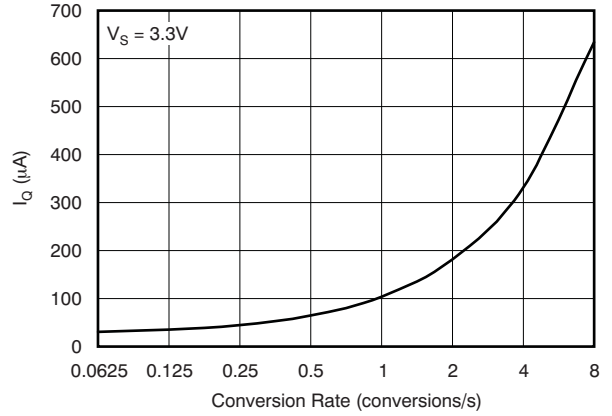

Figure 4.

SHUTDOWN QUIESCENT CURRENT vs SCL CLOCK FREQUENCY

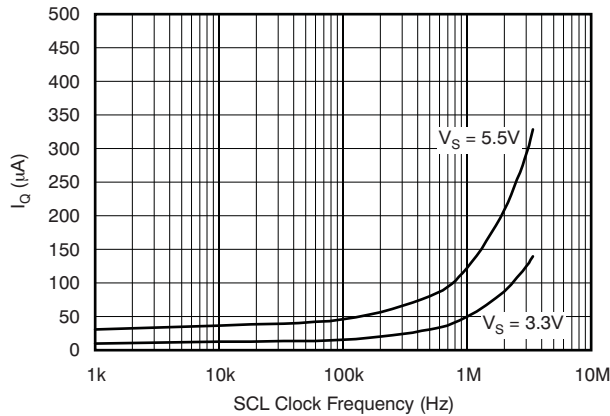

Figure 5.

SHUTDOWN QUIESCENT CURRENT vs SUPPLY VOLTAGE

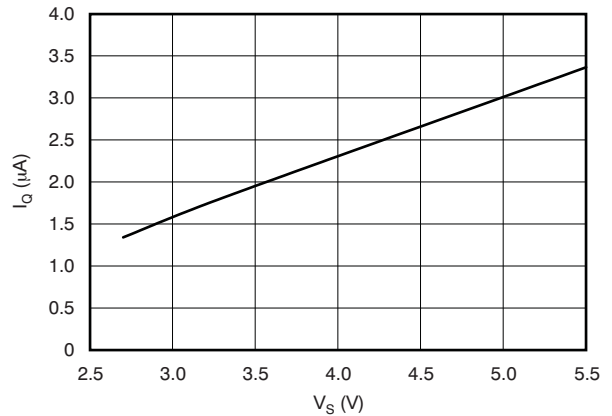

Figure 6.

TYPICAL CHARACTERISTICS (continued)

At $T_A = +25^\circ\text{C}$ and $V_S = 3.3\text{V}$, unless otherwise noted.

REMOTE TEMPERATURE ERROR vs SERIES RESISTANCE

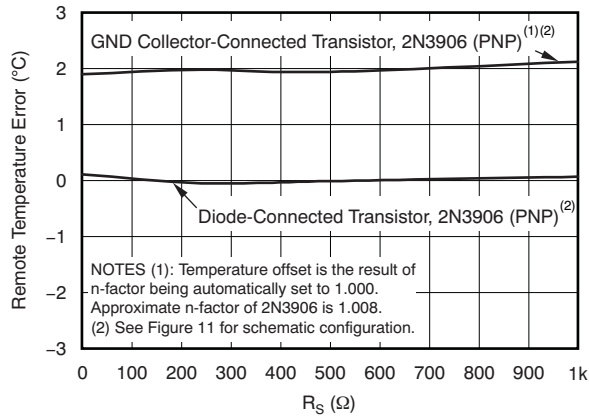

Figure 7.

REMOTE TEMPERATURE ERROR vs SERIES RESISTANCE (Low-Beta Transistor)

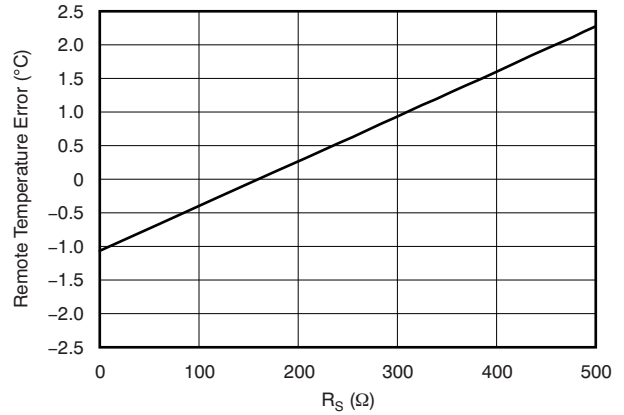

Figure 8.

REMOTE TEMPERATURE ERROR vs DIFFERENTIAL CAPACITANCE AT +25°C, $V_{CC} = 3.3\text{V}$, $R_S = 0\Omega$

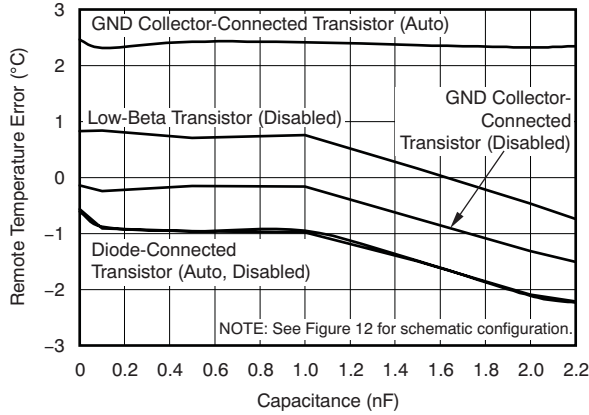

Figure 9.

REMOTE TEMPERATURE ERROR vs DIFFERENTIAL CAPACITANCE with 45nm CPU AT +25°C, $V_{CC} = 3.3\text{V}$, $R_S = 0\Omega$, Beta = 011 (AUTO)

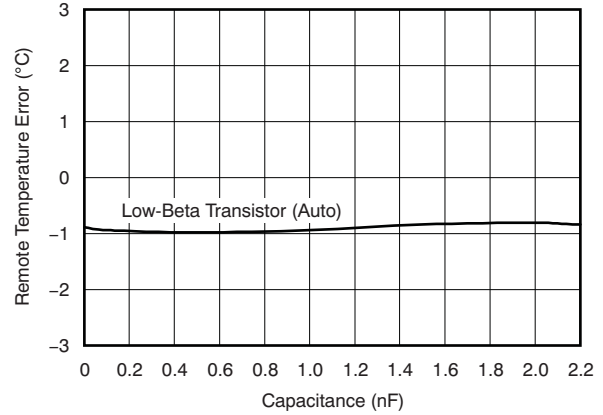

Figure 10.

PARAMETRIC MEASUREMENT INFORMATION

TEST CIRCUITS

SERIES RESISTANCE CONFIGURATION

(a) GND Collector-Connected Transistor

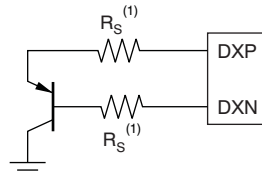

(b) Diode-Connected Transistor

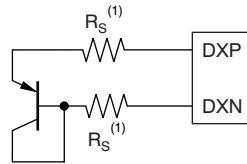

(1) R_s should be less than 1k Ω ; see [Filtering](#) section.

Figure 11.

DIFFERENTIAL CAPACITANCE CONFIGURATION

(a) GND Collector-Connected Transistor

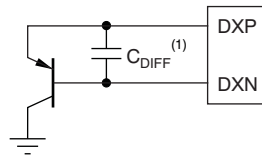

(b) Diode-Connected Transistor

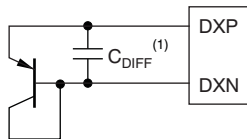

(1) C_{DIFF} should be less than 2200pF; see [Filtering](#) section.

Figure 12.

APPLICATION INFORMATION

The TMP435 (two-channel) is a digital temperature sensor that combines a local die temperature measurement channel and a remote junction temperature measurement channel in a single package. This device is two-wire- and SMBus interface-compatible, and is specified over a temperature range of -40°C to $+125^{\circ}\text{C}$. The TMP435 contains multiple registers for holding configuration information, temperature measurement results, temperature comparator maximum/minimum limits, and status information. User-programmed high and low temperature limits stored in the TMP435 can be used to trigger an over/under temperature alarm ($\overline{\text{ALERT}}$) on local and remote temperatures. Additional thermal limits can be programmed into the TMP435 and used to trigger another flag ($\overline{\text{THERM}}$) that can be used to initiate a system response to rising temperatures.

For proper remote temperature sensing operation, the TMP435 requires only a transistor connected between DXP and DXN.

The SCL and SDA interface pins require pull-up resistors as part of the communication bus, while $\overline{\text{ALERT}}$ and $\overline{\text{THERM}}$ are open-drain outputs that also need pull-up resistors. $\overline{\text{ALERT}}$ and $\overline{\text{THERM}}$ may be shared with other devices if desired for a wired-OR implementation. A $0.1\mu\text{F}$ power-supply bypass capacitor is recommended for good local bypassing. See [Figure 13](#) for a typical configuration.

Beta Compensation

Previous generations of remote junction temperature sensors were operated by controlling the emitter current of the sensing transistor. However, examination of the physics of a transistor shows that V_{BE} is actually a function of the collector current. If beta is independent of the collector current, then V_{BE} may be calculated from the emitter current. In earlier generations of processors that contained PNP transistors connected to these temperature sensors, controlling the emitter current provided acceptable temperature measurement results. At 90nm process geometry and below, the beta factor continues to decrease and the premise that it is independent of collector current becomes less certain.

To manage this increasing temperature measurement error, the TMP435 controls the collector current instead of the emitter current. The TMP435 automatically detects and chooses the correct range depending on the beta factor of the external transistor. This auto-ranging is performed at the beginning of each temperature conversion in order to

correct for any changes in the beta factor as a result of temperature variation. The device can operate a PNP transistor with a beta factor as low as 0.1. See the [Beta Compensation Configuration Register](#) section for further information.

Series Resistance Cancellation

Series resistance in an application circuit that typically results from printed circuit board (PCB) trace resistance and remote line length is automatically cancelled by the TMP435, preventing what would otherwise result in a temperature offset. A total of up to $1\text{k}\Omega$ of series line resistance is cancelled by the TMP435 if beta correction is disabled and up to 300Ω of series line resistance is canceled if beta correction is enabled, eliminating the need for additional characterization and temperature offset correction. See the two [Remote Temperature Error vs Series Resistance](#) typical characteristic curves ([Figure 7](#) and [Figure 8](#)) for details on the effect of series resistance on sensed remote temperature error.

Differential Input Capacitance

The TMP435 can tolerate differential input capacitance of up to 2200pF with minimal change in temperature error. The effect of capacitance on sensed remote temperature error is illustrated in [Figure 9](#) and [Figure 10](#), [Remote Temperature Error vs Differential Capacitance](#). See the [Filtering](#) section for suggested component values where filtering unwanted coupled signals is needed.

Temperature Measurement Data

Temperature measurement data are taken over a default range of 0°C to $+127^{\circ}\text{C}$ for both local and remote locations. However, measurements from -55°C to $+150^{\circ}\text{C}$ can be made both locally and remotely by reconfiguring the TMP435 for the extended temperature range, as described in this section. Temperature data resulting from conversions within the default measurement range are represented in binary form, as shown in [Table 1](#), [Standard Binary](#) column. Note that any temperature below 0°C results in a data value of zero (00h). Likewise, temperatures above $+127^{\circ}\text{C}$ result in a value of 127 (7Fh). The device can be set to measure over an extended temperature range by changing bit 2 (RANGE) of Configuration Register 1 from low to high. The change in measurement range and data format from standard binary to extended binary occurs at the next temperature conversion.

For data captured in the extended temperature range configuration, an offset of 64 (40h) is added to the standard binary value, as shown in [Table 1, Extended Binary](#) column. This configuration allows measurement of temperatures as low as -64°C , and as high as $+191^{\circ}\text{C}$; however, most temperature-sensing diodes only measure with the range of -55°C to $+150^{\circ}\text{C}$.

Additionally, the TMP435 is rated only for ambient local temperatures ranging from -40°C to $+125^{\circ}\text{C}$. Parameters in the [Absolute Maximum Ratings](#) table must be observed.

Both local and remote temperature data use two bytes for data storage. The high byte stores the temperature with 1°C resolution. The second or low byte stores the decimal fraction value of the temperature and allows a higher measurement resolution, as shown in [Table 2](#).

The measurement resolution for both the local and remote channels is 0.0625°C , and cannot be adjusted.

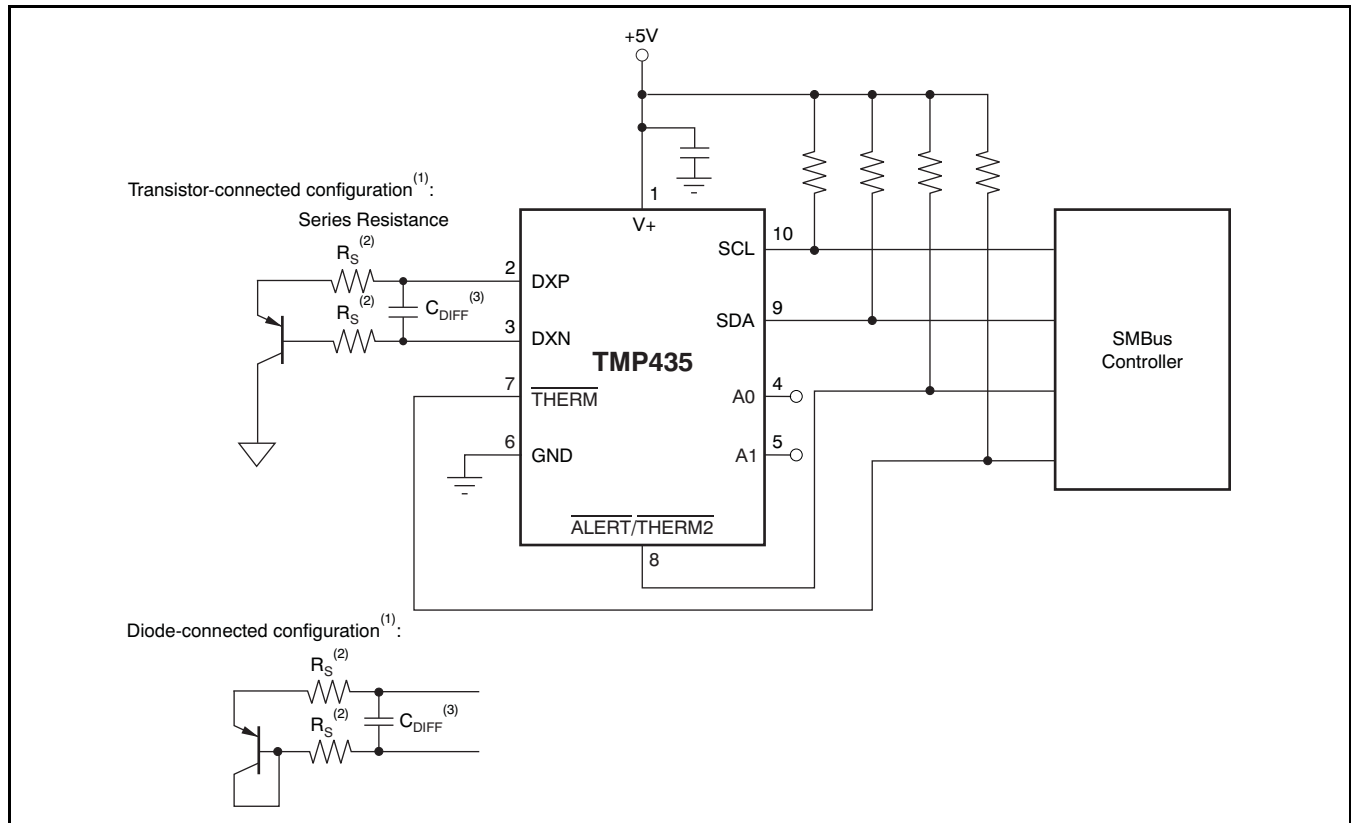

- (1) Diode-connected configuration provides better settling time. Transistor-connected configuration provides better series resistance cancellation.
- (2) R_S (optional) should be $< 1\text{k}\Omega$ in most applications. Selection of R_S depends on specific application; see [Filtering](#) section.
- (3) C_{DIFF} (optional) should be $< 2200\text{pF}$ in most applications. Selection of C_{DIFF} depends on specific application; see [Filtering](#) section and [Figure 9, Remote Temperature Error vs Differential Capacitance](#).

Figure 13. TMP435 Basic Connections

Table 1. Temperature Data Format (Local and Remote Temperature High Bytes)

| TEMP (°C) | LOCAL/REMOTE TEMPERATURE REGISTER HIGH BYTE VALUE (+1°C RESOLUTION) | | | |
|-----------|--|-----|--------------------------------|-----|
| | STANDARD BINARY ⁽¹⁾ | | EXTENDED BINARY ⁽²⁾ | |
| | BINARY | HEX | BINARY | HEX |
| -64 | 0000 0000 | 00 | 0000 0000 | 00 |
| -50 | 0000 0000 | 00 | 0000 1110 | 0E |
| -25 | 0000 0000 | 00 | 0010 0111 | 27 |
| 0 | 0000 0000 | 00 | 0100 0000 | 40 |
| 1 | 0000 0001 | 01 | 0100 0001 | 41 |
| 5 | 0000 0101 | 05 | 0100 0101 | 45 |
| 10 | 0000 1010 | 0A | 0100 1010 | 4A |
| 25 | 0001 1001 | 19 | 0101 1001 | 59 |
| 50 | 0011 0010 | 32 | 0111 0010 | 72 |
| 75 | 0100 1011 | 4B | 1000 1011 | 8B |
| 100 | 0110 0100 | 64 | 1010 0100 | A4 |
| 125 | 0111 1101 | 7D | 1011 1101 | BD |
| 127 | 0111 1111 | 7F | 1011 1111 | BF |
| 150 | 0111 1111 | 7F | 1101 0110 | D6 |
| 175 | 0111 1111 | 7F | 1110 1111 | EF |
| 191 | 0111 1111 | 7F | 1111 1111 | FF |

- (1) Resolution is 1°C/count. Negative numbers are represented in twos complement format.
- (2) Resolution is 1°C/count. All values are unsigned with a -64°C offset.

Table 2. Decimal Fraction Temperature Data Format (Local and Remote Temperature Low Bytes)

| TEMP (°C) | TEMPERATURE REGISTER LOW BYTE VALUE (0.0625°C RESOLUTION) ⁽¹⁾ | |
|-----------|---|-----|
| | STANDARD AND EXTENDED BINARY | HEX |
| 0 | 0000 0000 | 00 |
| 0.0625 | 0001 0000 | 10 |
| 0.1250 | 0010 0000 | 20 |
| 0.1875 | 0011 0000 | 30 |
| 0.2500 | 0100 0000 | 40 |
| 0.3125 | 0101 0000 | 50 |
| 0.3750 | 0110 0000 | 60 |
| 0.4375 | 0111 0000 | 70 |
| 0.5000 | 1000 0000 | 80 |
| 0.5625 | 1001 0000 | 90 |
| 0.6250 | 1010 0000 | A0 |
| 0.6875 | 1011 0000 | B0 |
| 0.7500 | 1100 0000 | C0 |
| 0.8125 | 1101 0000 | D0 |
| 0.8750 | 1110 0000 | E0 |
| 0.9375 | 1111 0000 | F0 |

- (1) Resolution is 0.0625°C/count. All possible values are shown.

REGISTER INFORMATION

The TMP435 contain multiple registers for holding configuration information, temperature measurement results, temperature comparator maximum/minimum, limits, and status information. These registers are described in Figure 14 and in Table 3.

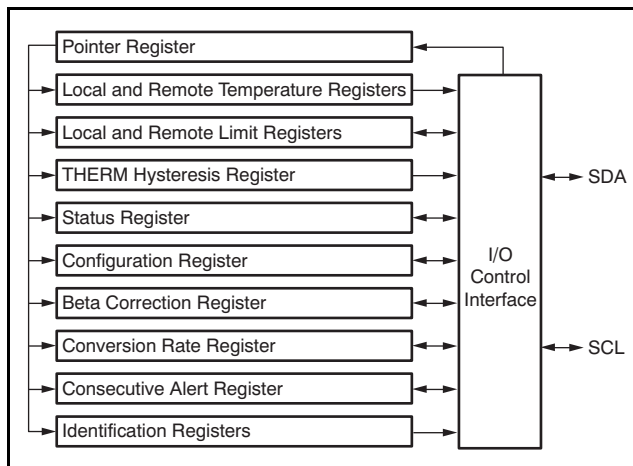

Figure 14. Internal Register Structure

Table 3. TMP435 Register Map

| POINTER ADDRESS (HEX) | | POWER-ON RESET (HEX) | BIT DESCRIPTIONS | | | | | | | | REGISTER DESCRIPTIONS |
|-----------------------|-------------------|----------------------|------------------|-------|--------------------|-------|-------|-------|--------|-------|---|
| READ | WRITE | | D7 | D6 | D5 | D4 | D3 | D2 | D1 | D0 | |
| 00 | NA ⁽¹⁾ | 00 | LT11 | LT10 | LT9 | LT8 | LT7 | LT6 | LT5 | LT4 | Local Temperature (High Byte) |
| 01 | NA | 00 | RT11 | RT10 | RT9 | RT8 | RT7 | RT6 | RT5 | RT4 | Remote Temperature (High Byte) |
| 02 | NA | 80 | BUSY | LHIGH | LLOW | RHIGH | RLOW | OPEN | RTHRM | LTHRM | Status Register |
| 03 | 09 | 00 | MASK | SD | \overline{AL}/TH | 0 | 0 | RANGE | 0 | 0 | Configuration Register 1 |
| 04 | 0A | 07 | 0 | 0 | 0 | 0 | R3 | R2 | R1 | R0 | Conversion Rate Register |
| 05 | 0B | 55 | LTH11 | LTH10 | LTH9 | LTH8 | LTH7 | LTH6 | LTH5 | LTH4 | Local Temperature High Limit (High Byte) |
| 06 | 0C | 00 | LTL11 | LTL10 | LTL9 | LTL8 | LTL7 | LTL6 | LTL5 | LTL4 | Local Temperature Low Limit (High Byte) |
| 07 | 0D | 55 | RTH11 | RTH10 | RTH9 | RTH8 | RTH7 | RTH6 | RTH5 | RTH4 | Remote Temperature High Limit (High Byte) |
| 08 | 0E | 00 | RTL11 | RTL10 | RTL9 | RTL8 | RTL7 | RTL6 | RTL5 | RTL4 | Remote Temperature Low Limit (High Byte) |
| NA | 0F | XX | X ⁽²⁾ | X | X | X | X | X | X | X | One-Shot Start |
| 10 | NA | 00 | RT3 | RT2 | RT1 | RT0 | 0 | 0 | 0 | 0 | Remote Temperature (Low Byte) |
| 13 | 13 | 00 | RTH3 | RTH2 | RTH1 | RTH0 | 0 | 0 | 0 | 0 | Remote Temperature High Limit (Low Byte) |
| 14 | 14 | 00 | RTL3 | RTL2 | RTL1 | RTL0 | 0 | 0 | 0 | 0 | Remote Temperature Low Limit (Low Byte) |
| 15 | NA | 00 | LT3 | LT2 | LT1 | LT0 | 0 | 0 | 0 | 0 | Local Temperature (Low Byte) |
| 16 | 16 | 00 | LTH3 | LTH2 | LTH1 | LTH0 | 0 | 0 | 0 | 0 | Local Temperature High Limit (Low Byte) |
| 17 | 17 | 00 | LTL3 | LTL2 | LTL1 | LTL0 | 0 | 0 | 0 | 0 | Local Temperature Low Limit (Low Byte) |
| 18 | 18 | 00 | NC7 | NC6 | NC5 | NC4 | NC3 | NC2 | NC1 | NC0 | n-Factor Correction |
| 19 | 19 | 55 | RTHL7 | RTHL6 | RTHL5 | RTHL4 | RTHL3 | RTHL2 | RTHL1 | RTHL0 | Remote THERM Limit |
| 1A | 1A | 1C | 0 | 0 | 0 | REN | LEN | RC | 0 | 0 | Configuration Register 2 |
| 1F | 1F | 00 | 0 | 0 | 0 | 0 | 0 | 0 | RIMASK | LMASK | Channel Mask |
| 20 | 20 | 55 | LTHL7 | LTHL6 | LTHL5 | LTHL4 | LTHL3 | LTHL2 | LTHL1 | LTHL0 | Local THERM Limit |
| 21 | 21 | 0A | TH7 | TH6 | TH5 | TH4 | TH3 | TH2 | TH1 | TH0 | THERM Hysteresis |
| 22 | 22 | 70 | 0 | CTH2 | CTH1 | CTH0 | CALT2 | CALT1 | CALT0 | 0 | Consecutive Alert Register |
| 25 | 25 | 08 | 0 | 0 | 0 | 0 | BC3 | BC2 | BC1 | BC0 | Beta Range Register |
| NA | FC | 00 | X ⁽³⁾ | X | X | X | X | X | X | X | Software Reset |
| FD | NA | 31 | 0 | 0 | 1 | 1 | 0 | 0 | 0 | 1 | TMP435 Device ID |
| FE | NA | 55 | 0 | 1 | 0 | 1 | 0 | 1 | 0 | 1 | Manufacturer ID |

- (1) NA = Not applicable; register is write- or read-only.
- (2) X = Indeterminate state.
- (3) X = Undefined. Writing any value to this register initiates a software reset; see the [Software Reset](#) section.

Pointer Register

Figure 14 shows the internal register structure of the TMP435. The 8-bit Pointer Register is used to address a given data register. The Pointer Register identifies which of the data registers should respond to a read or write command on the two-wire bus. This register is set with every write command. A write command must be issued to set the proper value in the Pointer Register before executing a read command. Table 3 describes the pointer address of the registers available in the TMP435. The power-on reset (POR) value of the Pointer Register is 00h (0000 0000b).

Temperature Registers

The TMP435 has four 8-bit registers that hold temperature measurement results. Both the local channel and the remote channel have a high byte register that contains the most significant bits (MSBs) of the temperature analog-to-digital converter (ADC) result and a low byte register that contains the least significant bits (LSBs) of the temperature ADC result. The local channel high byte address for the TMP435 is 00h; the local channel low byte address is 15h. The remote channel high byte is at address 01h; the remote channel low byte address is 10h. These registers are read-only and are updated by the ADC each time a temperature measurement is completed.

The TMP435 contains circuitry to assure that a low byte register read command returns data from the same analog-to-digital (A/D) conversion as the immediately preceding high byte read command. This assurance remains valid only until another register is read. For proper operation, the high byte of a temperature register should be read first. The low byte register should be read in the next read command. The low byte register may be left unread if the LSBs are not needed. Alternatively, the temperature registers may be read as a 16-bit register by using a single two-byte read command from address 00h for the local channel result, or from address 01h for the remote channel result (23h for the second remote channel result). The high byte is output first, followed by the low byte. Both bytes of this read operation are from the same A/D conversion. The power-on reset value of both temperature registers is 00h.

Limit Registers

The TMP435 has registers for setting comparator limits for both the local and remote measurement channels. These registers have read and write capability. The High and Low Limit Registers for both channels span two registers, as do the temperature registers. The local temperature high limit is set by writing the high byte to pointer address 0Bh and writing the low byte to pointer address 16h, or by using a single two-byte write command (high byte first) to pointer address 0Bh.

The local temperature high limit is obtained by reading the high byte from pointer address 05h and the low byte from pointer address 16h, or by using a two-byte read command from pointer address 05h. The power-on reset value of the local temperature high limit is 55h/00h (+85°C in standard temperature mode; +21°C in extended temperature mode).

Similarly, the local temperature low limit is set by writing the high byte to pointer address 0Ch and writing the low byte to pointer address 17h, or by using a single two-byte write command to pointer address 0Ch. The local temperature low limit is read by reading the high byte from pointer address 06h and the low byte from pointer address 17h, or by using a two-byte read from pointer address 06h. The power-on reset value of the local temperature low limit register is 00h/00h (0°C in standard temperature mode; –64°C in extended mode).

The remote temperature high limit for the TMP435 is set by writing the high byte to pointer address 0Dh and writing the low byte to pointer address 13h, or by using a two-byte write command to pointer address 0Dh. The remote temperature high limit is obtained by reading the high byte from pointer address 07h and the low byte from pointer address 13h, or by using a two-byte read command from pointer address 07h. The power-on reset value of the Remote Temperature High Limit Register is 55h/00h (+85°C in standard temperature mode; +21°C in extended temperature mode).

The remote temperature low limit for the TMP435 is set by writing the high byte to pointer address 0Eh and writing the low byte to pointer address 14h, or by using a two-byte write to pointer address 0Eh. The remote temperature low limit is read by reading the high byte from pointer address 08h and the low byte from pointer address 14h, or by using a two-byte read from pointer address 08h. The power-on reset value of the Remote Temperature Low Limit Register is 00h/00h (0°C in standard temperature mode; –64°C in extended mode).

The TMP435 also has a THERM limit register for both the local and the remote channels. These are 8-bit registers and allow for THERM limits set to 1°C resolution. The local channel THERM limit is set by writing to pointer address 20h. The remote channel THERM limit is set by writing to pointer address 19h.

The local channel THERM limit is obtained by reading from pointer address 20h; the remote channel THERM limit is read by reading from pointer address 19h. The power-on reset value of the THERM limit registers is 55h (+85°C in standard temperature mode; +21°C in extended temperature mode). The THERM limit comparators also have hysteresis. The hysteresis of both comparators is set by writing to pointer address 21h. The hysteresis value is obtained by reading from pointer address 21h. The value in the Hysteresis Register is an unsigned number (always positive). The power-on reset value of this register is 0Ah (+10°C).

Whenever changing between standard and extended temperature ranges, be aware that the temperatures stored in the temperature limit registers are **NOT** automatically reformatted to correspond to the new temperature range format. These values must be reprogrammed in the appropriate binary or extended binary format.

Status Register

The TMP435 has a Status Register to report the state of the temperature comparators. [Table 4](#) shows the Status Register bits. The Status Register is read-only and is read by reading from pointer address 02h.

The BUSY bit reads as ‘1’ if the ADC is making a conversion. It reads as ‘0’ if the ADC is not converting.

The OPEN bit reads as ‘1’ if the remote transistor was detected as open since the last read of the Status Register. The OPEN status is only detected when the ADC attempts to convert a remote temperature.

The RTHRM bit reads as ‘1’ if the remote temperature has exceeded the remote THERM limit and remains greater than the remote THERM limit less the value in the shared Hysteresis Register; see [Figure 20](#).

The LTHRM bit reads as ‘1’ if the local temperature has exceeded the local THERM limit and remains greater than the local THERM limit less the value in the shared Hysteresis Register; see [Figure 20](#).

Table 4. TMP435 Status Register Format

| TMP435 STATUS REGISTER (Read = 02h, Write = NA) | | | | | | | | |
|---|------------------|-------|------|-------|------|------|-------|-------|
| BIT # | D7 | D6 | D5 | D4 | D3 | D2 | D1 | D0 |
| BIT NAME | BUSY | LHIGH | LLOW | RHIGH | RLOW | OPEN | RTHRM | LTHRM |
| POR VALUE | 0 ⁽¹⁾ | 0 | 0 | 0 | 0 | 0 | 0 | 0 |

(1) The BUSY bit changes to ‘1’ almost immediately (<< 100µs) following power-up, as the TMP435 begins the first temperature conversion. It is high whenever the TMP435 is converting a temperature reading.

The **LHIGH** and **RHIGH** bit values depend on the state of the **AL/TH** bit in the Configuration Register. If the **AL/TH** bit is '0', the **LHIGH** bit reads as '1' if the local high limit was exceeded since the last clearing of the Status Register. The **RHIGH** bit reads as '1' if the remote high limit was exceeded since the last clearing of the Status Register. If the **AL/TH** bit is '1', the remote high limit and the local high limit are used to implement a **THERM2** function. **LHIGH** reads as '1' if the local temperature has exceeded the local high limit and remains greater than the local high limit less the value in the Hysteresis Register.

The **RHIGH** bit reads as '1' if the remote temperature has exceeded the remote high limit and remains greater than the remote high limit less the value in the Hysteresis Register.

The **LLOW** and **RLOW** bits are not affected by the **AL/TH** bit. The **LLOW** bit reads as '1' if the local low limit was exceeded since the last clearing of the Status Register. The **RLOW** bit reads as '1' if the remote low limit was exceeded since the last clearing of the Status Register.

The values of the **LLOW**, **RLOW**, and **OPEN** (as well as **LHIGH** and **RHIGH** when **AL/TH** is '0') are latched and read as '1' until the Status Register is read or a device reset occurs. These bits are cleared by reading the Status Register, provided that the condition causing the flag to be set no longer exists. The values of **BUSY**, **LTHRM**, and **RTHRM** (as well as **LHIGH** and **RHIGH** when **ALERT/THERM2** is '1') are not latched and are not cleared by reading the Status Register. They always indicate the current state, and are updated appropriately at the end of the corresponding A/D conversion. Clearing the **Status Register** bits does not clear the state of the **ALERT** pin; an **SMBus alert response** address command must be used to clear the **ALERT** pin.

The **TMP435** **NORs**, **LHIGH**, **LLOW**, **RHIGH**, **RLOW**, and **OPEN**, so a status change for any of these flags from '0' to '1' automatically causes the **ALERT** pin to go low (only applies when the **ALERT/THERM2** pin is configured for **ALERT** mode).

Configuration Register 1

Configuration Register 1 sets the temperature range, controls shutdown mode, and determines how the **ALERT/THERM2** pin functions. This Configuration Register is set by writing to pointer address 09h and read by reading from pointer address 03h.

The **MASK** bit (bit 7) enables or disables the **ALERT** pin output if **ALERT/THERM2** = 0. If **ALERT/THERM2** = 1 then the **MASK** bit has no effect. If **MASK** is set to '0', the **ALERT** pin goes low when one of the temperature measurement channels exceeds its high or low limits for the chosen number of consecutive conversions. If the **MASK** bit is set to '1', the **TMP435** retains the **ALERT** pin status, but the **ALERT** pin does not go low.

The shutdown (**SD**) bit (bit 6) enables or disables the temperature measurement circuitry. If **SD** = 0, the **TMP435** converts continuously at the rate set in the conversion rate register. When **SD** is set to '1', the **TMP435** immediately stops converting and enters a shutdown mode. When **SD** is set to '0' again, the **TMP435** resumes continuous conversions. A single conversion can be started when **SD** = 1 by writing to the One-Shot Register.

The **AL/TH** bit (bit 5) controls whether the **ALERT** pin functions in **ALERT** mode or **THERM2** mode. If **AL/TH** = 0, the **ALERT** pin operates as an interrupt pin. In this mode, the **ALERT** pin goes low after the set number of consecutive out-of-limit temperature measurements occur.

If **AL/TH** = 1, the **ALERT/THERM2** pin implements a **THERM** function (**THERM2**). In this mode, **THERM2** functions similar to the **THERM** pin except that the local high limit and remote high limit registers are used for the thresholds. **THERM2** goes low when either **RHIGH** or **LHIGH** is set.

The temperature range is set by configuring bit 2 of Configuration Register 1. Setting this bit low configures the **TMP435** for the standard measurement range (0°C to +127°C); temperature conversions are stored in the standard binary format. Setting bit 2 high configures the **TMP435** for the extended measurement range (-55°C to +150°C); temperature conversions are stored in the extended binary format (see [Table 1](#)).

The remaining bits of Configuration Register 1 are reserved and must always be set to '0'. The power-on reset value for this register is 00h. [Table 5](#) summarizes the bits of Configuration Register 1.

Table 5. Configuration Register 1 Bit Descriptions

| CONFIGURATION REGISTER 1 (Read = 03h, Write = 09h, POR = 00h) | | | |
|--|--------------------|--|----------------------|
| BIT | NAME | FUNCTION | POWER-ON RESET VALUE |
| 7 | MASK | 0 = ALERT Enabled 1 = ALERT Masked | 0 |
| 6 | SD | 0 = Run 1 = Shut Down | 0 |
| 5 | \overline{AL}/TH | 0 = ALERT Mode 1 = THERM Mode | 0 |
| 4, 3 | Reserved | — | 0 |
| 2 | Temperature Range | 0 = 0°C to +127°C 1 = -55°C to +150°C | 0 |
| 1, 0 | Reserved | — | 0 |

Configuration Register 2

Configuration Register 2 (pointer address 1Ah) controls which temperature measurement channels are enabled and whether the external channels have the resistance correction feature enabled or not.

The RC bit enables the resistance correction feature for the external temperature channels. If RC = '1', series resistance correction is enabled; if RC = '0', resistance correction is disabled. Resistance correction should be enabled for most applications. However, disabling the resistance correction may yield slightly improved temperature measurement noise performance, and reduce conversion time by about 50%, which could lower power consumption when conversion rates of two per second or less are selected.

The LEN bit enables the local temperature measurement channel. If LEN = '1', the local channel is enabled; if LEN = '0', the local channel is disabled.

The REN bit enables external temperature measurement channel 1 (connected to pins 1 and 2.) If REN = '1', the external channel is enabled; if REN = '0', the external channel is disabled.

The temperature measurement sequence is local channel, external channel 1, shutdown, and delay (to set conversion rate, if necessary). The sequence starts over with the local channel. If any of the channels are disabled, they are skipped in the sequence. [Table 6](#) summarizes the bits of Configuration Register 2.

Table 6. Configuration Register 2 Bit Descriptions

| CONFIGURATION REGISTER 2 (Read/Write = 1A, POR = 1Ch) | | | |
|--|----------|---|----------------------|
| BIT | NAME | FUNCTION | POWER-ON RESET VALUE |
| 7, 6, 5 | Reserved | — | 0 |
| 4 | REN | 0 = External channel 1 disabled 1 = External channel 1 enabled | 1 |
| 3 | LEN | 0 = Local channel disabled 1 = Local channel enabled | 1 |
| 2 | RC | 0 = Resistance correction disabled 1 = Resistance correction enabled | 1 |
| 1, 0 | Reserved | — | 0 |

Conversion Rate Register

The Conversion Rate Register (pointer address 0Ah) controls the rate at which temperature conversions are performed. This register adjusts the idle time between conversions but not the conversion timing itself, thereby allowing the TMP435 power dissipation to be balanced with the temperature register update rate. [Table 7](#) shows the conversion rate options and corresponding current consumption.

Beta Compensation Configuration Register

If the Beta Compensation Configuration Register is set to '1xxx' (beta correction enabled) for a given channel at the beginning of each temperature conversion, the TMP435 automatically detects if the sensor is diode-connected or GND collector-connected, selects the proper beta range, and measures the sensor temperature appropriately.

If the Beta Compensation Configuration Register is set to '0111' (beta correction disabled) for a given channel, the automatic detection is bypassed and the temperature is measured assuming a diode-connected sensor. A PNP transistor may continue to be GND collector-connected in this mode, but no beta compensation factor is applied. When the beta correction is set to '0111' or the sensor is diode-connected (base shorted to collector), the n -factor used by the TMP435 is 1.008. When the beta correction configuration is set to '1xxx' (beta correction enabled) and the sensor is GND collector-connected (PNP collector to ground), the n -factor used by the TMP435 is 1.000. [Table 8](#) shows the read value for the selected beta ranges and the appropriate n -factor used for each conversion.

Table 7. Conversion Rate Register

| CONVERSION RATE REGISTER (Read = 04h, Write = 0Ah, POR = 07h) | | | | | | | | | | |
|---|----|----|----|----|----|----|----|----------------|--|-----------------------|
| R7 | R6 | R5 | R4 | R3 | R2 | R1 | R0 | CONVERSION/SEC | AVERAGE I _Q (TYP) (μ A) | |
| | | | | | | | | | V _S = 2.7V | V _S = 5.5V |
| 0 | 0 | 0 | 0 | 0 | 0 | 0 | 0 | 0.0625 | 11 | 32 |
| 0 | 0 | 0 | 0 | 0 | 0 | 0 | 1 | 0.125 | 17 | 38 |
| 0 | 0 | 0 | 0 | 0 | 0 | 1 | 0 | 0.25 | 28 | 49 |
| 0 | 0 | 0 | 0 | 0 | 0 | 1 | 1 | 0.5 | 47 | 69 |
| 0 | 0 | 0 | 0 | 0 | 1 | 0 | 0 | 1 | 80 | 103 |
| 0 | 0 | 0 | 0 | 0 | 1 | 0 | 1 | 2 | 128 | 155 |
| 0 | 0 | 0 | 0 | 0 | 1 | 1 | 0 | 4 | 190 | 220 |
| 07h to 0Fh | | | | | | | | 8 | 373 | 413 |

Table 8. Beta Compensation Configuration Register

| BCx3-BCx0 | BETA RANGE DESCRIPTION | n -FACTOR | TIME |
|-----------|---|-------------|-------|
| 1000 | Automatically selected range 0 (0.10 < beta < 0.18) | 1.000 | 126ms |
| 1001 | Automatically selected range 1 (0.16 < beta < 0.26) | 1.000 | 126ms |
| 1010 | Automatically selected range 2 (0.24 < beta < 0.43) | 1.000 | 126ms |
| 1011 | Automatically selected range 3 (0.35 < beta < 0.78) | 1.000 | 126ms |
| 1100 | Automatically selected range 4 (0.64 < beta < 1.8) | 1.000 | 126ms |
| 1101 | Automatically selected range 5 (1.4 < beta < 9.0) | 1.000 | 126ms |
| 1110 | Automatically selected range 6 (6.7 < beta < 40.0) | 1.000 | 126ms |
| 1111 | Automatically selected range 7 (beta > 27.0) | 1.000 | 126ms |
| 1111 | Automatically detected diode connected sensor | 1.008 | 93ms |
| 0000 | Manually selected range 0 (0.10 < beta < 0.5) | 1.000 | 93ms |
| 0001 | Manually selected range 1 (0.13 < beta < 1.0) | 1.000 | 93ms |
| 0010 | Manually selected range 2 (0.18 < beta < 2.0) | 1.000 | 93ms |
| 0011 | Manually selected range 3 (0.3 < beta < 25) | 1.000 | 93ms |
| 0100 | Manually selected range 4 (0.5 < beta < 50) | 1.000 | 93ms |
| 0101 | Manually selected range 5 (1.1 < beta < 100) | 1.000 | 93ms |
| 0110 | Manually selected range 6 (2.4 < beta < 150) | 1.000 | 93ms |
| 0111 | Manually disabled beta correction | 1.008 | 93ms |

n-Factor Correction Register

The TMP435 allows for a different *n*-factor value to be used for converting remote channel measurements to temperature. The remote channel uses sequential current excitation to extract a differential V_{BE} voltage measurement to determine the temperature of the remote transistor. Equation 1 relates this voltage and temperature.

$$V_{BE2} - V_{BE1} = \frac{nkT}{q} \ln\left(\frac{I_2}{I_1}\right) \tag{1}$$

The value *n* in Equation 1 is a characteristic of the particular transistor used for the remote channel. When the beta compensation configuration is set to '0111' (beta compensation disabled) or the sensor is diode-connected (base shorted to collector), the *n*-factor used by the TMP435 is 1.008. When the beta compensation configuration is set to '1000' (beta compensation enabled) and the sensor is GND collector-connected (PNP collector to ground), the *n*-factor used by the TMP435 is 1.000. If the *n*-factor used for the temperature conversion does not match the characteristic of the sensor, then temperature offset is observed. The value in the *n*-Factor Correction Register may be used to adjust the effective *n*-factor according to Equation 2 and Equation 3 for disabled beta compensation or a diode-connected sensor. Equation 4 and Equation 5 may be used for enabled beta compensation and a GND collector-connected sensor.

$$n_{eff} = \frac{1.008 \times 300}{300 - N_{ADJUST}} \tag{2}$$

$$N_{ADJUST} = 300 - \frac{300 \times 1.008}{n_{eff}} \tag{3}$$

$$n_{eff} = \frac{1.000 \times 300}{300 - N_{ADJUST}} \tag{4}$$

$$N_{ADJUST} = 300 - \frac{300 \times 1.000}{n_{eff}} \tag{5}$$

The *n*-correction value must be stored in twos-complement format, yielding an effective data

range from –128 to +127. Table 9 shows the *n*-factor range for both 1.008 and 1.000. For the TMP435, the *n*-correction value may be written to and read from pointer address 18h. The register power-on reset value is 00h, thus having no effect unless written to.

Table 9. *n*-Factor Range

| N _{ADJUST} | | | n-FACTOR |
|---------------------|-----|---------|----------|
| BINARY | HEX | DECIMAL | |
| 01111111 | 7F | 127 | 1.747977 |
| 00001010 | 0A | 10 | 1.042759 |
| 00001000 | 08 | 8 | 1.035616 |
| 00000110 | 06 | 6 | 1.028571 |
| 00000100 | 04 | 4 | 1.021622 |
| 00000010 | 02 | 2 | 1.014765 |
| 00000001 | 01 | 1 | 1.011371 |
| 00000000 | 00 | 0 | 1.008 |
| 11111111 | FF | –1 | 1.004651 |
| 11111110 | FE | –2 | 1.001325 |
| 11111100 | FC | –4 | 0.994737 |
| 11111010 | FA | –6 | 0.988235 |
| 11111000 | F8 | –8 | 0.981818 |
| 11110110 | F6 | –10 | 0.975484 |
| 10000000 | 80 | –128 | 0.706542 |

Software Reset

The TMP435 may be reset by writing any value to Pointer Register FCh. This action restores the power-on reset state to all of the TMP435 registers as well as abort any conversion in process and clear the ALERT and THERM pins.

The TMP435 also supports reset via the two-wire general call address (00000000). The TMP435 acknowledges the general call address and responds to the second byte. If the second byte is 00000110, the TMP435 executes a software reset. The TMP435 does not respond to other values in the second byte.

Consecutive Alert Register

The value in the Consecutive Alert Register (address 22h) determines how many consecutive out-of-limit measurements must occur on a measurement channel before the ALERT/THERM2 or the THERM signal is activated. The value in this register does not affect bits in the Status Register. Values of one, two, three, or four consecutive conversions can be selected; one conversion is the default. This function allows additional filtering for the ALERT/THERM2 or the THERM pin. Table 13 shows the consecutive alert bits. For bit descriptions, refer to Table 10.

Table 10. Consecutive Alert Register Bit Descriptions

| BIT NAME | | | NUMBER OF CONSECUTIVE OUT-OF-LIMIT MEASUREMENTS (ALERT/THERM) |
|------------|------------|------------|---|
| CALT2/CTH2 | CALT1/CTH1 | CALT0/CTH0 | |
| 0 | 0 | 0 | 1 |
| 0 | 0 | 1 | 2 |
| 0 | 1 | 1 | 3 |
| 1 | 1 | 1 | 4 |

Therm Hysteresis Register

The THERM Hysteresis Register, shown in Table 12, stores the hysteresis value used for the THERM pin alarm function and for the ALERT/THERM2 pin when the AL/TH is 1. This register must be programmed with a value that is less than the Local Temperature High Limit Register value, Remote Temperature High Limit Register value, Local THERM Limit Register value, or Remote THERM Limit Register value; otherwise, the respective temperature comparator

does not trip on the measured temperature falling edges. Allowable hysteresis values are shown in Table 11. The default hysteresis value is 10°C, whether the device is operating in the standard or extended mode setting.

Identification Registers

The TMP435 allows for the two-wire bus controller to query the device for manufacturer and device IDs to enable the device for software identification of the device at the particular two-wire bus address. The manufacturer ID is obtained by reading from pointer address FEh. The TMP435 returns 55h for the manufacturer code. The device ID is obtained by reading from pointer address FDh. The TMP435 returns 31h for the device ID (see Table 3). These registers are read-only.

Table 11. Allowable THERM Hysteresis Values

| TEMPERATURE (°C) | THERM HYSTERESIS VALUE | |
|------------------|---------------------------|-------|
| | TH[7:0] (STANDARD BINARY) | (HEX) |
| 0 | 0000 0000 | 00 |
| 1 | 0000 0001 | 01 |
| 5 | 0000 0101 | 05 |
| 10 | 0000 1010 | 0A |
| 25 | 0001 1001 | 19 |
| 50 | 0011 0010 | 32 |
| 75 | 0100 1011 | 4B |
| 100 | 0110 0100 | 64 |
| 125 | 0111 1101 | 7D |
| 127 | 0111 1111 | 7F |
| 150 | 1001 0110 | 96 |
| 175 | 1010 1111 | AF |
| 200 | 1100 1000 | C8 |
| 225 | 1110 0001 | E1 |
| 255 | 1111 1111 | FF |

Table 12. THERM Hysteresis Register Format

| THERM HYSTERESIS REGISTER (Read = 21h, Write = 21h, POR = 0Ah) | | | | | | | | |
|---|-----|-----|-----|-----|-----|-----|-----|-----|
| BIT # | D7 | D6 | D5 | D4 | D3 | D2 | D1 | D0 |
| BIT NAME | TH7 | TH6 | TH5 | TH4 | TH3 | TH2 | TH1 | TH0 |
| POR VALUE | 0 | 0 | 0 | 0 | 1 | 0 | 1 | 0 |

Table 13. Consecutive Alert Register Format

| CONSECUTIVE ALERT REGISTER (READ = 22h, WRITE = 22h, POR = 70h) | | | | | | | | |
|--|----|------|------|------|-------|-------|-------|----|
| BIT # | D7 | D6 | D5 | D4 | D3 | D2 | D1 | D0 |
| BIT NAME | 0 | CTH2 | CTH1 | CTH0 | CALT2 | CALT1 | CALT0 | 0 |
| POR VALUE | 0 | 1 | 1 | 1 | 0 | 0 | 0 | 0 |

Bus Overview

The TMP435 is SMBus interface-compatible. In SMBus protocol, the device that initiates the transfer is called a *master*, and the devices controlled by the master are *slaves*. The bus must be controlled by a master device that generates the serial clock (SCL), controls the bus access, and generates the START and STOP conditions.

To address a specific device, a START condition is initiated. START is indicated by pulling the data line (SDA) from a high to low logic level while SCL is high. All slaves on the bus shift in the slave address byte, with the last bit indicating whether a read or write operation is intended. During the ninth clock pulse, the slave being addressed responds to the master by generating an Acknowledge and pulling SDA low.

Data transfer is then initiated and sent over eight clock pulses followed by an Acknowledge bit. During data transfer SDA must remain stable while SCL is high, because any change in SDA while SCL is high is interpreted as a control signal.

Once all data have been transferred, the master generates a STOP condition. STOP is indicated by pulling SDA from low to high, while SCL is high.

Serial Interface

The TMP435 operates only as a slave device on either the two-wire bus or the SMBus. Connections to either bus are made via the open-drain I/O lines, SDA and SCL. The SDA and SCL pins feature integrated spike suppression filters and Schmitt triggers to minimize the effects of input spikes and bus noise. The TMP435 supports the transmission protocol for fast (1kHz to 400kHz) and high-speed (1kHz to 3.4MHz) modes. All data bytes are transmitted MSB first.

Serial Bus Address

To communicate with the TMP435, the master must first address slave devices via a slave address byte. The slave address byte consists of seven address bits, and a direction bit indicating the intent of executing a read or write operation.

The address of the TMP435 is 4Ch (1001100b).

Two-Wire Interface Slave Device Addresses

The TMP435 supports nine slave device addresses and is available in two different fixed serial interface addresses.

The A1 and A0 pins, as summarized in [Table 14](#)), set the slave device address for the TMP435.

Table 14. Two-Wire Addresses

| A0 | A1 | ADDRESS |
|----|----|----------|
| 0 | 0 | 1001 100 |
| 0 | 1 | 1001 101 |
| 1 | 0 | 1001 110 |
| 1 | 1 | 1001 111 |
| 0 | Z | 1001 000 |
| Z | 0 | 1001 001 |
| 1 | Z | 1001 010 |
| Z | 1 | 1001 011 |
| Z | Z | 0110 111 |

Read/Write Operations

Accessing a particular register on the TMP435 is accomplished by writing the appropriate value to the Pointer Register. The value for the Pointer Register is the first byte transferred after the slave address byte with the R/W bit low. Every write operation to the TMP435 requires a value for the Pointer Register (see [Figure 16](#)).

When reading from the TMP435, the last value stored in the Pointer Register by a write operation is used to determine which register is read by a read operation. To change the register pointer for a read operation, a new value must be written to the Pointer Register. This transaction is accomplished by issuing a slave address byte with the R/W bit low, followed by the Pointer Register byte. No additional data are required. The master can then generate a START condition and send the slave address byte with the R/W bit high to initiate the read command. See [Figure 17](#) for details of this sequence. If repeated reads from the same register are desired, it is not necessary to continually send the Pointer Register bytes, because the TMP435 retains the Pointer Register value until it is changed by the next write operation. Note that register bytes are sent MSB first, followed by the LSB.

TIMING DIAGRAMS

The TMP435 is two-wire and SMBus-compatible. Figure 15 to Figure 19 describe the various operations on the TMP435. Bus definitions are given below. Parameters for Figure 15 are defined in Table 15.

Bus Idle: Both SDA and SCL lines remain high.

Start Data Transfer: A change in the state of the SDA line, from high to low, while the SCL line is high, defines a START condition. Each data transfer is initiated with a START condition.

Stop Data Transfer: A change in the state of the SDA line from low to high while the SCL line is high defines a STOP condition. Each data transfer terminates with a STOP or a repeated START condition.

Data Transfer: The number of data bytes transferred between a START and a STOP condition is not limited and is determined by the master device. The receiver acknowledges the transfer of data.

Acknowledge: Each receiving device, when addressed, is obliged to generate an Acknowledge bit. A device that acknowledges must pull down the SDA line during the Acknowledge clock pulse in such a way that the SDA line is stable low during the high period of the Acknowledge clock pulse. Setup and hold times must be taken into account. On a master receive, data transfer termination can be signaled by the master generating a Not-Acknowledge on the last byte that has been transmitted by the slave.

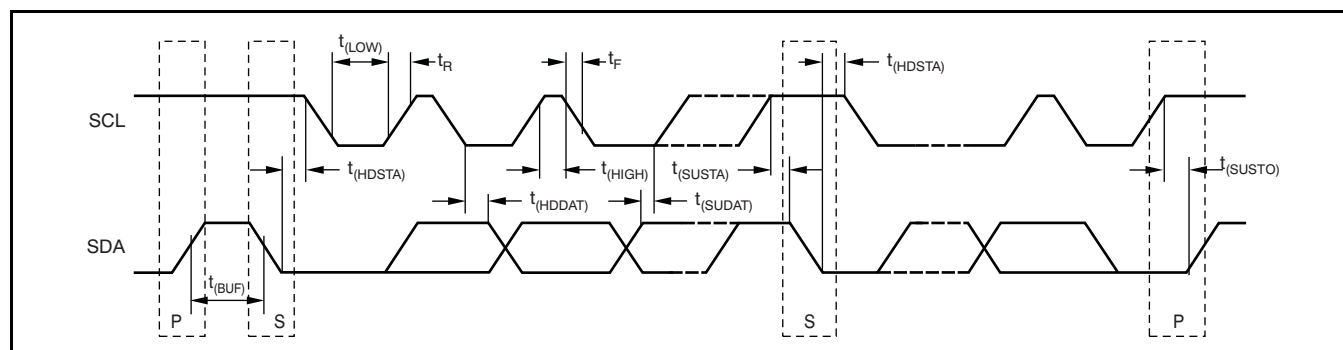

Figure 15. Two-Wire Timing Diagram

Table 15. Timing Diagram Definitions for Figure 15

| PARAMETER | | FAST MODE | | HIGH-SPEED MODE | | UNITS |
|--|---------------|------------------|------|------------------|-----|-------|
| | | MIN | MAX | MIN | MAX | |
| SCL Operating Frequency | $f_{(SCL)}$ | 0.001 | 0.4 | 0.001 | 3.4 | MHZ |
| Bus Free Time Between STOP and START Condition | $t_{(BUF)}$ | 600 | | 160 | | ns |
| Hold time after repeated START condition. After this period, the first clock is generated. | $t_{(HDSTA)}$ | 100 | | 100 | | ns |
| Repeated START Condition Setup Time | $t_{(SUSTA)}$ | 100 | | 100 | | ns |
| STOP Condition Setup Time | $t_{(SUSTO)}$ | 100 | | 100 | | ns |
| Data Hold Time | $t_{(HDDAT)}$ | 0 ⁽¹⁾ | | 0 ⁽²⁾ | | ns |
| Data Setup Time | $t_{(SUDAT)}$ | 100 | | 10 | | ns |
| SCL Clock LOW Period | $t_{(LOW)}$ | 1300 | | 160 | | ns |
| SCL Clock HIGH Period | $t_{(HIGH)}$ | 600 | | 60 | | ns |
| Clock/Data Fall Time | t_F | | 300 | | 160 | ns |
| Clock/Data Rise Time | t_R | | 300 | | 160 | ns |
| for SCLK ≤ 100kHz | | | 1000 | | | ns |

- (1) For cases with fall time of SCL less than 20ns and/or the rise time or fall time of SDA less than 20ns, the hold time should be greater than 20ns.
- (2) For cases with fall time of SCL less than 10ns and/or the rise or fall time of SDA less than 10ns, the hold time should be greater than 10ns.

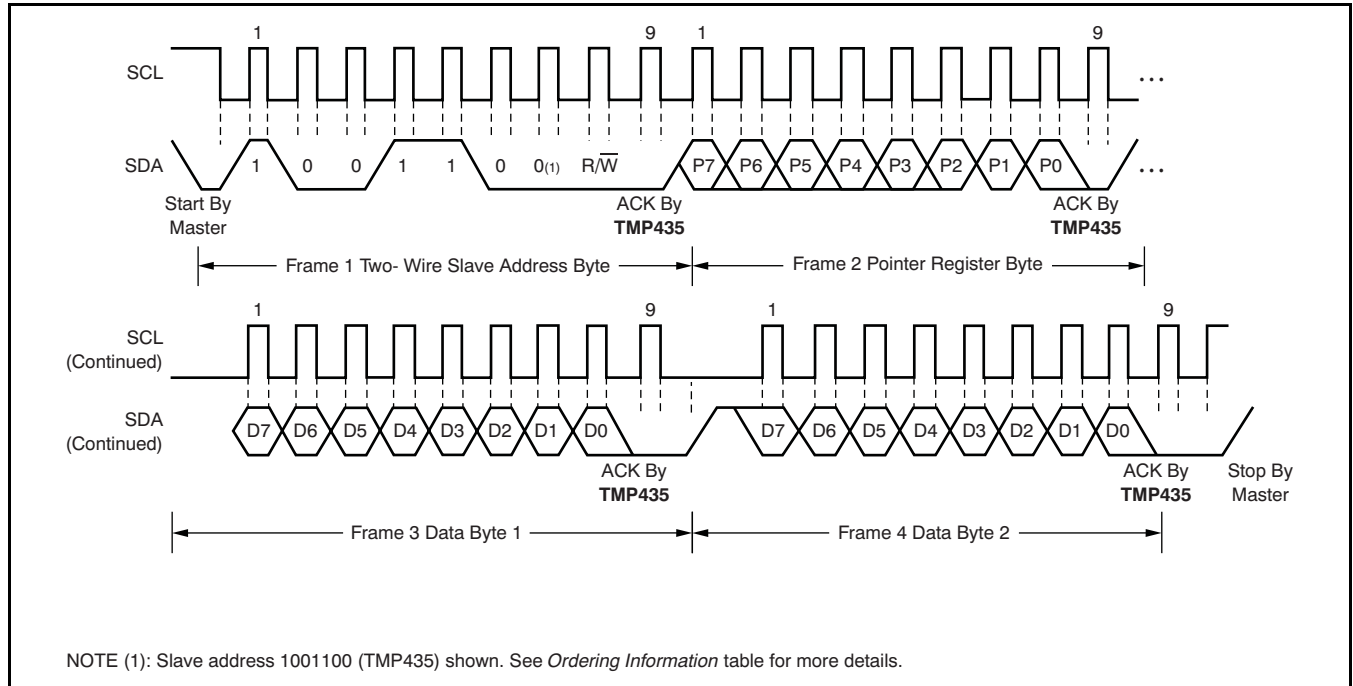

Figure 16. Two-Wire Timing Diagram for Write Word Format

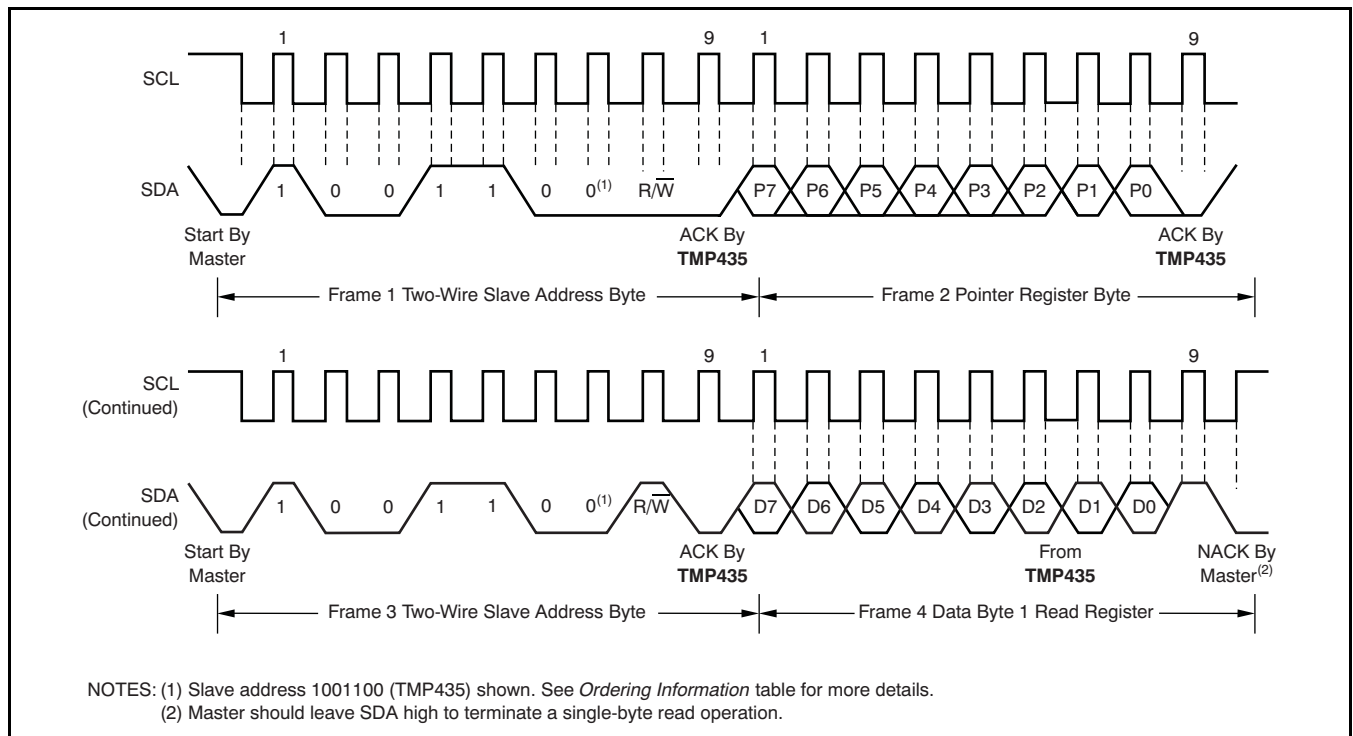

Figure 17. Two-Wire Timing Diagram for Single-Byte Read Format

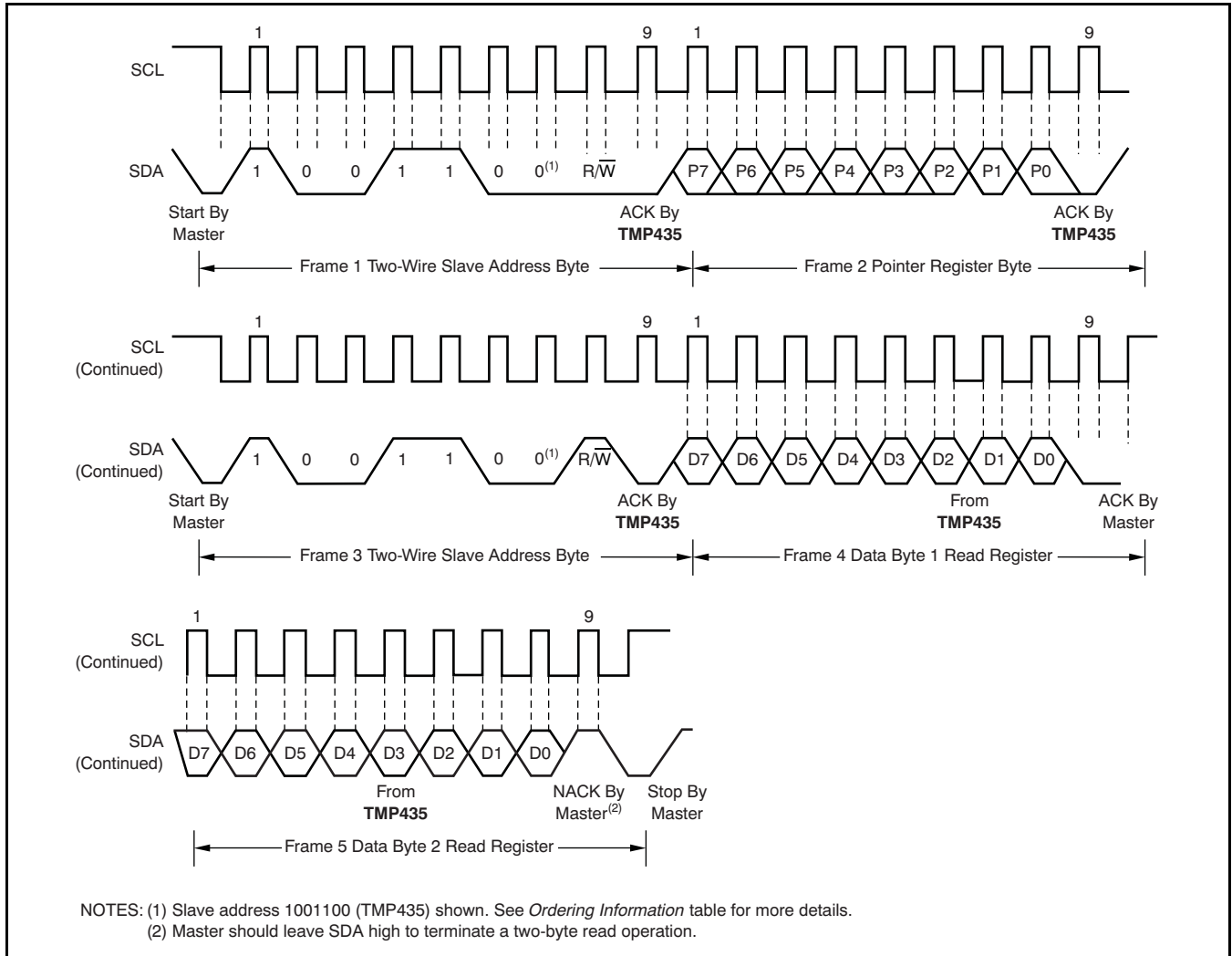

Figure 18. Two-Wire Timing Diagram for Two-Byte Read Format

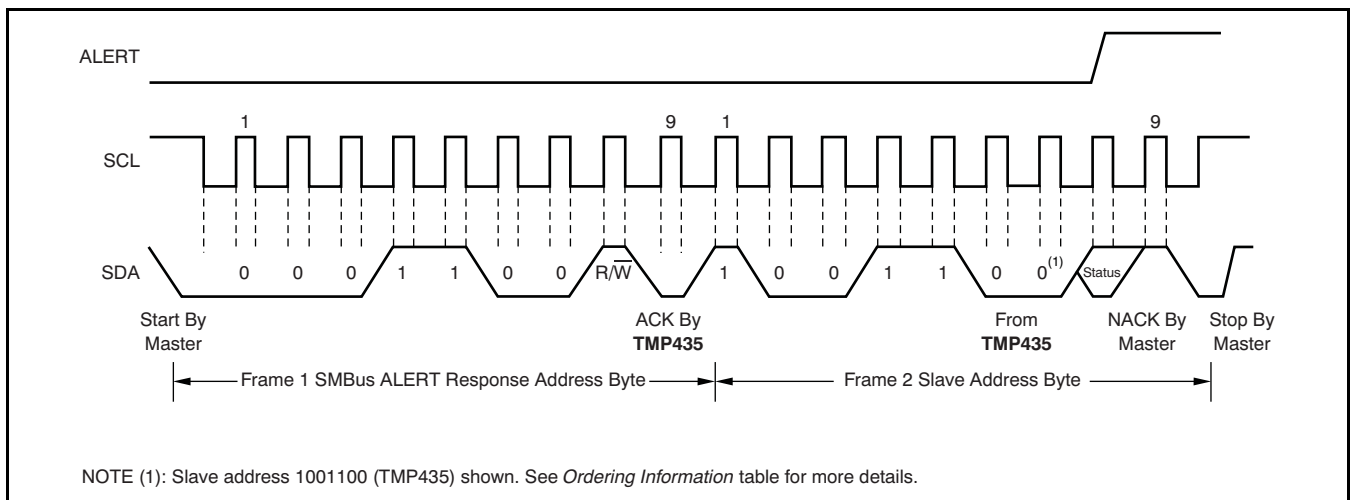

Figure 19. Timing Diagram for SMBus ALERT

High-Speed Mode

In order for the two-wire bus to operate at frequencies above 400kHz, the master device must issue a High-speed mode (Hs-mode) master code (00001XXX) as the first byte after a START condition to switch the bus to high-speed operation. The TMP435 does not acknowledge this byte, but switches the input filters on SDA and SCL and the output filter on SDA to operate in Hs-mode, allowing transfers at up to 3.4MHz. After the Hs-mode master code has been issued, the master transmits a two-wire slave address to initiate a data transfer operation. The bus continues to operate in Hs-mode until a STOP condition occurs on the bus. Upon receiving the STOP condition, the TMP435 switches the input and output filter back to fast-mode operation.

Timeout Function

The serial interface of the TMP435 resets if either SCL or SDA are held low for 32ms (typical) between a START and STOP condition. If the TMP435 is holding the bus low, it releases the bus and waits for a START condition.

$\overline{\text{THERM}}$ and $\overline{\text{ALERT/THERM2}}$

The TMP435 has two pins dedicated to alarm functions, the $\overline{\text{THERM}}$ and $\overline{\text{ALERT/THERM2}}$ pins. Both pins are open-drain outputs that each require a pull-up resistor to V+. These pins can be wire-ORed together with other alarm pins for system monitoring of multiple sensors. The $\overline{\text{THERM}}$ pin provides a thermal interrupt that cannot be software disabled. The $\overline{\text{ALERT}}$ pin is intended for use as an earlier warning interrupt, and can be software disabled, or masked. The $\overline{\text{ALERT/THERM2}}$ pin can also be configured for use as $\overline{\text{THERM2}}$, a second $\overline{\text{THERM}}$ pin (Configuration Register: AL/TH bit = 1). The default setting configures pin 6 for the TMP435 to function as $\overline{\text{ALERT}}$ (AL/TH = 0).

The $\overline{\text{THERM}}$ pin asserts low when either the measured local or remote temperature is outside of the temperature range programmed in the corresponding Local/Remote THERM Limit Register. The $\overline{\text{THERM}}$ temperature limit range can be programmed with a wider range than that of the limit registers, which allows $\overline{\text{ALERT}}$ to provide an earlier warning than $\overline{\text{THERM}}$. The $\overline{\text{THERM}}$ alarm resets automatically when the measured temperature returns to within the $\overline{\text{THERM}}$ temperature limit range

minus the hysteresis value stored in the THERM Hysteresis Register. The allowable values of hysteresis are shown in [Table 11](#). The default hysteresis is 10°C. When the $\overline{\text{ALERT/THERM2}}$ pin is configured as a second thermal alarm (Configuration Register: bit 7 = x, bit 5 = 1), it functions the same as $\overline{\text{THERM}}$, but uses the temperatures stored in the Local/Remote Temperature High Limit Registers to set its comparison range.

When $\overline{\text{ALERT/THERM2}}$ is configured as $\overline{\text{ALERT}}$ (Configuration Register: bit 7 = 0, bit 5 = 0), the pin asserts low when either the measured local or remote temperature violates the range limit set by the corresponding Local/Remote Temperature High/Low Limit Registers. This alert function can be configured to assert only if the range is violated a specified number of consecutive times (1, 2, 3, or 4). The consecutive violation limit is set in the Consecutive Alert Register. False alerts that occur as a result of environmental noise can be prevented by requiring consecutive faults. $\overline{\text{ALERT}}$ also asserts low if the remote temperature sensor is open-circuit. When the MASK function is enabled (Configuration Register 1: bit 7 = 1), $\overline{\text{ALERT}}$ is disabled (that is, masked). $\overline{\text{ALERT}}$ resets when the master reads the device address, as long as the condition that caused the alert no longer persists, and the Status Register has been reset.

SMBus Alert Function

The TMP435 supports the SMBus Alert function. When pin 6 is configured as an alert output, the $\overline{\text{ALERT}}$ pin of the TMP435 may be connected as an SMBus Alert signal. When a master detects an alert condition on the $\overline{\text{ALERT}}$ line, the master sends an SMBus Alert command (00011001) on the bus. If the $\overline{\text{ALERT}}$ pin of the TMP435 is active, the devices acknowledge the SMBus Alert command and respond by returning its slave address on the SDA line. The eighth bit (LSB) of the slave address byte indicates whether the temperature exceeding one of the temperature high limit settings or falling below one of the temperature low limit settings caused the alert condition. This bit is high if the temperature is greater than or equal to one of the temperature high limit settings; this bit is low if the temperature is less than one of the temperature low limit settings. See [Figure 20](#) for details of this sequence.

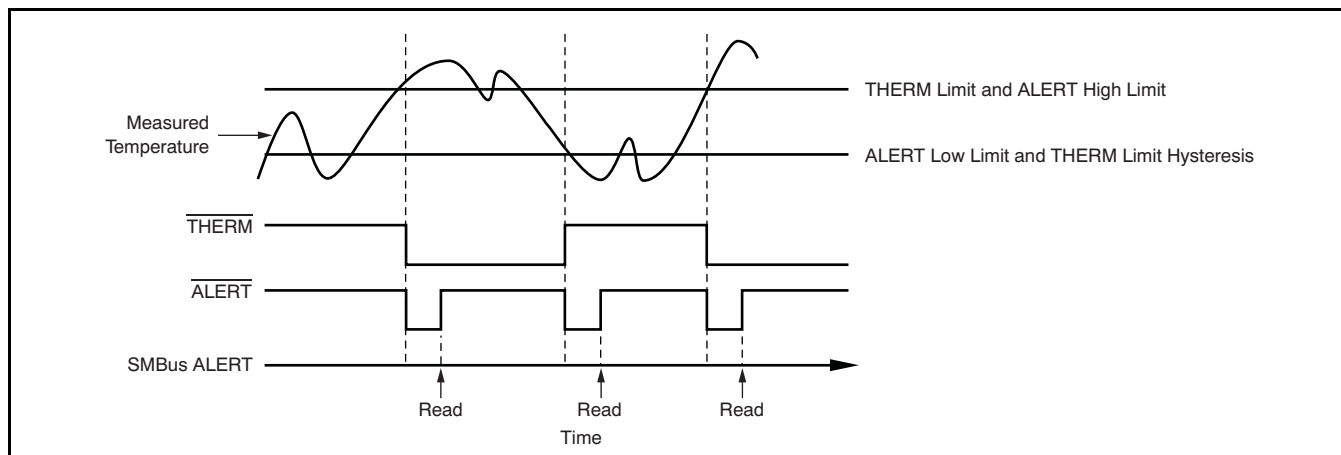

Figure 20. SMBus Alert Timing Diagram

If multiple devices on the bus respond to the SMBus Alert command, arbitration during the slave address portion of the SMBus Alert command determines which device must clear its $\overline{\text{alert}}$ status. If the TMP435 wins the arbitration, its $\overline{\text{ALERT}}$ pin becomes inactive at the completion of the SMBus Alert command. If the TMP435 loses the arbitration, the $\overline{\text{ALERT}}$ pin remains active.

Shutdown Mode (SD)

The TMP435 shutdown mode allows the user to save maximum power by shutting down all device circuitry other than the serial interface, reducing current consumption to typically less than 3 μ A; see the typical characteristic graph, *Shutdown Quiescent Current vs Supply Voltage* (Figure 6). Shutdown mode is enabled when the SD bit of the Configuration Register 1 is high; the device shuts down immediately, aborting the current conversion. When SD is low, the device maintains a continuous conversion state.

Sensor Fault

The TMP435 can sense a fault at the DXP input that results from incorrect diode connection or an open circuit. The detection circuitry consists of a voltage comparator that trips when the voltage at DXP exceeds $(V+) - 0.6V$ (typical). The comparator output is continuously checked during a conversion. If a fault is detected, the last valid measured temperature is used for the temperature measurement result, the OPEN bit (Status Register, bit 2) is set high, and, if the alert function is enabled, $\overline{\text{ALERT}}$ asserts low.

When not using the remote sensor with the TMP435, the DXP and DXN inputs must be connected together to prevent meaningless fault warnings.

Under-Voltage Lockout

The TMP435 senses when the power-supply voltage has reached a minimum voltage level for the ADC to function. The detection circuitry consists of a voltage comparator that enables the ADC after the power supply ($V+$) exceeds 2.45V (typical). The comparator output is continuously checked during a conversion. The TMP435 does not perform a temperature conversion if the power supply is not valid. The last valid measured temperature is used for the temperature measurement result.

General Call Reset

The TMP435 supports reset via the Two-Wire General Call address 00h (0000 0000b). The TMP435 acknowledges the General Call address and responds to the second byte. If the second byte is 06h (0000 0110b), the TMP435 executes a software reset. This software reset restores the power-on reset state to all TMP435 registers, aborts any conversion in progress, and clears the $\overline{\text{ALERT}}$ and $\overline{\text{THERM}}$ pins. The TMP435 takes no action in response to other values in the second byte.

Filtering

Remote junction temperature sensors are usually implemented in a noisy environment. Noise is frequently generated by fast digital signals and if not filtered properly will induce errors that can corrupt temperature measurements. The TMP435 has a built-in 65kHz filter on the inputs of DXP and DXN to minimize the effects of noise. However, a differential low-pass filter can help attenuate unwanted coupled signals. Exact component values are application-specific. It is also recommended that the capacitor value remains between 0pF to 2200pF with a series resistance less than 1k Ω .

Remote Sensing

The TMP435 is designed to be used with either discrete transistors or substrate transistors built into processor chips and ASICs. Either NPN- or PNP-type transistors can be used, as long as the base-emitter junction is used as the remote temperature sense. NPN transistors must be diode-connected. PNP transistors can either be transistor- or diode-connected (see [Figure 13](#)).

Errors in remote temperature sensor readings are typically the consequence of the ideality factor and current excitation used by the TMP435 versus the manufacturer-specified operating current for a given transistor. Some manufacturers specify a high-level and low-level current for the temperature-sensing substrate transistors. The TMP435 uses 6µA for I_{LOW} and 120µA for I_{HIGH}. The device allows for different *n*-factor values; see the [N-Factor Correction Register](#) section.

The ideality factor (*n*) is a measured characteristic of a remote temperature sensor diode as compared to an ideal diode. The ideality factor for the TMP435 is trimmed to be 1.008. For transistors whose ideality factor does not match the TMP435, [Equation 6](#) can be used to calculate the temperature error. Note that for the equation to be used correctly, actual temperature (°C) must be converted to Kelvin (K).

$$T_{ERR} = \left(\frac{n - 1.008}{1.008} \right) \times [273.15 + T(^{\circ}C)]$$

Where:

- *n* = Ideality factor of remote temperature sensor
- T(°C) = actual temperature
- T_{ERR} = Error in TMP435 reading because *n* ≠ 1.008
- Degree delta is the same for °C and K

For *n* = 1.004 and T(°C) = 100°C:

$$T_{ERR} = \left(\frac{1.004 - 1.008}{1.008} \right) \times (273.15 + 100^{\circ}C)$$

$$T_{ERR} = 1.48^{\circ}C \tag{7}$$

If a discrete transistor is used as the remote temperature sensor with the TMP435, the best accuracy can be achieved by selecting the transistor according to the following criteria:

1. Base-emitter voltage > 0.25V at 6µA, at the highest sensed temperature.
2. Base-emitter voltage < 0.95V at 120µA, at the lowest sensed temperature.

3. Base resistance < 100Ω.
4. Tight control of V_{BE} characteristics indicated by small variations in h_{FE} (that is, 50 to 150).

Based on these criteria, two recommended small-signal transistors are the 2N3904 (NPN) or 2N3906 (PNP).

Measurement Accuracy and Thermal Considerations

The temperature measurement accuracy of the TMP435 depends on the remote and/or local temperature sensor being at the same temperature as the system point being monitored. Clearly, if the temperature sensor is not in good thermal contact with the part of the system being monitored, then there is a delay in the response of the sensor to a temperature change in the system. For remote temperature sensing applications using a substrate transistor (or a small, SOT23 transistor) placed close to the device being monitored, this delay is usually not a concern.

The local temperature sensor inside the TMP435 monitors the ambient air around the device. The thermal time constant for the TMP435 is approximately two seconds. This constant implies that if the ambient air changes quickly by 100°C, it would take the TMP435 about 10 seconds (that is, five thermal time constants) to settle to within 1°C of the final value. In most applications, the TMP435 package is in thermal contact with the PCB, as well as subjected to forced airflow. The accuracy of the measured temperature directly depends on how accurately the PCB and forced airflow temperatures represent the temperature that the TMP435 is measuring. Additionally, the internal power dissipation of the TMP435 can cause the temperature to rise above the ambient or PCB temperature. The internal power dissipated as a result of exciting the remote temperature sensor is negligible because of the small currents used. For a 5.5V supply and maximum conversion rate of eight conversions per second, the TMP435 dissipates 1.82mW (PD_{IQ} = 5.5V × 330µA). If both the ALERT/THERM2 and THERM pins are each sinking 1mA, an additional power of 0.8mW is dissipated (PD_{OUT} = 1mA × 0.4V + 1mA × 0.4V = 0.8mW). Total power dissipation is then 2.62mW (PD_{IQ} + PD_{OUT}) and, with a θ_{JA} of 165°C/W, causes the junction temperature to rise approximately 0.432°C above the ambient.

Layout Considerations

Remote temperature sensing on the TMP435 measures very small voltages using very low currents; therefore, noise at the IC inputs must be minimized. Most applications using the TMP435 have high digital content, with several clocks and logic level transitions creating a noisy environment. Layout should adhere to the following guidelines:

1. Place the TMP435 as close to the remote junction sensor as possible.
2. Route the DXP and DXN traces next to each other and shield them from adjacent signals through the use of ground guard traces, as shown in [Figure 21](#). If a multilayer PCB is used, bury these traces between ground or V_{DD} planes to shield them from extrinsic noise sources. 5 mil (0,127 mm) PCB traces are recommended.
3. Minimize additional thermocouple junctions caused by copper-to-solder connections. If these junctions are used, make the same number and approximate locations of copper-to-solder connections in both the DXP and DXN connections to cancel any thermocouple effects.
4. Use a 0.1 μ F local bypass capacitor directly between the V+ and GND of the TMP435. [Figure 22](#) shows the suggested bypass capacitor placement for the TMP435. Minimize filter capacitance between DXP and DXN to 2200pF or less for optimum measurement performance. This capacitance includes any cable capacitance between the remote temperature sensor and TMP435.
5. If the connection between the remote temperature sensor and the TMP435 is less than 8 inches (20,32 cm), use a twisted-wire pair connection. Beyond 8 inches, use a twisted, shielded pair with the shield grounded as close to the TMP435 as possible. Leave the remote sensor connection end of the shield wire open to avoid ground loops and 60Hz pickup.
6. Thoroughly clean and remove all flux residue in and around the pins of the TMP435 to avoid

temperature offset readings as a result of leakage paths between DXP or DXN and GND, or between DXP or DXN and V+.

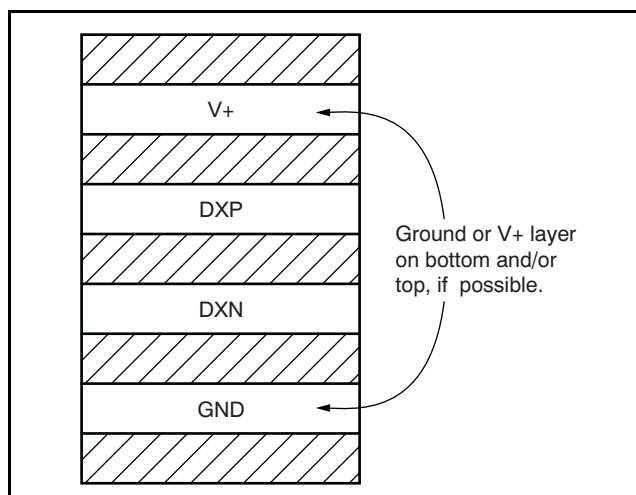

Note: Use 5mil (.005in, or 0,127mm) traces with 5mil spacing.

Figure 21. Example Signal Traces

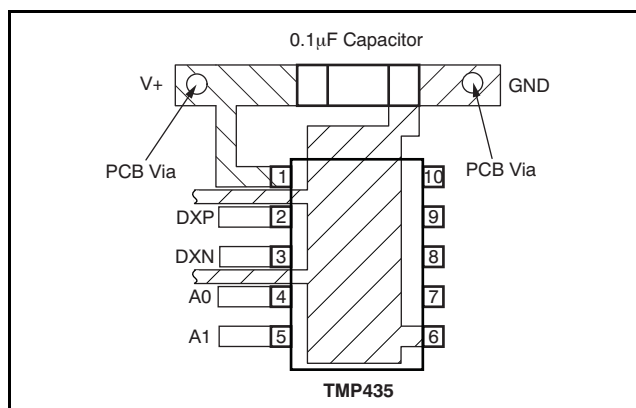

Figure 22. Suggested Bypass Capacitor Placement

REVISION HISTORY

NOTE: Page numbers for previous revisions may differ from page numbers in the current version.

| Changes from Original (March, 2010) to Revision A | Page |
|--|-------------|
| • Changed typo in second paragraph of Beta Compensation Configuration Register section to clarify state of beta correction | 17 |
| • Corrected POR value in Table 7 | 17 |
| • Corrected Equation 7 | 26 |

PACKAGING INFORMATION

| Orderable Device | Status (1) | Package Type | Package Drawing | Pins | Package Qty | Eco Plan (2) | Lead/Ball Finish (6) | MSL Peak Temp (3) | Op Temp (°C) | Device Marking (4/5) | Samples |
|------------------|---------------|--------------|-----------------|------|-------------|-------------------------|----------------------------|----------------------|--------------|-------------------------|-------------------------|
| TMP435ADGSR | ACTIVE | VSSOP | DGS | 10 | 2500 | Green (RoHS & no Sb/Br) | CU NIPDAU CU NIPDAUAG | Level-2-260C-1 YEAR | -40 to 125 | DTP1 | Samples |
| TMP435ADGST | ACTIVE | VSSOP | DGS | 10 | 250 | Green (RoHS & no Sb/Br) | CU NIPDAU CU NIPDAUAG | Level-2-260C-1 YEAR | -40 to 125 | DTP1 | Samples |

(1) The marketing status values are defined as follows:

ACTIVE: Product device recommended for new designs.

LIFEBUY: TI has announced that the device will be discontinued, and a lifetime-buy period is in effect.

NRND: Not recommended for new designs. Device is in production to support existing customers, but TI does not recommend using this part in a new design.

PREVIEW: Device has been announced but is not in production. Samples may or may not be available.

OBSELETE: TI has discontinued the production of the device.

(2) Eco Plan - The planned eco-friendly classification: Pb-Free (RoHS), Pb-Free (RoHS Exempt), or Green (RoHS & no Sb/Br) - please check <http://www.ti.com/productcontent> for the latest availability information and additional product content details.

TBD: The Pb-Free/Green conversion plan has not been defined.

Pb-Free (RoHS): TI's terms "Lead-Free" or "Pb-Free" mean semiconductor products that are compatible with the current RoHS requirements for all 6 substances, including the requirement that lead not exceed 0.1% by weight in homogeneous materials. Where designed to be soldered at high temperatures, TI Pb-Free products are suitable for use in specified lead-free processes.

Pb-Free (RoHS Exempt): This component has a RoHS exemption for either 1) lead-based flip-chip solder bumps used between the die and package, or 2) lead-based die adhesive used between the die and leadframe. The component is otherwise considered Pb-Free (RoHS compatible) as defined above.

Green (RoHS & no Sb/Br): TI defines "Green" to mean Pb-Free (RoHS compatible), and free of Bromine (Br) and Antimony (Sb) based flame retardants (Br or Sb do not exceed 0.1% by weight in homogeneous material)

(3) MSL, Peak Temp. - The Moisture Sensitivity Level rating according to the JEDEC industry standard classifications, and peak solder temperature.

(4) There may be additional marking, which relates to the logo, the lot trace code information, or the environmental category on the device.

(5) Multiple Device Markings will be inside parentheses. Only one Device Marking contained in parentheses and separated by a "~" will appear on a device. If a line is indented then it is a continuation of the previous line and the two combined represent the entire Device Marking for that device.

(6) Lead/Ball Finish - Orderable Devices may have multiple material finish options. Finish options are separated by a vertical ruled line. Lead/Ball Finish values may wrap to two lines if the finish value exceeds the maximum column width.

Important Information and Disclaimer:The information provided on this page represents TI's knowledge and belief as of the date that it is provided. TI bases its knowledge and belief on information provided by third parties, and makes no representation or warranty as to the accuracy of such information. Efforts are underway to better integrate information from third parties. TI has taken and continues to take reasonable steps to provide representative and accurate information but may not have conducted destructive testing or chemical analysis on incoming materials and chemicals. TI and TI suppliers consider certain information to be proprietary, and thus CAS numbers and other limited information may not be available for release.

In no event shall TI's liability arising out of such information exceed the total purchase price of the TI part(s) at issue in this document sold by TI to Customer on an annual basis.

TAPE AND REEL INFORMATION

QUADRANT ASSIGNMENTS FOR PIN 1 ORIENTATION IN TAPE

*All dimensions are nominal

| Device | Package Type | Package Drawing | Pins | SPQ | Reel Diameter (mm) | Reel Width W1 (mm) | A0 (mm) | B0 (mm) | K0 (mm) | P1 (mm) | W (mm) | Pin1 Quadrant |
|-------------|--------------|-----------------|------|------|--------------------|--------------------|---------|---------|---------|---------|--------|---------------|
| TMP435ADGSR | VSSOP | DGS | 10 | 2500 | 330.0 | 12.4 | 5.3 | 3.4 | 1.4 | 8.0 | 12.0 | Q1 |
| TMP435ADGSR | VSSOP | DGS | 10 | 2500 | 330.0 | 12.4 | 5.3 | 3.4 | 1.4 | 8.0 | 12.0 | Q1 |
| TMP435ADGST | VSSOP | DGS | 10 | 250 | 177.8 | 12.4 | 5.3 | 3.4 | 1.4 | 8.0 | 12.0 | Q1 |
| TMP435ADGST | VSSOP | DGS | 10 | 250 | 330.0 | 12.4 | 5.3 | 3.4 | 1.4 | 8.0 | 12.0 | Q1 |

TAPE AND REEL BOX DIMENSIONS

*All dimensions are nominal

| Device | Package Type | Package Drawing | Pins | SPQ | Length (mm) | Width (mm) | Height (mm) |
|-------------|--------------|-----------------|------|------|-------------|------------|-------------|
| TMP435ADGSR | VSSOP | DGS | 10 | 2500 | 346.0 | 346.0 | 41.0 |
| TMP435ADGSR | VSSOP | DGS | 10 | 2500 | 366.0 | 364.0 | 50.0 |
| TMP435ADGST | VSSOP | DGS | 10 | 250 | 202.0 | 201.0 | 28.0 |
| TMP435ADGST | VSSOP | DGS | 10 | 250 | 366.0 | 364.0 | 50.0 |

DGS0010A



PACKAGE OUTLINE

VSSOP - 1.1 mm max height

SMALL OUTLINE PACKAGE

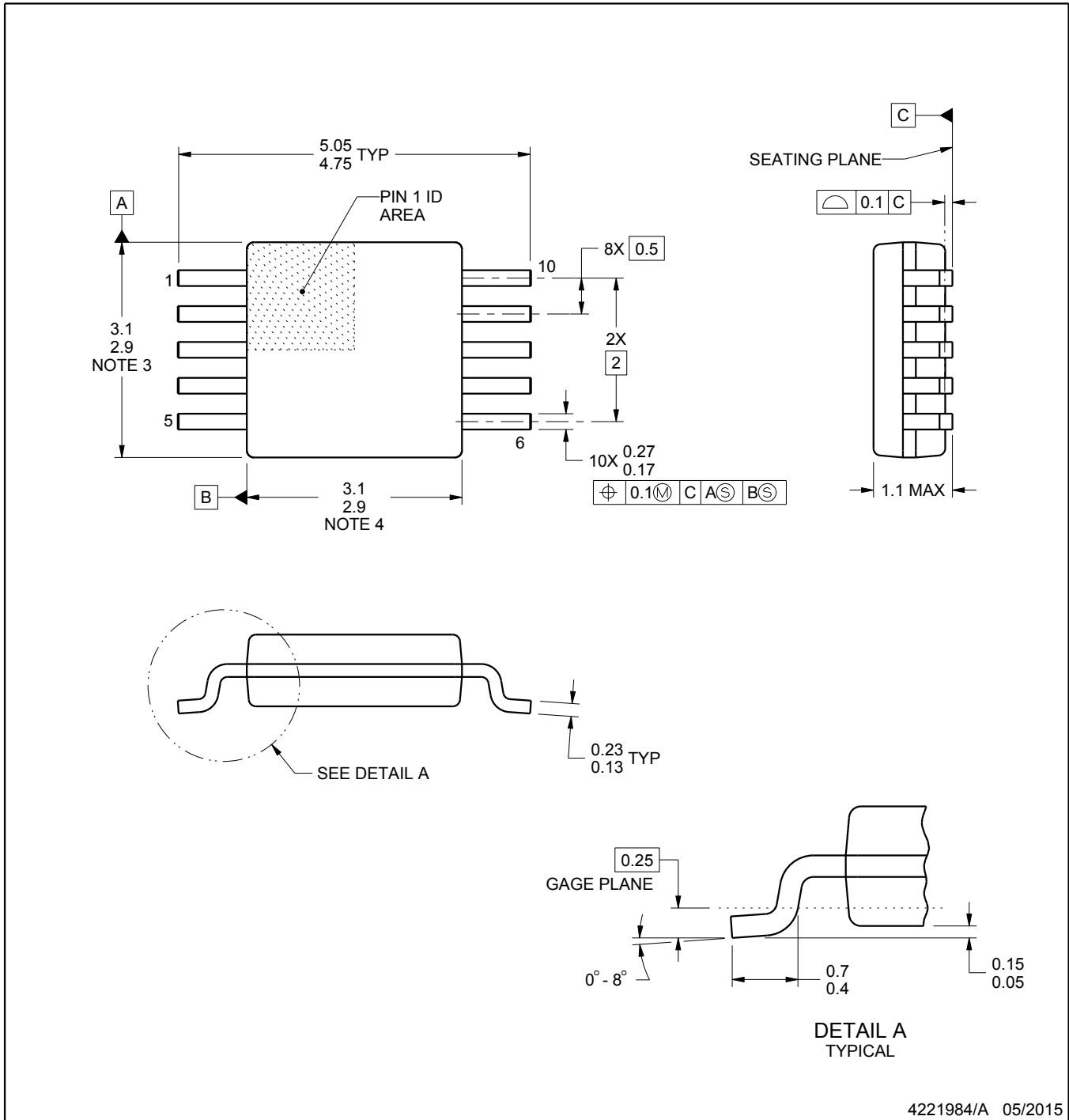

4221984/A 05/2015

NOTES:

1. All linear dimensions are in millimeters. Any dimensions in parenthesis are for reference only. Dimensioning and tolerancing per ASME Y14.5M.
2. This drawing is subject to change without notice.
3. This dimension does not include mold flash, protrusions, or gate burrs. Mold flash, protrusions, or gate burrs shall not exceed 0.15 mm per side.
4. This dimension does not include interlead flash. Interlead flash shall not exceed 0.25 mm per side.
5. Reference JEDEC registration MO-187, variation BA.

EXAMPLE BOARD LAYOUT

DGS0010A

VSSOP - 1.1 mm max height

SMALL OUTLINE PACKAGE



LAND PATTERN EXAMPLE
SCALE:10X

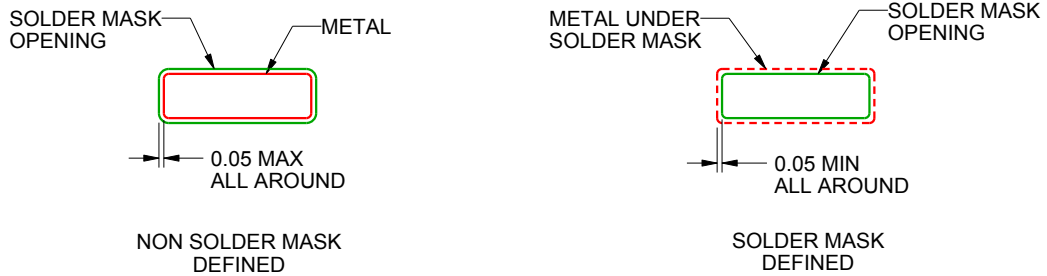

SOLDER MASK DETAILS
NOT TO SCALE

4221984/A 05/2015

NOTES: (continued)

- 6. Publication IPC-7351 may have alternate designs.
- 7. Solder mask tolerances between and around signal pads can vary based on board fabrication site.

EXAMPLE STENCIL DESIGN

DGS0010A

VSSOP - 1.1 mm max height

SMALL OUTLINE PACKAGE



SOLDER PASTE EXAMPLE
BASED ON 0.125 mm THICK STENCIL
SCALE:10X

4221984/A 05/2015

NOTES: (continued)

8. Laser cutting apertures with trapezoidal walls and rounded corners may offer better paste release. IPC-7525 may have alternate design recommendations.
9. Board assembly site may have different recommendations for stencil design.

IMPORTANT NOTICE AND DISCLAIMER

TI PROVIDES TECHNICAL AND RELIABILITY DATA (INCLUDING DATASHEETS), DESIGN RESOURCES (INCLUDING REFERENCE DESIGNS), APPLICATION OR OTHER DESIGN ADVICE, WEB TOOLS, SAFETY INFORMATION, AND OTHER RESOURCES "AS IS" AND WITH ALL FAULTS, AND DISCLAIMS ALL WARRANTIES, EXPRESS AND IMPLIED, INCLUDING WITHOUT LIMITATION ANY IMPLIED WARRANTIES OF MERCHANTABILITY, FITNESS FOR A PARTICULAR PURPOSE OR NON-INFRINGEMENT OF THIRD PARTY INTELLECTUAL PROPERTY RIGHTS.

These resources are intended for skilled developers designing with TI products. You are solely responsible for (1) selecting the appropriate TI products for your application, (2) designing, validating and testing your application, and (3) ensuring your application meets applicable standards, and any other safety, security, or other requirements. These resources are subject to change without notice. TI grants you permission to use these resources only for development of an application that uses the TI products described in the resource. Other reproduction and display of these resources is prohibited. No license is granted to any other TI intellectual property right or to any third party intellectual property right. TI disclaims responsibility for, and you will fully indemnify TI and its representatives against, any claims, damages, costs, losses, and liabilities arising out of your use of these resources.

TI's products are provided subject to TI's Terms of Sale (www.ti.com/legal/termsofsale.html) or other applicable terms available either on ti.com or provided in conjunction with such TI products. TI's provision of these resources does not expand or otherwise alter TI's applicable warranties or warranty disclaimers for TI products.

Mailing Address: Texas Instruments, Post Office Box 655303, Dallas, Texas 75265
Copyright © 2019, Texas Instruments Incorporated

Looking for pricing, stock, or lifecycle information?

Click below to explore more details on WIN SOURCE:

 [View TMP435ADGST](#) on WIN SOURCE

 [Texas Instruments](#) Information

Optimize Your Supply Chain with WIN SOURCE Solutions

-  Global Sourcing Solution
-  Obsolete Management
-  Cost Control Management
-  Shortage Management
-  Alternative Solution
-  Excess Inventory Management