



**THE DATASHEET OF
BCM43236BKMLGT**





The following document contains information on Cypress products. Although the document is marked with the name “Broadcom”, the company that originally developed the specification, Cypress will continue to offer these products to new and existing customers.

CONTINUITY OF SPECIFICATIONS

There is no change to this document as a result of offering the device as a Cypress product. Any changes that have been made are the result of normal document improvements and are noted in the document history page, where supported. Future revisions will occur when appropriate, and changes will be noted in a document history page.

CONTINUITY OF ORDERING PART NUMBERS

Cypress continues to support existing part numbers. To order these products, please use only the Ordering Part Numbers listed in this document.

FOR MORE INFORMATION

Please visit our website at www.cypress.com or contact your [local sales office](#) for additional information about Cypress products and services.

OUR CUSTOMERS

Cypress is for true innovators – in companies both large and small.

Our customers are smart, aggressive, out-of-the-box thinkers who design and develop game-changing products that revolutionize their industries or create new industries with products and solutions that nobody ever thought of before.

ABOUT CYPRESS

Founded in 1982, Cypress is the leader in advanced embedded system solutions for the world's most innovative automotive, industrial, home automation and appliances, consumer electronics and medical products. Cypress's programmable systems-on-chip, general-purpose microcontrollers, analog ICs, wireless and USB-based connectivity solutions and reliable, high-performance memories help engineers design differentiated products and get them to market first.

Cypress is committed to providing customers with the best support and engineering resources on the planet enabling innovators and out-of-the-box thinkers to disrupt markets and create new product categories in record time. To learn more, go to www.cypress.com.

Not Recommended for New Designs



BCM43236/BCM43236B

2.4 GHz/5 GHz IEEE802.11n MAC/PHY/Radio Chip

GENERAL DESCRIPTION

The BCM43236/BCM43236B is a dual-band (2.4 GHz and 5 GHz) IEEE 802.11n-compliant MAC/PHY/Radio complete system-on-a-chip with 2.4 GHz and 5 GHz internal PAs. The device enables development of USB 2.0- or HSIC-based IEEE 802.11n WLAN client and router subsystem solutions. The BCM43236/BCM43236B addresses all WLAN markets that deliver high throughput and extended range of the Broadcom second-generation MIMO solution. With MIMO, information is bidirectional over two or more antennas simultaneously using the same frequency band thus providing greater range and increasing throughput, while maintaining compatibility with legacy IEEE 802.11a/b/g devices. This is accomplished by a combination of enhanced MAC and PHY implementations including spatial transmitter/receiver multiplexing modes and advanced DSP techniques to improve receive sensitivity.

43236B Enhancements:

256 KB ROM with WLAN driver mapped to support CPU host offload for low-end SoC platforms. Improved radio for better band edge and output power performance. Open Source Linux driver support.

The BCM43236/BCM43236B architecture with its fully integrated dual-band radio transceiver supports 2 × 2 antennas for Layer 2 throughput of over 200 Mbps. State-of-the-art security is provided by industry standardized system support for WPA™, WPA2™ (IEEE 802.11i), and hardware-accelerated AES encryption/decryption, coupled with TKIP and IEEE 802.1X support. Embedded hardware acceleration enables increased performance and significant reduction in host-CPU utilization in both client and access point configurations. The BCM43236/BCM43236B also supports Broadcom's widely accepted and deployed WPS for ease-of-use wireless secured networks.

FEATURES

- IEEE 802.11n-compliant
- 2.4 GHz and 5 GHz internal PA
- Two-stream spatial multiplexing up to 300 Mbps
- Uses on-chip OTP (One-Time Programmable) memory instead of SRAM for substantial RBOM savings.
- Supports MCS 0–15 and MCS 32 modulation and coding rates.
- Supports 20 MHz and 40 MHz channels with optional SGI.
- Support for STBC in both TX and RX
- Greenfield, mixed mode, and legacy modes supported
- Full IEEE 802.11a/b/g legacy compatibility with enhanced performance.
- Supports one USB 2.0 host or one 480 MHz HSIC port.
- UART and JTAG interface, up to eight GPIOs.
- Supports up to 32 MB of serial flash memory.
- ARM® Cortex-M3™ CPU core plus 256 KB ROM and 448 KB RAM.
- 256 KB ROM supports driver ROMLIB of the latest driver for CPU host offload functionality.
- Supports Broadcom's OneDriver™ software.
- Supports WHQL certified drivers for Windows® Vista 32- and 64-bit, Windows® XP, and Windows 2000 operating systems for client applications.
- Supports Linux® and VxWorks® for access point and router applications.
- Comprehensive wireless network security support that includes WPA, WPA2, and AES encryption/decryption coupled with TKIP and IEEE 802.1X support.
- BCM43236/BCM43236B package: 10 mm x 10 mm 88-pin QFN

APPLICATIONS

- USB 2.0 dongles
- HSIC media modules

Not Recommended for New Designs

Figure 1: BCM43236/BCM43236B Block Diagram

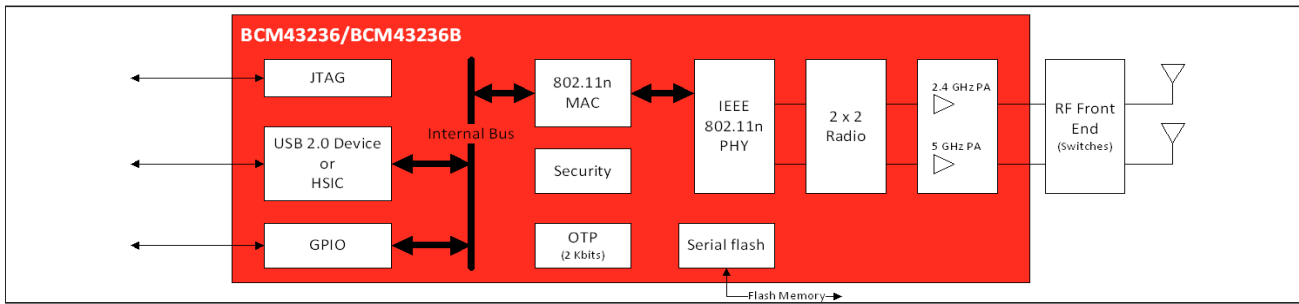

Broadcom Corporation
 5300 California Avenue
 Irvine, CA 92617

© 2013 by Broadcom Corporation
 All rights reserved
 Printed in the U.S.A.

Broadcom®, the pulse logo, Connecting everything®, and the Connecting everything logo are among the trademarks of Broadcom Corporation and/or its affiliates in the United States, certain other countries and/or the EU. Any other trademarks or trade names mentioned are the property of their respective owners.

This data sheet (including, without limitation, the Broadcom component(s) identified herein) is not designed, intended, or certified for use in any military, nuclear, medical, mass transportation, aviation, navigations, pollution control, hazardous substances management, or other high-risk application. BROADCOM PROVIDES THIS DATA SHEET "AS-IS," WITHOUT WARRANTY OF ANY KIND. BROADCOM DISCLAIMS ALL WARRANTIES, EXPRESSED AND IMPLIED, INCLUDING, WITHOUT LIMITATION, THE IMPLIED WARRANTIES OF MERCHANTABILITY, FITNESS FOR A PARTICULAR PURPOSE, AND NON-INFRINGEMENT.

Not Recommended for New Designs

Revision History

Revision	Date	Change Description
002-14912 Rev *D	09/19/16	Parts in this Datasheet are not recommended for new designs.
43236_43236B-DS103-R	09/16/13	Updated: <ul style="list-style-type: none">• Table 3: “Signal Descriptions,” on page 22.
43236_43236B-DS102-R	03/06/12	Added: <ul style="list-style-type: none">• Figure 11: “Power Supply Sequence,” on page 37.
43236_43236B-DS101-R	10/14/11	Updated: <ul style="list-style-type: none">• Table 5: “Absolute Maximum Ratings,” on page 26.
43236_43236B-DS100-R	6/24/11	Initial release

Not Recommended for New Designs

Table of Contents

About This Document	8
Purpose and Audience	8
Acronyms and Abbreviations	8
Technical Support	8
Section 1: Introduction	9
Section 2: Functional Description	11
Global Functions	11
Power Management	11
Voltage Regulators.....	11
Reset	11
GPIO Interface.....	11
Bluetooth Coexistence Interface	12
OTP.....	12
JTAG Interface.....	12
UART Interface.....	12
Serial Flash Interface.....	12
USB/HSIC Interface	13
Crystal Oscillator	14
IEEE 802.11n MAC Description	15
IEEE 802.11n PHY Description	17
Dual-Band Radio Transceiver	19
Receiver Path	19
Transmitter Path	19
Calibration.....	19
Section 3: Pin Assignments	20
BCM43236/BCM43236B 88-Pin QFN Assignments	20
Signals by Pin Number	21
Section 4: Signal and Pin Descriptions	22
Package Signal Descriptions	22
Strapping Options	26
Section 5: Electrical Characteristics	27
Absolute Maximum Ratings	27
Recommended Operating Conditions and DC Characteristics	28

Not Recommended for New Designs

Current Consumption from the 3.3V Supply28

Current Consumption from the 1.2V Supply28

HSIC Characteristics29

Section 6: RF Specifications 30

 2.4 GHz Band General RF Specifications30

 2.4 GHz Band Receiver RF Specifications31

 2.4 GHz Band Transmitter RF Specifications32

 2.4 GHz Band Local Oscillator Specifications32

 5 GHz Band Receiver RF Specifications33

 5 GHz Band Transmitter RF Specifications34

 5 GHz Band Local Oscillator Frequency Generator Specifications34

 On-Chip Regulator Power Supply Characteristics35

Section 7: Timing Characteristics 36

 Reset and Clock Timing Diagram36

 Serial Flash Timing Diagram37

Section 8: Thermal Information 39

 Junction Temperature Estimation and PSI_{JT} Versus Θ_{JC} 39

Section 9: Package Information 40

Section 10: Ordering Information 41

Not Recommended for New Designs

List of Figures

Figure 1: BCM43236/BCM43236B Block Diagram.....	2
Figure 2: MIMO System Diagram Showing 2 × 2 Antenna Configuration	9
Figure 3: Functional Block Diagram.....	10
Figure 4: USB 2.0 Device/HSIC Core Block Diagram	13
Figure 5: Recommended Oscillator Configuration	15
Figure 6: Enhanced MAC Block Diagram	16
Figure 7: PHY Block Diagram	18
Figure 8: BCM43236/BCM43236B 88-Pin QFN Package	20
Figure 9: Timing for the Optional External Power-On Reset.....	36
Figure 10: Serial Flash Timing Diagram (STMicroelectronics-Compatible).....	37
Figure 11: Power Supply Sequence	38
Figure 12: BCM43236/BCM43236B Mechanical Drawing.....	40

Not Recommended for New Designs

List of Tables

Table 1: Crystal Oscillator Requirements	14
Table 2: Pin Assignments.....	21
Table 3: Signal Descriptions.....	22
Table 4: Strapping Options	26
Table 5: Absolute Maximum Ratings.....	27
Table 6: Recommended Operating Conditions and DC Characteristics	28
Table 7: Current Consumption from 3.3V Supply.....	28
Table 8: Current Consumption from 1.2V Supply.....	28
Table 9: HSIC Characteristics	29
Table 10: 2.4 GHz Band General RF Specifications.....	30
Table 11: 2.4 GHz Band Receiver RF Specifications.....	31
Table 12: 2.4 GHz Band Transmitter RF Specifications.....	32
Table 13: 2.4 GHz Band Local Oscillator Specifications	32
Table 14: 5 GHz Band Receiver RF Specifications.....	33
Table 15: 5 GHz Band Transmitter RF Specifications.....	34
Table 16: 5 GHz Band Local Oscillator Frequency Generator Specifications.....	34
Table 17: On-Chip Regulator Power Supply Characteristics.....	35
Table 18: Ext_por and Clock Timing	36
Table 19: Serial Flash Timing	37
Table 20: 88-Pin QFN Thermal Characteristics	39
Table 21: Ordering Information.....	41

Not Recommended for New Designs

About This Document

Purpose and Audience

This document provides details of the functional, operational, and electrical characteristics of the Broadcom® BCM43236/BCM43236B. It is intended for hardware design, application, and OEM engineers.

Acronyms and Abbreviations

In most cases, acronyms and abbreviations are defined on first use.

For a comprehensive list of acronyms and other terms used in Broadcom documents, go to:
<http://www.broadcom.com/press/glossary.php>.

Technical Support

Broadcom provides customer access to a wide range of information, including technical documentation, schematic diagrams, product bill of materials, PCB layout information, and software updates through its customer support portal (<https://support.broadcom.com>). For a CSP account, contact your Sales or Engineering support representative.

In addition, Broadcom provides other product support through its Downloads & Support site (<http://www.broadcom.com/support/>).

Section 1: Introduction

The BCM43236/BCM43236B chips are the latest innovative chips from Broadcom® based on IEEE 802.11n. These chips are designed to take current WLAN systems to the next level of higher performance and greater range with Multiple Input Multiple Output (MIMO) technology, as shown in Figure 2. The IEEE 802.11n standard more than doubles the spectral efficiency compared to that of current IEEE 802.11a/g WLANs.

Figure 2: MIMO System Diagram Showing 2 × 2 Antenna Configuration

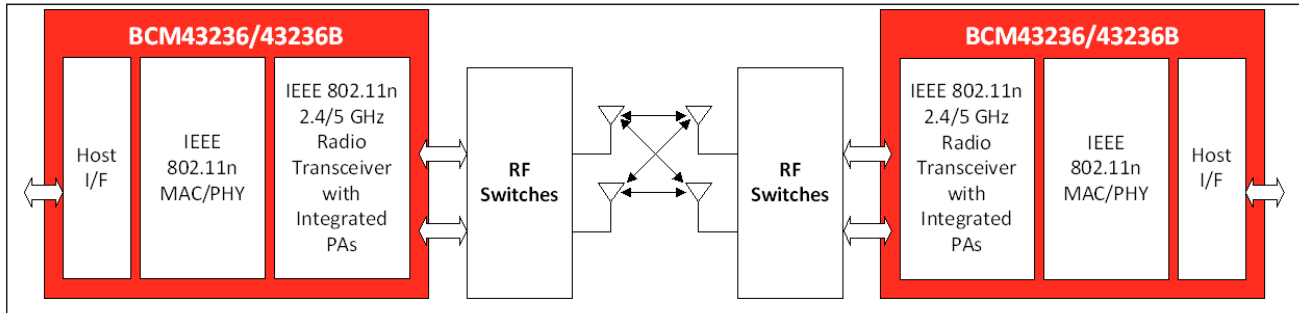

Employing a native 32-bit bus with Direct Memory Access (DMA) architecture, the BCM43236/BCM43236B chips offer significant performance improvements in transfer rates, CPU utilization, and flexible support for USB 2.0 devices.

Not Recommended for New Designs

Figure 3 shows a block diagram of the device.

Figure 3: Functional Block Diagram

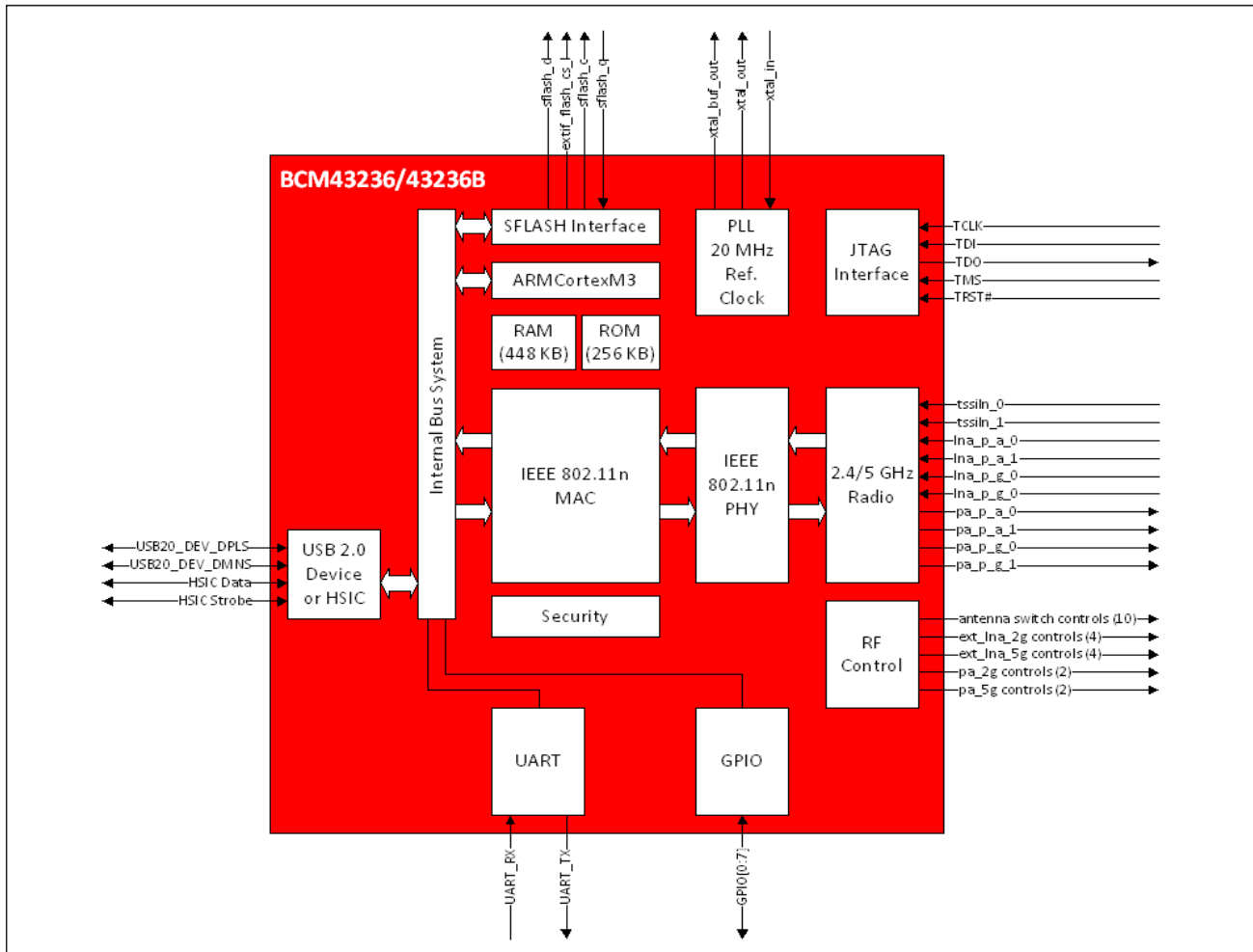

Not Recommended for New Designs

Section 2: Functional Description

Global Functions

Power Management

The BCM43236/BCM43236B chips have been designed with the stringent power consumption requirements of battery-powered hosts in mind. All areas of the chip design were scrutinized to help reduce power consumption. Silicon processes and cell libraries were chosen to reduce leakage current and supply voltages.

The BCM43236/BCM43236B chips include an advanced Power Management Unit (PMU). The PMU provides significant power savings by putting the BCM43236/BCM43236B into various power management states appropriate to the current environment and activities that are being performed. The power management unit enables and disables internal regulators, switches, and other blocks based on a computation of the required resources and a table that describes the relationship between resources and the time needed to enable and disable them. Power-up sequences are fully programmable. Configurable, free-running counters in the PMU are used to turn on/off individual regulators and power switches. Clock speeds are dynamically changed (or gated altogether) for the current mode. Slower clock speeds are used wherever possible.

Voltage Regulators

Three Low-Dropout (LDO) regulators and a PMU are integrated into the BCM43236/BCM43236B. All regulators are programmable via the PMU.

Reset

Resets are generated internally by the BCM43236/BCM43236B. An optional external power-on reset circuit can be connected to the active-low Ext_por input pin. A 50 ms low pulse is recommended to guarantee that a sufficiently long reset is applied to all internal circuits, including integrated PHYs. The initialization process loads all pin-configurable modes, resets all internal processes, and puts the device in the idle state. During initialization, the clock source input signal must be active, and the 3.3V power supply to the device must be stable. The external power-on reset overrides the BCM43236/BCM43236B internal reset.

GPIO Interface

There are eight General-Purpose I/O (GPIO) pins provided on the BCM43236/BCM43236B. They are multiplexed with the control signals. These pins can be used to attach to various external devices. Upon power-up and reset, these pins become tristated. Subsequently, they can be programmed to be either input or output pins via the GPIO control register. A programmable internal pull-up/pull-down resistor is included on each GPIO. If a GPIO output enable is not asserted, and the corresponding GPIO signal is not being driven externally, the GPIO state is determined by its programmable resistor.

Not Recommended for New Designs

Bluetooth Coexistence Interface

A 5-wire handshake interface is provided to enable signalling between the device and an external Bluetooth device host to manage sharing of the wireless medium for optimum performance. The signals provided are:

- btcx_tx_conf
- btcx_rf_active
- btcx_status
- btcx_pri_sel
- btcx_freq



Note: These five pins are muxed with the JTAG interface.

OTP

The BCM43236/BCM43236B chips contain an on-chip One-Time-Programmable (OTP) area that can be used for nonvolatile storage of WLAN information such as a MAC address and other hardware-specific parameters. The total area available for programming is 2 Kbits.

JTAG Interface

The BCM43236/BCM43236B chips support the IEEE 1149.1 JTAG boundary-scan standard for testing the device packaging and PCB manufacturing.

UART Interface

One UART interface is provided that can be attached to RS-232 Data Termination Equipment (DTE) for exchanging and managing data with other serial devices. The UART interface is primarily used for debugging and development.

Serial Flash Interface

Serial flash is available regardless of whether USB 2.0 operation is enabled or disabled. The flash interface is an STMicroelectronics®-compatible 4-pin interface.

USB/HSIC Interface

The BCM43236/BCM43236B USB/HSIC interface can be set to operate as a USB 2.0 port or a High-Speed Inter-Chip (HSIC) port. Features of the interface are:

- USB 2.0 protocol engine:
 - Parallel Interface Engine (PIE) between packet buffers and USB transceiver
 - Supports up to nine endpoints, including Configurable Control Endpoint 0
- Separate endpoint packet buffers with a 512-byte FIFO buffer each
- Host-to-device communication for bulk, control, and interrupt transfers
- Configuration/status registers
- The HSIC port can communicate with an external HSIC host, such as the BCM5357 and BCM5358.

The various blocks in the USB 2.0 device/HSIC core are shown in [Figure 4](#).

Figure 4: USB 2.0 Device/HSIC Core Block Diagram

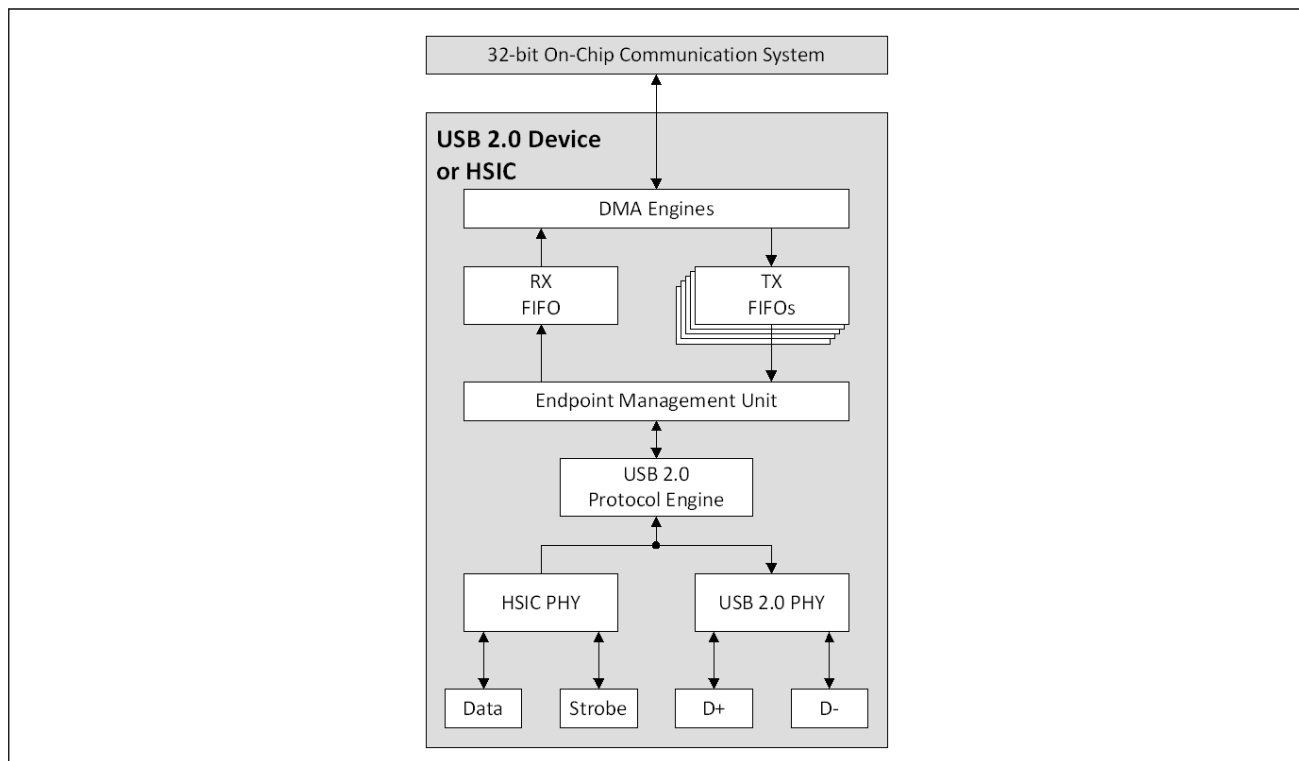

The USB 2.0 PHY handles the USB protocol and the serial signaling interface between the host and device. It is primarily responsible for data transmission and recovery. On the transmit side, data is encoded, along with a clock, using the NRZI scheme with bit stuffing to ensure that the receiver detects a transition in the data stream. A SYNC field that precedes each packet enables the receiver to synchronize the data and clock recovery circuits. On the receive side, the serial data is deserialized, unstuffed, and checked for errors. The recovered data and clock are then shifted to the clock domain that is compatible with the internal bus logic.

The endpoint management unit contains the PIE control logic and the endpoint logic. The PIE interfaces between the packet buffers and the USB transceiver. It handles packet identification (PID), USB packets, and transactions.

The endpoint logic contains nine uniquely-addressable endpoints. These endpoints are the source or sink of communication flow between the host and the device. Endpoint zero is used as a default control port for both the input and output directions. The USB system software uses this default control method to initialize and configure the device information, and allows USB status and control access. Endpoint zero is always accessible after a device is attached, powered, and reset.

Endpoints are supported by 512-byte FIFO buffers, one for each IN endpoint and one shared by all OUT endpoints. Both TX and RX data transfers support a DMA burst of 4, which guarantees low latency and maximum throughput performance. The RX FIFO can never overflow by design. The maximum USB packet size cannot be more than 512 bytes.

The BCM43236/BCM43236B can be configured as a USB 2.0 device or as a PHY-less HSIC by selecting the appropriate strapping option. See [Table 4 on page 26](#) for information on how to select the strapping options.

Crystal Oscillator

[Table 1](#) lists the requirements for the crystal oscillator.

Table 1: Crystal Oscillator Requirements

Parameter	Value
Frequency	20 MHz
Mode	AT cut, fundamental
Load capacitance	16 pF
ESR	50Ω maximum
Frequency stability	±10 ppm at 25°C ±10 ppm at 0°C to +85°C
Aging	±3 ppm/year max first year, ±1 ppm thereafter
Drive level	300 μW maximum
Q-factor	40,000 minimum
Shunt capacitance	< 5 pF

[Figure 5](#) shows the recommended oscillator configuration.

Figure 5: Recommended Oscillator Configuration

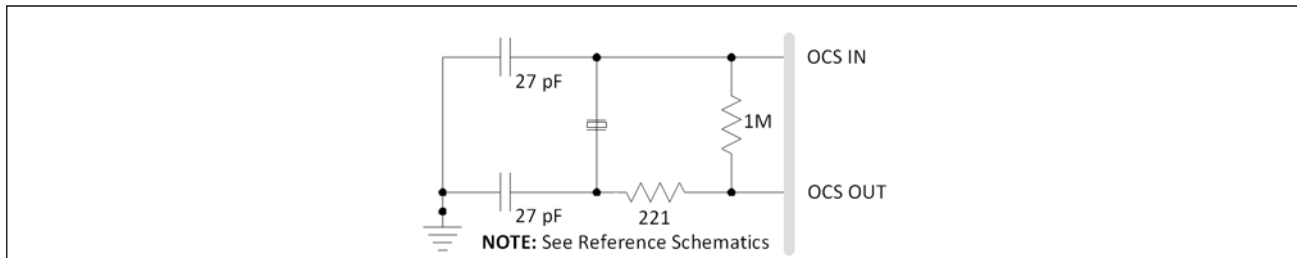

IEEE 802.11n MAC Description

The IEEE 802.11n MAC features include:

- Enhanced MAC for supporting IEEE 802.11n features
- Programmable Access Point (AP) or Station (STA) functionality
- Programmable Independent Basic Service Set (IBSS) or infrastructure mode
- Aggregated MPDU (MAC Protocol Data Unit) support for High-throughput (HT)
- Passive scanning
- Network Allocation Vector (NAV), Interframe Space (IFS), and Timing Synchronization Function (TSF) functionality
- RTS/CTS procedure
- Transmission of response frames (ACK/CTS)
- Address filtering of receive frames as specified by IBSS rules
- Multirate support
- Programmable Target Beacon Transmission Time (TBTT), beacon transmission/cancellation and programmable Announcement Traffic Indication Message (ATIM) window
- CF conformance: Setting NAV for neighborhood Point Coordination Function (PCF) operation
- Security through a variety of encryption schemes including WEP, TKIP, AES, WPA™, WAP2™, and IEEE 802.1X
- Power management
- Statistics counters for MIB support

The MAC core supports the transmission and reception of sequences of packets, together with related timing, without any packet-by-packet driver interaction. Time-critical tasks requiring response times of only a few milliseconds are handled in the MAC core. This achieves the required timing on the medium while keeping the host driver easier to write and maintain. Also, incoming packets are buffered in the MAC core, which allows the MAC driver to process them in bursts, enabling high bandwidth performance.

The MAC driver interacts with the MAC core to prepare queues of packets to transmit and to analyze and forward received packets to upper software layers. The internal blocks of the MAC core are connected to a Programmable State Machine (PSM) through the host interface that connects to the internal bus (see Figure 6).

Figure 6: Enhanced MAC Block Diagram

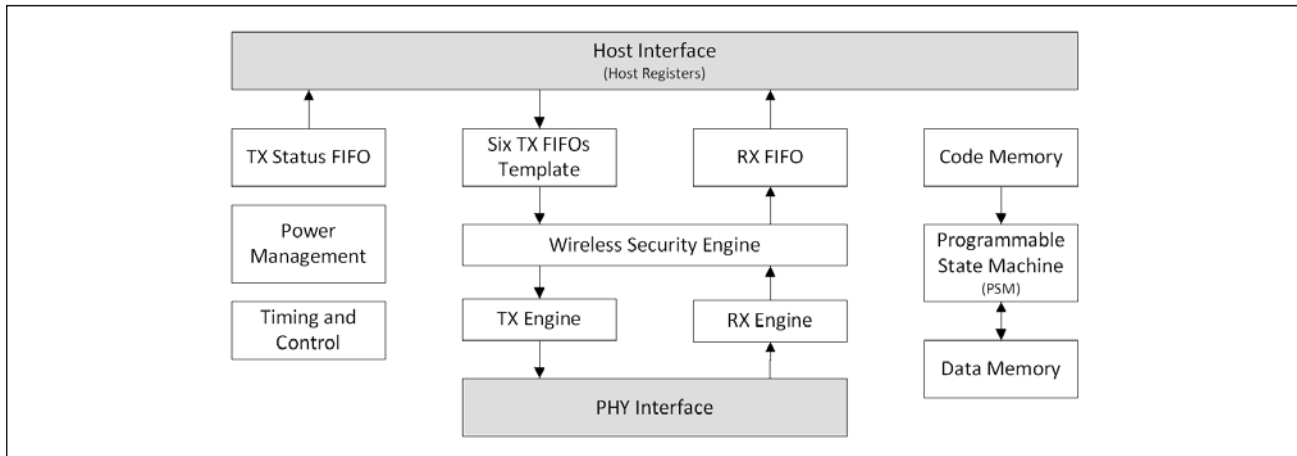

The host interface consists of registers for controlling and monitoring the status of the MAC core and interfacing with the TX/RX FIFOs. For transmit, a total of 128 KB FIFO buffering is available that can be dynamically allocated to six transmit queues plus template space for beacons, ACKs, and probe responses. Whenever the host has a frame to transmit, the host queues the frame into one of the transmit FIFOs with a TX descriptor containing TX control information. The PSM schedules the transmission on the medium depending on the frame type, transmission rules in IEEE 802.11 protocol, and the current medium occupancy scenario. After the transmission is completed, a TX status is returned to the host, informing the host of the result that got transmitted.

The MAC contains a single 10 KB RX FIFO. When a frame is received, it is sent to the host along with an RX descriptor that contains additional information about the frame reception conditions.

The power management block maintains the information regarding the power management state of the core (and the associated STAs in case of an AP) to help in dynamic decisions by the core regarding frame transmission.

The wireless security engine performs the required encryption/decryption on the TX/RX frames. This block supports separate transmit and receive keys with four shared keys and 50 link-specific keys. The link-specific keys are used to establish a secure link between any two STAs, with the required key being shared between only those two STAs, hence excluding all of the other STAs in the same network from deciphering the communication between those two STAs. The wireless security engine supports the following encryption schemes that can be selected on a per-destination basis:

- None: The wireless security engine acts as a pass-through
- WEP: 40-bit secure key and 24-bit IV as defined in IEEE Std. 802.11-2007
- WEP128: 104-bit secure key and 24-bit IV
- TKIP: IEEE Std. 802.11-2007
- AES: IEEE Std. 802.11-2007

The transmit engine is responsible for the byte flow from the TX FIFO to the PHY interface through the encryption engine and the addition of an FCS (CRC-32) as required by IEEE 802.11-2007. Similarly, the receive engine is responsible for byte flow from the PHY interface to the RX FIFO through the decryption engine and for detection of errors in the RX frame.

The timing block performs the TSF, NAV, and IFS functionality as described in IEEE Std. 802.11-2007.

The Programmable State Machine (PSM) coordinates the operation of different hardware blocks required for both transmission and reception. The PSM also maintains the statistics counters required for MIB support.

IEEE 802.11n PHY Description

The PHY features include:

- Programmable data rates from MCS 0–15 in 20 MHz and 40 MHz channels, as specified in IEEE 802.11n.
- Support for Short Guard Interval (SGI) and Space-Time Block Coding (STBC)
- All scrambling, encoding, forward error correction, and modulation in the transmit direction, and inverse operations in the receive direction
- Advanced digital signal processing technology for best-in-class receive sensitivity
- Both mixed-mode and optional greenfield preamble of IEEE 802.11n
- Both long and optional short preambles of IEEE 802.11b
- Resistance to multipath (>250 nanoseconds RMS delay spread) with maximal ratio combining for high throughput and range performance, including improved performance in legacy mode over existing IEEE 802.11a/b/g solutions.
- Automatic Gain Control (AGC)
- Available per-packet channel quality and signal strength measurements

The dual PHYs integrated in the BCM43236/BCM43236B chips provide baseband processing at all mandatory data rates specified in IEEE 802.11n up to 300 Mbps, and the legacy rates specified in IEEE 802.11a/b/g including 1, 2, 5.5, 6, 9, 11, 12, 18, 24, 36, 48, and 54 Mbps. This core acts as an intermediary between the MAC and the dual-band 2.4/5 GHz radio, converting back and forth between packets and baseband waveforms.

Figure 7: PHY Block Diagram

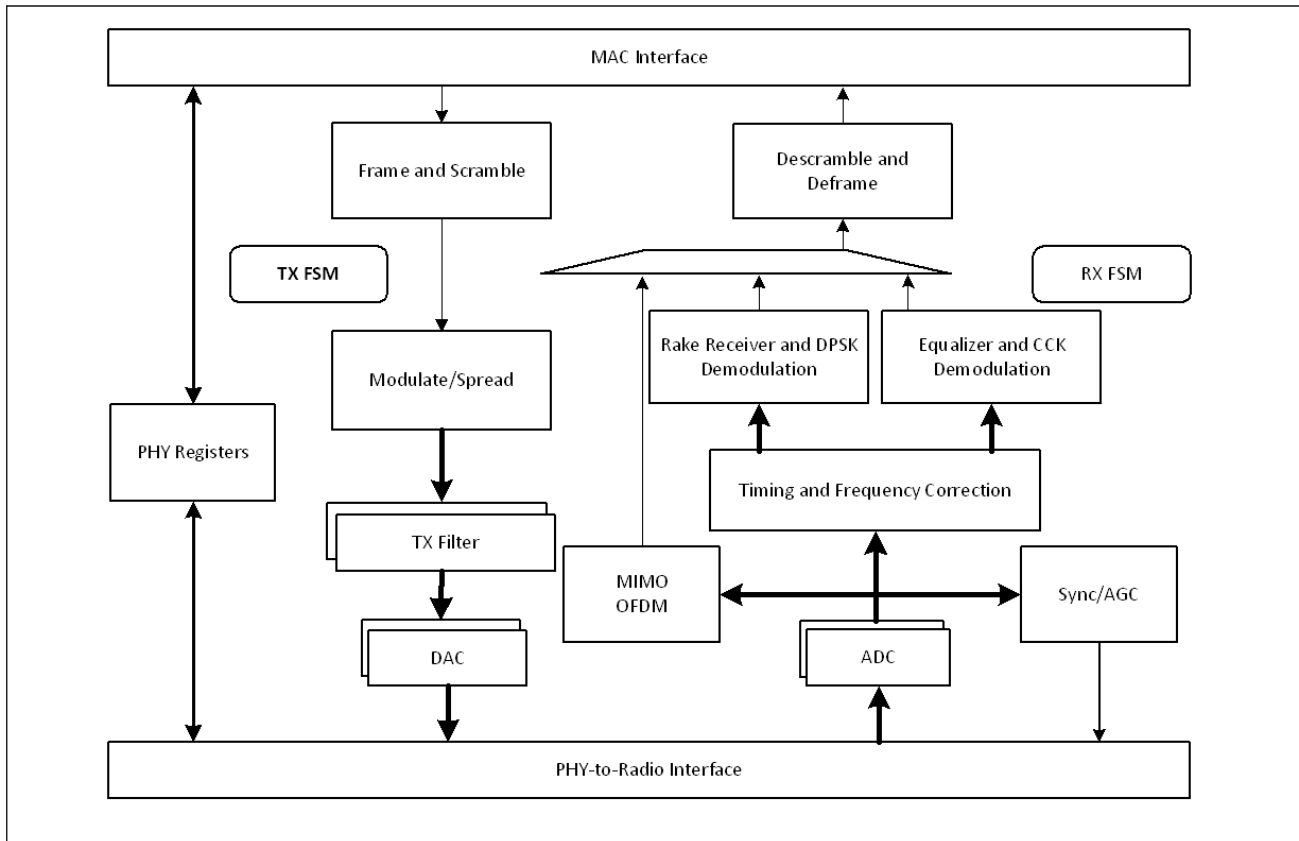

Not Recommended for New Designs

Dual-Band Radio Transceiver

Integrated into the BCM43236/BCM43236B chips is Broadcom's world-class dual-band radio transceiver that ensures low power consumption and robust communications for low-cost applications operating in the 2.4 GHz and 5 GHz bands. Channel bandwidths of 20 MHz and 40 MHz are supported as specified in IEEE 802.11n.

Receiver Path

The BCM43236/BCM43236B chips have a wide dynamic range, direct conversion receiver. It employs high order on-chip channel filtering to ensure reliable operation in the noisy 2.4 GHz ISM band or the entire 5 GHz U-NII band. The excellent noise figure of the receiver makes an external LNA unnecessary.

Transmitter Path

Baseband data is modulated and upconverted to the 2.4 GHz ISM band or the 5 GHz U-NII bands, respectively. Linear on-chip Power Amplifiers are included, which are capable of delivering a nominal output power exceeding +15 dBm while meeting the IEEE 802.11a and 802.11g specifications. The TX gain has a 78 dB range with a resolution of 0.25 dB.

Calibration

The BCM43236/BCM43236B chips feature dynamic on-chip calibration, eliminating process variation across components. This enables the device to be used in high-volume applications because calibration routines are not required during manufacturing testing. These calibration routines are performed periodically in the course of normal radio operation.

Not Recommended for New Designs

Section 3: Pin Assignments

This sections contains pin assignments and ballout information for the BCM43236/BCM43236B (88-pin) packages.

BCM43236/BCM43236B 88-Pin QFN Assignments

		88	87	86	85	84	83	82	81	80	79	78	77	76	75	74	73	72	71	70	69	68	67		
		VDD	mimophy_core0_ant1_tx	mimophy_core0_ant1_tx	gpio_6	gpio_5	VDDIO	gpio_4	gpio_3	gpio_2	gpio_1	gpio_0	VDD	VDDIO/OTP_VDD	USB_RREF	HSIC_STRB	HSIC_DATA	USB_AVDD_1p2	USB_DMINS	USB_DPLS	USB_AVDD3p3	USB_MONCDR	USBVDD2p5		
1	VDDIO																						VDD	66	
2	sflash_cs_l																							mimophy_core1_ant1_rx	65
3	sflash_q																							mimophy_core1_ant1_tx	64
4	sflash_c																							VDDIO	63
5	sflash_d																							UART_RX	62
6	mimophy_core0_ant0_tx																							UART_TX	61
7	mimophy_core0_ant0_rx																							VDD	60
8	VDD																							VDDPLL/RF_AVDD_1p2	59
9	mimophy_core1_ant0_tx																							USBLDO_2p5_out	58
10	mimophy_core1_ant0_rx																							LDO_3p3_in	57
11	VDDIO																							VREF	56
12	VDD																							PAREF	55
13	gpio_7																							PAREF_CTL1	54
14	jtag_trst_l																							PAREF_CTL2	53
15	jtag_tdi																							Ext_por	52
16	jtag_tck																							xtal_buf_out	51
17	analog_wlan_iqtest_VDD1p2																							i_xtal_VDD2p5/o_xtal_VDD2p5	50
18	jtag_tms																							xtal_in	49
19	jtag_tdo																							xtal_out	48
20	analog_wlan_iqtest_qp																							synth_VDD1p2	47
21	analog_wlan_iqtest_qn																							synth_vco_VDD1p2	46
22	analog_wlan_iqtest_in																							vreg3p3_VDD3p3	45
BCM43236/BCM43236B 10 x 10 QFN																									
		analog_wlan_iqtest_ip																							
23		Gnd																							
24		pa_5g_core1_VDD3p3																							
25		pa_5g_core1																							
26		tx_5g_core1_VDD1p2																							
27		rf_5g_antenna_core1																							
28		core1_VDD1p2																							
29		rf_2g_antenna_core1																							
30		tx_2g_core1_VDD1p2																							
31		pa_2g_core1_VDD3p3																							
32		pa_2g_core1																							
33		pa_5g_core0_VDD3p3																							
34		pa_5g_core0																							
35		tx_5g_core0_VDD1p2																							
36		rf_5g_antenna_core0																							
37		core0_VDD1p2																							
38		rf_2g_antenna_core0																							
39		tx_2g_core0_VDD1p2																							
40		pa_2g_core0_VDD3p3																							
41		pa_2g_core0																							
42		gpio_GPIO_PAD																							
43		rcal_res_ext_core																							
44																									

Figure 8: BCM43236/BCM43236B 88-Pin QFN Package

Not Recommended for New Designs

Signals by Pin Number

Table 2: Pin Assignments

<i>Pin Signal Name</i>	<i>Pin Signal Name</i>	<i>Pin Signal Name</i>	<i>Pin Signal Name</i>
1 VDDIO	23 analog_wlan_iqtest_ip	46 synth_vco_VDD1p2	68 USB_MONCDR
2 sflash_cs_l	24 Gnd	47 synth_VDD1p2	69 USB_AVDD3p3
3 sflash_q	25 pa_5g_core1_VDD3p3	48 xtal_out	70 USB_DPLS
4 sflash_c	26 PA_5g_core1	49 xtal_in	71 USB_DMNS
5 sflash_d	27 tx_5g_core1_VDD1p2	50 i_xtal_VDD2p5/ o_xtal_VDD2p5	72 USB AVDD 1p2
6 mimophy_core0_ant0_tx	28 rf_5g_antenna_core1	51 xtal_buf_out	73 HSIC_DATA
7 mimophy_core0_ant0_rx	29 core1_VDD1p2	52 Ext_por	74 HSIC_STRB
8 VDD	30 rf_2g_antenna_core1	53 PAREF_CTL2	75 USB_RREF
9 mimophy_core1_ant0_tx	31 tx_2g_core1_VDD1p2	54 PAREF_CTL1	76 VDDIO/OTP_VDD
10 mimophy_core1_ant0_rx	32 pa_2g_core1_VDD3p3	55 PAREF	77 VDD
11 VDDIO	33 PA_2g_core1	56 VREF	78 gpio_0
12 VDD	34 pa_5g_core0_VDD3p3	57 LDO_3p3_in	79 gpio_1
13 gpio_7	35 PA_5g_core0	58 USBLDO_2p5_out	80 gpio_2
14 jtag_trst_l	36 tx_5g_core0_VDD1p2	59 VDDPLL/RF_AVDD_1p2	81 gpio_3
15 jtag_tdi	37 rf_5g_antenna_core0	60 VDD	82 gpio_4
16 jtag_tck	38 core0_VDD1p2	61 UART_TX	83 VDDIO
17 analog_wlan_iqtest_VDD 1p2	39 rf_2g_antenna_core0	62 UART_RX	84 gpio_5
18 jtag_tms	40 tx_2g_core0_VDD1p2	63 VDDIO	85 gpio_6
19 jtag_tdo	41 pa_2g_core0_VDD3p3	64 mimophy_core1_ant1_tx	86 mimophy_core0_ant1_tx
20 analog_wlan_iqtest_qp	42 PA_2g_core0	65 mimophy_core1_ant1_rx	87 mimophy_core0_ant1_rx
21 analog_wlan_iqtest_qn	43 gpiao_GPIO_PAD	66 VDD	88 VDD
22 analog_wlan_iqtest_in	44 rcal_res_ext_core	67 USBVDD2p5	
	45 vreg3p3_VDD3p3		

Not Recommended for New Designs

Section 4: Signal and Pin Descriptions

Package Signal Descriptions

The signal name, type, and description of each pin in the BCM43236/BCM43236B 88-pin QFN package is listed in Table 3. The symbols shown under Type indicate pin directions (I/O = bidirectional, I = input, O = output) and the internal pull-up/pull-down characteristics (PU = weak internal pull-up resistor and PD = weak internal pull-down resistor), if any. See also Table 4 on page 26 for resistor strapping options.

Table 3: Signal Descriptions

Signal	BCM43236/ BCM43236B	Type	Description
Crystal Oscillator			
xtal_in	49	I	XTAL oscillator input. Connect a 20 MHz, 10 ppm crystal between the xtal_in and xtal_out pins.
xtal_out	48	O	XTAL oscillator output
xtal_buf_out	51	O	Buffered XTAL output
Serial Flash Interface			
sflash_cs_l	2	O (8 mA-PU)	Serial flash chip select
sflash_q	3	I (8 mA-PU)	Serial flash data input
sflash_c	4	O (8 mA-PD)	Serial flash clock
sflash_d	5	O (8 mA)	Serial flash data output
USB Interface			
usb_dmns	71	I/O	USB interface port D-
usb_dpns	70	I/O	USB interface port D+
usb_rref	75	O	During USB mode, tie this pin in parallel through a 100 pF capacitor and a 4 kΩ resistor to ground. During HSIC mode, tie this pin to a 50Ω resistor to ground.
hsic_strb	74	O	USB HSIC strobe
hsic_data	73	I/O	USB HSIC data
usb_moncdr	68	–	For test/diagnostic purposes only.
Miscellaneous Signals			
rcal_res_ext_core	44	O	Reference output, connect to ground via 15k 1% resistor.
ext_por	52	I	External power-on reset (POR) input. Active low. Allows an optional external power-on reset circuit to be connected. If installed, the external POR will override the internal POR.

Table 3: Signal Descriptions (Cont.)

Signal	BCM43236/ BCM43236B	Type	Description
analog_wlan_iqtest_qp	20	–	IQ test pin
analog_wlan_iqtest_qn	21	–	IQ test pin
analog_wlan_iqtest_in	22	–	IQ test pin
analog_wlan_iqtest_ip	23	–	IQ test pin
RF Control Interface			
mimophy_core0_ant0_tx	6	O	Antenna0 TR Switch controls for core 0. These pins are also used as strapping options, see Table 4 on page 26 .
mimophy_core0_ant0_rx	7		
mimophy_core0_ant1_tx	86	O	Antenna1 TR Switch controls for core 0. These pins are also used as strapping options, see Table 4 on page 26 .
mimophy_core0_ant1_rx	87		
mimophy_core1_ant0_tx	9	O	Antenna0 TR Switch controls for core 1. These pins are also used as strapping options, see Table 4 .
mimophy_core1_ant0_rx	10		
mimophy_core1_ant1_tx	64	O	Antenna1 TR Switch controls for core 1. These pins are also used as strapping options, see Table 4 .
mimophy_core1_ant1_rx	65		
RF Signal Interface			
rf_5g_antenna_core0	37	I	Chain 0 RF receive input, 5 GHz band
rf_5g_antenna_core1	28	I	Chain 1 RF receive input, 5 GHz band
rf_2g_antenna_core0	39	I	Chain 0 RF receive input, 2.4 GHz band
rf_2g_antenna_core1	30	I	Chain 1 RF receive input, 2.4 GHz band
pa_5g_core0	35	O	Chain 0 RF transmit output, 5 GHz band
pa_5g_core1	26	O	Chain 1 RF transmit output, 5 GHz band
pa_2g_core0	42	O	Chain 0 RF transmit output, 2.4 GHz band
pa_2g_core1	33	O	Chain 1 RF transmit output, 2.4 GHz band
JTAG Interface			
jtag_trst_l	14	I/O	JTAG Reset Input. Resets the JTAG Controller. If not used, this pin should be pulled low by a 1 k Ω resistor. This pin is muxed with gpio0.
jtag_tck	16	I/O	JTAG Test Clock Input. Used to synchronize JTAG control and data transfers. If not used, this pin should be pulled low by a 1 k Ω resistor. This pin is muxed with btcx_rf_active (Bluetooth coexistence output, RF active).
jtag_tdi	15	I/O	JTAG Test Data Input. Serial data input to the JTAG TAP controller. Sampled on the rising edge of TCK. If not used, it may be left unconnected. This pin is muxed with btcx_tx_conf (Bluetooth coexistence output, WLAN transmit).

Table 3: Signal Descriptions (Cont.)

Signal	BCM43236/ BCM43236B	Type	Description
jtag_tdo	19	I/O	JTAG Test Data Output. Serial data output from the JTAG TAP controller. Sampled on the rising edge of TCK. If not used, it may be left unconnected. This pin is muxed with btcx_prisel (Bluetooth coexistence output, antenna select).
jtag_tms	18	I/O	JTAG Mode Select Input. Single control input to the JTAG TAP controller used to traverse the test logic state machine. Sampled on the rising edge of TCK. If not used, it may be left unconnected. This pin is muxed with btcx_status (Bluetooth coexistence output, status).
GPIO Interface			
gpio_0	78	I/O (8 mA)	General Purpose I/O pin. This pin is tristated on power-up and reset. Subsequently, it becomes an input or an output through software control. A programmable PU or PD resistor is available for each GPIO pin. This pin is muxed with wlan_led (WLAN LED output).
gpio_1	79	I/O	General Purpose I/O pin. This pin is muxed with mimophy_core0_ant_shd (antenna switch control for the shared [middle] antenna of a 2 of 3 design [core 0]).
gpio_2	80	I/O	General Purpose I/O pin. This pin is muxed with: <ul style="list-style-type: none"> mimophy_core1_ant_shd: antenna switch control for the shared (middle) antenna of a 2 of 3 design (core 1). btcx_freq: Bluetooth coexistence RF frequency
gpio_3	81	I/O	General Purpose I/O pin.
gpio_4	82	I/O	General Purpose I/O pin. This pin is muxed with: <ul style="list-style-type: none"> ext_lna_2g_pu_0: 2.4 GHz band core 0 power amplifier control ext_pa_2g_0: 2.4 GHz band core 0 power amplifier control CS: SPI select
gpio_5	84	I/O	General Purpose I/O pin. This pin is muxed with: <ul style="list-style-type: none"> ext_lna_2g_pu_1: 2.4 GHz band core 1 power amplifier control ext_pa_2g_1: 2.4 GHz band core 1 power amplifier control SCLK: SPI clock I2C_SCL: I²C clock

Table 3: Signal Descriptions (Cont.)

Signal	BCM43236/ BCM43236B	Type	Description
gpio_6	85	I/O	General Purpose I/O pin. This pin is muxed with: <ul style="list-style-type: none"> ext_lna_5g_pu_0: 5 GHz band core 0 power amplifier control ext_pa_5g_0: 5 GHz band core 0 power amplifier control SDI: SPI data input
gpio_7	13	I/O	General Purpose I/O pin. This pin is muxed with: <ul style="list-style-type: none"> ext_lna_5g_pu_1: 5 GHz band core 1 power amplifier control ext_pa_5g_1: 5 GHz band core 1 power amplifier control SDO: SPI data output I2C_SDA: I²C data
gpiao_gpio_pad	43	–	Connect 0.1 μ F bypass cap
UART Interface			
UART_RX	62	I/O (4 mA PU)	UART receive data
UART_TX	61	I/O (4 mA)	UART transmit data
Power and Ground			
vdd	8, 12, 60, 66, 77, 88	PWR	1.2V supply input for the core logic.
vddio	1, 11, 63, 83	PWR	3.3V supply input for I/O logic
vddio/otp_vdd	76	PWR	3.3V supply input for I/O logic
usbavdd2p5	67	PWR	USB analog power supply
usbldo_2p5_out	58	PWR	USB LDO output; decouple to ground.
usb_avdd3p3	69	PWR	3.3V supply input to USB interface
usbavdd1p2	72	PWR	1.2V supply input to USB interface
synth_vdd1p2	47	PWR	Analog 1.2V supply input
synth_vco_vdd1p2	46	PWR	Analog 1.2V supply input
core0_vdd1p2	38	PWR	Analog 1.2V supply input
core1_vdd1p2	29	PWR	Analog 1.2V supply input
tx_5g_core0_vdd1p2	36	PWR	Analog 1.2V supply input
tx_5g_core1_vdd1p2	27	PWR	Analog 1.2V supply input
tx_2g_core0_vdd1p2	40	PWR	Analog 1.2V supply input
tx_2g_core1_vdd1p2	31	PWR	Analog 1.2V supply input
pa_5g_core0_vdd3p3	34	PWR	Filtered 3.3V input to internal PA
pa_5g_core1_vdd3p3	25	PWR	Filtered 3.3V input to internal PA
pa_2g_core0_vdd3p3	41	PWR	Filtered 3.3V input to internal PA
pa_2g_core1_vdd3p3	32	PWR	Filtered 3.3V input to internal PA

Table 3: Signal Descriptions (Cont.)

Signal	BCM43236/ BCM43236B	Type	Description
analog_wlan_iqtest_vdd_1p2	17	PWR	1.2V power supply for IQ test.
ldo_3p3_in	57	PWR	3.3V input to RF LDO
vddpll/rf_avdd_1p2	59	O	XTAL power reference; decouple to ground.
vreg3p3_vdd3p3	45	PWR	Analog 3.3V supply
i_xtal_vdd2p5/o_xtal_vdd2p5	50	O	Connect with bypass cap.
vref	56	–	VREF; decouple to ground.
paref	55	–	PA reference; decouple to ground.
paref_ctl1	54	–	PA reference control 1
paref_ctl2	53	–	PA reference control 2
gnd_slug	H	GND	Ground
gnd	24	GND	Ground

Strapping Options

The pins listed in Table 4 are sampled at Power-on Reset (POR) to determine the various operating modes. Sampling occurs within a few milliseconds following internal POR or deassertion of external POR. After POR, each pin assumes the function specified in the signal descriptions table. Each pin has an internal pull-up (PU) or pull-down (PD) resistor that determines the default mode. To change the mode, connect an external PU resistor to VDDIO or a PD resistor to GND; use 10 kΩ or less (refer to the reference board schematics for further details).

Table 4: Strapping Options

Signal Name	Mode	Default	Description
mimophy_core0_ant0_tx	OTP select	PU	0: No OTP 1: OTP present
mimophy_core1_ant0_tx	SFLASH not present	PD	0: SFLASH not present 1: SFLASH present
mimophy_core0_ant0_rx	ST SFLASH	PD	0: SFLASH type is STMicroelectronics 1: SFLASH type is Atmel®
mimophy_core0_ant1_tx	USB PHY	PU	0: HSIC mode 1: USB PHY mode
mimophy_core0_ant1_rx	120 MHz	PU	0: Backplane at 96 (98.4) MHz 1: Backplane at 120 (123) MHz
gpio[7:6]	Boot from ROM	No pull	00: Remap to RAM; ARM processor to be held at reset. 01: Boot from ROM unless the ARM needs to be held at reset.

Section 5: Electrical Characteristics



Note: Values in this data sheet are design goals and are subject to change based on the results of device characterization.

Absolute Maximum Ratings



Caution! The specifications in Table 5 define levels at which permanent damage to the device can occur. Functional operation is not guaranteed under these conditions. Operation at absolute maximum conditions for extended periods can adversely affect the long-term reliability of the device.

Table 5: Absolute Maximum Ratings

Rating	Symbol	Minimum	Maximum	Unit	
DC supply voltage for core	VDDC	-0.5	+1.4	V	
DC supply voltage for I/O	VDDO	-0.5	+3.8	V	
Voltage on any input or output pin	V_{IMAX}, V_{IMIN}	-0.5	+3.8 ^a	V	
Ambient Temperature (Operating)	T_A	0	+65 ^b	°C	
Operating Junction Temperature 125°C	T_J	-	125	°C	
Operating Humidity	-	-	85	%	
Storage Temperature	T_{STG}	-40	+125	°C	
Storage Humidity	-	-	60	%	
ESD Protection	(HBM)	V_{ESD}	-	2000	V
	(CDM)		-	500	V
	(MM)		-	150	V
	(LU)		-	200	mV

- The max voltage requirement is to not exceed $VDDO + 0.5V$ when $VDDO < 3.3V$.
- The temperature above the shield is 65°C for the T_J to be less than 125°C with a P_{out} of 15 dBm.

Not Recommended for New Designs

Recommended Operating Conditions and DC Characteristics

Table 6: Recommended Operating Conditions and DC Characteristics

Element	Symbol	Value			Unit
		Minimum	Typical	Maximum	
DC supply voltage for I/O	VDDO	2.97	3.3	3.63	V
DC supply voltage for core and 1.2V analog	VDD12	1.14	1.2	1.26	V
Input low voltage (VDDO = 3.3V)	V _{IL}	–	–	0.8	V
Input high voltage (VDDO = 3.3V)	V _{IH}	2.0	–	–	V
Output low voltage	V _{OL}	–	–	0.4	V
Output high voltage	V _{OH}	VDDO – 0.4V	–	–	V

Current Consumption from the 3.3V Supply

Table 7: Current Consumption from 3.3V Supply

Item	Typical	Maximum	Units
Radio disabled state	29	48	mA
Idle and associated state, PM2 mode	120	148	mA
Active state, TX or RX, 40 MHz channel, maximum throughput, PM2 mode	462	716	mA

Current Consumption from the 1.2V Supply

Table 8: Current Consumption from 1.2V Supply

Item	Typical	Maximum	Units
Radio disabled state	47	68	mA
Idle and associated state, PM2 mode	228	296	mA
Active state, TX or RX, 40 MHz channel, maximum throughput, PM2 mode	510	708	mA

Not Recommended for New Designs

HSIC Characteristics

Table 9: HSIC Characteristics

Parameter	Symbol	Minimum	Typical	Maximum	Unit	Comments
HSIC signaling voltage	V_{DD}	1.1	1.2	1.3	V	–
I/O voltage input low	V_{IL}	–0.3	–	$0.35 \times V_{DD}$	V	–
I/O Voltage input high	V_{IH}	$0.65 \times V_{DD}$	–	$V_{DD} + 0.3$	V	–
I/O voltage output low	V_{OL}	–	–	$0.25 \times V_{DD}$	V	–
I/O voltage output high	V_{OH}	$0.75 \times V_{DD}$	–	–	V	–
I/O pad drive strength	O_D	40	–	60	Ω	Controlled output impedance driver
I/O weak keepers	I_L	20	–	70	mA	–
I/O input impedance	Z_I	100	–	–	k Ω	–
Total capacitive load ^a	C_L	3	–	14	pF	–
Characteristic trace impedance	T_I	45	50	55	Ω	–
Circuit board trace length	T_L	–	–	10	cm	–
Circuit board trace propagation skew ^b	T_S	–	–	15	ps	–
STROBE frequency ^c	F_{STROBE}	239.988	240	240.012	MHz	± 500 ppm
Slew rate (rise and fall) STROBE and DATA ^c	T_{slew}	$0.60 \times V_{DD}$	1.0	1.2	V/ns	Averaged from 30% ~ 70% points
Receiver data setup time (with respect to STROBE) ^c	T_S	300	–	–	ps	Measured at the 50% point
Receiver data hold time (with respect to STROBE) ^c	T_b	300	–	–	ps	Measured at the 50% point

- Total Capacitive Load (C_L), includes device Input/Output capacitance, and capacitance of a 50 Ω PCB trace with a length of 10 cm.
- Maximum propagation delay skew in STROBE or DATA with respect to each other. The trace delay should be matched between STROBE and DATA to ensure that the signal timing is within specification limits at the receiver.
- Jitter and duty cycle are not separately specified parameters: they are incorporated into the values in the table above.

Section 6: RF Specifications



Note: Values in this data sheet are design goals and are subject to change based on the results of device characterization.

2.4 GHz Band General RF Specifications

Table 10: 2.4 GHz Band General RF Specifications

<i>Item</i>	<i>Condition</i>	<i>Minimum</i>	<i>Typical</i>	<i>Maximum</i>	<i>Unit</i>
aRxTxTurnaroundTime	Including switch time	–	–	2	μs

Not Recommended for New Designs

2.4 GHz Band Receiver RF Specifications

Table 11: 2.4 GHz Band Receiver RF Specifications

<i>Characteristic</i>	<i>Condition</i>	<i>Minimum</i>	<i>Typical</i>	<i>Maximum</i>	<i>Unit</i>
Cascaded Noise Figure	–	–	4.5	–	dB
Maximum Receive Level ^a	@ 1, 2 Mbps	–4	–	–	dBm
	@ 5.5, 11 Mbps	–10	–	–	dBm
	@ 54 Mbps	–10	–	–	dBm
Input IP3	Maximum gain	–	–16	–	dBm
	Minimum gain	–	–2	–	dBm
LPF 3 dB Bandwidth	–	8	8.5	9	MHz
PGA DC Rejection Servo Loop Bandwidth	WB mode	–	1	–	MHz
	NB mode	120 Hz	–	230 kHz	–
LPF DC Rejection Servo Loop Bandwidth	WB mode	–	500	–	kHz
	NB mode	120 Hz	–	230 kHz	–
Maximum Receiver Gain	–	–	88	–	dB
Gain Control Step	–	–	3	–	dB/step
Rx Sensitivity	20 MHz channel spacing for all MCS rates				
(10% PER for 4096 octet PSDU) at WLAN RF port. Defined for default parameters: GF, 800 ns GI, and non-STBC.	MCS0 OFDM	–	–91	–	dBm
	MCS7 OFDM	–	–74	–	dBm
	MCS8 OFDM	–	–88.5	–	dBm
	MCS15 OFDM	–	–69	–	dBm
	40 MHz channel spacing for all MCS rates				
	MCS0 OFDM	–	–88	–	dBm
	MCS7 OFDM	–	–71	–	dBm
	MCS8 OFDM	–	–85.5	–	dBm
MCS15 OFDM	–	–66	–	dBm	

a. When using a suitable external switch.

Not Recommended for New Designs

2.4 GHz Band Transmitter RF Specifications

Table 12: 2.4 GHz Band Transmitter RF Specifications

Characteristic	Condition	Minimum	Typical	Maximum	Unit
RF Output Frequency Range	–	2400	–	2500	MHz
TX Output Power					
BCM43236	20 MHz BW	–	–	16	dBm
	40 MHz BW	–	–	14.5	dBm
BCM43236B	20 MHz BW	–	–	18	dBm
	40 MHz BW	–	–	15.5	dBm
Carrier Suppression	–	15	–	–	dBr
TX Spectrum mask @ maximum gain	$f_c - 22 \text{ MHz} < f < f_c - 11 \text{ MHz}$	–	–	–30	dBr
	$f_c + 11 \text{ MHz} < f < f_c + 22 \text{ MHz}$	–	–	–30	dBr
	$f < f_c - 22 \text{ MHz}$; and $f > f_c + 22 \text{ MHz}$	–	–	–50	dBr
TX Modulation Accuracy (EVM) at maximum gain	IEEE 802.11b mode	–	–	35%	–
	IEEE 802.11g mode	–	–	5%	–
Gain Control Step Size	–	–	0.25	–	dB/step
I/Q Baseband Bandwidth	IEEE 802.11b mode	–	12	–	MHz
	IEEE 802.11g mode	–	12	–	MHz
Amplitude Balance ^a	DC input	–1	–	1	dB
Phase Balance ^a	DC input	–1.5	–	1.5	°C
Baseband Differential Input Voltage	Shaped pulse	–	0.6	–	V _{pp}

a. At a 3 MHz offset from the carrier frequency.

2.4 GHz Band Local Oscillator Specifications

Table 13: 2.4 GHz Band Local Oscillator Specifications

Characteristic	Condition	Minimum	Typical	Maximum	Unit
VCO Frequency Range	–	2412	–	2484	MHz
Reference Input Frequency Range	–	–	20	–	MHz
Clock Frequency Tolerance	–	–	–	±20	ppm
Reference Spurs	–	–	–	–34	dBc
Local Oscillator Phase Noise, single-sided from 1 kHz–300 kHz offset	–	–	–	–86.5	dBc/Hz

Not Recommended for New Designs

5 GHz Band Receiver RF Specifications

Table 14: 5 GHz Band Receiver RF Specifications^a

Characteristic	Condition	Minimum	Typical	Maximum	Unit
Cascaded Noise Figure	Maximum RX gain	–	4.5	–	dB
Maximum Receive Level ^a (5.24 GHz)	@ 6 Mbps	–10 (TBV)	–	–	dBm
Maximum Receive Level ^a (5.24 GHz)	@ 54 Mbps	–15 (TBV)	–	–	dBm
Input IP3	Maximum LNA gain	–	–5	–	dBm
	Minimum LNA gain	–	–4	–	dBm
LPF 3 dB Bandwidth	–	–	8.5	–	MHz
DC Rejection Servo Loop Bandwidth (normal operation)	WB mode	–	500	–	kHz
	NB mode	120 Hz	–	230 kHz	–
Minimum RX Gain	–	–	15	–	dB
Maximum RX Gain	–	–	92	–	dB
Gain Control Step	–	–	3	–	dB/step
IQ Amplitude Balance	–	–	0.5	–	dB
IQ Phase Balance	–	–	1.5	–	°C
Out-of-Band Blocking Performance without RF Band-Pass Filter (–1 dB desensitization):					
CW	30 MHz–4300 MHz	–10 (TBV)	–	–	dBm
CW	4300 MHz–4800 MHz	–25 (TBV)	–	–	dBm
CW	5900 MHz–6400 MHz	–25 (TBV)	–	–	dBm
Rx Sensitivity (10% PER for 4096 octet PSDU) at WLAN RF port. Defined for default parameters: GF, 800 ns GI, and non-STBC.	20 MHz channel spacing for all MCS rates				
	MCS0 OFDM	–	–90	–	dBm
	MCS7 OFDM	–	–74	–	dBm
	MCS8 OFDM	–	–88.5	–	dBm
	MCS15 OFDM	–	–69	–	dBm
	40 MHz channel spacing for all MCS rates				
	MCS0 OFDM	–	–87	–	dBm
	MCS7 OFDM	–	–71	–	dBm
	MCS8 OFDM	–	–86	–	dBm
	MCS15 OFDM	–	–66	–	dBm

a. With minimum RF gain.

Not Recommended for New Designs

5 GHz Band Transmitter RF Specifications

Table 15: 5 GHz Band Transmitter RF Specifications

Characteristic	Condition	Minimum	Typical	Maximum	Unit
RF Output Frequency Range	–	4920	–	5805	MHz
Output Power (EVM-compliant)					
BCM43236	20 MHz BW	–	–	15	dBm
	40 MHz BW	–	–	14	dBm
BCM43236B	20 MHz BW	–	–	16.5	dBm
	40 MHz BW	–	–	15	dBm
Carrier Suppression	–	–	–	TBD	dBr
TX Spectrum mask (chip output power = 11 dBm)	$f < f_c - 11$ MHz and $f > f_c + 11$ MHz	–	–	–26	dBc
	$f < f_c - 20$ MHz and $f > f_c + 20$ MHz	–	–	–35	dBr
	$f < f_c - 30$ MHz and $f > f_c + 30$ MHz	–	–	–40	dBr
TX Modulation Accuracy (EVM) $P_o = 11$ dBm	–	–	–25	–	dB
TX Modulation Accuracy (EVM) $P_o = 6$ dBm	–	–	–33	–	dB
Gain Control Step Size	–	–	2	–	dB/step
I/Q Baseband 3 dB Bandwidth	–	–	12	–	MHz
Amplitude Balance	DC Input	–0.5	–	0.5	dB
Phase Balance	DC Input	–1.5	–	1.5	°C
Baseband Differential Input Voltage	–	–	0.7	–	Vpp
TX Power Ramp Up	90% of final power	–	–	2	µsec
TX Power Ramp Down	10% of final power	–	–	2	µsec

5 GHz Band Local Oscillator Frequency Generator Specifications

Table 16: 5 GHz Band Local Oscillator Frequency Generator Specifications

Characteristic	Condition	Minimum	Typical	Maximum	Unit
VCO Frequency Range	–	4920	–	5805	MHz
Reference Input Frequency Range	–	–	20	–	MHz
Clock Frequency Tolerance	–	–	–	±20	ppm
Reference Spurs	–	–	–	–30	dBc
Local Oscillator Integrated Phase Noise (1 kHz–300 kHz)	4.920 GHz–5.700 GHz	–	0.7	–	°C
	5.725 GHz–5.805 GHz	–	1.4	–	

On-Chip Regulator Power Supply Characteristics

Table 17: On-Chip Regulator Power Supply Characteristics

Element	Value			Unit
	Minimum	Typical	Maximum	
2.5V–3.1V PA Reference LDO (default: off)				
Vout: 2.5V to 3.1V when output A, B, C and/or D is enabled.				
Control Step: 50 mV/step				
Input Power Supply	2.97	3.3	3.63	V
Vout (Note 1) Programmable, 50 mV/step	2.5	2.85	3.1	V
Absolute Accuracy	–4	–	+4	%
Maximum Output Current: A, B, C and D all enabled	–	–	40	mA
Maximum Output Current: any output A, B, C, or D	–	–	10	mA
Dropout Voltage	150	–	–	mV
Startup Time	–	–	100	μs
Switching ON Time (either A or G)	20	30	100	ns
Note: LDO is already powered.				
Switching OFF Time (either A or G)	1	1.3	2	ns
Note: LDO is already powered.				
3.3V–1.2V RF LDO				
Input power supply, Vbat	2.97	3.30	3.63	V
Vout (Note 1) Programmable, 50 mV/step	1.2	–	3.0	V
Absolute Accuracy	–4	–	+4	%
Dropout Voltage	150	–	–	mV
Maximum Output Current	–	–	120	mA
Startup time with 100 μs VDD Ramp	–	–	50	μs
3.3V–2.5V USB LDO				
Input power supply	2.97	3.30	3.63	V
Vout	2.3	2.5	2.65	V
Absolute accuracy	–4	–	+4	%
Dropout voltage	150	–	–	mV
Maximum output current	–	–	30	mA
Start-up time	–	–	50	μs
Note: It is required that the input supply be at least 200 mV higher than the output. More headroom is better for PSRR performance.				

Section 7: Timing Characteristics

Reset and Clock Timing Diagram

Resets are generated internally by the BCM43236/BCM43236B chips. An optional external Power-On Reset (POR) circuit can be connected to the active-low Ext_por input pin. The BCM43236/BCM43236B chips are reset automatically as long as the power supplies are turned on in the following sequence. 3.3V first, 2.5V second, and 1.2V last.

Figure 9: Timing for the Optional External Power-On Reset

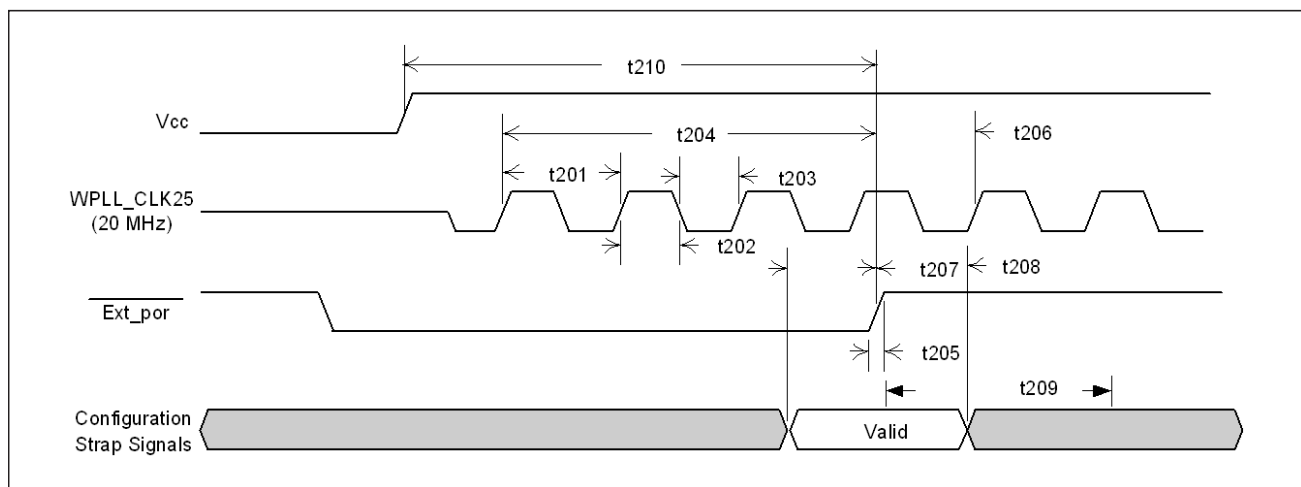

Table 18: Ext_por and Clock Timing

Parameter	Description	Minimum	Typical	Maximum	Units
t201	OSCIN frequency	19.9995	20.0000	20.0005	MHz
t202	OSCIN high time	–	20	–	ns
t203	OSCIN low time	–	20	–	ns
t204	EXT_POR_L low pulse duration	50	–	–	ms
t207	Configuration valid setup to EXT_POR_L rising	50	–	–	µs
t208	Configuration valid hold from EXT_POR_L rising	1.7	–	2.8	ms
t209	EXT_POR_L deassertion to normal switch operation	–	3	–	ms
t210	Reset low hold time after power supplies stabilize	50	–	–	ms

Not Recommended for New Designs

Serial Flash Timing Diagram

Figure 10: Serial Flash Timing Diagram (STMicroelectronics-Compatible)

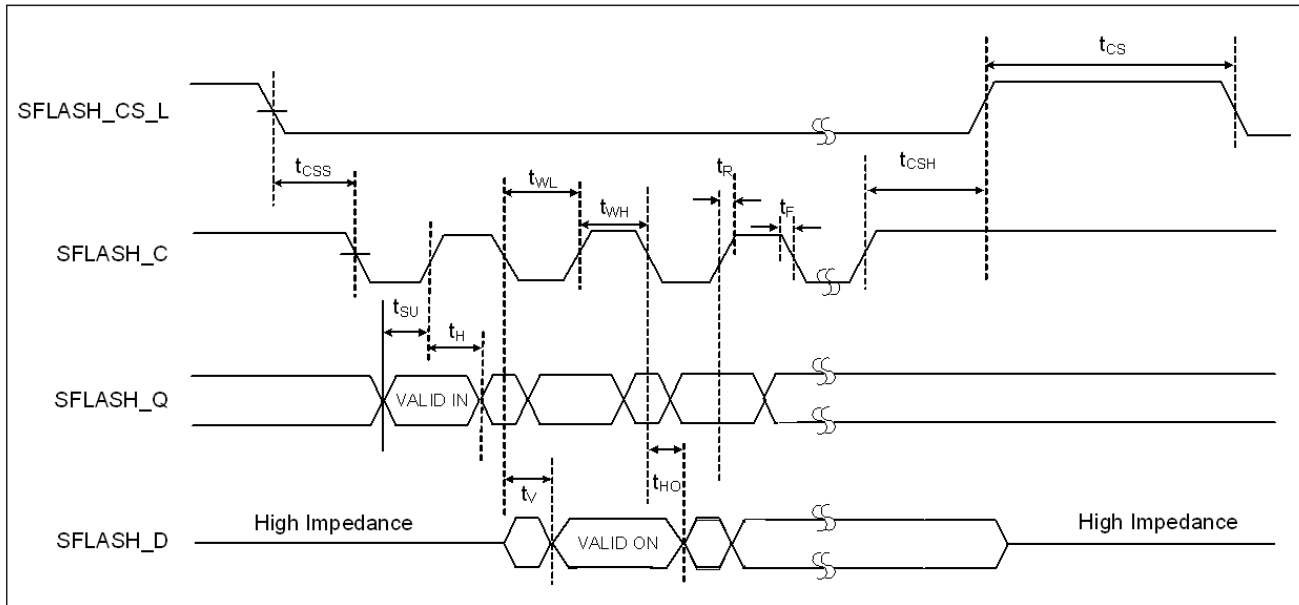

Table 19: Serial Flash Timing

Parameter	Descriptions	Minimum	Typical	Maximum	Units
f _{SCK}	Serial flash clock frequency	–	12.5	66	MHz
t _{WH}	Serial flash clock high time	9	–	–	ns
t _{WL}	Serial flash clock low time	9	–	–	ns
t _R , t _F ^a	Clock rise and fall times ^b	TBD	–	–	V/ns
t _{CSS}	Chip select active setup time	5	–	–	ns
t _{CS}	Chip select deselect time	100	–	–	ns
t _{CSH}	Chip select hold time	5	–	–	ns
t _{SU}	Data input setup time	2	–	–	ns
t _H	Data input hold time	5	–	–	ns
t _{HO}	Data output hold time	0	–	–	ns
t _V	Clock low to output valid	–	–	8	ns

a. t_R and t_F are expressed as a slew-rate.

b. Peak-to-peak

Not Recommended for New Designs

Figure 11 shows the power supply sequence.

Figure 11: Power Supply Sequence

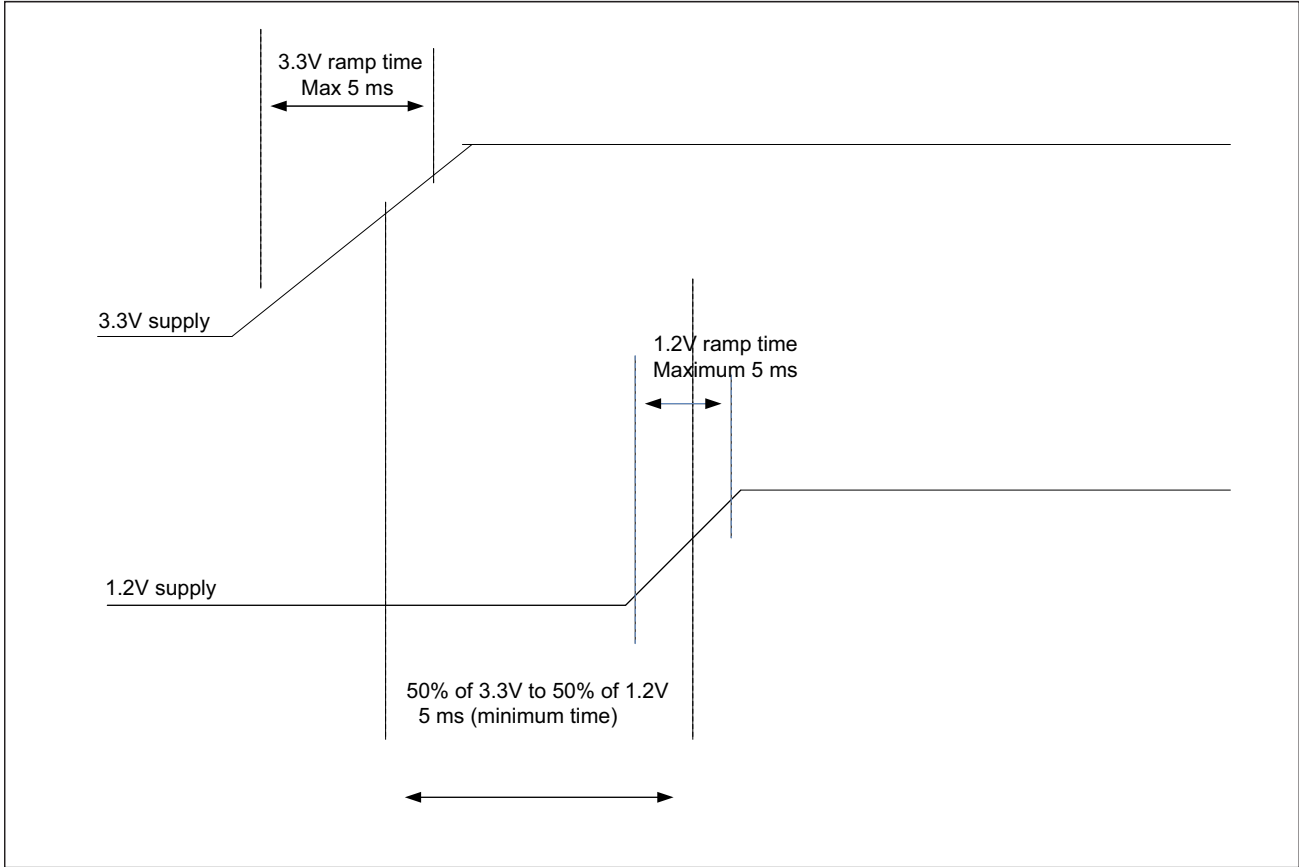

Not Recommended for New Designs

Section 8: Thermal Information

Table 20: 88-Pin QFN Thermal Characteristics

Airflow	0 fpm, 0 mps	100 fpm, 0.508 mps	200 fpm, 1.016 mps	400 fpm, 2.032 mps	600 fpm, 3.048 mps
θ_{JA} (°C/W)	20.79	17.55	16.24	15.00	14.34
θ_{JB} (°C/W)	3.95	–	–	–	–
θ_{JC} (°C/W)	12.44	–	–	–	–
Ψ_{JT} (°C/W)	3.51	3.50	3.55	3.59	3.61



Note:

- In the thermal characterizations that were done on BCM43236/BCM43236B chips using a 4-layer board, the temperature at 1 mm above the shield must be no higher than 65°C in order to keep the junction temperature (T_J) from exceeding 125°C.
- The BCM43236/BCM43236B chips are designed and rated for operation at a maximum T_J of 125°C.

Junction Temperature Estimation and Ψ_{JT} Versus θ_{JC}

Package thermal characterization parameter Ψ_{JT} (Ψ_{JT}) yields a better estimation of actual junction temperature (T_J) versus using the junction-to-case thermal resistance parameter θ_{JC} (θ_{JC}). The reason for this is θ_{JC} assumes that all the power is dissipated through the top surface of the package case. In actual applications, some of the power is dissipated through the bottom and sides of the package. Ψ_{JT} takes into account power dissipated through the top, bottom, and sides of the package. The equation for calculating the device junction temperature is as follows:

$$T_J = T_T + P \times \Psi_{JT}$$

Where:

- T_J = junction temperature at steady-state condition, °C
- T_T = package case top center temperature at steady-state condition, °C
- P = device power dissipation, Watts
- Ψ_{JT} = package thermal characteristics (no airflow), °C/W

Package thermal characterization measurements: The temperature above the shield is 65°C for the T_J to be less than 125°C with a P_{out} of 15 dBm.

Not Recommended for New Designs

Section 9: Package Information

Figure 12: BCM43236/BCM43236B Mechanical Drawing

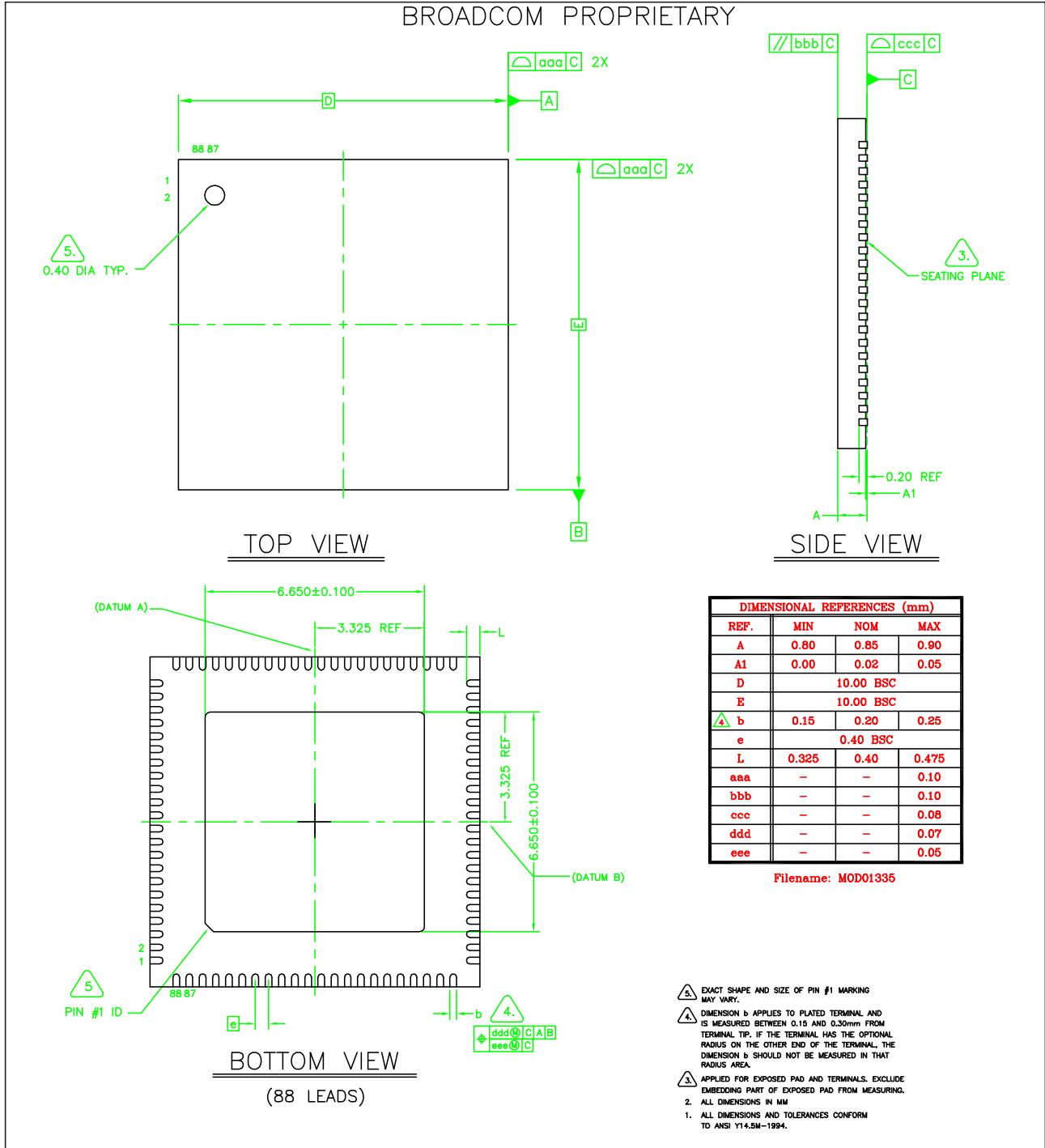

Not Recommended for New Designs

Section 10: Ordering Information

Table 21: Ordering Information

<i>Part Number</i>	<i>Package</i>	<i>Temperature @ 1 mm Above the Shield</i>
BCM43236KMLG	10 × 10, 88-pin QFN (RoHs compliant)	0°C to 65°C (32°F to 149°F)
BCM43236BKMLG	10 × 10, 88-pin QFN (RoHs compliant)	0°C to 65°C (32°F to 149°F)

Not Recommended for New Designs

Not Recommended for New Designs

Broadcom® Corporation reserves the right to make changes without further notice to any products or data herein to improve reliability, function, or design.

Information furnished by Broadcom Corporation is believed to be accurate and reliable. However, Broadcom Corporation does not assume any liability arising out of the application or use of this information, nor the application or use of any product or circuit described herein, neither does it convey any license under its patent rights nor the rights of others.

Connecting
everything®



BROADCOM CORPORATION

5300 California Avenue

Irvine, CA 92617

© 2013 by BROADCOM CORPORATION. All rights reserved.

43236_43236B-DS103-R September 16, 2013

Phone: 949-926-5000

Fax: 949-926-5203

E-mail: info@broadcom.com

Web: www.broadcom.com

Looking for pricing, stock, or lifecycle information?

Click below to explore more details on WIN SOURCE:

- ⊖ [View BCM43236BKMLGT on WIN SOURCE](#)
- ⊖ [Cypress Semiconductor Corp Information](#)

Optimize Your Supply Chain with WIN SOURCE Solutions

- ✓ Global Sourcing Solution
- ✓ Obsolete Management
- ✓ Cost Control Management
- ✓ Shortage Management
- ✓ Alternative Solution
- ✓ Excess Inventory Management