



Is Now Part of



ON Semiconductor®

To learn more about ON Semiconductor, please visit our website at
www.onsemi.com

Please note: As part of the Fairchild Semiconductor integration, some of the Fairchild orderable part numbers will need to change in order to meet ON Semiconductor's system requirements. Since the ON Semiconductor product management systems do not have the ability to manage part nomenclature that utilizes an underscore (_), the underscore (_) in the Fairchild part numbers will be changed to a dash (-). This document may contain device numbers with an underscore (_). Please check the ON Semiconductor website to verify the updated device numbers. The most current and up-to-date ordering information can be found at www.onsemi.com. Please email any questions regarding the system integration to Fairchild_questions@onsemi.com.

ON Semiconductor and the ON Semiconductor logo are trademarks of Semiconductor Components Industries, LLC dba ON Semiconductor or its subsidiaries in the United States and/or other countries. ON Semiconductor owns the rights to a number of patents, trademarks, copyrights, trade secrets, and other intellectual property. A listing of ON Semiconductor's product/patent coverage may be accessed at www.onsemi.com/site/pdf/Patent-Marking.pdf. ON Semiconductor reserves the right to make changes without further notice to any products herein. ON Semiconductor makes no warranty, representation or guarantee regarding the suitability of its products for any particular purpose, nor does ON Semiconductor assume any liability arising out of the application or use of any product or circuit, and specifically disclaims any and all liability, including without limitation special, consequential or incidental damages. Buyer is responsible for its products and applications using ON Semiconductor products, including compliance with all laws, regulations and safety requirements or standards, regardless of any support or applications information provided by ON Semiconductor. "Typical" parameters which may be provided in ON Semiconductor data sheets and/or specifications can and do vary in different applications and actual performance may vary over time. All operating parameters, including "Typicals" must be validated for each customer application by customer's technical experts. ON Semiconductor does not convey any license under its patent rights nor the rights of others. ON Semiconductor products are not designed, intended, or authorized for use as a critical component in life support systems or any FDA Class 3 medical devices or medical devices with a same or similar classification in a foreign jurisdiction or any devices intended for implantation in the human body. Should Buyer purchase or use ON Semiconductor products for any such unintended or unauthorized application, Buyer shall indemnify and hold ON Semiconductor and its officers, employees, subsidiaries, affiliates, and distributors harmless against all claims, costs, damages, and expenses, and reasonable attorney fees arising out of, directly or indirectly, any claim of personal injury or death associated with such unintended or unauthorized use, even if such claim alleges that ON Semiconductor was negligent regarding the design or manufacture of the part. ON Semiconductor is an Equal Opportunity/Affirmative Action Employer. This literature is subject to all applicable copyright laws and is not for resale in any manner.

FAN5333A/FAN5333B

High Efficiency, High Current Serial LED Driver with 30V Integrated Switch

Features

- 1.5MHz Switching Frequency
- Low Noise
- Adjustable Output Voltage
- Up to 1.5A Peak Switch Current
- 1.5W Output Power Capability
- Low Shutdown Current: $<1\mu\text{A}$
- Cycle-by-Cycle Current Limit
- Low Feedback Voltage
- Over-Voltage Protection
- Fixed-Frequency PWM Operation
- Internal Compensation
- FAN5333A has 110mV Feedback Voltage
- FAN5333B has 315mV Feedback Voltage
- Thermal Shutdown
- 5-Lead SOT23 Package

Description

The FAN5333A/FAN5333B is a general purpose LED driver that features fixed frequency mode operation and an integrated FET switch. The device's high output power makes it suitable to drive flash LEDs in serial connections. This device is designed to operate at high switching frequencies in order to minimize switching noise measured at the battery terminal of hand-held communications equipment. Quiescent current in both normal and shutdown mode is designed to be minimal in order to extend battery life. Normal or shutdown mode can be selected by a logic level shutdown circuitry.

The low ON-resistance of the internal N-channel switch ensures high efficiency and low power dissipation. A cycle-by-cycle current limit circuit keeps the peak current of the switch below a typical value of 1.5A. The FAN5333A/FAN5333B is available in a 5-lead SOT23 package.

Applications

- Cell Phones
- PDAs
- Handheld Equipment
- Display Bias
- LED Bias
- Flash LED

Typical Application

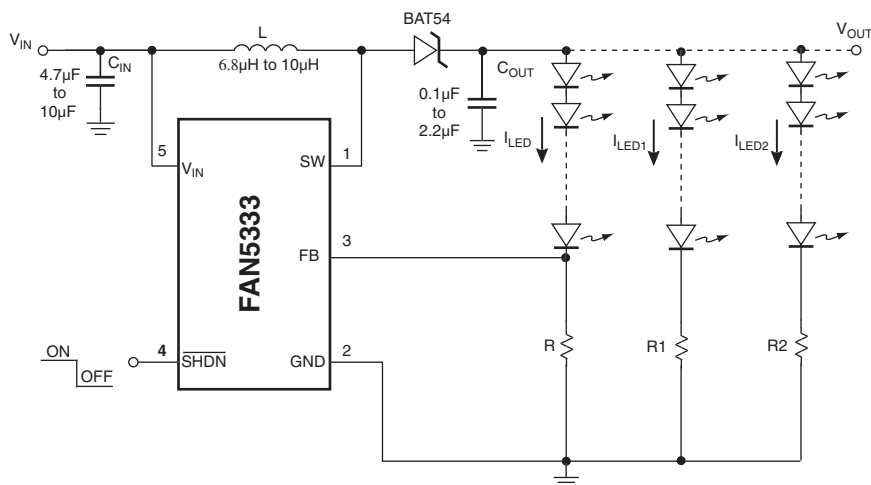
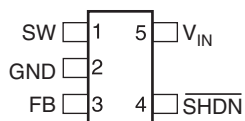

Figure 1. Typical Application Diagram

Pin Assignment

Top View



5-Lead SOT-23

Figure 2. Pin Assignment

Pin Description

Pin No.	Pin Name	Pin Description
1	SW	Switching Node.
2	GND	Analog and Power Ground.
3	FB	Feedback Pin. Feedback node that connects to an external current set resistor.
4	SHDN	Shutdown Control Pin. Logic HIGH enables, logic LOW disables the device.
5	V _{IN}	Input Voltage Pin.

Absolute Maximum Ratings (Note1)

Parameter	Min	Max	Unit
V_{IN} to GND		6.0	V
FB, SHDN to GND	-0.3	$V_{IN} + 0.3$	V
SW to GND	-0.3	35	V
Lead Soldering Temperature (10 seconds)		300	°C
Junction Temperature		150	°C
Storage Temperature	-55	150	°C
Thermal Resistance (Θ_{JA})		210	°C/W
Electrostatic Discharge Protection (ESD) Level (Note 2)	HBM	2	kV
	CDM	1	

Recommended Operating Conditions

Parameter	Min	Typ	Max	Unit
Input Voltage	1.8		5.5	V
Output Voltage	V_{IN}		30	V
Operating Ambient Temperature	-40	25	85	°C
Output Capacitance Rated at the Required Output (Note 3) for maximum load current	0.47			μ F

Notes:

- Stresses above those listed under “Absolute Maximum Ratings” may cause permanent damage to the device. This is a stress rating only and functional operation of the device at these or any other conditions above those indicated in the operational section of this specification is not implied. Exposure to absolute maximum rating conditions for extended periods may affect device reliability. Absolute maximum ratings apply individually only, not in combination.
- Using EIA/JESD22A114B (Human Body Model) and EIA/JESD22C101-A (Charge Device Model).
- This load capacitance value is required for the loop stability. Tolerance, temperature variation, and voltage dependency of the capacitance must be considered. Typically a 1 μ F ceramic capacitor is required to achieve specified value at $V_{OUT} = 30V$.

Electrical Characteristics

Unless otherwise noted, $V_{IN} = 3.6V$, $V_{OUT} = 20V$, $I_{LED} = 20mA$, $T_A = -40^{\circ}C$ to $85^{\circ}C$, Typical values are at $T_A = 25^{\circ}C$, Test Circuit, Figure 3.

Parameter	Conditions	Min.	Typ.	Max.	Units
Feedback Voltage	FAN5333A	99	110	121	mV
	FAN5333B	299	315	331	mV
Switch Current Limit	$V_{IN} = 3.2V$	1.1	1.5		A
Load Current Capability	$V_{OUT} \leq 20V$, $V_{IN} = 3.2V$	65			mA
Switch On-resistance	$V_{IN} = 5V$		0.6		Ω
	$V_{IN} = 3.6V$		0.7		Ω
Quiescent Current	$V_{SHDN} = 3.6V$, No Switching		0.6		mA
OFF Mode Current	$V_{SHDN} = 0V$		0.1	3	μA
Shutdown Threshold	Device ON	1.5			V
	Device OFF			0.5	V
Shutdown Pin Bias Current	$V_{SHDN} = 0V$ or $V_{SHDN} = 5.5V$		1	300	nA
Feedback Pin Bias Current			1	300	nA
Feedback Voltage Line Regulation	$2.7V < V_{IN} < 5.5V$, $V_{OUT} \leq 20V$		0.3		%
Switching Frequency		1.2	1.5	1.8	MHz
Maximum Duty Cycle		87	93		%
Switch Leakage Current	No Switching, $V_{IN} = 5.5V$			1	μA
OVP			15		%
Thermal Shutdown Temperature			150		$^{\circ}C$

Test Circuit

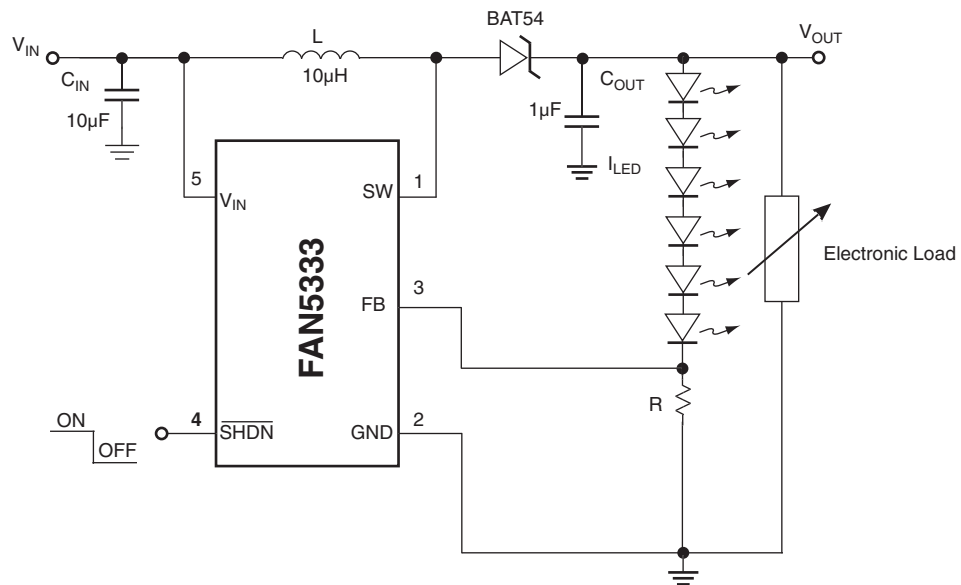
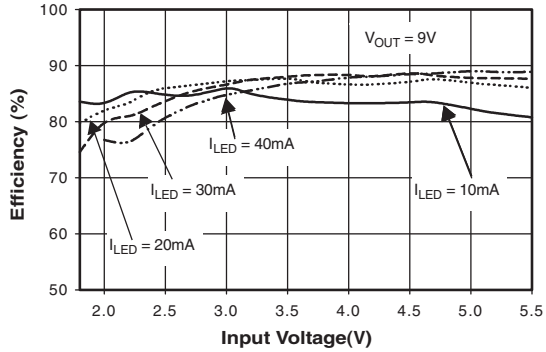

Figure 3. Test Circuit

Typical Performance Characteristics

$T_A = 25^\circ\text{C}$, $C_{IN} = 4.7\mu\text{F}$, $C_{OUT} = 0.47\mu\text{F}$, $L = 10\mu\text{H}$, unless otherwise noted.

Efficiency vs. Input Voltage



Efficiency vs. Input Voltage

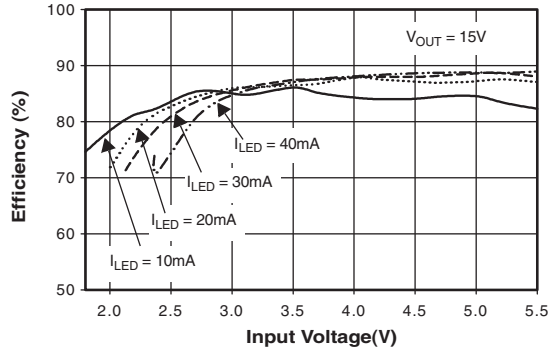

Maximum Load Current vs. Input Voltage

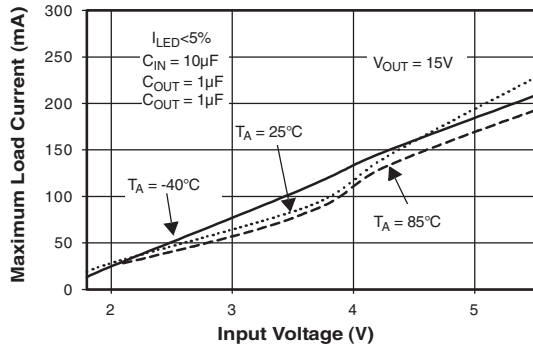

Maximum Load Current vs. Input Voltage

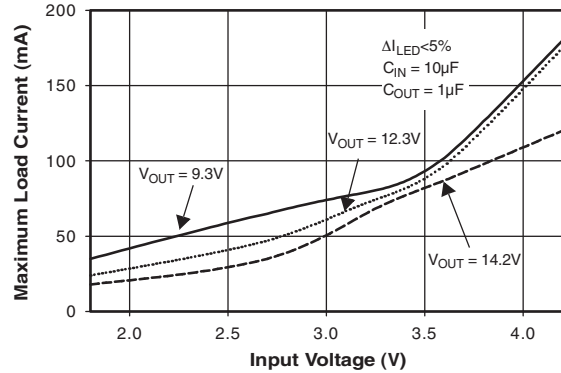

LED Current vs. Temperature

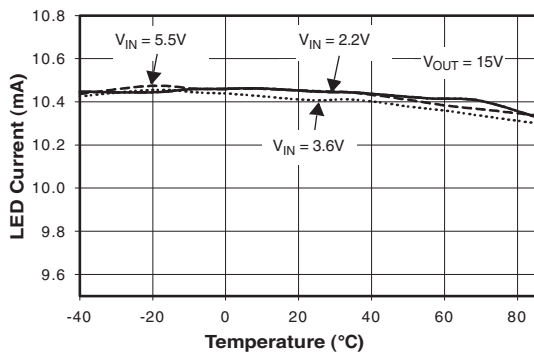

SW Frequency vs. Temperature

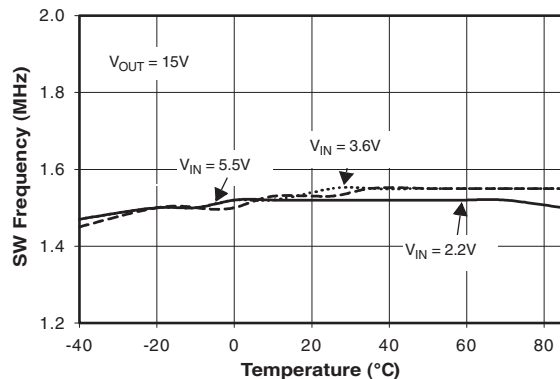

Typical Performance Characteristics (Contd.)

$T_A = 25^\circ\text{C}$, $C_{IN} = 4.7\mu\text{F}$, $C_{OUT} = 0.47\mu\text{F}$, $L = 10\mu\text{H}$, unless otherwise noted.

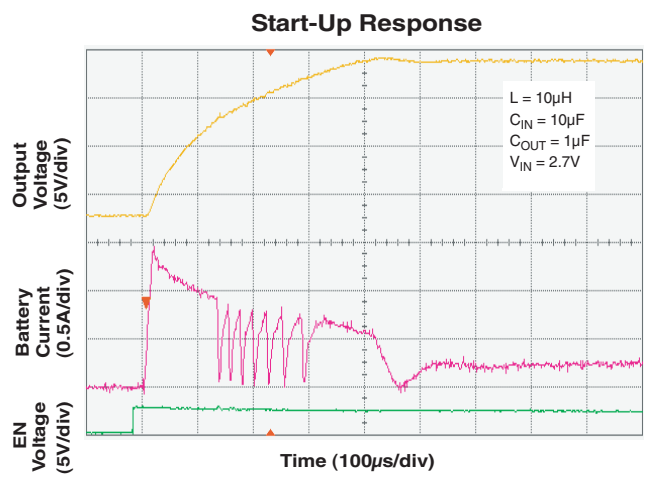
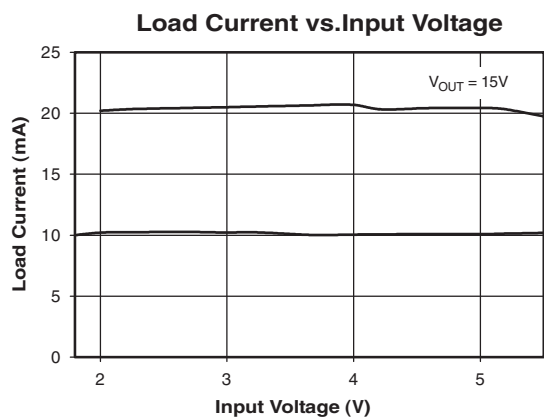

Block Diagram

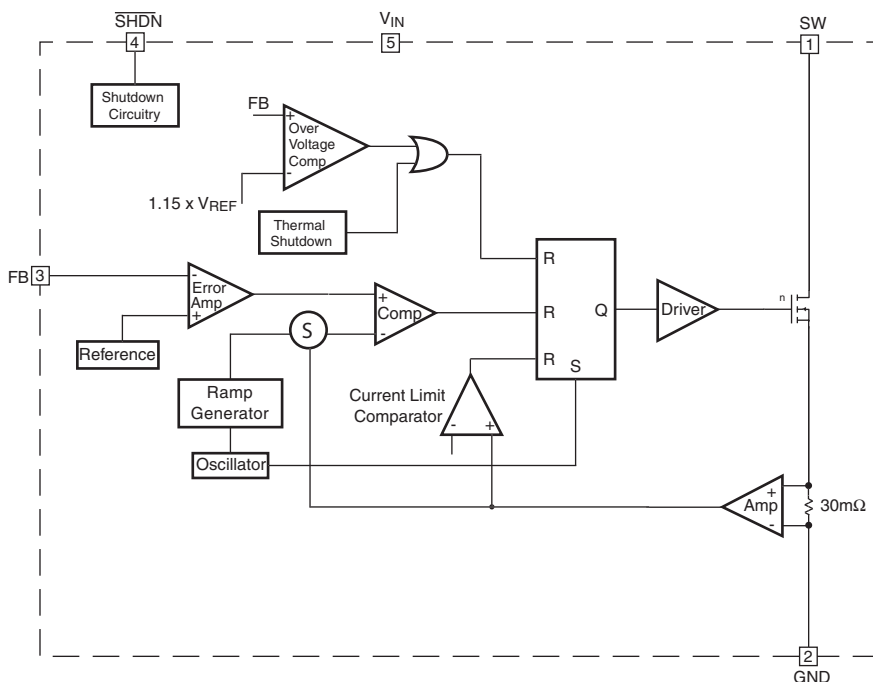

Figure 4. Block Diagram

Circuit Description

The FAN5333A/FAN5333B is a pulse-width modulated (PWM) current-mode boost converter. The FAN5333A/FAN5333B improves the performance of battery powered equipment by significantly minimizing the spectral distribution of noise at the input caused by the switching action of the regulator. In order to facilitate effective noise filtering, the switching frequency was chosen to be high, 1.5MHz. The device architecture is that of a current mode controller with an internal sense resistor connected in series with the N-channel switch. The voltage at the feedback pin tracks the output voltage at the cathode of the external Schottky diode (shown in the test circuit). The error amplifier amplifies the difference between the feedback voltage and the internal band-gap reference. The amplified error voltage serves as a reference voltage to the PWM comparator. The inverting input of the PWM comparator consists of the sum of two components: the amplified control signal received from the 30mΩ current sense resistor and the ramp generator voltage derived from the oscillator. The oscillator sets the latch, and the latch turns on the FET switch. Under normal operating conditions, the PWM comparator resets the latch and turns off the FET, thus terminating the pulse. Since the comparator input contains information about the output voltage and the control loop is arranged to form a negative feedback loop, the value of the peak inductor current will be adjusted to maintain regulation.

Every time the latch is reset, the FET is turned off and the current flow through the switch is terminated. The latch can be reset by other events as well. Over-current condition is monitored by the current limit comparator which resets the latch and turns off the switch instantaneously within each clock cycle.

Over-Voltage Protection

The voltage on the feedback pin is sensed by an OVP Comparator. When the feedback voltage is 15% higher than the nominal voltage, the OVP Comparator stops switching of the power transistor, thus preventing the output voltage from going higher.

Open-circuit protection

As in any current regulator, if the feedback loop is open, the output voltage increases until it is limited by some additional external circuitry. In the particular case of the FAN5333, the output voltage is limited by the switching transistor breakdown at around 45V, typically (assuming that C_{OUT} and the Schottky diode rating voltage are higher). Since at such high output voltage the output current is inherently limited by the discontinuous conduction mode, in most cases, the switching transistor enters non-destructive breakdown and the IC survives.

However, to ensure 100% protection for LED disconnection, we recommend limiting V_{OUT} with an external Zener diode or stopping the boost switching with an external voltage supervisory circuit.

Applications Information

Setting the Output Current

The internal reference (V_{REF}) is 110mV (Typical) for FAN5333A and 315mV (Typical) for FAN5333B. The output current is set by a resistor divider R connected between FB pin and ground. The output current is given by

$$I_{LED} = \frac{V_{FB}}{R}$$

Inductor Selection

The inductor parameters directly related to device performances are saturation current and dc resistance. The FAN5333A/FAN5333B operates with a typical inductor value of 10μH. The lower the dc resistance, the higher the efficiency. Usually a trade-off between inductor size, cost and overall efficiency is needed to make the optimum choice.

The inductor saturation current should be rated around 1A, in an application having the LED current near the maximum current as indicated in "Typical Performance Characteristics". The peak inductor current is limited to 1.5A by the current sense loop. This limit is reached only during the start-up and with heavy load condition; when this event occurs the converter can shift over in discontinuous conduction mode due to the automatic turn-off of the switching transistor, resulting in higher ripple and reduced efficiency.

Some recommended inductors are suggested in the table below:

Inductor Value	Vendor	Part Number	Comment
10μH	TDK	SLF6025&100M1R0	
10μH	MURATA	LQH66SN100M01C	Highest Efficiency
10μH	COOPER	SD414-100	Small Size

Table 1: Recommended Inductors

Capacitors Selection

For best performance, low ESR input and output capacitors are required. Ceramic capacitors of C_{IN} = 10μF and C_{OUT} = 1μF placed as close to the IC pins, are required for the maximum load (65mA). For the lighter load (≤ 20mA) the capacitances may be reduced to C_{IN} = 4.7μF and C_{OUT} = 0.47μF or even to 0.1μF, if higher ripple is acceptable. The output capacitor voltage rating should be according to the V_{OUT} setting. Some capacitors are suggested in the table below.

Capacitor Value	Vendor	Part Number
0.47μF	Panasonic	ECJ-3YB1E474K
1μF	Murata	GRM21BR61E105K
10μF	Murata	GRM21BR61A106K

Table 2: Recommended Capacitors

Diode Selection

The external diode used for rectification is usually a Schottky diode. Its average forward current and reverse voltage maximum ratings should exceed the load current and the voltage at the output of the converter respectively. A barrier Schottky diode such as BAT54 is preferred, due to its lower reverse current over the temperature range.

Care should be taken to avoid any short circuit of V_{OUT} to GND, even with the IC disabled, since the diode can be instantly damaged by the excessive current.

Brightness Control

1. Dimming Using PWM Logic Signal

A PWM signal applied to $\overline{\text{SHDN}}$ Table 5 on page 8 can control the LED's brightness in direct dependence with the duty cycle. The maximum frequency should not exceed 1kHz to ensure a linear dependence of the LED's average current. The amplitude of the PWM signal should be suitable to turn the FAN5333 ON and OFF.

Alternatively, a PWM logic signal can be used to switch a FET ON/OFF to change the resistance that sets the LED's current Table 6 on page 8. Adjusting the duty cycle from 0% to 100% results in varying the LED's current between I_{MIN} and I_{MAX}.

Where

$$I_{\text{MIN}} = \frac{V_{\text{FB}}}{R_{\text{MIN}}} \text{ and } I_{\text{MAX}} = \frac{V_{\text{FB}}}{R_{\text{MIN}} \parallel R_{\text{SET}}}$$

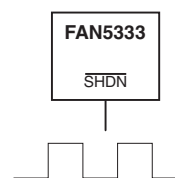

Figure 5. Dimming Using a PWM Signal

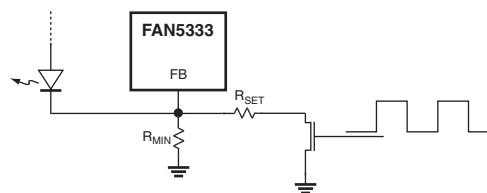

Figure 6. Dimming Using a PWM Logic Signal

2. Dimming Using DC Voltage

An external adjustable DC voltage Table 7 on page 8 between 0V to 2V can control the LED's current from 15mA to 0mA, respectively.

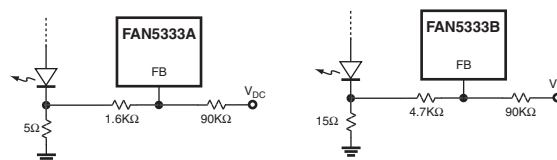

Figure 7. Dimming Using DC Voltage

3. Dimming Using Filtered PWM Signal

This method allows the use of a greater than 1kHz PWM frequency signal with minimum impact on the battery ripple. The filtered PWM signal Table 8 on page 9 acts as an adjustable DC voltage as long as its frequency is significantly higher than the corner frequency of the RC low pass filter.

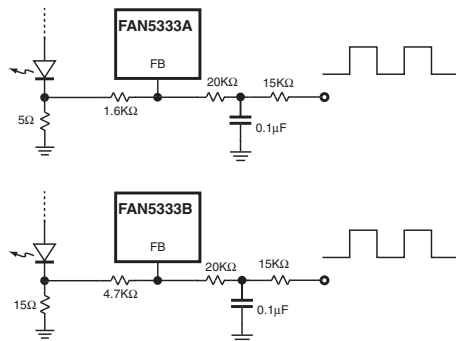

Figure 8. Dimming Using Filtered PWM Signal

Thermal Shutdown

When the die temperature exceeds 150°C, a reset occurs and will remain in effect until the die cools to 130°C, at that time the circuit will be allowed to restart.

PCB Layout Recommendations

The inherently high peak currents and switching frequency of power supplies require careful PCB layout design. Therefore, use wide traces for high current paths and place the input capacitor, the inductor, and the output capacitor as close as possible to the integrated circuit terminals. The FB pin connection should be routed away from the inductor proximity to prevent RF coupling. A PCB with at least one ground plane connected to pin 2 of the IC is recommended. This ground plane acts as an electromagnetic shield to reduce EMI and parasitic coupling between components.

Mechanical Dimensions

5-Lead SOT-23

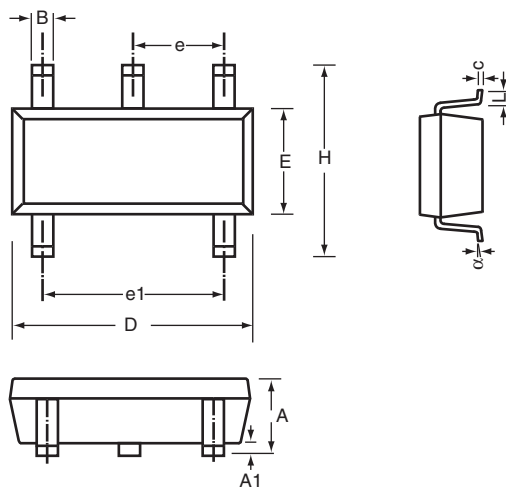

Symbol	Inches		Millimeters		Notes
	Min	Max	Min	Max	
A	.035	.057	.90	1.45	
A1	.000	.006	.00	.15	
B	.008	.020	.20	.50	
c	.003	.010	.08	.25	
D	.106	.122	2.70	3.10	
E	.059	.071	1.50	1.80	
e	.037 BSC		.95 BSC		
e1	.075 BSC		1.90 BSC		
H	.087	.126	2.20	3.20	
L	.004	.024	.10	.60	
α	0°	10°	0°	10°	

Ordering Information

Product Number	Package Type	Order Code
FAN5333A	5-Lead SOT23	FAN5333ASX
FAN5333B	5-Lead SOT23	FAN5333BSX

TRADEMARKS

The following are registered and unregistered trademarks Fairchild Semiconductor owns or is authorized to use and is not intended to be an exhaustive list of all such trademarks.

ACEx™	FAST®	ISOPLANAR™	PowerSaver™	SuperSOT™-8
ActiveArray™	FASTr™	LittleFET™	PowerTrench®	SyncFET™
Bottomless™	FPST™	MICROCOUPLER™	QFET®	TinyLogic®
Build it Now™	FRFET™	MicroFET™	QS™	TINYOPTO™
CoolFET™	GlobalOptoisolator™	MicroPak™	QT Optoelectronics™	TruTranslation™
CROSSVOLT™	GTO™	MICROWIRE™	Quiet Series™	UHC™
DOME™	HiSeC™	MSX™	RapidConfigure™	UltraFET®
EcoSPARK™	I ² C™	MSXPro™	RapidConnect™	UniFET™
E ² CMOS™	i-Lo™	OCX™	μSerDes™	VCX™
EnSigna™	ImpliedDisconnect™	OCXPro™	SILENT SWITCHER®	Wire™
FACT™	IntelliMAX™	OPTOLOGIC®	SMART START™	
FACT Quiet Series™		OPTOPLANAR™	SPM™	
Across the board. Around the world.™		PACMAN™	Stealth™	
The Power Franchise®		POP™	SuperFET™	
Programmable Active Droop™		Power247™	SuperSOT™-3	
		PowerEdge™	SuperSOT™-6	

DISCLAIMER

FAIRCHILD SEMICONDUCTOR RESERVES THE RIGHT TO MAKE CHANGES WITHOUT FURTHER NOTICE TO ANY PRODUCTS HEREIN TO IMPROVE RELIABILITY, FUNCTION OR DESIGN. FAIRCHILD DOES NOT ASSUME ANY LIABILITY ARISING OUT OF THE APPLICATION OR USE OF ANY PRODUCT OR CIRCUIT DESCRIBED HEREIN; NEITHER DOES IT CONVEY ANY LICENSE UNDER ITS PATENT RIGHTS, NOR THE RIGHTS OF OTHERS.

LIFE SUPPORT POLICY

FAIRCHILD'S PRODUCTS ARE NOT AUTHORIZED FOR USE AS CRITICAL COMPONENTS IN LIFE SUPPORT DEVICES OR SYSTEMS WITHOUT THE EXPRESS WRITTEN APPROVAL OF FAIRCHILD SEMICONDUCTOR CORPORATION. As used herein:

1. Life support devices or systems are devices or systems which, (a) are intended for surgical implant into the body, or (b) support or sustain life, or (c) whose failure to perform when properly used in accordance with instructions for use provided in the labeling, can be reasonably expected to result in significant injury to the user.
2. A critical component is any component of a life support device or system whose failure to perform can be reasonably expected to cause the failure of the life support device or system, or to affect its safety or effectiveness.

PRODUCT STATUS DEFINITIONS

Definition of Terms

Datasheet Identification	Product Status	Definition
Advance Information	Formative or In Design	This datasheet contains the design specifications for product development. Specifications may change in any manner without notice.
Preliminary	First Production	This datasheet contains preliminary data, and supplementary data will be published at a later date. Fairchild Semiconductor reserves the right to make changes at any time without notice in order to improve design.
No Identification Needed	Full Production	This datasheet contains final specifications. Fairchild Semiconductor reserves the right to make changes at any time without notice in order to improve design.
Obsolete	Not In Production	This datasheet contains specifications on a product that has been discontinued by Fairchild semiconductor. The datasheet is printed for reference information only.

Rev. 116

ON Semiconductor and  are trademarks of Semiconductor Components Industries, LLC dba ON Semiconductor or its subsidiaries in the United States and/or other countries. ON Semiconductor owns the rights to a number of patents, trademarks, copyrights, trade secrets, and other intellectual property. A listing of ON Semiconductor's product/patent coverage may be accessed at www.onsemi.com/site/pdf/Patent-Marking.pdf. ON Semiconductor reserves the right to make changes without further notice to any products herein. ON Semiconductor makes no warranty, representation or guarantee regarding the suitability of its products for any particular purpose, nor does ON Semiconductor assume any liability arising out of the application or use of any product or circuit, and specifically disclaims any and all liability, including without limitation special, consequential or incidental damages. Buyer is responsible for its products and applications using ON Semiconductor products, including compliance with all laws, regulations and safety requirements or standards, regardless of any support or applications information provided by ON Semiconductor. "Typical" parameters which may be provided in ON Semiconductor data sheets and/or specifications can and do vary in different applications and actual performance may vary over time. All operating parameters, including "Typicals" must be validated for each customer application by customer's technical experts. ON Semiconductor does not convey any license under its patent rights nor the rights of others. ON Semiconductor products are not designed, intended, or authorized for use as a critical component in life support systems or any FDA Class 3 medical devices or medical devices with a same or similar classification in a foreign jurisdiction or any devices intended for implantation in the human body. Should Buyer purchase or use ON Semiconductor products for any such unintended or unauthorized application, Buyer shall indemnify and hold ON Semiconductor and its officers, employees, subsidiaries, affiliates, and distributors harmless against all claims, costs, damages, and expenses, and reasonable attorney fees arising out of, directly or indirectly, any claim of personal injury or death associated with such unintended or unauthorized use, even if such claim alleges that ON Semiconductor was negligent regarding the design or manufacture of the part. ON Semiconductor is an Equal Opportunity/Affirmative Action Employer. This literature is subject to all applicable copyright laws and is not for resale in any manner.

PUBLICATION ORDERING INFORMATION

LITERATURE FULFILLMENT:

Literature Distribution Center for ON Semiconductor
19521 E. 32nd Pkwy, Aurora, Colorado 80011 USA
Phone: 303-675-2175 or 800-344-3860 Toll Free USA/Canada
Fax: 303-675-2176 or 800-344-3867 Toll Free USA/Canada
Email: orderlit@onsemi.com

N. American Technical Support: 800-282-9855 Toll Free
USA/Canada
Europe, Middle East and Africa Technical Support:
Phone: 421 33 790 2910
Japan Customer Focus Center
Phone: 81-3-5817-1050

ON Semiconductor Website: www.onsemi.com
Order Literature: <http://www.onsemi.com/orderlit>
For additional information, please contact your local
Sales Representative

Looking for pricing, stock, or lifecycle information?

Click below to explore more details on WIN SOURCE:

- ⊖ [View FAN5333ASX on WIN SOURCE](#)
- ⊖ [Fairchild/ON Semiconductor Information](#)

Optimize Your Supply Chain with WIN SOURCE Solutions

- ✓ Global Sourcing Solution
- ✓ Obsolete Management
- ✓ Cost Control Management
- ✓ Shortage Management
- ✓ Alternative Solution
- ✓ Excess Inventory Management