



**THE DATASHEET OF  
LME49721MAX/NOPB**



# LME49721 High-Performance, High-Fidelity Rail-to-Rail Input/Output Audio Operational Amplifier

Check for Samples: [LME49721](#)

## FEATURES

- Rail-to-Rail Input and Output
- Easily Drives 10k $\Omega$  Loads to Within 10mV of Each Power Supply Voltage
- Optimized for Superior Audio Signal Fidelity
- Output Short Circuit Protection

## APPLICATIONS

- Ultra High-Quality Portable Audio Amplification
- High-Fidelity Preamplifiers
- High-Fidelity Multimedia
- State-of-the-Art Phono Pre Amps
- High-Performance Professional Audio
- High-Fidelity Equalization and Crossover Networks
- High-Performance Line Drivers
- High-Performance Line Receivers
- High-Fidelity Active Filters
- DAC I–V Converter
- ADC Front-End Signal Conditioning

## KEY SPECIFICATIONS

- Power Supply Voltage Range: 2.2V to 5.5V
- Quiescent Current: 2.15mA (typ)
- THD+N ( $A_V = 2$ ,  $V_{OUT} = 4V_{p-p}$ ,  $f_{IN} = 1\text{kHz}$ )
  - $R_L = 2\text{k}\Omega$ : 0.00008% (typ)
  - $R_L = 600\Omega$ : 0.0001% (typ)
- Input Noise Density: 4nV/ $\sqrt{\text{Hz}}$  (typ), @ 1kHz
- Slew Rate:  $\pm 8.5\text{V}/\mu\text{s}$  (typ)
- Gain Bandwidth Product: 20MHz (typ)
- Open Loop Gain ( $R_L = 600\Omega$ ): 118dB (typ)
- Input Bias Current: 40fA (typ)
- Input Offset Voltage: 0.3mV (typ)
- PSRR: 103dB (typ)

## DESCRIPTION

The LME49721 is a low-distortion, low-noise Rail-to-Rail Input/Output operational amplifier optimized and fully specified for high-performance, high-fidelity applications. Combining advanced leading-edge process technology with state-of-the-art circuit design, the LME49721 Rail-to-Rail Input/Output operational amplifier delivers superior signal amplification for outstanding performance. The LME49721 combines a very high slew rate with low THD+N to easily satisfy demanding applications. To ensure that the most challenging loads are driven without compromise, the LME49721 has a high slew rate of  $\pm 8.5\text{V}/\mu\text{s}$  and an output current capability of  $\pm 9.7\text{mA}$ . Further, dynamic range is maximized by an output stage that drives 10k $\Omega$  loads to within 10mV of either power supply voltage.

The LME49721 has a wide supply range of 2.2V to 5.5V. Over this supply range the LME49721's input circuitry maintains excellent common-mode and power supply rejection, as well as maintaining its low input bias current. The LME49721 is unity gain stable.



Please be aware that an important notice concerning availability, standard warranty, and use in critical applications of Texas Instruments semiconductor products and disclaimers thereto appears at the end of this data sheet.

All trademarks are the property of their respective owners.

## TYPICAL CONNECTION AND PINOUT

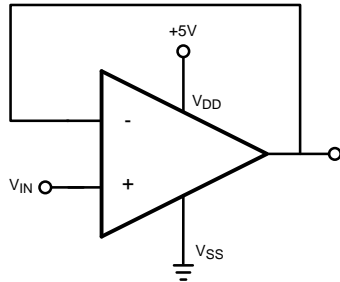

Figure 1. Buffer Amplifier

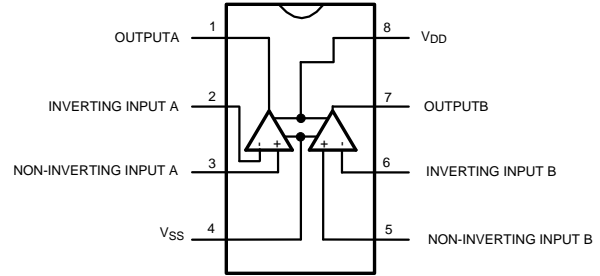

Figure 2. 8-Pin SOIC (D Package)



These devices have limited built-in ESD protection. The leads should be shorted together or the device placed in conductive foam during storage or handling to prevent electrostatic damage to the MOS gates.

### ABSOLUTE MAXIMUM RATINGS<sup>(1)(2)(3)</sup>

Power Supply Voltage ( $V_S = V^+ - V^-$ )	6V
Storage Temperature	-65°C to 150°C
Input Voltage	(V-) - 0.7V to (V+) + 0.7V
Output Short Circuit <sup>(4)</sup>	Continuous
Power Dissipation	Internally Limited
ESD Rating <sup>(5)</sup>	2000V
ESD Rating <sup>(6)</sup>	200V
Junction Temperature	150°C
Thermal Resistance, $\theta_{JA}$ (SOIC)	165°C/W
Temperature Range, $T_{MIN} \leq T_A \leq T_{MAX}$	-40°C $\leq T_A \leq$ 85°C
Supply Voltage Range	2.2V $\leq V_S \leq$ 5.5V

- (1) "Absolute Maximum Ratings" indicate limits beyond which damage to the device may occur, including inoperability and degradation of device reliability and/or performance. Functional operation of the device and/or non-degradation at the Absolute Maximum Ratings or other conditions beyond those indicated in the Recommended Operating Conditions is not implied. The Recommended Operating Conditions indicate conditions at which the device is functional and the device should not be operated beyond such conditions. All voltages are measured with respect to the ground pin, unless otherwise specified.
- (2) The Electrical Characteristics table lists ensured specifications under the listed Recommended Operating Conditions except as otherwise modified or specified by the Electrical Characteristics Conditions and/or Notes. Typical specifications are estimations only and are not ensured.
- (3) If Military/Aerospace specified devices are required, please contact the Texas Instruments Sales Office/Distributors for availability and specifications.
- (4) The maximum power dissipation must be derated at elevated temperatures and is dictated by  $T_{JMAX}$ ,  $\theta_{JA}$ , and the ambient temperature,  $T_A$ . The maximum allowable power dissipation is  $P_{DMAX} = (T_{JMAX} - T_A) / \theta_{JA}$  or the number given in Absolute Maximum Ratings, whichever is lower.
- (5) Human body model, applicable std. JESD22-A114C.
- (6) Machine model, applicable std. JESD22-A115-A.

**ELECTRICAL CHARACTERISTICS FOR THE LME49721**

The following specifications apply for the circuit shown in [Figure 1](#).  $V_S = 5V$ ,  $R_L = 10k\Omega$ ,  $R_{SOURCE} = 10\Omega$ ,  $f_{IN} = 1kHz$ , and  $T_A = 25^\circ C$ , unless otherwise specified.

Symbol	Parameter	Conditions	LME49721		Units (Limits)
			Typical <sup>(1)</sup>	Limit <sup>(2)</sup>	
THD+N	Total Harmonic Distortion + Noise	$A_V = +1$ , $V_{OUT} = 2V_{P-P}$ , $R_L = 2k\Omega$ , $R_L = 600\Omega$	0.0002 0.0002	0.001	% (max)
IMD	Intermodulation Distortion	$A_V = +1$ , $V_{OUT} = 2V_{P-P}$ , Two-tone, 60Hz & 7kHz 4:1	0.0004		%
GBWP	Gain Bandwidth Product		20	15	MHz (min)
SR	Slew Rate	$A_V = +1$	8.5		V/ $\mu s$ (min)
FPBW	Full Power Bandwidth	$V_{OUT} = 1V_{P-P}$ , -3dB referenced to output magnitude at $f = 1kHz$	2.2		MHz
$t_s$	Settling time	$A_V = 1$ , 4V step 0.1% error range	800		ns
$e_n$	Equivalent Input Noise Voltage	$f_{BW} = 20Hz$ to 20kHz, A-weighted	.707	1.13	$\mu V_{P-P}$ (max)
	Equivalent Input Noise Density	$f = 1kHz$ A-weighted	4	6	nV/ $\sqrt{Hz}$ (max)
$I_n$	Current Noise Density	$f = 10kHz$	4.0		fA/ $\sqrt{Hz}$
$V_{OS}$	Offset Voltage		0.3	1.5	mV (max)
$\Delta V_{OS}/\Delta Temp$	Average Input Offset Voltage Drift vs Temperature	$40^\circ C \leq T_A \leq 85^\circ C$	1.1		$\mu V/^\circ C$
PSRR	Average Input Offset Voltage Shift vs Power Supply Voltage		103	85	dB (min)
ISO <sub>CH-CH</sub>	Channel-to-Channel Isolation	$f_{IN} = 1kHz$	117		dB
$I_B$	Input Bias Current	$V_{CM} = V_S/2$	40		fA
$\Delta I_{OS}/\Delta Temp$	Input Bias Current Drift vs Temperature	$-40^\circ C \leq T_A \leq 85^\circ C$	48		fA/ $^\circ C$
$I_{OS}$	Input Offset Current	$V_{CM} = V_S/2$	60		fA
$V_{IN-CM}$	Common-Mode Input Voltage Range			(V+) - 0.1 (V-) + 0.1	V (min)
CMRR	Common-Mode Rejection	$V_{SS} - 100mV < V_{CM} < V_{DD} + 100mV$	93	70	dB (min)
	1/f Corner Frequency		2000		Hz
$A_{VOL}$	Open Loop Voltage Gain	$V_{SS} - 200mV < V_{OUT} < V_{DD} + 200mV$ $R_L = 600\Omega$	118	100	dB (min)
		$R_L = 2k\Omega$	122		dB (min)
		$R_L = 10k\Omega$	130	115	dB (min)
$V_{OUTMIN}$	Output Voltage Swing	$R_L = 600\Omega$	$V_{DD} - 30mV$	$V_{DD} - 80mV$	V (min)
			$V_{SS} + 30mV$	$V_{SS} + 80mV$	V (min)
		$R_L = 10k\Omega$ , $V_S = 5.0V$	$V_{DD} - 10mV$	$V_{DD} - 20mV$	V (min)
			$V_{SS} + 10mV$	$V_{SS} + 20mV$	V (min)
$I_{OUT}$	Output Current	$R_L = 250\Omega$ , $V_S = 5.0V$	9.7	9.3	mA (min)
$I_{OUT-SC}$	Short Circuit Current		100		mA
$R_{OUT}$	Output Impedance	$f_{IN} = 10kHz$ Closed-Loop	0.01		$\Omega$
		Open-Loop	46		
$I_S$	Quiescent Current per Amplifier	$I_{OUT} = 0mA$	2.15	3.25	mA (max)

(1) Typical values represent most likely parametric norms at  $T_A = +25^\circ C$ , and at the Recommended Operation Conditions at the time of product characterization and are not ensured.

(2) Datasheet min/max specification limits are ensured by test or statistical analysis.

### TYPICAL PERFORMANCE CHARACTERISTICS

Graphs were taken in dual supply configuration.

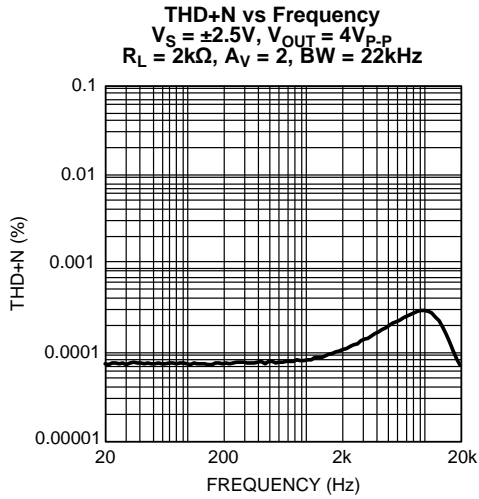

Figure 3.

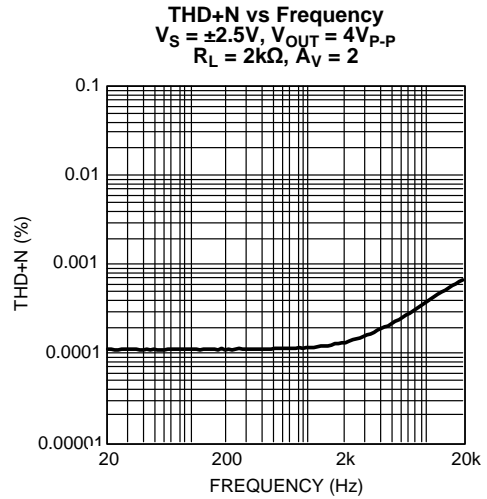

Figure 4.

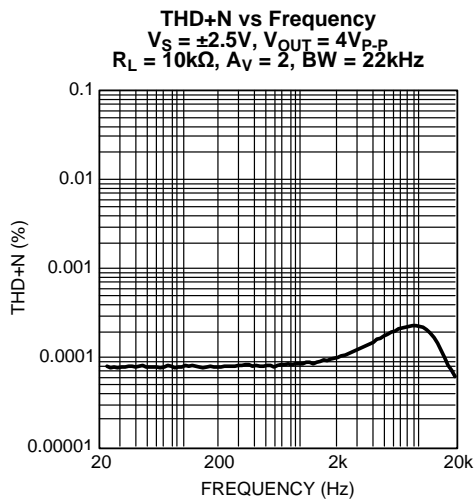

Figure 5.

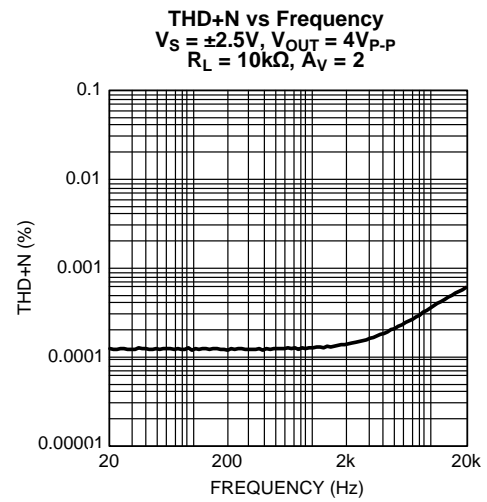

Figure 6.

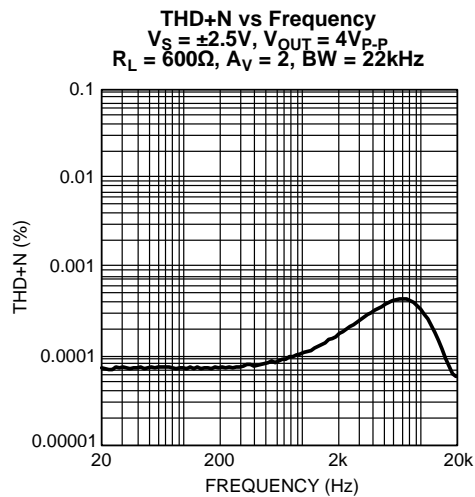

Figure 7.

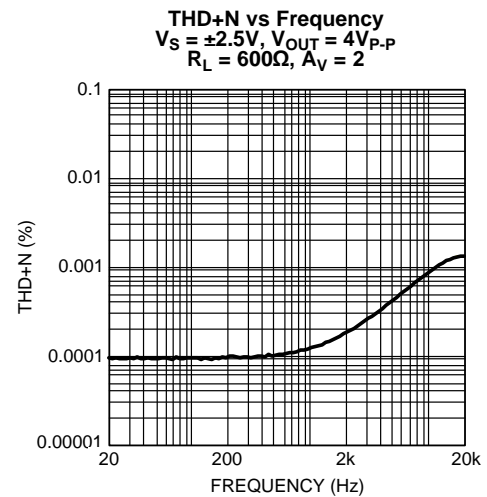

Figure 8.

**TYPICAL PERFORMANCE CHARACTERISTICS (continued)**

Graphs were taken in dual supply configuration.

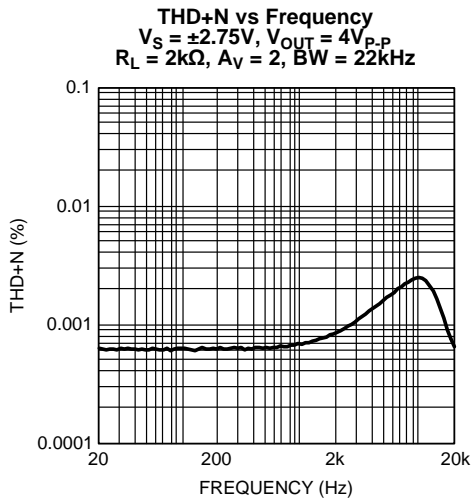

Figure 9.

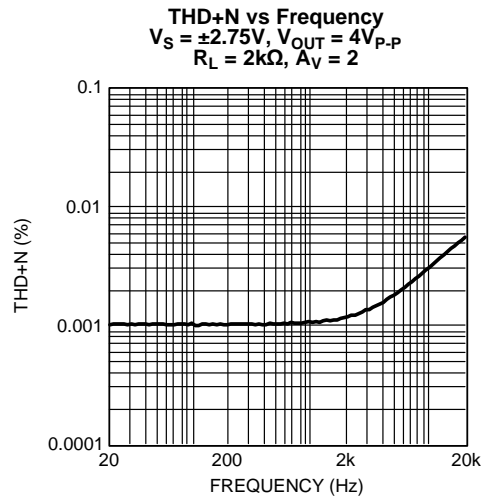

Figure 10.

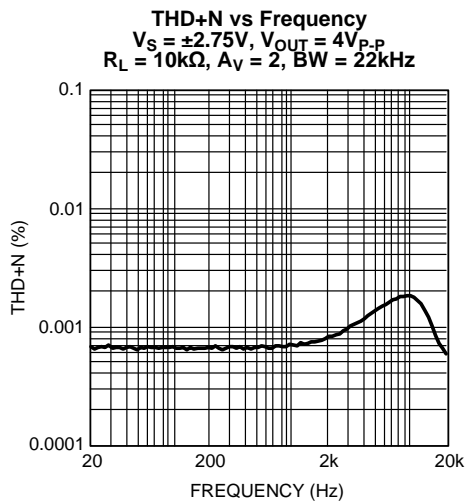

Figure 11.

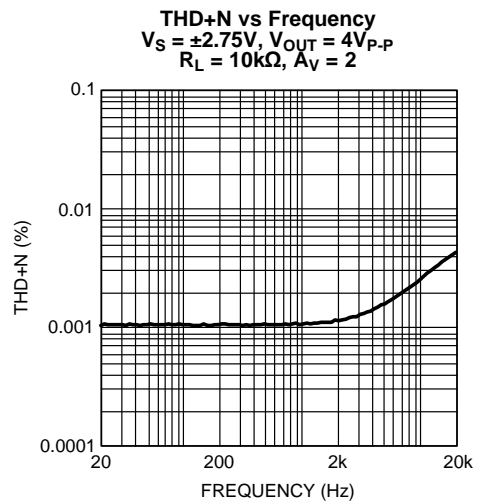

Figure 12.

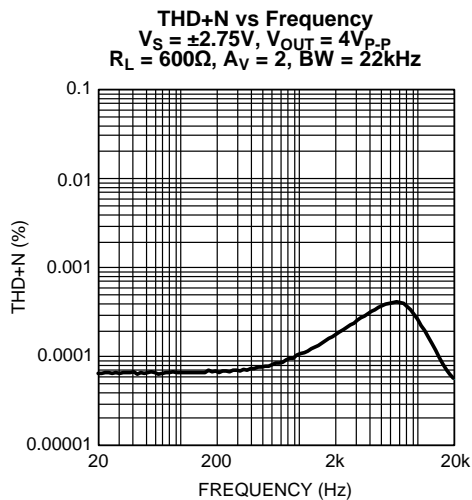

Figure 13.

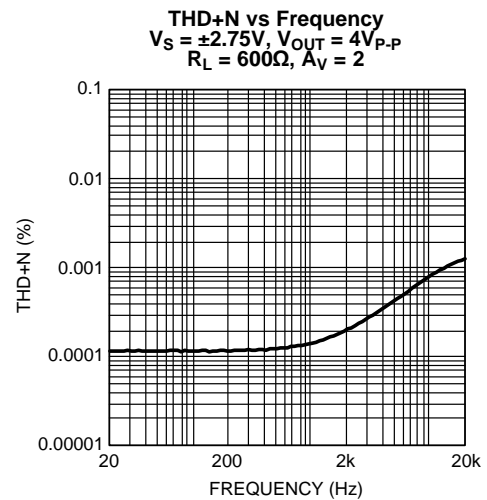

Figure 14.

**TYPICAL PERFORMANCE CHARACTERISTICS (continued)**

Graphs were taken in dual supply configuration.

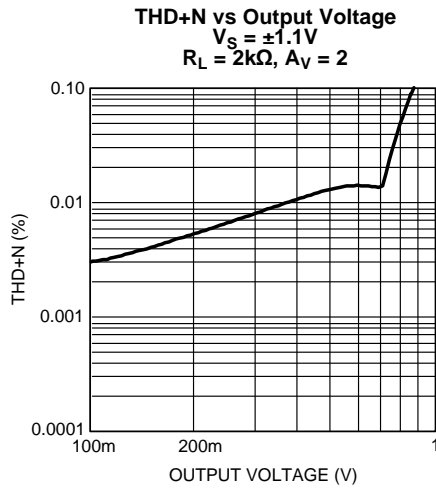

Figure 15.

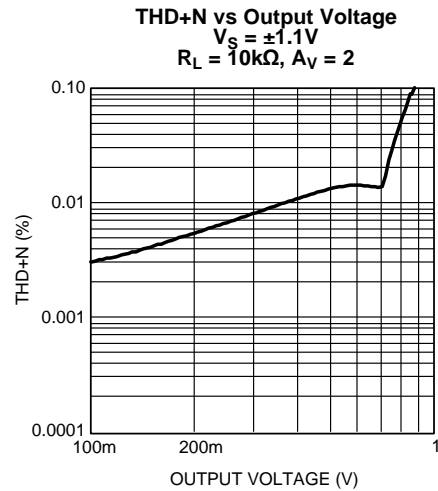

Figure 16.

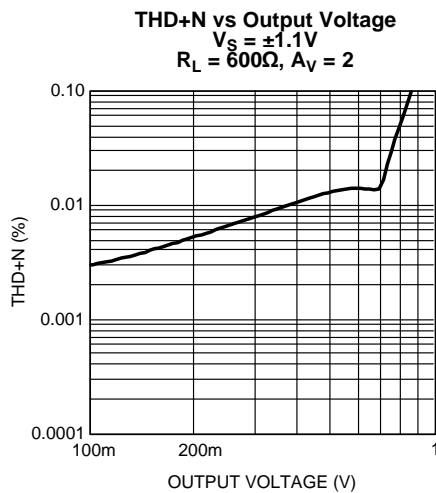

Figure 17.

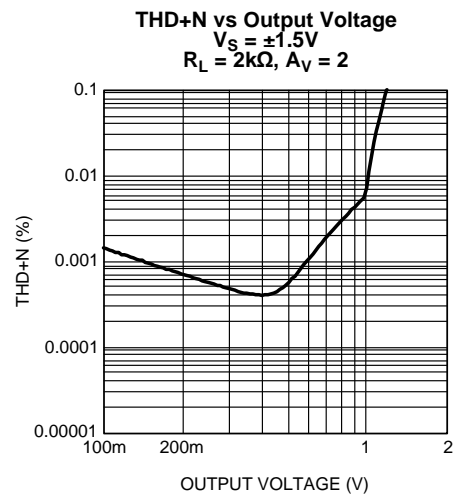

Figure 18.

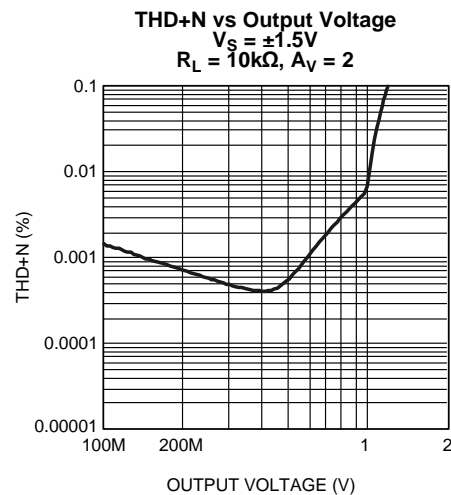

Figure 19.

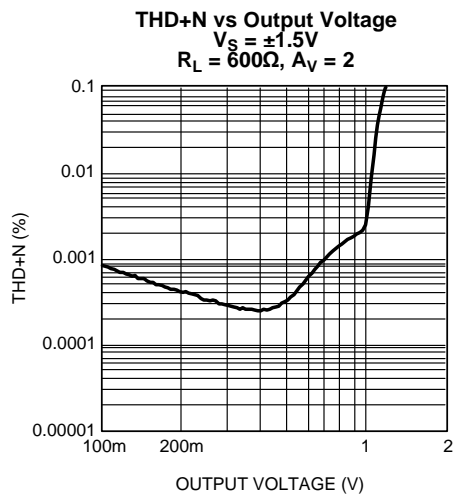
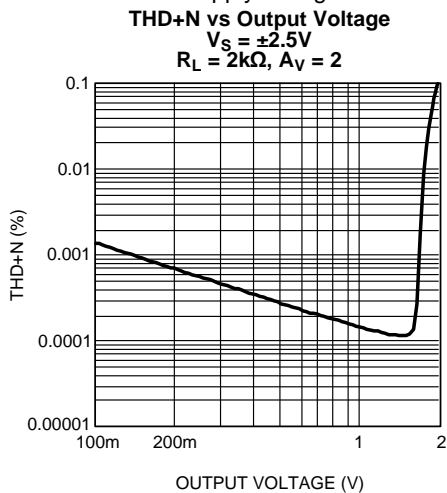

Figure 20.

**TYPICAL PERFORMANCE CHARACTERISTICS (continued)**

Graphs were taken in dual supply configuration.



**Figure 21.**

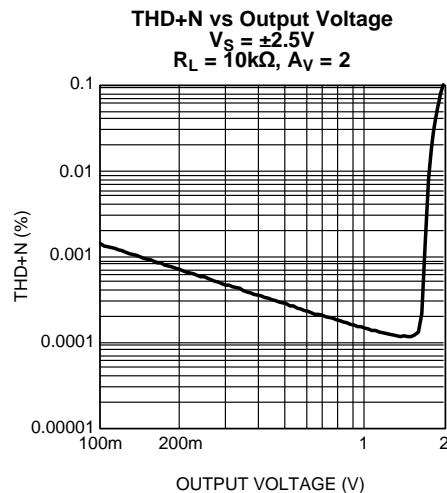

**Figure 22.**

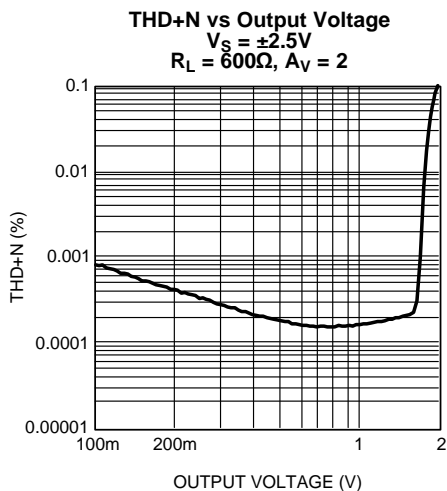

**Figure 23.**

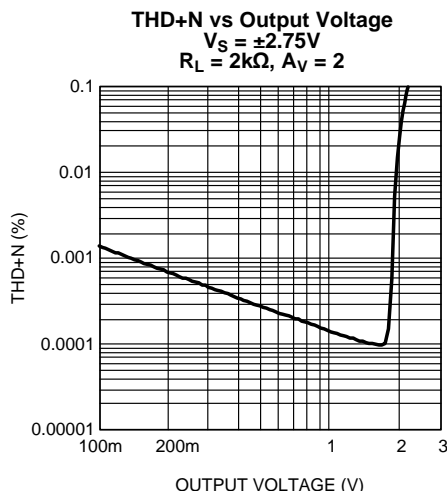

**Figure 24.**

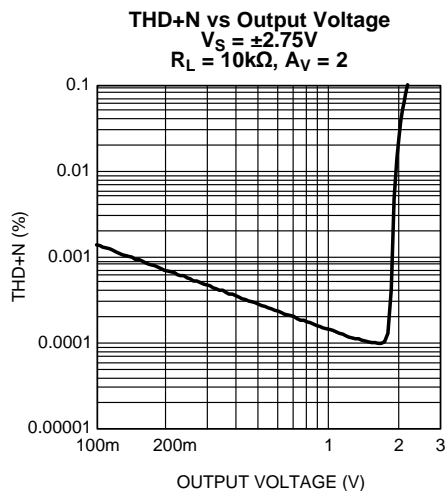

**Figure 25.**

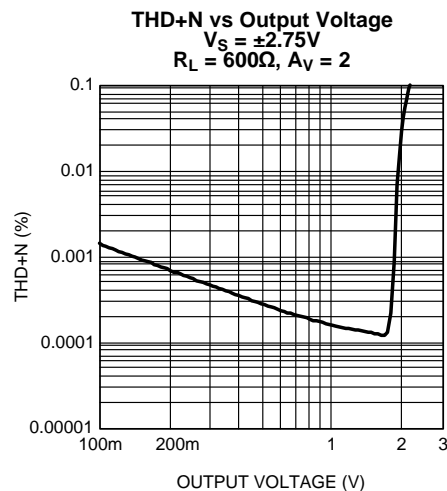

**Figure 26.**

### TYPICAL PERFORMANCE CHARACTERISTICS (continued)

Graphs were taken in dual supply configuration.

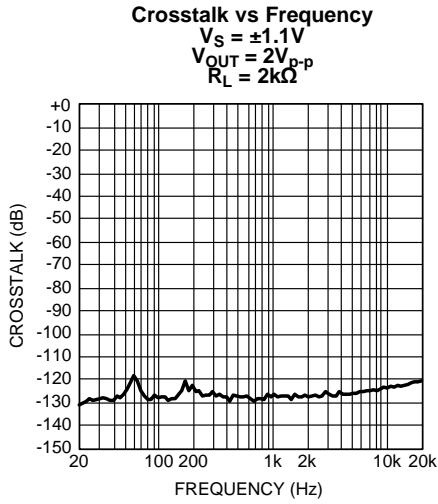

Figure 27.

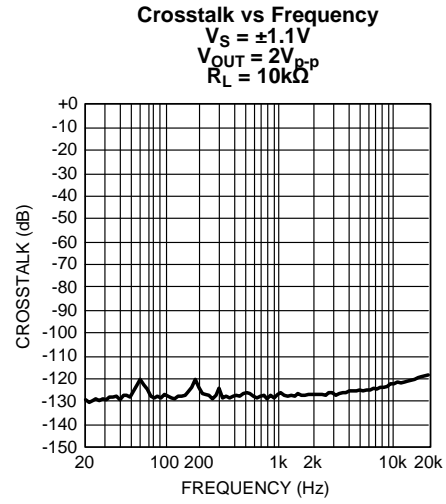

Figure 28.

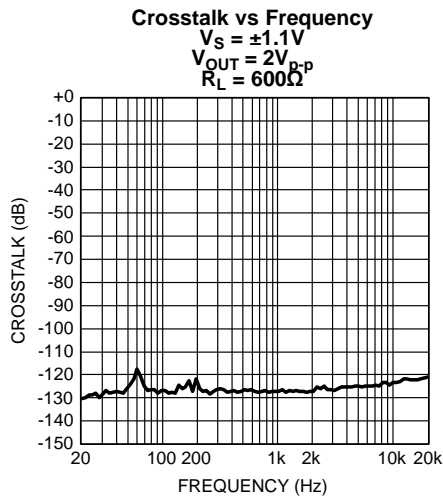

Figure 29.

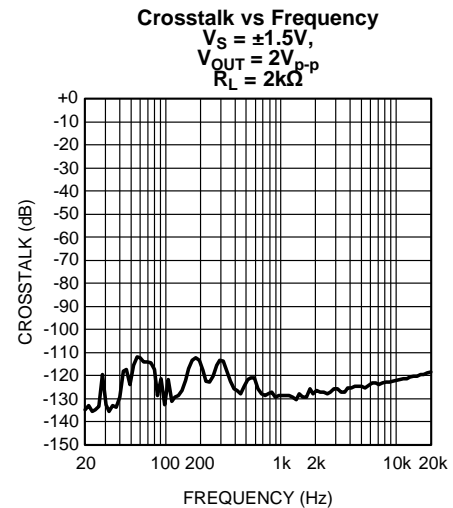

Figure 30.

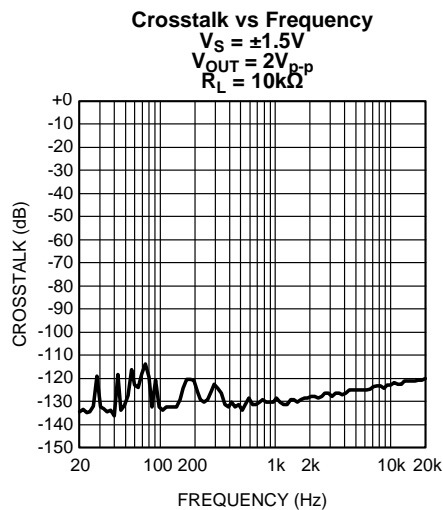

Figure 31.

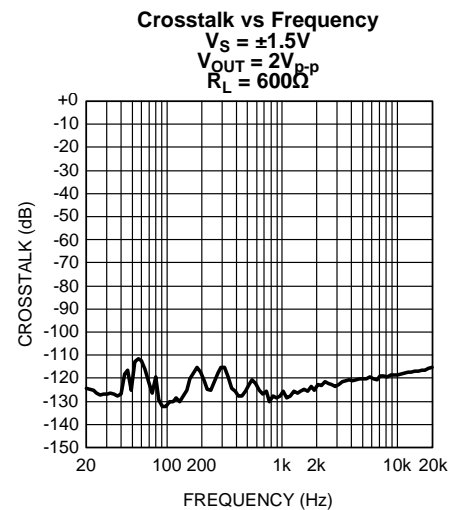

Figure 32.

**TYPICAL PERFORMANCE CHARACTERISTICS (continued)**

Graphs were taken in dual supply configuration.

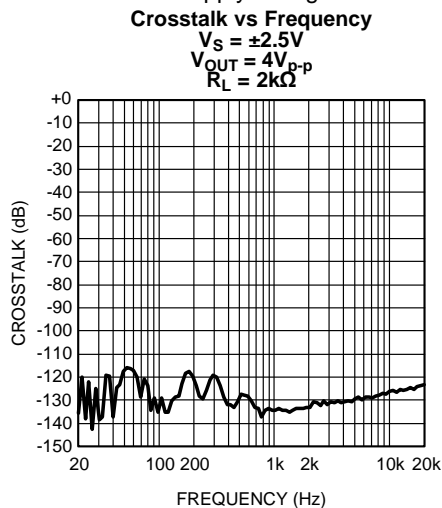

Figure 33.

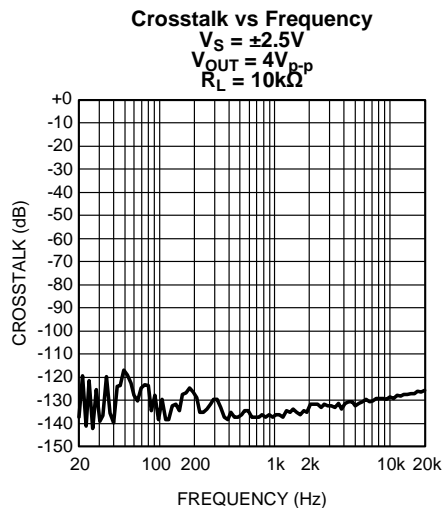

Figure 34.

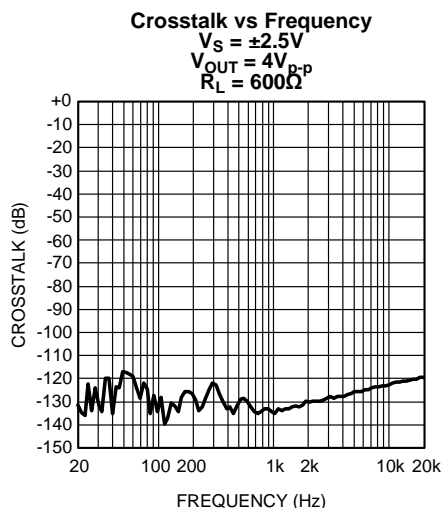

Figure 35.

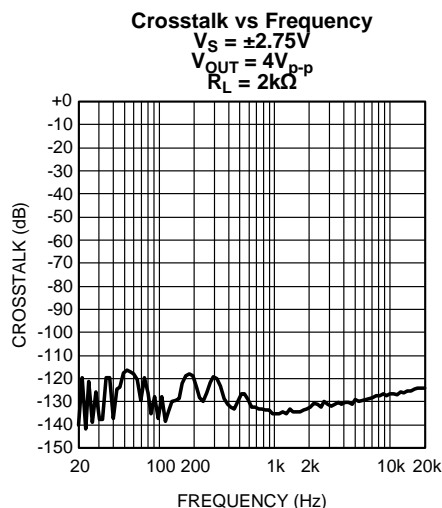

Figure 36.

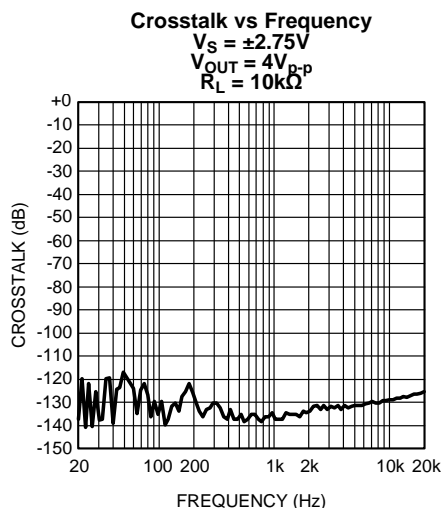

Figure 37.

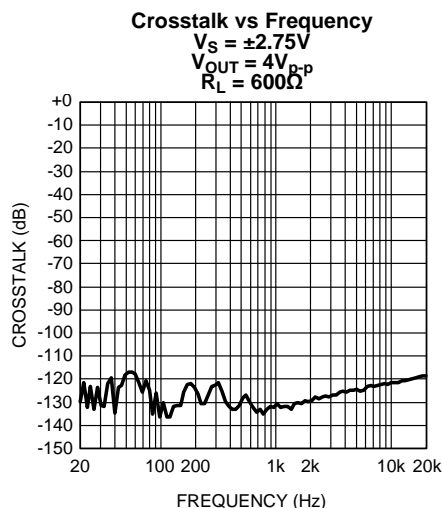
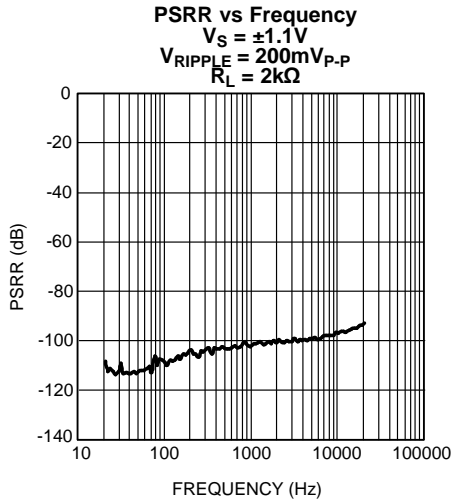

Figure 38.

**TYPICAL PERFORMANCE CHARACTERISTICS (continued)**

Graphs were taken in dual supply configuration.



**Figure 39.**

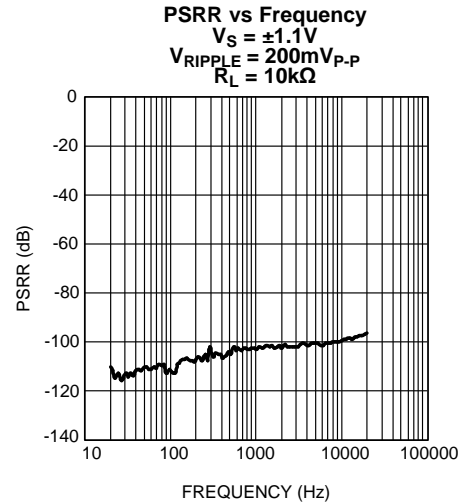

**Figure 40.**

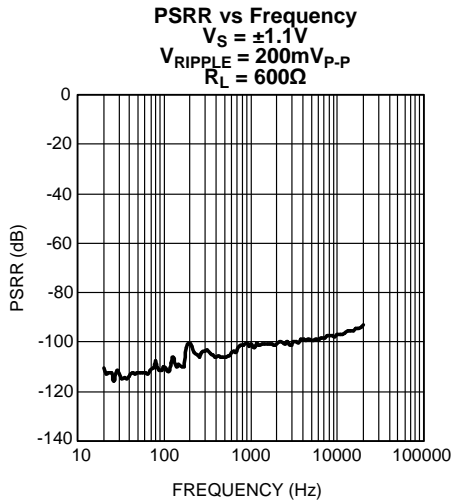

**Figure 41.**

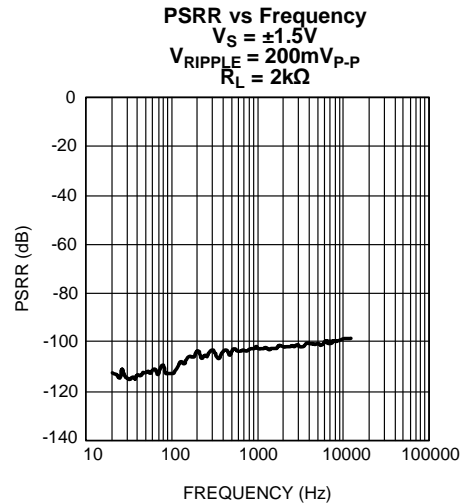

**Figure 42.**

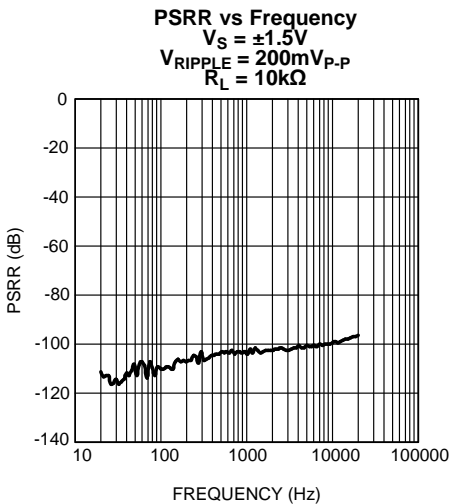

**Figure 43.**

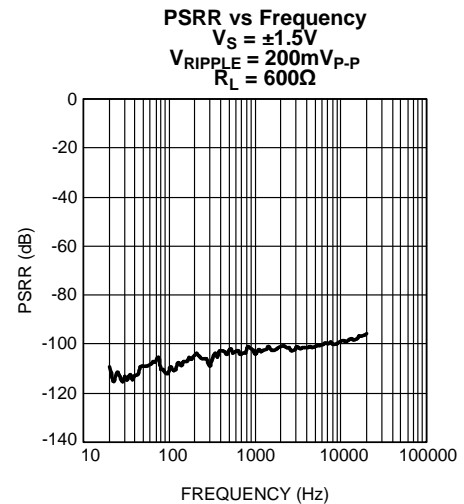

**Figure 44.**

**TYPICAL PERFORMANCE CHARACTERISTICS (continued)**

Graphs were taken in dual supply configuration.

**PSRR vs Frequency**  
 $V_S = \pm 2.5V$   
 $V_{RIPPLE} = 200mV_{P-P}$   
 $R_L = 2k\Omega$

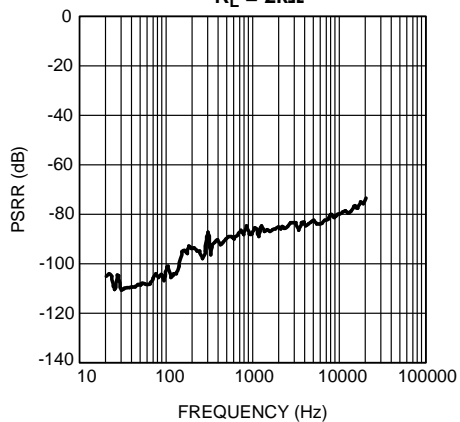

Figure 45.

**PSRR vs Frequency**  
 $V_S = \pm 2.5V$   
 $V_{RIPPLE} = 200mV_{P-P}$   
 $R_L = 10k\Omega$

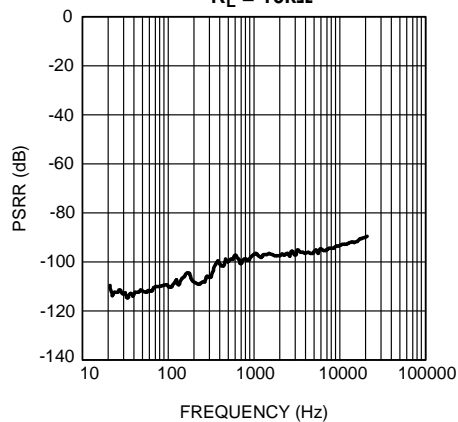

Figure 46.

**PSRR vs Frequency**  
 $V_S = \pm 2.5V$   
 $V_{RIPPLE} = 200mV_{P-P}$   
 $R_L = 600\Omega$

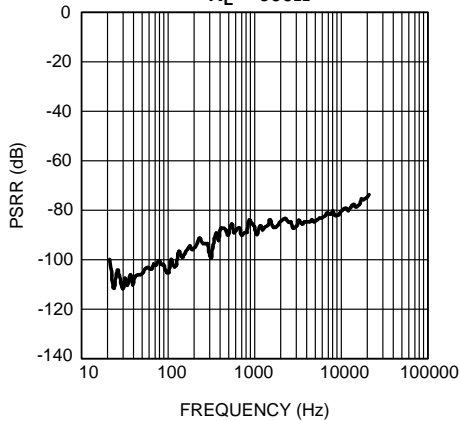

Figure 47.

**PSRR vs Frequency**  
 $V_S = \pm 2.75V$   
 $V_{RIPPLE} = 200mV_{P-P}$   
 $R_L = 2k\Omega$

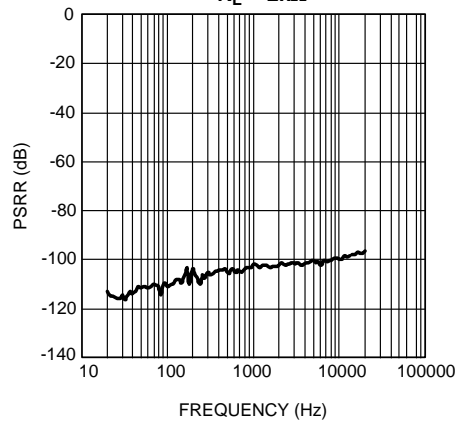

Figure 48.

**PSRR vs Frequency**  
 $V_S = \pm 2.75V$   
 $V_{RIPPLE} = 200mV_{P-P}$   
 $R_L = 10k\Omega$

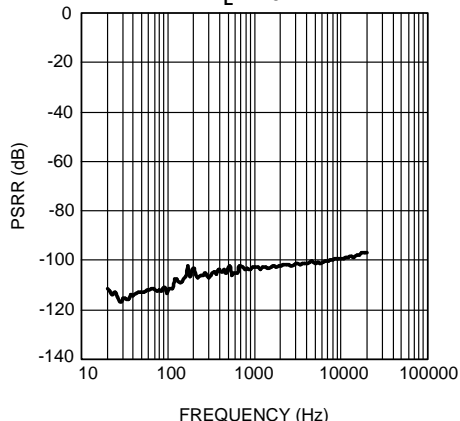

Figure 49.

**PSRR vs Frequency**  
 $V_S = \pm 2.75V$   
 $V_{RIPPLE} = 200mV_{P-P}$   
 $R_L = 600\Omega$

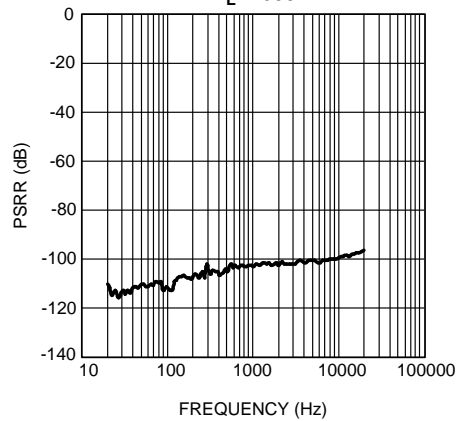

Figure 50.

**TYPICAL PERFORMANCE CHARACTERISTICS (continued)**

Graphs were taken in dual supply configuration.

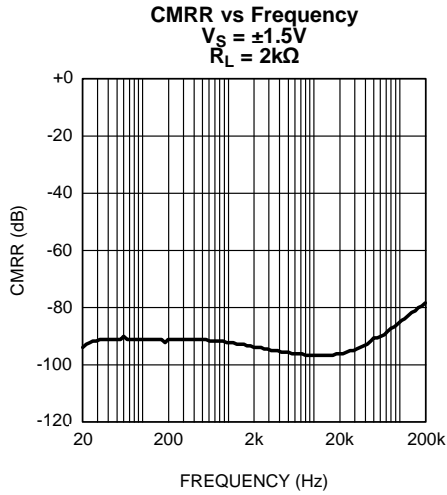

Figure 51.

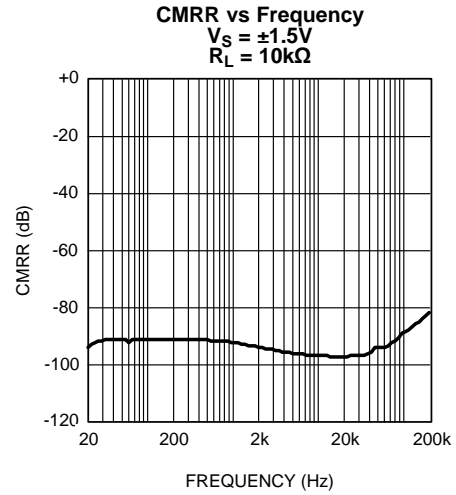

Figure 52.

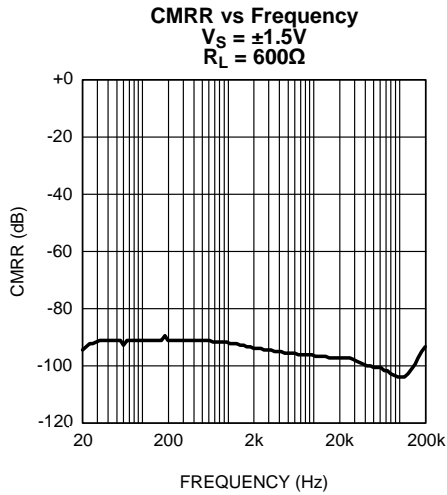

Figure 53.

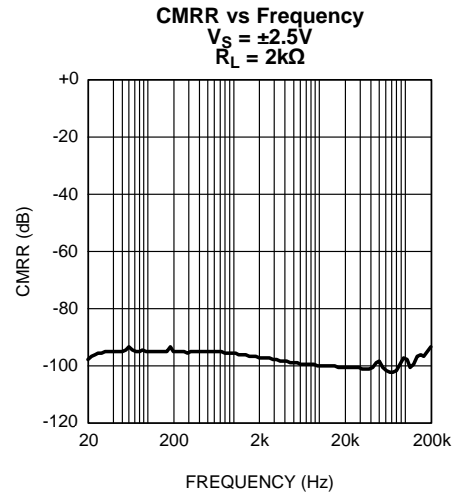

Figure 54.

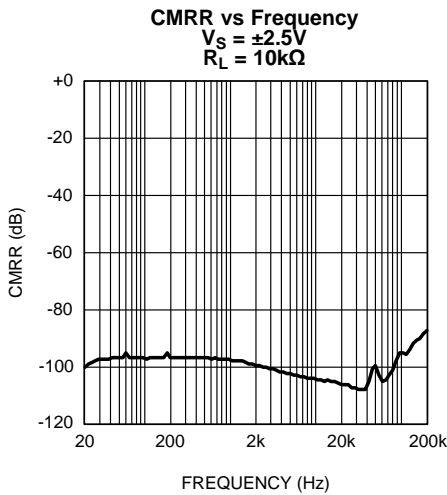

Figure 55.

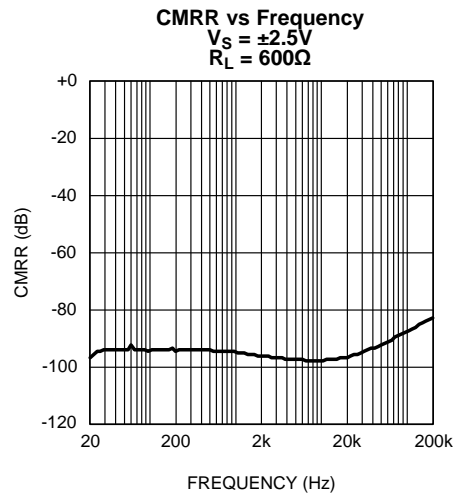

Figure 56.

**TYPICAL PERFORMANCE CHARACTERISTICS (continued)**

Graphs were taken in dual supply configuration.

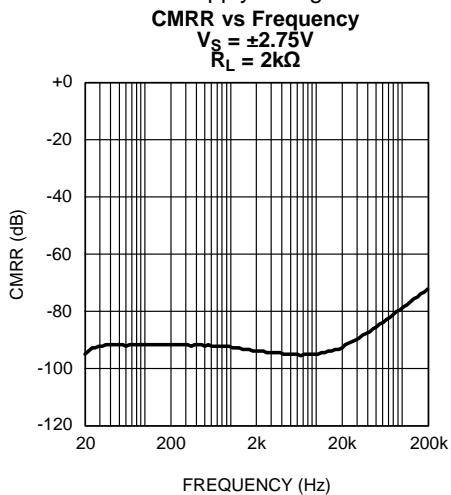

Figure 57.

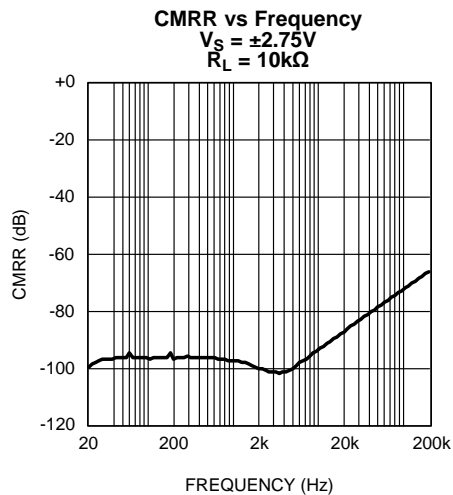

Figure 58.

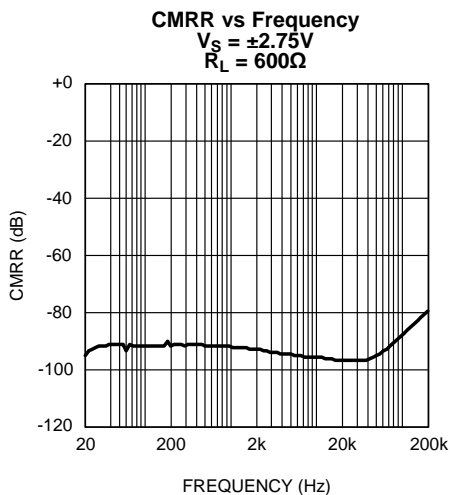

Figure 59.

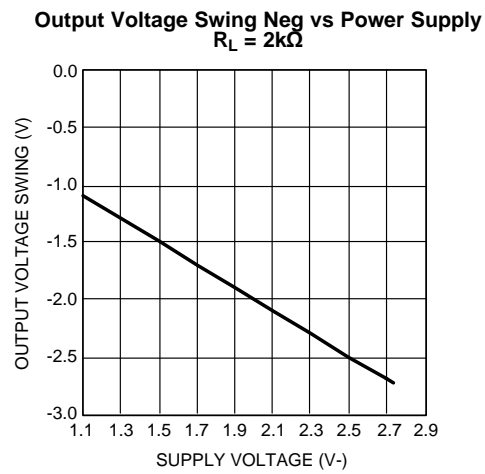

Figure 60.

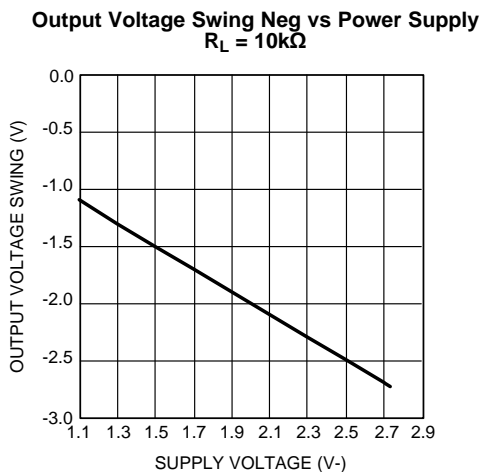

Figure 61.

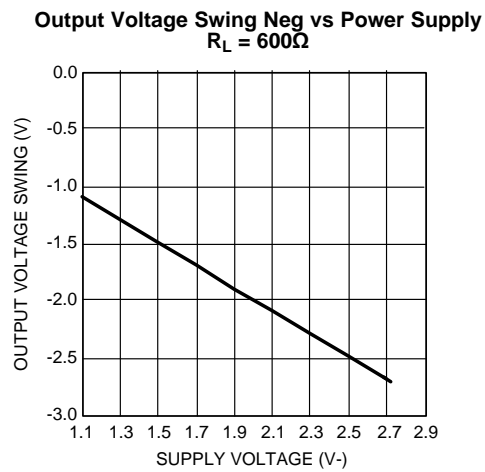

Figure 62.

**TYPICAL PERFORMANCE CHARACTERISTICS (continued)**

Graphs were taken in dual supply configuration.

**Output Voltage Swing Pos vs Power Supply**  
 $R_L = 2k\Omega$

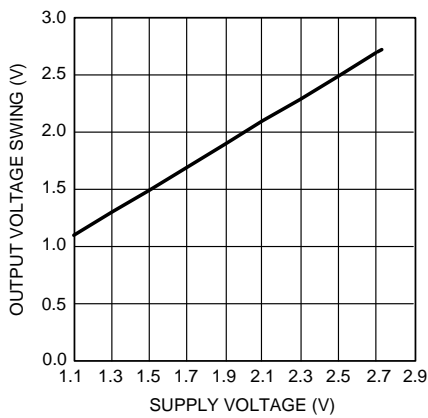

Figure 63.

**Output Voltage Swing Pos vs Power Supply**  
 $R_L = 10k\Omega$

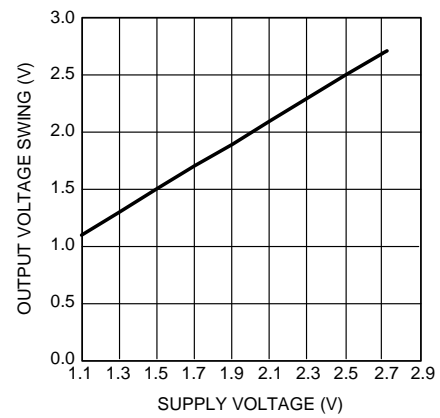

Figure 64.

**Output Voltage Swing Pos vs Power Supply**  
 $R_L = 600\Omega$

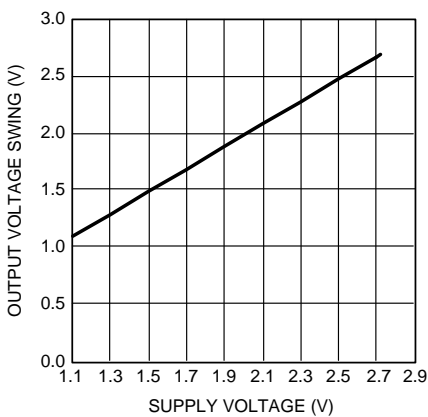

Figure 65.

**Supply Current per amplifier vs Power Supply**  
 $R_L = 2k\Omega$ , Dual Supply

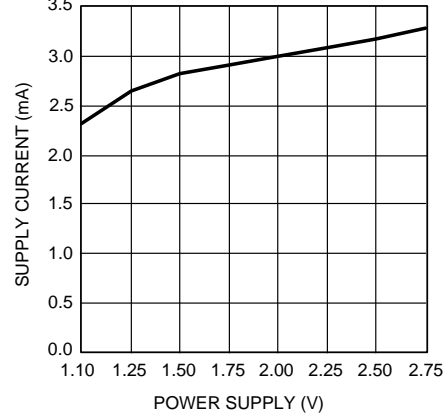

Figure 66.

**Supply Current per amplifier vs Power Supply**  
 $R_L = 10k\Omega$ , Dual Supply

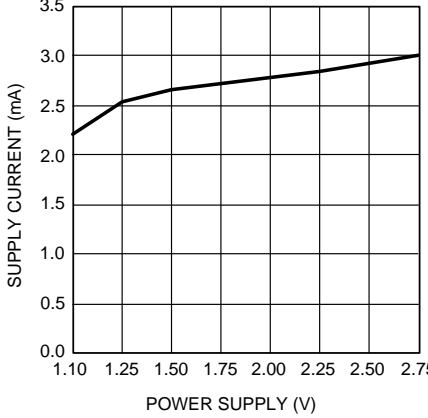

Figure 67.

**Supply Current per amplifier vs Power Supply**  
 $R_L = 600\Omega$ , Dual Supply

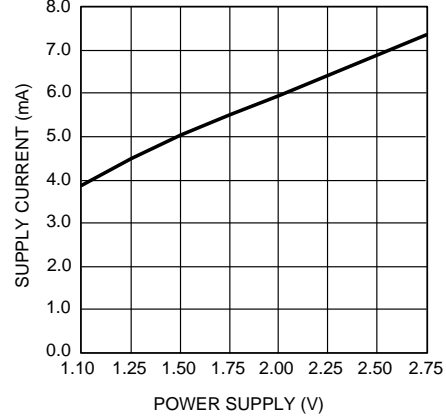

Figure 68.

## APPLICATION INFORMATION

### DISTORTION MEASUREMENTS

The vanishingly low residual distortion produced by LME49721 is below the capabilities of all commercially available equipment. This makes distortion measurements just slightly more difficult than simply connecting a distortion meter to the amplifier's inputs and outputs. The solution, however, is quite simple: an additional resistor. Adding this resistor extends the resolution of the distortion measurement equipment.

The LME49721's low residual is an input referred internal error. As shown in Figure 69, adding the 10Ω resistor connected between the amplifier's inverting and non-inverting inputs changes the amplifier's noise gain. The result is that the error signal (distortion) is amplified by a factor of 101. Although the amplifier's closed-loop gain is unaltered, the feedback available to correct distortion errors is reduced by 101. To ensure minimum effects on distortion measurements, keep the value of R1 low as shown in Figure 69.

This technique is verified by duplicating the measurements with high closed-loop gain and/or making the measurements at high frequencies. Doing so, produces distortion components that are within equipment's capabilities. This datasheet's THD+N and IMD values were generated using the above described circuit connected to an Audio Precision System Two Cascade.

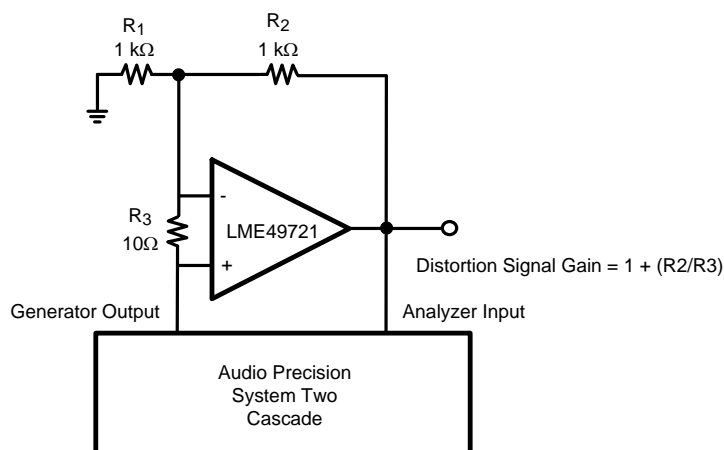

Figure 69. THD+N and IMD Distortion Test Circuit with  $A_v = 2$

### OPERATING RATINGS AND BASIC DESIGN GUIDELINES

The LME49721 has a supply voltage range from +2.2V to +5.5V single supply or  $\pm 1.1$  to  $\pm 2.75$ V dual supply.

Bypassed capacitors for the supplies should be placed as close to the amplifier as possible. This will help minimize any inductance between the power supply and the supply pins. In addition to a 10μF capacitor, a 0.1μF capacitor is also recommended in CMOS amplifiers.

The amplifier's inputs lead lengths should also be as short as possible. If the op amp does not have a bypass capacitor, it may oscillate.

### BASIC AMPLIFIER CONFIGURATIONS

The LME49721 may be operated with either a single supply or dual supplies. Figure 70 shows the typical connection for a single supply inverting amplifier. The output voltage for a single supply amplifier will be centered around the common-mode voltage  $V_{cm}$ . Note: the voltage applied to the  $V_{cm}$  insures the output stays above ground. Typically, the  $V_{cm}$  should be equal to  $V_{DD}/2$ . This is done by putting a resistor divider ckt at this node, see Figure 70.

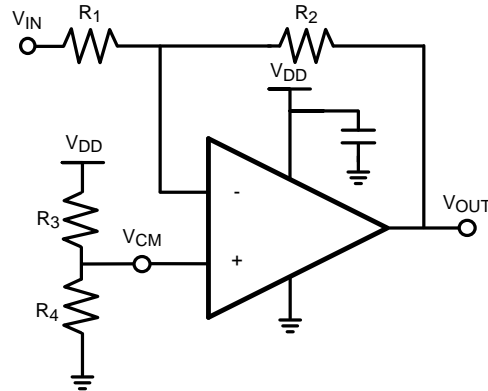

**Figure 70. Single-Supply Inverting Op Amp**

Figure 71 shows the typical connection for a dual supply inverting amplifier. The output voltage is centered on zero.

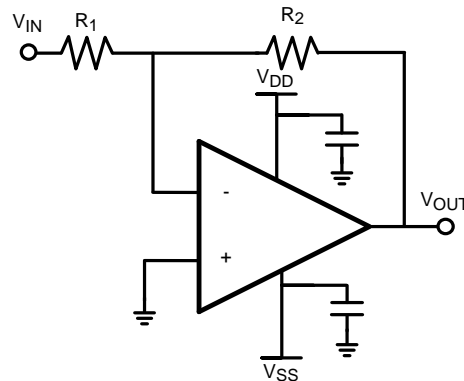

**Figure 71. Dual-Supply Inverting Op Amp**

Figure 72 shows the typical connection for the Buffer Amplifier or also called a Voltage Follower. A Buffer Amplifier can be used to solve impedance matching problems, to reduce power consumption in the source, or to drive heavy loads. The input impedance of the op amp is very high. Therefore, the input of the op amp does not load down the source. The output impedance on the other hand is very low. It allows the load to either supply or absorb energy to a circuit while a secondary voltage source dissipates energy from a circuit. The Buffer is a unity stable amplifier,  $1V/V$ . Although the feedback loop is tied from the output of the amplifier to the inverting input, the gain is still positive. Note: if a positive feedback is used, the amplifier will most likely drive to either rail at the output.

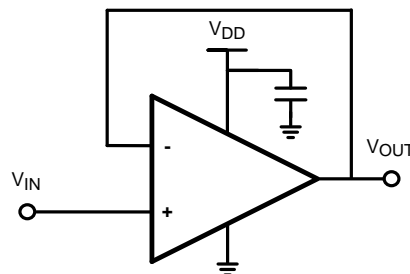

**Figure 72. Buffer**

TYPICAL APPLICATIONS

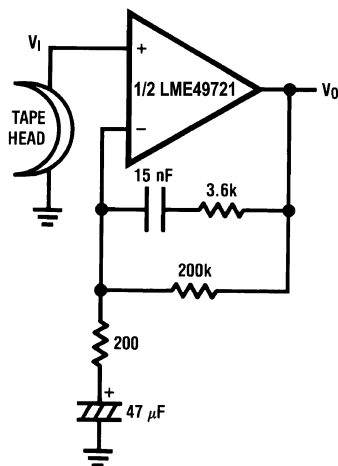

$A_V = 34.5$   
 $F = 1 \text{ kHz}$   
 $E_n = 0.38 \mu\text{V}$   
 A Weighted

Figure 73. ANAB Preamp

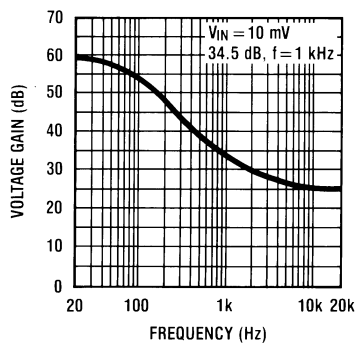
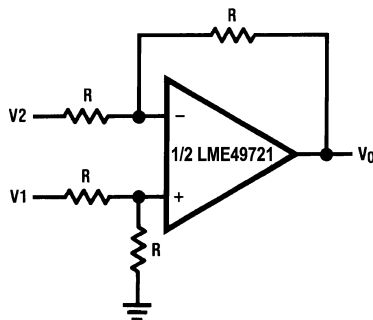
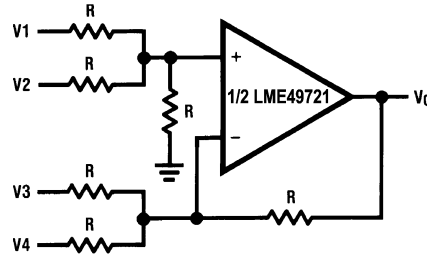

Figure 74. NAB Preamp Voltage Gain vs Frequency



$V_O = V_1 - V_2$

Figure 75. Balanced to Single-Ended Converter



$$V_O = V_1 + V_2 - V_3 - V_4$$

Figure 76. Adder/Subtracter

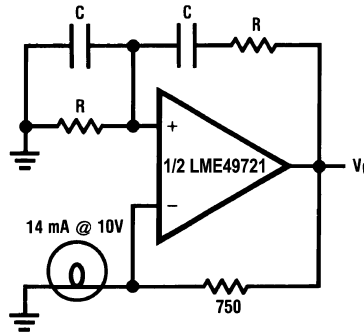

$$f_o = \frac{1}{2\pi RC}$$

Figure 77. Sine Wave Oscillator

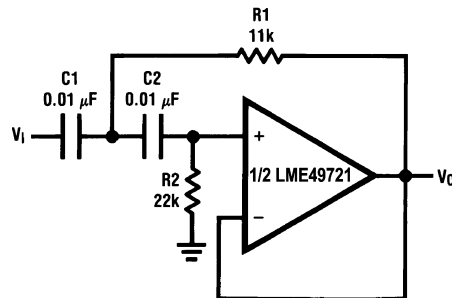

if  $C_1 = C_2 = C$

$$R_1 = \frac{\sqrt{2}}{2\omega_o C}$$

$$R_2 = 2 \cdot R_1$$

Illustration is  $f_o = 1 \text{ kHz}$

Figure 78. Second-Order High-Pass Filter (Butterworth)

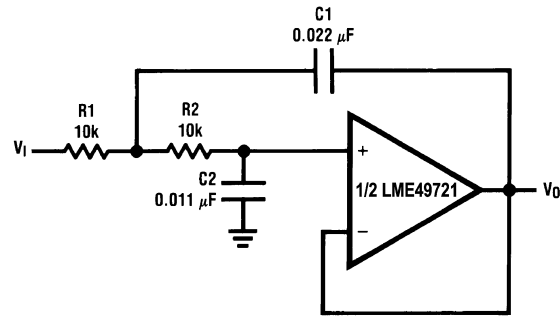

if  $R1 = R2 = R$

$$C1 = \frac{\sqrt{2}}{\omega_0 R}$$

$$C2 = \frac{C1}{2}$$

Illustration is  $f_0 = 1 \text{ kHz}$

Figure 79. Second-Order Low-Pass Filter (Butterworth)

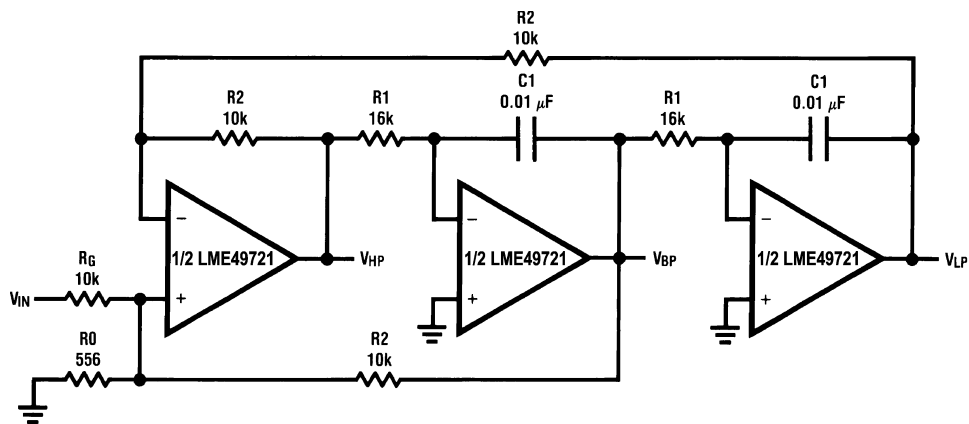

$$f_0 = \frac{1}{2\pi C1 R1}, Q = \frac{1}{2} \left( 1 + \frac{R2}{R0} + \frac{R2}{R1} \right), A_{BP} = Q A_{LP} = Q A_{LH} = \frac{R2}{R0}$$

Illustration is  $f_0 = 1 \text{ kHz}$ ,  $Q = 10$ ,  $A_{BP} = 1$

Figure 80. State Variable Filter

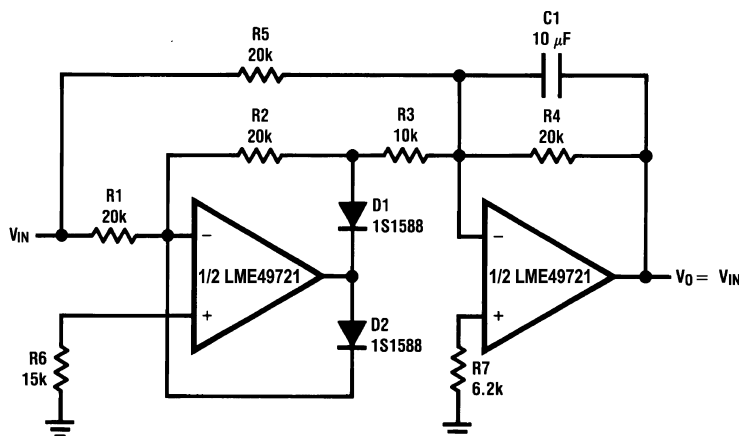

Figure 81. AC/DC Converter

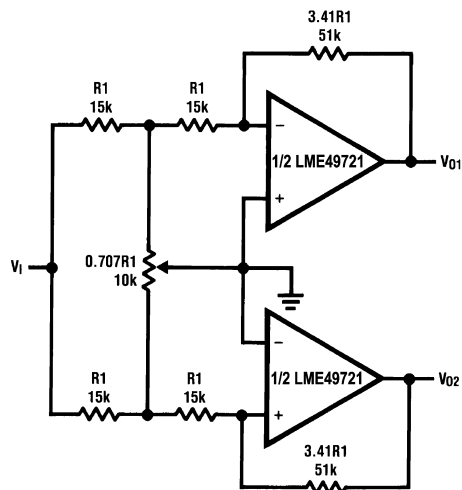

Figure 82. 2-Channel Panning Circuit (Pan Pot)

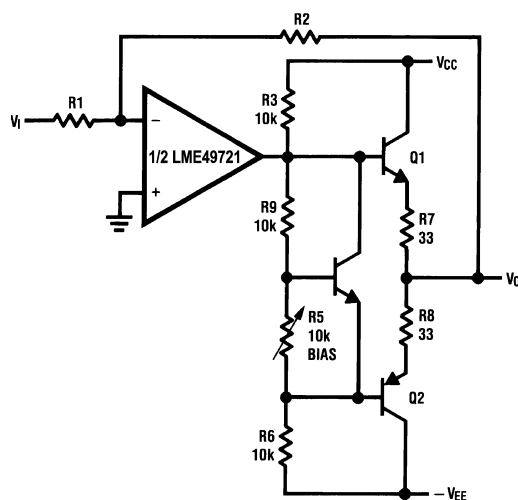
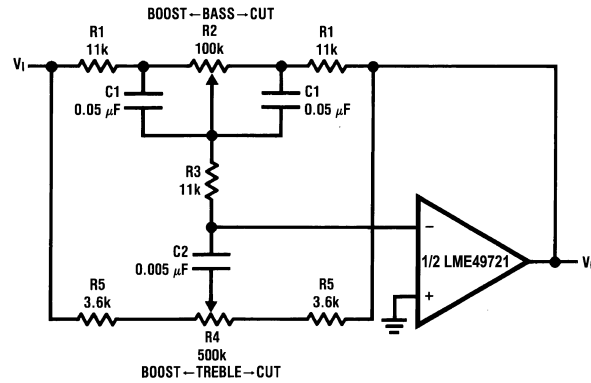

Figure 83. Line Driver



$$f_L = \frac{1}{2\pi R_2 C_1}, f_{LB} = \frac{1}{2\pi R_1 C_1}$$

$$f_H = \frac{1}{2\pi R_5 C_2}, f_{HB} = \frac{1}{2\pi(R_1 + R_5 + 2R_3)C_2}$$

Illustration is:

$$f_L = 32 \text{ Hz}, f_{LB} = 320 \text{ Hz}$$

$$f_H = 11 \text{ kHz}, f_{HB} = 1.1 \text{ kHz}$$

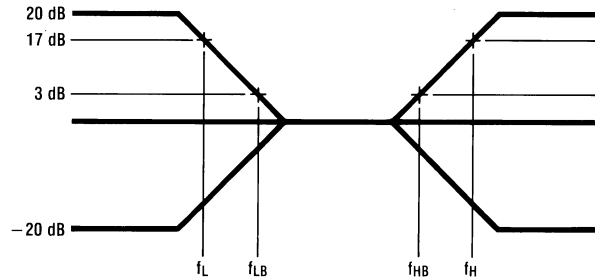
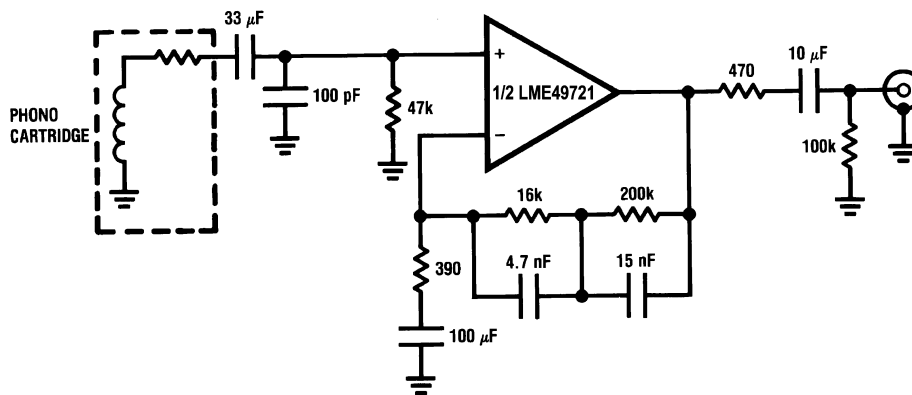
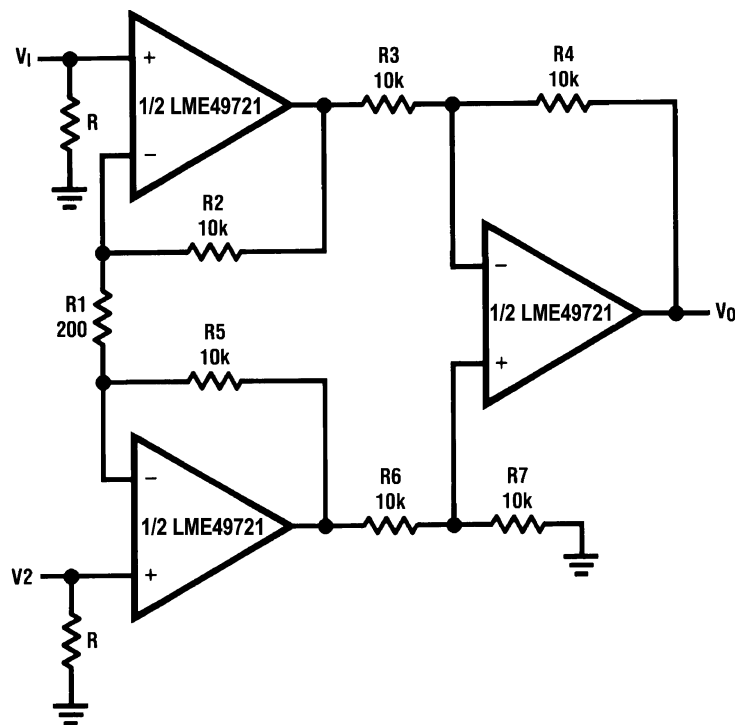

Figure 84. Tone Control



$A_v = 35 \text{ dB}$   
 $E_n = 0.33 \mu\text{V}$   
 $S/N = 90 \text{ dB}$   
 $f = 1 \text{ kHz}$   
 A Weighted  
 A Weighted,  $V_{IN} = 10 \text{ mV}$   
 @  $f = 1 \text{ kHz}$

Figure 85. RIAA Preamp



If  $R2 = R5$ ,  $R3 = R6$ ,  $R4 = R7$

$$V_0 = \left(1 + \frac{2R_2}{R_1}\right) \frac{R_4}{R_3} (V_2 - V_1)$$

Illustration is:

$$V_0 = 101(V_2 - V_1)$$

**Figure 86. Balanced Input Mic Amp**

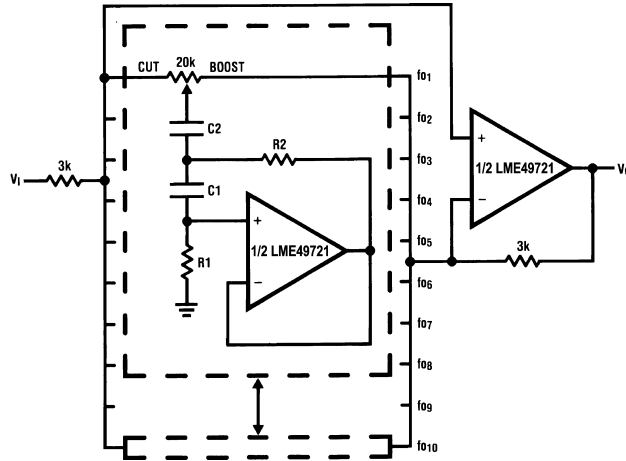

A. See Table 1.

Figure 87. 10-Band Graphic Equalizer

Table 1.  $C_1$ ,  $C_2$ ,  $R_1$ , and  $R_2$  Values for Figure 87<sup>(1)</sup>

$f_o$ (Hz)	$C_1$	$C_2$	$R_1$	$R_2$
32	0.12 $\mu$ F	4.7 $\mu$ F	75k $\Omega$	500 $\Omega$
64	0.056 $\mu$ F	3.3 $\mu$ F	68k $\Omega$	510 $\Omega$
125	0.033 $\mu$ F	1.5 $\mu$ F	62k $\Omega$	510 $\Omega$
250	0.015 $\mu$ F	0.82 $\mu$ F	68k $\Omega$	470 $\Omega$
500	8200pF	0.39 $\mu$ F	62k $\Omega$	470 $\Omega$
1k	3900pF	0.22 $\mu$ F	68k $\Omega$	470 $\Omega$
2k	2000pF	0.1 $\mu$ F	68k $\Omega$	470 $\Omega$
4k	1100pF	0.056 $\mu$ F	62k $\Omega$	470 $\Omega$
8k	510pF	0.022 $\mu$ F	68k $\Omega$	510 $\Omega$
16k	330pF	0.012 $\mu$ F	51k $\Omega$	510 $\Omega$

(1) At volume of change =  $\pm 12$  dB  $Q = 1.7$

**REVISION HISTORY**

<b>Rev</b>	<b>Date</b>	<b>Description</b>
1.0	09/26/07	Initial release.
1.1	10/01/07	Input more info under the Buffer Amplifier.
1.2	04/21/10	Added the Ordering Information table.
C	04/04/13	Changed layout of National Data Sheet to TI format.

**PACKAGING INFORMATION**

Orderable Device	Status (1)	Package Type	Package Drawing	Pins	Package Qty	Eco Plan (2)	Lead/Ball Finish (6)	MSL Peak Temp (3)	Op Temp (°C)	Device Marking (4/5)	Samples
LME49721MA/NOPB	ACTIVE	SOIC	D	8	95	Green (RoHS & no Sb/Br)	CU SN	Level-1-260C-UNLIM	-40 to 85	L49721 MA	<a href="#">Samples</a>
LME49721MAX/NOPB	ACTIVE	SOIC	D	8	2500	Green (RoHS & no Sb/Br)	CU SN	Level-1-260C-UNLIM	-40 to 85	L49721 MA	<a href="#">Samples</a>

(1) The marketing status values are defined as follows:

**ACTIVE:** Product device recommended for new designs.

**LIFEBUY:** TI has announced that the device will be discontinued, and a lifetime-buy period is in effect.

**NRND:** Not recommended for new designs. Device is in production to support existing customers, but TI does not recommend using this part in a new design.

**PREVIEW:** Device has been announced but is not in production. Samples may or may not be available.

**OBSELETE:** TI has discontinued the production of the device.

(2) Eco Plan - The planned eco-friendly classification: Pb-Free (RoHS), Pb-Free (RoHS Exempt), or Green (RoHS & no Sb/Br) - please check <http://www.ti.com/productcontent> for the latest availability information and additional product content details.

**TBD:** The Pb-Free/Green conversion plan has not been defined.

**Pb-Free (RoHS):** TI's terms "Lead-Free" or "Pb-Free" mean semiconductor products that are compatible with the current RoHS requirements for all 6 substances, including the requirement that lead not exceed 0.1% by weight in homogeneous materials. Where designed to be soldered at high temperatures, TI Pb-Free products are suitable for use in specified lead-free processes.

**Pb-Free (RoHS Exempt):** This component has a RoHS exemption for either 1) lead-based flip-chip solder bumps used between the die and package, or 2) lead-based die adhesive used between the die and leadframe. The component is otherwise considered Pb-Free (RoHS compatible) as defined above.

**Green (RoHS & no Sb/Br):** TI defines "Green" to mean Pb-Free (RoHS compatible), and free of Bromine (Br) and Antimony (Sb) based flame retardants (Br or Sb do not exceed 0.1% by weight in homogeneous material)

(3) MSL, Peak Temp. - The Moisture Sensitivity Level rating according to the JEDEC industry standard classifications, and peak solder temperature.

(4) There may be additional marking, which relates to the logo, the lot trace code information, or the environmental category on the device.

(5) Multiple Device Markings will be inside parentheses. Only one Device Marking contained in parentheses and separated by a "~" will appear on a device. If a line is indented then it is a continuation of the previous line and the two combined represent the entire Device Marking for that device.

(6) Lead/Ball Finish - Orderable Devices may have multiple material finish options. Finish options are separated by a vertical ruled line. Lead/Ball Finish values may wrap to two lines if the finish value exceeds the maximum column width.

**Important Information and Disclaimer:** The information provided on this page represents TI's knowledge and belief as of the date that it is provided. TI bases its knowledge and belief on information provided by third parties, and makes no representation or warranty as to the accuracy of such information. Efforts are underway to better integrate information from third parties. TI has taken and continues to take reasonable steps to provide representative and accurate information but may not have conducted destructive testing or chemical analysis on incoming materials and chemicals. TI and TI suppliers consider certain information to be proprietary, and thus CAS numbers and other limited information may not be available for release.

In no event shall TI's liability arising out of such information exceed the total purchase price of the TI part(s) at issue in this document sold by TI to Customer on an annual basis.

## TAPE AND REEL INFORMATION



### QUADRANT ASSIGNMENTS FOR PIN 1 ORIENTATION IN TAPE



\*All dimensions are nominal

Device	Package Type	Package Drawing	Pins	SPQ	Reel Diameter (mm)	Reel Width W1 (mm)	A0 (mm)	B0 (mm)	K0 (mm)	P1 (mm)	W (mm)	Pin1 Quadrant
LME49721MAX/NOPB	SOIC	D	8	2500	330.0	12.4	6.5	5.4	2.0	8.0	12.0	Q1

**TAPE AND REEL BOX DIMENSIONS**



\*All dimensions are nominal

Device	Package Type	Package Drawing	Pins	SPQ	Length (mm)	Width (mm)	Height (mm)
LME49721MAX/NOPB	SOIC	D	8	2500	367.0	367.0	35.0



D0008A

# PACKAGE OUTLINE

SOIC - 1.75 mm max height

SMALL OUTLINE INTEGRATED CIRCUIT



4214825/C 02/2019

### NOTES:

- Linear dimensions are in inches [millimeters]. Dimensions in parenthesis are for reference only. Controlling dimensions are in inches. Dimensioning and tolerancing per ASME Y14.5M.
- This drawing is subject to change without notice.
- This dimension does not include mold flash, protrusions, or gate burrs. Mold flash, protrusions, or gate burrs shall not exceed .006 [0.15] per side.
- This dimension does not include interlead flash.
- Reference JEDEC registration MS-012, variation AA.

# EXAMPLE BOARD LAYOUT

D0008A

SOIC - 1.75 mm max height

SMALL OUTLINE INTEGRATED CIRCUIT



LAND PATTERN EXAMPLE  
EXPOSED METAL SHOWN  
SCALE:8X



SOLDER MASK DETAILS

4214825/C 02/2019

NOTES: (continued)

6. Publication IPC-7351 may have alternate designs.

7. Solder mask tolerances between and around signal pads can vary based on board fabrication site.

# EXAMPLE STENCIL DESIGN

D0008A

SOIC - 1.75 mm max height

SMALL OUTLINE INTEGRATED CIRCUIT



SOLDER PASTE EXAMPLE  
BASED ON .005 INCH [0.125 MM] THICK STENCIL  
SCALE:8X

4214825/C 02/2019

NOTES: (continued)

8. Laser cutting apertures with trapezoidal walls and rounded corners may offer better paste release. IPC-7525 may have alternate design recommendations.
9. Board assembly site may have different recommendations for stencil design.

## IMPORTANT NOTICE AND DISCLAIMER

TI PROVIDES TECHNICAL AND RELIABILITY DATA (INCLUDING DATASHEETS), DESIGN RESOURCES (INCLUDING REFERENCE DESIGNS), APPLICATION OR OTHER DESIGN ADVICE, WEB TOOLS, SAFETY INFORMATION, AND OTHER RESOURCES "AS IS" AND WITH ALL FAULTS, AND DISCLAIMS ALL WARRANTIES, EXPRESS AND IMPLIED, INCLUDING WITHOUT LIMITATION ANY IMPLIED WARRANTIES OF MERCHANTABILITY, FITNESS FOR A PARTICULAR PURPOSE OR NON-INFRINGEMENT OF THIRD PARTY INTELLECTUAL PROPERTY RIGHTS.

These resources are intended for skilled developers designing with TI products. You are solely responsible for (1) selecting the appropriate TI products for your application, (2) designing, validating and testing your application, and (3) ensuring your application meets applicable standards, and any other safety, security, or other requirements. These resources are subject to change without notice. TI grants you permission to use these resources only for development of an application that uses the TI products described in the resource. Other reproduction and display of these resources is prohibited. No license is granted to any other TI intellectual property right or to any third party intellectual property right. TI disclaims responsibility for, and you will fully indemnify TI and its representatives against, any claims, damages, costs, losses, and liabilities arising out of your use of these resources.

TI's products are provided subject to TI's Terms of Sale ([www.ti.com/legal/termsofsale.html](http://www.ti.com/legal/termsofsale.html)) or other applicable terms available either on [ti.com](http://ti.com) or provided in conjunction with such TI products. TI's provision of these resources does not expand or otherwise alter TI's applicable warranties or warranty disclaimers for TI products.

Mailing Address: Texas Instruments, Post Office Box 655303, Dallas, Texas 75265  
Copyright © 2019, Texas Instruments Incorporated

## Looking for pricing, stock, or lifecycle information?

Click below to explore more details on WIN SOURCE:

 [View LME49721MAX/NOPB on WIN SOURCE](#)

 [Texas Instruments](#) Information

## Optimize Your Supply Chain with WIN SOURCE Solutions

-  Global Sourcing Solution
-  Obsolete Management
-  Cost Control Management
-  Shortage Management
-  Alternative Solution
-  Excess Inventory Management