



**THE DATASHEET OF
MSA-0505-TR1G**



Data Sheet

Description

The MSA-0505 is a high performance medium power silicon bipolar Monolithic Microwave Integrated Circuit (MMIC) housed in a low cost, surface mount package. This MMIC is designed for use as a general purpose 50Ω gain block. Typical applications include narrow and broad band IF and RF amplifiers in commercial systems.

The MSA-series is fabricated using Avago's 10 GHz f_T , 25 GHz f_{MAX} , silicon bipolar MMIC process which uses nitride self-alignment, ion implantation, and gold metallization to achieve excellent performance, uniformity and reliability. The use of an external bias resistor for temperature and current stability also allows bias flexibility.

05 Plastic Package

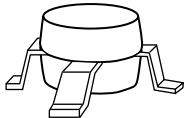

Features

- Cascadable 50 Ω Gain Block
- High Output Power:
18.0 dBm Typical $P_{1\text{ dB}}$ at 1.0 GHz
- Low Distortion:
29.0 dBm Typical IP_3 at 1.0 GHz
- 7.0 dB Typical Gain at 1.0 GHz
- Surface Mount Plastic Package
- Tape-and-Reel Packaging Option Available
- Lead-free Option Available

Typical Biasing Configuration

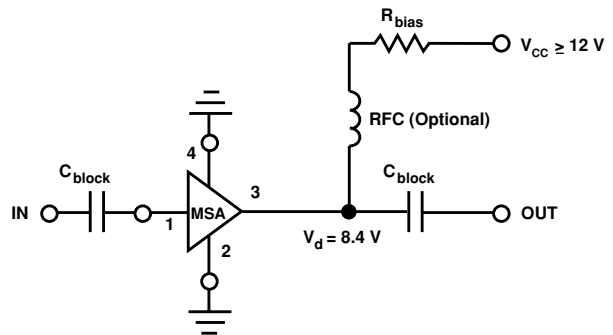

MSA-0505 Absolute Maximum Ratings

Parameter	Absolute Maximum ^[1]
Device Current	135 mA
Power Dissipation ^[2,3]	1.5 W
RF Input Power	+25 dBm
Junction Temperature	200°C
Storage Temperature	-65 to 150°C

Thermal Resistance^[2]:

$$\theta_{jc} = 85^{\circ}\text{C}/\text{W}$$

Notes:

1. Permanent damage may occur if any of these limits are exceeded.
2. $T_{\text{CASE}} = 25^{\circ}\text{C}$.
3. Derate at 11.8 mW/°C for $T_{\text{C}} > 73^{\circ}\text{C}$.

Electrical Specifications^[1], $T_{\text{A}} = 25^{\circ}\text{C}$

Symbol	Parameters and Test Conditions: $I_{\text{d}} = 80 \text{ mA}$, $Z_0 = 50 \Omega$	Units	Min.	Typ.	Max.	
$P_{1 \text{ dB}}$	Output Power at 1 dB Gain Compression	$f = 0.5 \text{ GHz}$			19.0	
		$f = 1.0 \text{ GHz}$		16.0	18.0	
G_{p}	Power Gain ($ S_{21} ^2$)	$f = 0.5 \text{ GHz}$			7.5	
		$f = 1.0 \text{ GHz}$		6.0	7.0	
ΔG_{p}	Gain Flatness	$f = 0.1 \text{ to } 1.5 \text{ GHz}$			± 0.75	
$f_{3 \text{ dB}}$	3 dB Bandwidth ^[2]				2.3	
VSWR	Input VSWR	$f = 0.1 \text{ to } 1.5 \text{ GHz}$			1.6:1	
	Output VSWR	$f = 0.1 \text{ to } 1.5 \text{ GHz}$			2.0:1	
IP_3	Third Order Intercept Point	$f = 1.0 \text{ GHz}$			29.0	
NF	50 Ω Noise Figure	$f = 1.0 \text{ GHz}$			6.5	
t_{D}	Group Delay	$f = 1.0 \text{ GHz}$			190	
V_{d}	Device Voltage		V	6.7	8.4	10.1
dV/dT	Device Voltage Temperature Coefficient		mV/°C		-16.0	

Notes:

1. The recommended operating current range for this device is 60 to 100 mA. Typical performance as a function of current is on the following page.
2. Referenced from 0.1 GHz Gain (GP).

Ordering Information

Part Numbers	No. of Devices	Comments
MSA-0505-STR	10	Bulk
MSA-0505-STRG	100	Bulk
MSA-0505-TR1	500	7" Reel
MSA-0505-TR1G	500	7" Reel

Note: Order part number with a "G" suffix if lead-free option is desired.

MSA-0505 Typical Scattering Parameters ($T_A = 25^\circ\text{C}$, $I_d = 80\text{ mA}$)

Freq. MHz	S_{11}		dB	S_{21}		dB	S_{12}		S_{22}		k
	Mag	Ang		Mag	Ang		Mag	Ang	Mag	Ang	
5	.56	-39	14.9	5.56	161	-18.5	.120	39	.65	-36	0.60
25	.24	-103	9.7	3.05	156	-13.9	.202	12	.25	-90	0.97
50	.15	-130	8.2	2.57	163	-13.7	.207	7	.15	-116	1.15
100	.13	-155	7.8	2.45	165	-13.7	.207	3	.11	-132	1.21
200	.12	-170	7.7	3.43	161	-13.5	.211	1	.11	-145	1.21
400	.12	178	7.5	2.37	148	-13.6	.209	-1	.14	-146	1.23
600	.13	172	7.4	2.34	134	-13.6	.209	-2	.17	-151	1.23
800	.13	168	7.2	2.29	119	-13.6	.209	-3	.21	-157	1.23
1000	.14	166	7.0	2.24	105	-13.4	.213	-4	.25	-164	1.21
1500	.21	159	6.4	2.09	72	-13.3	.217	-6	.34	176	1.16
2000	.30	148	5.2	1.82	42	-13.1	.222	-9	.42	159	1.12
2500	.40	136	4.1	1.60	17	-12.9	.227	-11	.48	146	1.05
3000	.52	121	2.7	1.36	-7	-12.6	.234	-16	.55	133	0.92

Typical Performance, $T_A = 25^\circ\text{C}$

(unless otherwise noted)

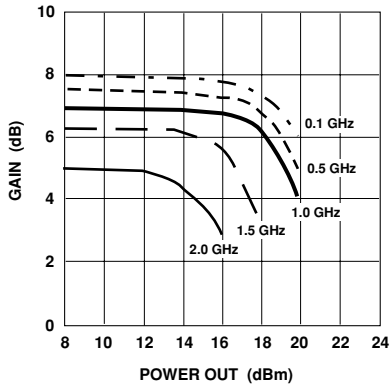

Figure 1. Typical Gain vs. Power Out, $T_A = 25^\circ\text{C}$, $I_d = 80\text{ mA}$.

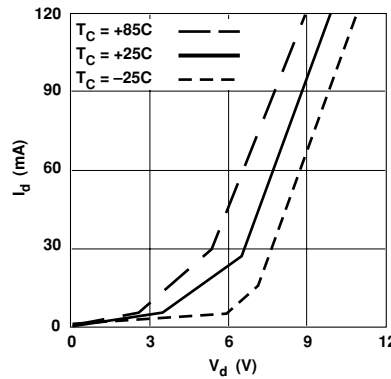

Figure 2. Device Current vs. Voltage.

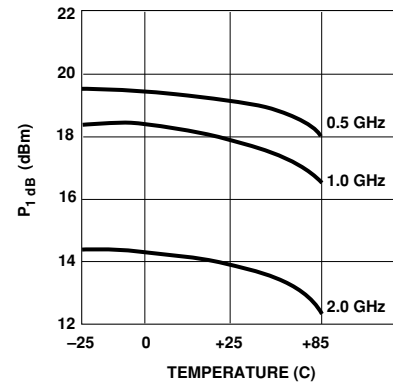

Figure 3. Output Power at 1 dB Gain Compression, vs. Case Temperature, $I_d = 80\text{ mA}$.

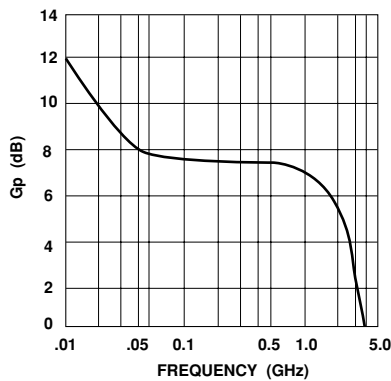

Figure 4. Gain vs. Frequency, $I_d = 80$ to 100 mA .

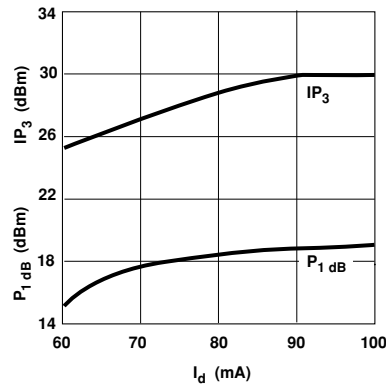



Figure 5. Output Power at 1 dB Gain Compression, Third Order Intercept vs. Case Temperature, $f = 1.0\text{ GHz}$.

Looking for pricing, stock, or lifecycle information?

Click below to explore more details on WIN SOURCE:

-  [View MSA-0505-TR1G on WIN SOURCE](#)
-  [Broadcom Limited Information](#)

Optimize Your Supply Chain with WIN SOURCE Solutions

-  Global Sourcing Solution
-  Obsolete Management
-  Cost Control Management
-  Shortage Management
-  Alternative Solution
-  Excess Inventory Management