

PASSIVE LOW FREQUENCY INTERFACE DEVICE WITH EEPROM AND 134.2 kHz TRANSPONDER INTERFACE

Check for Samples: [TMS37157](#)

FEATURES

- **Wide Supply Voltage Range 2 V to 3.6 V**
- **Ultra Low Power Consumption**
 - Active Mode Max. 150 μ A
 - Power Down Mode 60 nA
- **121 Free Bytes User Memory**
- **Low Frequency Half Duplex (HDX) Interface**
 - HDX Transponder Communication Achieving Maximum Performance and Highest Noise Immunity
 - Special Selective Addressing Mode Allows Anti Collision
 - Up to 8 kbit/s LF Uplink Data Rate
 - 126 Byte EEPROM:
 - 121 Bytes Free Available EEPROM User Memory
 - 32 Bit Unique Serial Number
 - 8 Bit Selective Address
 - High EEPROM Flexibility
 - Pages are Irreversible Lockable and Protectable
 - Battery Check and Battery Charge Function
 - Resonance Frequency: 134.2 kHz
 - Integrated Resonance Frequency Trimming
 - Downlink – Amplitude Shift Keying
 - Uplink – Frequency Shift Keying
- **3 Wire SPI Interface for Accessing the EEPROM and Exchanging Data With the Microcontroller Through the LF Interface**
- **0.6mm Pitch, 4mm x 4mm VQFN Package**

APPLICATIONS

- **Wireless Batteryless Sensor Interface using Energy Harvesting**
 - Microcontroller and Sensor can be Powered Through the LF Link
 - Data is Directly Transmitted Over the LF Link From the Base Station via the TMS37157 to the Microcontroller and Vice Versa.
- **Batteryless Configuration Memory**
 - Memory can be Written Without Battery Support
 - Microcontroller can Read the Content of the Memory When It Gets Connected to a Battery and Use It for Configuration
 - Microcontroller can Write the Memory, Which can be Read Out Later Through the LF Link
- **Ultra Low Power Data Logger Memory (Smart Metering)**
 - Memory Can Be Written By a Microcontroller
 - Memory Can Be Read Through LF Interface Without Battery Support
- **Multi Purpose LF Interface to a Microcontroller**
 - Short Range RF Interface to a Microcontroller Where Other Frequencies are Not an Option
 - Ultra Low Power Mode can Result in an Overall Power Consumption of 60 nA
- **Remote Control Application**
 - Combination With an UHF Transmitter or IR Transmitter and a μ C
 - Power Management of the TMS37157 can Power Down the Microcontroller
 - The Push Button Detection Circuit can Power Up a Microcontroller
- **Stand Alone LF-Transponder with Memory**
 - RFID Transponder with Unique ID and 121 Bytes Free Programmable EEPROM User Memory
 - Only Few Additional Components Needed
 - No Battery Required



Please be aware that an important notice concerning availability, standard warranty, and use in critical applications of Texas Instruments semiconductor products and disclaimers thereto appears at the end of this data sheet.

DESCRIPTION/ORDERING INFORMATION

The TMS37157 combines a Low Frequency Transponder Interface with an SPI Interface and Power Management for a connected microcontroller. It is the ideal device for any Configuration, Data Logger-, Sensor- or Remote Control Application. The Transponder memory is accessible through SPI and LF and, in the second case, operates without the need for a battery. The use of the Low Frequency Band ensures a communication in a defined direction and harsh environments.

The TMS37157 manages the Transponder communication and push button interaction. During sleep state the device enters a special low power mode with only 60 nA current consumption.

The EEPROM memory is accessible over the LF interface without support from the battery or through SPI by a microcontroller if a battery is connected. The TMS37157 offers a special battery charge mode.

The external resonance circuit with a LF coil and a resonance capacitor can be trimmed to the correct resonance frequency with the integrated trimming capability achieving an easy way to eliminate part tolerances.

The small RSA 16-pin package together with only a few external components results in a cost efficient design.

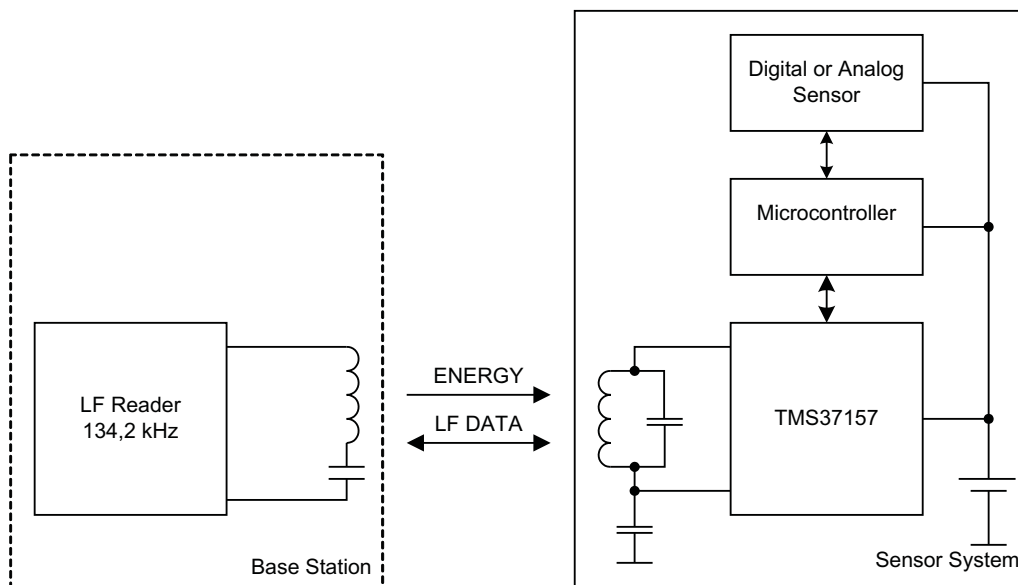

PIN CONFIGURATION

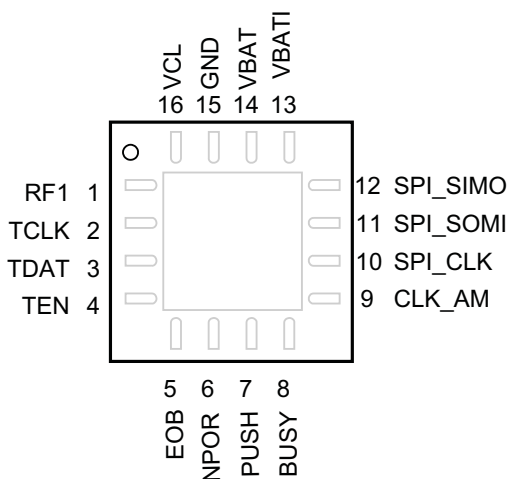

TERMINAL FUNCTIONS

TERMINAL		I/O	DESCRIPTION
NAME	NO.		
RF1	1	I	Antenna
TCLK	2	I	Test interface - clock input. Data is shifted in and out of the TDAT pin on the rising edge of TCLK.
TDAT	3	I/O	Test interface – bidirectional serial data I/O for configuration and trimming.
TEN	4	I	Test interface – enable input.
EOB	5	O	End of burst detector. This signal is high when the RF signal of the base station is OFF.
NPOR	6	O	Active low power-on-reset (open drain) - can be used to reset the microcontroller.
PUSH	7	I	Input of the push button detector – can be used to recognize that a push event has occurred.
BUSY	8	O	Indicates internal control unit activity: <ul style="list-style-type: none"> • During initialization • During transponder operation • During SPI communication (handshaking)
CLKA_M	9	O	This output provides clock signals derived from the external antenna resonance circuit to the microcontroller. This function can be activated by an SPI command. Two frequencies are selectable FRES and FRES/4.
SPI_CLK	10	I	SPI clock input
SPI_SOMI	11	O	SPI data output
SPI_SIMO	12	I	SPI data input
VBATI	13	PWR	Can be used as μ C supply voltage
VBAT	14	PWR	Battery supply
GND	15	PWR	Ground
VCL	16	PWR	Charge capacitor

ORDERING INFORMATION

T _A	PACKAGE ⁽¹⁾ ⁽²⁾		ORDERABLE PART NUMBER	TOPSIDE MARKING
-40°C to 85°C	VQFN – RSA	Reel of 3000	TMS37157IRSARG4	37157I

(1) Package drawings, thermal data, and symbolization are available at www.ti.com/packaging.

(2) For the most current package and ordering information, see the Package Option Addendum at the end of this document, or see the TI website at www.ti.com.

ABSOLUTE MAXIMUM RATINGS⁽¹⁾

over operating free-air temperature range (unless otherwise noted)

		MIN	MAX	UNIT
T_A	Operating free air temperature	-40	85	°C
T_s	Storage temperature ⁽²⁾	-40	125	°C
V_{BAT}	Battery voltage	-0.3	3.6	V
V_{CL}	V_{CL} input voltage		7	V
I_{RF}	Input current ⁽³⁾		10	mA

- (1) Stresses beyond those listed under "absolute maximum ratings" may cause permanent damage to the device. These are stress ratings only, and functional operation of the device at these or any other conditions beyond those indicated under "recommended operating conditions" is not implied. Exposure to absolute-maximum-rated conditions for extended periods may affect device reliability.
- (2) One cycle up to 1000h
- (3) Continuous

OPERATING CONDITIONS

PARAMETER		MIN	TYP	MAX	UNIT
Q_{op}	Operating system quality factor		≥30		
V_{BAT}	Battery voltage	2	3	3.55	V

IC CHARACTERISTICS OVER OPERATING TEMPERATURE RANGE**SUPPLY AND REFERENCE CURRENTS**

PARAMETER		MIN	TYP	MAX	UNIT
I_{VBAT1}	Current out of V_{BAT1}			16	mA
dV_{sw2}	Voltage drop at SW2 ($V_{BAT} - V_{BAT1}$)			100	mV
I_{quiet}	Quiescent current		60	300	nA
I_{active}	Operating current			150	μA
I_{charge}	Battery charge current			2	mA

MODULATION CAPACITOR

PARAMETER		MIN	NOM	MAX	UNIT
CM	Modulation capacitor		110		pF

FRONT END CONTROL

PARAMETER		MIN	NOM	MAX	UNIT
t_{reset}	TMS37157 front-end reset time			14	ms
t_{Hdet}	High bit detection threshold time		$64/f_{TX}$		us

CHARACTERISTICS OF TRANSPONDER SECTION

PARAMETER		MIN	NOM	MAX	UNIT
t_{prebit}	Prebit time		1.9		ms
t_{trans}	High bit transition time of start byte 0x7E		2		ms
t_{high}	High bit time		0.129		ms
t_{low}	Low bit time		0.118		ms
T_{resp}	Response time		12		ms

VCL/VBAT CHECKER

PARAMETER		MIN	NOM	MAX	UNIT
High Level	V_{BAT} checker threshold voltage		2.9		V
Low Level	V_{BAT} checker threshold voltage		2.1		V

VCL/VBAT CHECKER (continued)

PARAMETER		MIN	NOM	MAX	UNIT
V _{charge}	V _{BAT} charge voltage		3.4		V
V _{ch}	V _{CL} checker threshold voltage		3.1		V

TRIMMING CAPACITORS AND SWITCHES

PARAMETER		MIN	NOM	MAX	UNIT
T _{step}	Trimming steps		128		
C _{Tmin}	Minimum trimming capacitor		0		pF
C _{T1}	Trimming capacitor 1		0.6		pF
C _{T2}	Trimming capacitor 2		1.2		pF
C _{T3}	Trimming capacitor 3		2.4		pF
C _{T4}	Trimming capacitor 4		4.7		pF
C _{T5}	Trimming capacitor 5		9.4		pF
C _{T6}	Trimming capacitor 6		18.8		pF
C _{T7}	Trimming capacitor 7		37.6		pF
C _T	Maximum trimming capacitor (C _T = C _{T1} + C _{T2} + ... + C _{T7})	63.5	74.4	85.9	pF

RF LIMITER

PARAMETER		MIN	NOM	MAX	UNIT
V _{RFlim}	RF limiter voltage	10.5	12	14	V
V _{CLim}	Limited V _{CL} voltage Limited V _{CL} voltage is the result of the RF limiter in the application circuit	5.75	5.9	6.5	V

CONTROL AND SPI INTERFACE

PARAMETER		MIN	NOM	MAX	UNIT
	Busy low time See SPI Comm.		30-70		μs
	Busy high time See SPI Comm.		10-30		ms

PARAMETER		MIN	NOM	MAX	UNIT
V _{OL}	Low level output voltage, SPI_SOMI, BUSY V _{BAT} = 2.0...3.6V, R _L = 100 kΩ		0.05 × V _{BAT}	0.07 × V _{BAT}	V
V _{OH}	High level output voltage, SPI_SOMI, BUSY V _{BAT} = 2.0...3.6V, R _L = 100 kΩ	0.93 × V _{BAT}	0.95 × V _{BAT}		V
V _{IL}	Low level input voltage, SPI_SIMO, SPI_CLK V _{BAT} = 2.0...3.6V, R _L = 100 kΩ			0.1 × V _{BAT}	V
V _{IH}	High level input voltage, SPI_SIMO, SPI_CLK V _{BAT} = 2.0...3.6V, R _L = 100 kΩ	0.9 × V _{BAT}		V _{BAT}	V

ACTIVATION LIMIT OF TMS37157

PARAMETER		MIN	NOM	MAX	UNIT
V _{act}	Activation level for transponder response f = 134.2 kHz ⁽¹⁾	5.75	5.9	6.5	V

- (1) At beginning of the response the voltage V_{CL} must be just limited. Only in this case the function is guaranteed if components and I_C parameters are at the limit, see [Figure 1](#). The voltage is measured at V_{CL} just before the Transponder starts with the response protocol. The longest in the application used downlink telegram with maximum number of high bits should be used. The low and high bit response frequency should be at the lowest value which occurs in the application. In case of an additional power phase (Programming) the level has to be after that additional power phase.

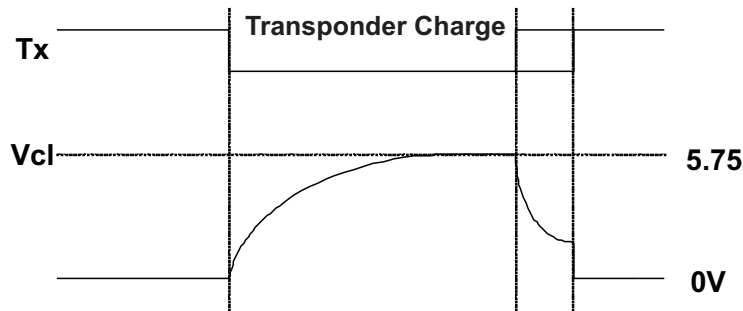

Figure 1. Activation limit of TMS37157

MEMORY

PARAMETER		MIN	TYP	MAX	UNIT
P/E-C	Program/erase cycles	25°C	200000		Cycles
X _{DRET}	Data retention	T _s = 25°C	10		Years

TEST INTERFACE

PARAMETER		MIN	TYP	MAX	UNIT
R _{TCLK}	Pull-down resistor, TCLK	7	10	25	kΩ
R _{TDAT}	Pull-down resistor, TDAT	20	150	375	kΩ
R _{TEN}	Pull-down resistor, TEN	5	10	25	kΩ
V _{OL}	Low level output voltage, TDAT	V _{CL} = 5V, R _L = 2.5 kΩ		0.25	V
V _{OH}	High level output voltage, TDAT	V _{CL} = 5V, R _L = 2.5 kΩ	4.75		V

TRANSPONDER MODE

TRANSPONDER TIMING USING PPM

PARAMETER		MIN	TYP	MAX	UNIT
PPM - Pulse Position Modulation					
t _{offtrp}	Write pulse pause (PPM) ⁽¹⁾		170		μs
t _{ontrpL}	Write pulse activation/ low bit (PPM) ⁽¹⁾		230		μs
t _{ontrpH}	Write pulse activation/ high bit (PPM) ⁽¹⁾		350		μs
t _{bitrpL}	Write low bit period ⁽¹⁾		400		μs
t _{bitrpH}	Write high bit period ^{(1) (2) (3)}	510	520	1730	μs

(1) This timing is measured at the transponder using a pickup coil. This timing is with Low Bit Frequency = 134.7kHz and is influenced by various factors e.g. detuning and coupling to the reader antenna and. Out of this timing the low and high bit are detected by the transponder logic.

(2) Except the last bit this limitation of the duration is valid for all downlink bits.

(3) To detect a High bit the absolute minimum of t_{bitrpH} = 510 μs must be met.

READER RECOMMENDATIONS

PARAMETER		MIN	TYP	MAX	UNIT
QTX, QRX	Reader operating quality factor			10	
f _{TX}	Transmitter frequency	134.16	134.2	134.24	kHz
t _{TX}	Charge time	20	25		ms
t _{TXoff}	Transmitter off time	3			ms
t _{prog}	Programming time	15			ms
t _{RD}	Read time	14.9	15		ms

READER TIMINGS USING PPM

PARAMETER		MIN	TYP	MAX	UNIT
PPM - Pulse Position Modulation					
t_{off}	Off time (PPM) ⁽¹⁾		170		μ s
t_{onL}	Low bit on time (PPM) ⁽¹⁾		230		μ s
t_{bitL}	Low bit duration (PPM) ⁽¹⁾		400		μ s
t_{onH}	High bit on time ⁽¹⁾		350		μ s
t_{bitH}	High bit duration (PPM) ⁽¹⁾		520	1730	μ s

(1) Timing recommendation is only valid for a Reader Operating Quality Factor $Q_{TX} = Q_{RX} \leq 10$.

ANTENNA CURRENTS FOR EQUIVALENT FIELD STRENGTH LEVELS

PARAMETER		MIN	TYP	MAX	UNIT
$I_{short}^{(1)}$	Equivalent current for operation (True RMS)	I_{prog}		4.3	mA

(1) The circuit below is used to determine equivalent short circuit current at the position of the TMS37157 transponder coil. The measured value must be equal or above the specified value in the table above. The operating Q factor Q_{op} depends on used components (L, C) and the application environment.

PARAMETER		I_{short}	I_{short}	UNIT	
		$T_{charge} = 20 \text{ ms}$	$T_{charge} = 25 \text{ ms}$		
I_{prog}	Equivalent for programming activation field strength	$Q_{op} \geq 60$ -40 to 85 °C	0.32	0.23	mA
I_{prog}	Equivalent for programming activation field strength	$Q_{op} \geq 30$ -40 to 85 °C	0.64	0.46	mA

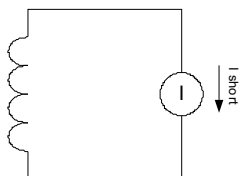

Figure 2. Short Circuit Current

RECOMMENDED EXTERNAL COMPONENTS

ANTENNA

PARAMETER		TEST CONDITIONS	MIN	NOM	MAX	UNIT
LR	Inductance of antenna ($d_{LR} = \pm 2.8\%$)	25°C CR = 470 pF, $\pm 2\% f = 134.2$ kHz	2.586	2.66	2.734	mH
$d_{LR/LRdt}$	Temperature coefficient of LR	-40 to 85°C			250	ppm/K
QLR ⁽¹⁾	Quality factor of LR	25°C* $Q_{op} > 30^{(2)}$ (1)		60		

(1) Q_{op} is Q factor measured when device is assembled on PCB.

(2) Due to tester limitations currently only the value given in brackets can be guaranteed.

RESONANCE CIRCUIT CAPACITOR

PARAMETER		TEST CONDITIONS	MIN	NOM	MAX	UNIT
CR	Resonance capacitor	LR = 2.66 mH $\pm 2.8\%$	460.6	470	479.4	pF
	Dielectric	$d_{LR/LRdt} \leq 250 \text{ ppm}^{(1)}$		NPO		
QCR	Quality factor		2000			
RF	Operating voltage		20	50		Vpp

(1) This type is recommended, if no temperature compensation is required for LR

CHARGE CAPACITOR

PARAMETER		TEST CONDITIONS	MIN	TYP	MAX	UNIT
C _L	Charge capacitor	25°C f _{meas} = 1 kHz	198	220	242	nF
C _{Ldielectric}	Dielectric of C _L			X7R		
V _{CL}	Operating voltage		16			Vdc

OTHER COMPONENTS

PARAMETER		TEST CONDITIONS	MIN	NOM	MAX	UNIT
R _{VCL}	V _{CL} resistor	Depends on application circuit		1		MΩ
R _{load}	V _{BATI} load resistor	Depends on application circuit		100		kΩ
C _{BAT}	Battery capacitor			100		nF
C _{BATI}	BATI capacitor			100		nF

RECOMMENDED TEST INTERFACE PARAMETERS

PARAMETER		MIN	NOM	MAX	UNIT
V _{CL}	Supply voltage for trim/test		5		V
V _{IH}	High level input voltage, TDAT, TCLK & TEN	0.9 × V _{CL}		1.1 × V _{CL}	V
V _{IL}	Low level input voltage, TDAT, TCLK & TEN	0		0.1 × V _{CL}	V
f _{Tclk}	Clock frequency		TCLK 134		kHz
t _r , t _f	Rise and fall time, TDAT, TCLK, TEN		50		ns
t _{TclkL}	Test clock low time		3.7		μs
t _{TclkH}	Test clock high time		3.7		μs
t _{Tres}	Test reset time		14		ms
t _{TRc}	Test reset to clock time		1		μs
t _{Tds}	Test data setup time		1		μs
t _{Tdh}	Test data hold time		1		μs

TMS37157 BLOCK DIAGRAM

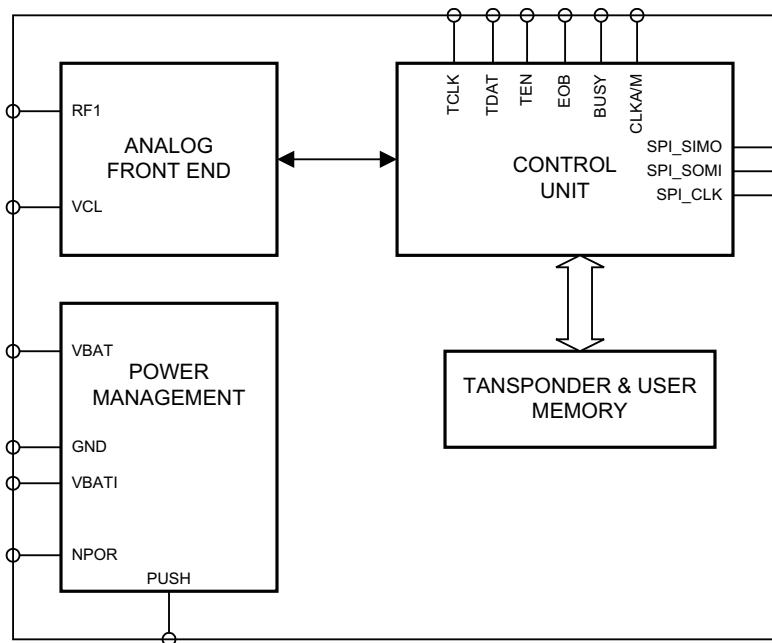

BLOCK DESCRIPTION

Analog Front End

The Analog Front End implements all of the analog functions needed to support the TMS37157 transponder functions. It enables reception and transmission of LF signals when the transponder is active, and rectifies incoming LF energy and stores it in an external charge capacitor, to power the device.

The Analog Front End also contains the capacitor array used to trim the transponder's resonance circuit and a clock regenerator function, which is able to recover the clock from an incoming signal so it can be used by the transponder functions.

Control Unit

DST Transponder

The transponder implemented in the TMS37157 is compatible with Texas Instruments' DST ("Digital Signature Transponder") transponder. In addition the TMS37157 provides additional Memory for customer use.

CRC Calculation

A hardware cyclic redundancy check calculation engine is implemented in the Control Unit to provide error detection.

Memory Access

The Control Unit interfaces to the on-chip EEPROM. During power-up, the Control Unit reads the configuration parameters stored in the EEPROM and initializes the TMS37157 circuitry accordingly, and at various times during device operation it can read EEPROM data and provide it, for example, to a microcontroller.

SPI Interface

The Control Unit provides an SPI interface that allows it to communicate with a microcontroller. Via this interface, for example, the microcontroller is able to access the contents of the TMS37157 EEPROM.

Test Interface

The Control Unit provides a test interface that allows customers to trim the LF antenna's resonance circuit.

Transponder and User Memory

The Transponder Memory comprises a total of 126 bytes, organized in pages. Memory space is apportioned as follows:

- User Data 121 bytes
- Serial Number + Manufacturer Code 4 bytes
- Selective Address 1 byte

	MSB				LSB				
SELECT. ADDRESS	LOCK	e.g PASSWORD							PAGE 1
USER DATA	LOCK	DATA							PAGE 2
UNIQUE IDENTIFICATION	LOCK		SERIAL NUMBER			MANUF. CODE			PAGE 3
USER DATA	LOCK				DATA				PAGE 8
USER DATA	LOCK				DATA				PAGE 9
USER DATA	LOCK				DATA				PAGE 10
USER DATA	LOCK				DATA				PAGE 11
USER DATA	LOCK				DATA				PAGE 12
USER DATA	LOCK				DATA				PAGE 13
USER DATA	LOCK				DATA				PAGE 14
USER DATA	LOCK				DATA				PAGE 15

	1	MSB	8	16	24	32	40	LSB
USER DATA	LOCK			DATA				PAGE 40
USER DATA	LOCK			DATA				PAGE 41
USER DATA	LOCK			DATA				PAGE 42
USER DATA	LOCK			DATA				PAGE 43
USER DATA	LOCK			DATA				PAGE 44
USER DATA	LOCK			DATA				PAGE 45
USER DATA	LOCK			DATA				PAGE 46
USER DATA	LOCK			DATA				PAGE 47
USER DATA	LOCK			DATA				PAGE 48
USER DATA	LOCK			DATA				PAGE 49
USER DATA	LOCK			DATA				PAGE 50
USER DATA	LOCK			DATA				PAGE 51
USER DATA	LOCK			DATA				PAGE 52
USER DATA	LOCK			DATA				PAGE 53
USER DATA	LOCK			DATA				PAGE 54
USER DATA	LOCK			DATA				PAGE 55

Selective Address

Page 1 of the transponder memory contains a Selective Address (password) and lock bit. The Selective Address is used for selective programming, selective locking, selective protecting and selective reading.

The Selective Address may be programmed by the user via the program page 1 command (as long as the Selective Address lock bit is not set). The lock bit can be set by the user via the lock page 1 command. Once set, the lock bit cannot be reset.

To activate the selective addressing feature, the user must write a value other than 0xFF into page 1. If the Selective Address is not 0xFF, it is compared with the Selective Address received from the base station during a command write phase. If the Selective Address is 0xFF (the factory default), no such comparison is performed and selective addressing is disabled.

Whenever pages 1, 2 or 3 are accessed, the Selective Address (from page 1) is returned in the corresponding read phase, together with page 2 and the Manufacturer Code and Serial Number (from page 3). The status of the page 1 lock bit (1=locked) is only returned when page 1 is accessed.

Page 2

Page 2 of the transponder memory contains 8 bits of user data and lock bit.

Page 2 is typically used for numbering keys in an application (e.g. the key number), it can also be used to save the value of the trim capacitor array or for anything else. It may be programmed by the user using the program page 2 command (as long as the lock bit is not set). The lock bit can be set by the user via the lock page 2 command. Once set, the lock bit cannot be reset.

Whenever pages 1, 2 or 3 are accessed, page 2 is returned in the corresponding read phase, together with the Selective Address (from page 1) and the Manufacturer Code and Serial Number (from page 3). The status of the page 2 lock bit (1=locked) is only returned when page 2 is accessed.

Unique Identification

Page 3 of the transponder memory contains an 8-bit Manufacturer Code and a 24-bit Serial Number. The Manufacturer Code and Serial Number are programmed and locked during manufacture and cannot be changed.

The Manufacturer Code is used to distinguish between different devices, the Manufacturer Code of the TMS37157 is 0x0E. The Serial Number is unique for every single TMS37157 device.

Whenever pages 1, 2 or 3 are accessed, the Manufacturer Code and Serial Number (from page 3) are returned in the corresponding read phase, together with the Selective Address (from page 1) and page 2. The status of the page 3 lock bit (1=locked) is only returned when page 3 is accessed.

User Data

The Transponder Memory provides the Pages 2, 8 to 15 and 40 to 55 for data storage. This memory is available to store any data defined by the user or application.

POWER MANAGEMENT

The Power Management block is responsible for the master control of all power supplies plus several additional tasks, such as responding when a push button is pressed, generating reset signals and receiving LF transponder commands.

A block diagram of the power management function is shown in Figure 3. Activation of a push signal is detected by an ultra low-power detection circuit. While waiting for a high signal at PUSH, the only active component in the TMS37157 is a flip-flop, whose output is set when PUSH is set high. When this happens, SW5 is closed and the Control Unit is powered up and initialized. Also VBAT is switched to VBATI to power up a connected microcontroller. The Microcontroller can, after performing its desired actions, send a Power Down Command to the TMS37157, bringing the TMS37157 in the ultra low power mode (the Flip Flip is cleared and VBATI is disconnected waiting for a PUSH High signal to appear).

When the Transponder Interface receives an MSP Access Command the Control Unit is powered up and initialized and sets the VBATI ON signal, which switches on the μ C. The Control Unit waits for μ C to fetch the data, process it and send the processed data back to the Control Unit. The TMS37157 switches VBATI off and waits for the RF to switch. If it detects a loss of the RF it transmits the MSP Access data back. Then the TMS37157 goes into the ultra low power sleep mode again. Throughout the whole MSP Access process the RF of the reader has to stay on, because the TMS37157 Control Unit is powered out of the RF - field.

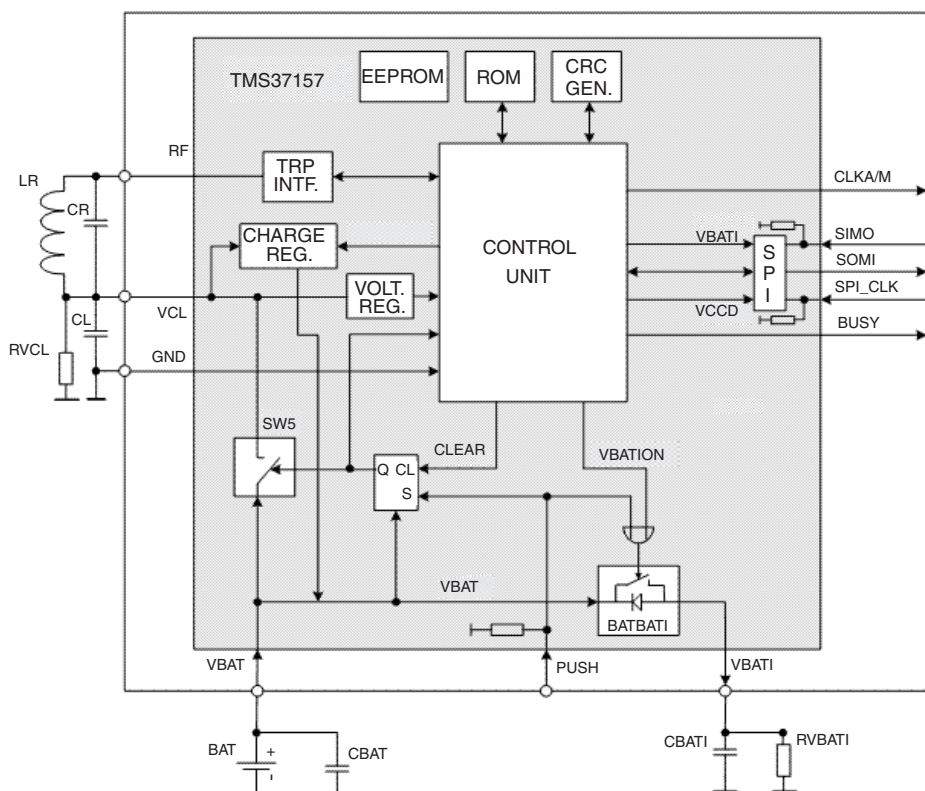

Figure 3. TMS37157 Power Management

ADDRESSING OF THE TRANSPONDER

The addressing mode of the TMS37157 is defined by the content of page 1.

General Addressing Page 1 = 0xFF

Selective Addressing Page 1 <> 0xFF

Standard configuration is General Addressing. Selective Addressing is activated by programming a value other than 0xFF into page 1 of the TMS37157 EEPROM. Selective Addressing affects the Lock Page, Protect Page (not available for Page 1-3) and Program Page commands for page 1 to page 15 and page 40 to page 55. Here the selective address has to be added to the Command. A Read Page of page 1 – 3 always gives back the selective address.

A General Read is still possible on all pages. For page 1 – 3 a selective read be can done.

To switch off Selective Addressing a selective program page 1 Command with User Data 0xFF has to be send to the TMS37157.

USE OF THE LOCK BIT

All pages can be locked by setting the corresponding lock bit. Locked pages can not be reprogrammed anymore. The Lock is irreversible.

USE OF THE PROTECTION BIT

Pages 8-15 and 40-55 can be protected by setting the corresponding Protection Bit. Protected pages can only be reprogrammed via SPI. The TMS37157 will not answer to a program command on a protected page. General and Selective Read commands are still possible on protected pages. The protection is irreversible.

PULSE POSITION MODULATION

With Pulse Position Modulation the information is carried in the period duration of a bit (t_{bitL} , t_{bitH}). A bit consists of a pulse pause (t_{off}) and a pulse activation (t_{onL} , t_{onH}).

The difference of period durations at the reader must be selected in way that in case of a low bit the duration at the transponder location is lower than the High Bit Threshold Detection Time (t_{Hdet}). For a high bit, the bit duration must at the transponder location must be higher that the High Bit Threshold Detection Time (t_{Hdet}).

PPM in Case of General Read

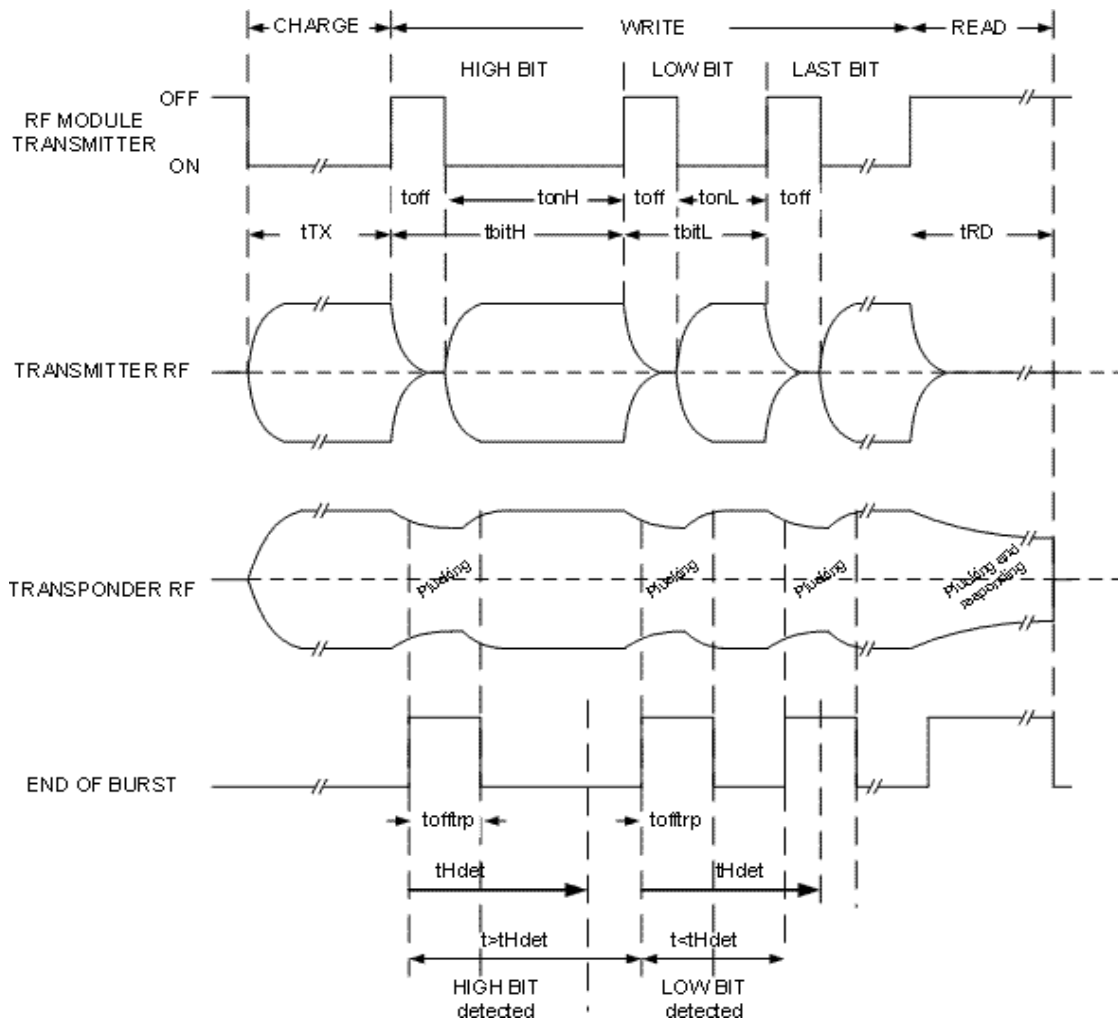

Figure 4. PPM in Case of General Read

If the Pause between two positive transitions of EOB is at least as long as t_{Hdet} the Transponder writes a one. If the Pause is shorter it writes a 0.

PPM in Case of Programming or Locking

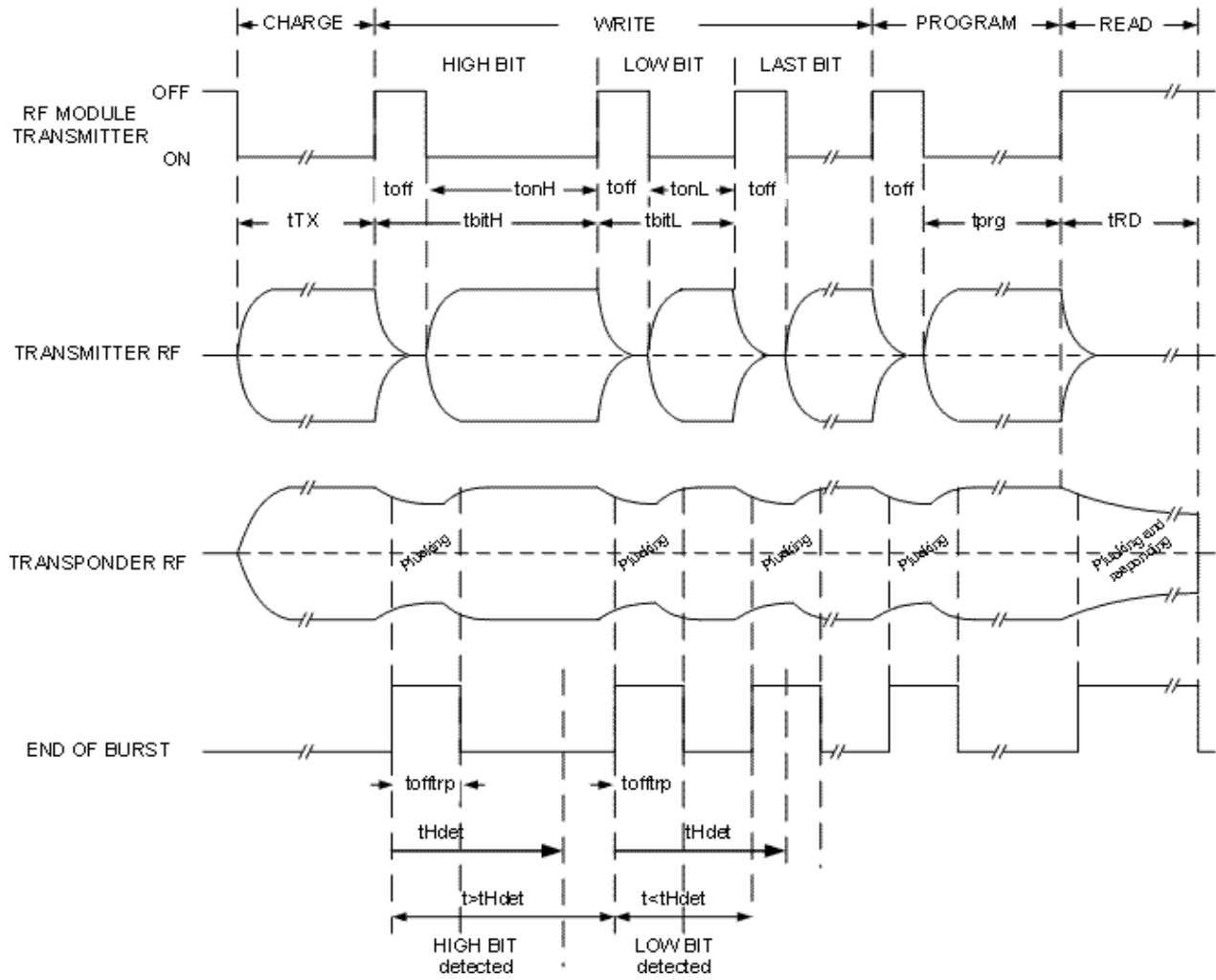

Figure 5. PPM in Case of Programming

For a program, lock or protect command a RF burst from the transmitter is needed after transmitting the program, lock or protect command, the length has to be at least t_{prg} .

TMS37157 COMMANDS

This chapter describes the commands and data that can be transferred to and from the TMS37157 via its contact less LF interface, SPI and Test interfaces.

When communicating with the transponder following naming conventions are used:

- Data Transmission from the base station to the transponder is called “write” and “write data are transferred”.
- Data Transmission from the transponder to the base station is called “read” and “read data re transferred”.

This is applied independently from the command that is executes whether it is a read, write, program or authentication function.

Write Formats

In order to send commands to the TMS37157 LF interface, the user sends a Write Address byte comprising a 2-bit Command field and a 6-bit Page field. The Command field, which is transmitted first, determines the function to be executed and whether command comprises additional data bytes that must also be sent. The Page field specifies the target of the command.

Table 1 shows which additional data bytes must be included with each command type. The elements for each command are sent from left to the right of this table.

Table 1. Data Bytes for different command types

FUNCTION	WRITE ADDRESS		SELECTIVE ADDRESS	WRITE DATA	FRAME BCC
	COMMAND FIELD	PAGE FIELD			
	MSB	LSB			
General read page, battery check	00	X			
Selective read page	11	X	X		X
Program page; MSP access	01	X		X ⁽¹⁾	X
Selective program page	01	X	X	X ⁽¹⁾	X
Lock page	10	X			X
Selective lock page	10	X	X		X
Protect page	11	X			X
Selective protect page	11	X	X		X

(1) Length of Write Data is 5 bytes for a program page command and 6 bytes for an MSP Access command.

The summary for the available write address via the LF interface are shown in Table 2. It shows the valid Command and Page field combinations supported by the TMS37157.

Table 2. Valid Command and Page Field Combinations (Command)

	WRITE ADDRESS		HEX VALUE	
	MSB	LSB		
	P P P P P P	C C		
	PAGE FIELD	COMMAND FIELD		
	MSB	LSB		
Page 1	000001	00	04h	General Read Page 1
	000001	01	05h	Program/Selective Program Page 1
	000001	10	06h	Lock/Selective Lock Page 1
	000001	11	07h	Selective Read Page 1
Page 2	000010	00	08h	General Read Page 2
	000010	01	09h	Program/Selective Program Page 2
	000010	10	0Ah	Lock/Selective Lock Page 2
	000010	11	0Bh	Selective Read Page 2

Table 2. Valid Command and Page Field Combinations (Command) (continued)

WRITE ADDRESS				
Page 3	000011	00	0Ch	General Read Page 3
	000011	01	0Dh	Program/Selective Program Page 3
	000011	10	0Eh	Lock/Selective Lock Page 3
	000011	11	0Fh	Selective Read Page 3
Page 8	001000	00	20h	General Read Page 8
	001000	01	21h	Program/Selective Program Page 8
	001000	10	22h	Lock/Selective Lock Page 8
	001000	11	23h	Set Protection Bit/ Selective Set Protection Bit of Page 8
Page 9	001001	00	24h	General Read Page 9
	001001	01	25h	Program/Selective Program Page 9
	001001	10	26h	Lock/Selective Lock Page 9
	001001	11	27h	Set Protection Bit/ Selective Set Protection Bit of Page 9
Page 10	001010	00	28h	General Read Page 10
	001010	01	29h	Program/Selective Program Page 10
	001010	10	2Ah	Lock/Selective Lock Page 10
	001010	11	2Bh	Set Protection Bit/ Selective Set Protection Bit of Page 10
Page 11	001011	00	2Ch	General Read Page 11
	001011	01	2Dh	Program/Selective Program Page 11
	001011	10	2Eh	Lock/Selective Lock Page 11
	001011	11	2Fh	Set Protection Bit/ Selective Set Protection Bit of Page 11
Page 12	001100	00	30h	General Read Page 12
	001100	01	31h	Program/ Selective Program Page 12
	001100	10	32h	Lock/ Selective Lock Page 12
	001100	11	33h	Set Protection Bit/ Selective Set Protection Bit of Page 12
Page 13	001101	00	34h	General Read Page 13
	001101	01	35h	Program/ Selective Program Page 13
	001101	10	36h	Lock/ Selective Lock Page 13
	001101	11	37h	Set Protection Bit/ Selective Set Protection Bit of Page 13
Page 14	001110	00	28h	General Read Page 14
	001110	01	39h	Program/ Selective Program Page 14
	001110	10	3Ah	Lock/ Selective Lock Page 14
	001110	11	3Bh	Set Protection Bit/ Selective Set Protection Bit of Page 14
Page 15	001111	00	3Ch	General Read Page 15
	001111	01	3Dh	Program/ Selective Page 15
	001111	11	3Eh	Lock/ Selective Lock Page 15
	001111	11	3Fh	Set Protection Bit/ Selective Set Protection Bit of Page 15
Page 19	010011	00	4Ch	Battery Check
Page 26	011010	00	68h	Battery Charge ⁽¹⁾
Page 31	011111	01	7Dh	MSP Access (Program Page 31)
Page 40	101000	00	A0h	General Read Page 40
	101000	01	A1h	Program/ Selective Program Page 40

(1) The TMS37157 will not respond to a Battery Charge Command. The RF has to stay on after transmitting the Write Address. To end the battery charge command any other command can be performed.

Table 2. Valid Command and Page Field Combinations (Command) (continued)

		WRITE ADDRESS			
		101000	10	A2h	Lock/ Selective Lock Page 40
		101000	11	A3h	Set Protection Bit/ Selective Set Protection Bit of Page 44
Page 41		101001	00	A4h	General Read Page 41
		101001	01	A5h	Program/ Selective Program Page 41
		101001	10	A6h	Lock/ Selective Lock Page 41
		101001	11	A7h	Set Protection Bit/ Selective Set Protection Bit of Page 41
Page 42		101010	00	A8h	General Read Page 42
		101010	01	A0h	Program/ Selective Program Page 42
		101010	10	AAh	Lock/ Selective Lock Page 42
		101010	11	ABh	Set Protection Bit/ Selective Set Protection Bit of Page 42
Page 43		101011	00	ACh	General Read Page 43
		101011	01	ADh	Program/ Selective Program Page 43
		101011	10	A Eh	Lock/ Selective Lock Page 43
		101011	11	AFh	Set Protection Bit/ Selective Set Protection Bit of Page 43
Page 44		101100	00	B0h	General Read Page 44
		101100	01	B1h	Program/ Selective Program Page 44
		101100	10	B2h	Lock/ Selective Lock Page 44
		101100	11	B3h	Set Protection Bit/ Selective Set Protection Bit of Page 44
Page 45		101101	00	B4h	General Read Page 45
		101101	01	B5h	Program/ Selective Program Page 45
		101101	10	B6h	Lock/ Selective Lock Page 45
		101101	11	B7h	Set Protection Bit/ Selective Set Protection Bit of Page 45
Page 46		101110	00	B8h	General Read Page 46
		101110	01	B9h	Program/ Selective Program Page 46
		101110	10	BAh	Lock/ Selective Lock Page 46
		101110	11	BBh	Set Protection Bit/ Selective Set Protection Bit of Page 46
Page 47		101111	00	BCh	General Read Page 47
		101111	01	BDh	Program/ Selective Program Page 47
		101111	10	BEh	Lock/ Selective Lock Page 47
		101111	11	BFh	Set Protection Bit/ Selective Set Protection Bit of Page 47
Page 48		110000	00	C0h	General Read Page 48
		110000	01	C1h	Program/ Selective Program Page 48
		110000	10	C2h	Lock/ Selective Lock Page 48
		110000	11	C3h	Set Protection Bit/ Selective Set Protection Bit of Page 48
Page 49		110001	00	C4h	General Read Page 49
		110001	01	C5h	Program/ Selective Program Page 49
		110001	10	C6h	Lock/ Selective Lock Page 49
		110001	11	C7h	Set Protection Bit/ Selective Set Protection Bit of Page 49
Page 50		110010	00	C8h	General Read Page 50
		110010	01	C9h	Program/ Selective Program Page 50
		110010	10	CAh	Lock/ Selective Lock Page 50
		110010	11	CBh	Set Protection Bit/ Selective Set Protection Bit of Page 50
Page 51		110011	00	CCh	General Read Page 51

Table 2. Valid Command and Page Field Combinations (Command) (continued)

WRITE ADDRESS				
	110011	01	CDh	Program/ Selective Program Page 51
	110011	10	CEh	Lock/ Selective Lock Page 51
	110011	11	CFh	Set Protection Bit/ Selective Set Protection Bit of Page 51
Page 52	110100	00	D0h	General Read Page 52
	110100	01	D1h	Program/ Selective Program Page 52
	110100	10	D2h	Lock/ Selective Lock Page 52
	110100	11	D3h	Set Protection Bit/ Selective Set Protection Bit of Page 52
Page 53	110101	00	D4h	General Read Page 53
	110101	01	D5h	Program/ Selective Program Page 53
	110101	10	D6h	Lock/ Selective Lock Page 53
	110101	11	D7h	Set Protection Bit/ Selective Set Protection Bit of Page 53
Page 54	110110	00	D8h	Lock/ Selective Lock Page 54
	110110	01	D9h	Program/Selective Page 54
	110110	10	DAh	Lock/Selective Lock Page 54
	110110	11	DBh	Set Protection Bit/ Selective Set Protection Bit of Page 54
Page 55	110111	00	DCh	General Read Page 55
	110111	01	DDh	Program/Selective Page 55
	110111	10	DEh	Lock/Selective Lock Page 55
	110111	11	DFh	Set Protection Bit/ Selective Set Protection Bit of Page 55

Read Formats

The Read phase starts with each deactivation of the transmitter, which is detected by the transponder, because the transponder resonance circuit RF amplitude drops. The transponder starts with transmission of 16 Pre-bits. During this phase the resonance circuit resonates with the low bit transmit frequency (f_L). During transmission of the read data or response, the resonance circuit frequency is shifted between the low bit transmit frequency (f_L) and the high bit transmit frequency (f_H).

The typical data low bit frequency is 134.7 kHz; the typical data high bit frequency is 123.7 kHz. The low and high bits have different durations, because each bit takes 16 RF cycles to transmit.

Figure 6 shows the FM principle used. Regardless of the number of low and high bits, the transponder response duration is always less than 15 ms.

Data encoding is done in NRZ mode (Non Return to Zero). The clock is derived from the RF carrier by a divide-by-16 function.

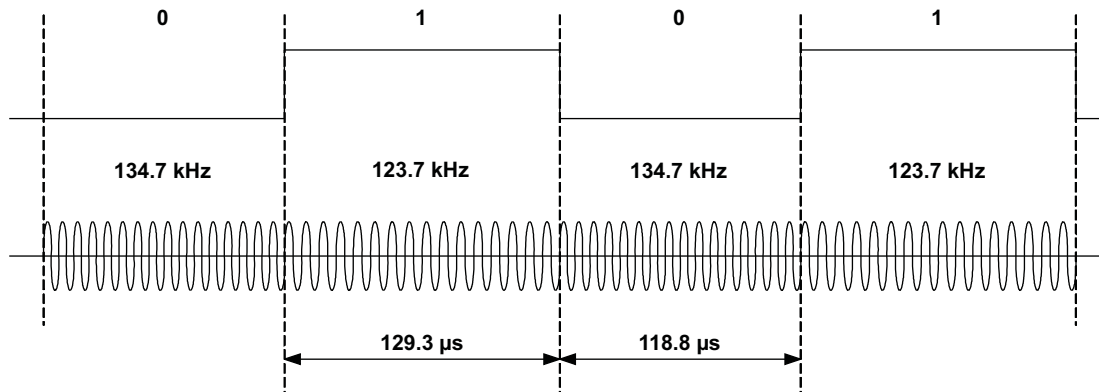

Figure 6. FM Principle Used in Read Function of Transponders

After a charge phase only, having no write phase, the transponder discharges its capacitor at the end of the pre-bit phase, which results in no response. If a valid function was detected during the write phase, the complete read data format is transmitted. The content of the read data format depends on the previously executed function.

When the last bit has been sent, the capacitor is discharged. During discharge no charge-up is possible.

A sufficiently long read time (t_{RD}) must be provided to ensure that the complete read data format can be received.

During the response (read) phase, the transponder transmits 96 bits of data, formatted as described below. The content of the response depends on which page was addressed.

All read data starts with a 16-bit preamble followed by an 8-bit start byte (7Eh), and ends with the 8-bit Read Address and 16-bit Read Frame BCC. All parts of the read data are transmitted LSB first.

The Read Address byte comprises a 2-bit Status field, which is transmitted first and contains status information, and a 6-bit Page field, which contains page and additional status information. The contents of the Status field depend on which page is being addressed.

Table 3. Overview of Read Data Format Content

Page	READ DATA FORMAT BYTE					
	4	5	6	7	8	9
1	Sel. Address	Page 2	Man. Code	Serial No.	Serial No.	Serial No.
2	Sel. Address	Page 2	Man. Code	Serial No.	Serial No.	Serial No.
3	Sel. Address	Page 2	Man. Code	Serial No.	Serial No.	Serial No.
8	Page 2	Page 8	Page 8	Page 8	Page 8	Page 8
9	Page 2	Page 9	Page 9	Page 9	Page 9	Page 9
10	Page 2	Page 10	Page 10	Page 10	Page 10	Page 10
11	Page 2	Page 11	Page 11	Page 11	Page 11	Page 11
12	Page 2	Page 12	Page 12	Page 12	Page 12	Page 12
13	Page 2	Page 13	Page 13	Page 13	Page 13	Page 13
14	Page 2	Page 14	Page 14	Page 14	Page 14	Page 14
15	Page 2	Page 15	Page 14	Page 14	Page 14	Page 14
19	Battery level	'00000000'	'00000000'	'00000000'	'00000000'	'00000000'
31	MSP Data	MSP Data	MSP Data	MSP Data	MSP Data	MSP Data
40	Page 2	Page 40	Page 40	Page 40	Page 40	Page 40
41	Page 2	Page 41	Page 41	Page 41	Page 41	Page 41
42	Page 2	Page 42	Page 42	Page 42	Page 42	Page 42
43	Page 2	Page 43	Page 43	Page 43	Page 43	Page 43
44	Page 2	Page 44	Page 44	Page 44	Page 44	Page 44
45	Page 2	Page 45	Page 45	Page 45	Page 45	Page 45
46	Page 2	Page 46	Page 46	Page 46	Page 46	Page 46
47	Page 2	Page 47	Page 47	Page 47	Page 47	Page 47
48	Page 2	Page 48	Page 48	Page 48	Page 48	Page 48
49	Page 2	Page 49	Page 49	Page 49	Page 49	Page 49
50	Page 2	Page 50	Page 50	Page 50	Page 50	Page 50
51	Page 2	Page 51	Page 51	Page 51	Page 51	Page 51
52	Page 2	Page 52	Page 52	Page 52	Page 52	Page 52
53	Page 2	Page 53	Page 53	Page 53	Page 53	Page 53
54	Page 2	Page 54	Page 54	Page 54	Page 54	Page 54
55	Page 2	Page 55	Page 55	Page 55	Page 55	Page 55

Table 4 to Table 5 show the valid Status and Page field combinations supported by the TMS37157.

Table 4. Valid Responses, If Page 1 to 3 is Addressed

READER			TRANSPONDER		
Write Function	Write Address		Read Address		Valid Responses
General Read Page 1 to 3	000001	00	000001	00	Read unlocked Page 1...3
 000011		000011	10	Read locked Page 1...3
Selective Read Page 1 to 3	000001	11	000001	00	Read unlocked Page 1...3
 000011		000011	10	Read locked Page 1...3
Program/Selective Program Page 1 to 3	000001	01	000001	01	Programming done on Page 1...3
		000011	10	Read locked Page 1...3 programming not executed
	000011		000011	00	Read unlocked Page 1...3, programming not executed (field strength too low)
		000000	01	Programming Page 1...3 done, but possibly not reliable
Lock / Selective Lock Page 1 to 3	000001	10	000001	10	Read locked Page 1...3
		000011	00	Read unlocked Page 1...3, locking not execute (field strength too low)
	000011		000000	00	Read unlocked Page 1...3, locking not correctly executed
		000000	10	Read locked Page 1...3, but locking possibly not reliable

Table 5. Valid Responses, if Page 8 to 15 is Addressed

READER			TRANSPONDER		
Write Function	Write Address		Read Address		Possible Responses
General Read Page 8...15	001000	00	001000	00	Read unlocked Page 8...15
 001111		001111	10	Read locked Page 8...15
Program/ Sel. Program Page 8...15	001000	01	001000	01	Page 8...15 is locked, programming not executed
		001111	10	Page 40...55 is locked, programming not executed
	001111		001111	00	Page 8...15 is unlocked, programming not executed (field strength too low)
		0000000	01	Programming Page 8...15 done, but possibly not reliable
Lock/ Selective Lock Page 8...15	001000	10	001000	10	Read locked Page 8...15
		001111	00	Read unlocked Page 8...15, locking not executed (field strength too low)
	001111		0000000	00	Read unlocked Page 8...15, locking not correctly executed
		0000000	10	Read locked Page 8...15, but locking possibly not reliable
Set/ Selective Set Protection Bit Page 8...15	001000	11	001000	00	Read unlocked Page 8...15, Protection bit was not set (field strength too low)
		001111	10	Read locked Page 8...15, Protection bit was not set (field strength too low)
	001111		001111	11	Protection Bit of Page 8...15 was set
		0000000	11	Setting of Protection bit was executed, but possibly not reliable

Table 6. Valid Responses, If Battery Check (Page 19) is Addressed

READER			TRANSPONDER		
Write Function	Write Address		Read Address		Valid Responses
Read Page 19 (Battery Check)	010011	00	010011	00	Read unlocked Page 19

Table 7. Valid Responses if MSP Access (Page 31) is Addressed

READER			TRANSPONDER		
Write Function	Write Address		Read Address		Possible Responses
Program Page 31 (MSP Access)	011111	01	011111	01	MSP Access execution O.K.
				00	SPI Programming failed
			000000	00	MSP Access execution failed
				01	MSP Access execution failed

Table 8. Valid Responses, if Page 40 to 55 is Addressed

READER			TRANSPONDER		
Write Function	Write Address		Read Address		Possible Responses
General Read Page 40...55	101000	00	101000	00	Read / unlocked Page 40...55
 110110		110110	10	Read / locked Page 40...55
Program/ Sel. Program Page 40...55	101000	01	101000	01	Programming done on Page 40...55
		110110	10	Page 40...55 is locked, programming not executed
	110110		00	Page 40...55 is unlocked, programming not executed (field strength too low)	
			0	01	Programming Page 40...55 done, but possibly not reliable
Lock/ Selective Lock Page 40...55	101000	10	101000	10	Read locked Page 40...55
		110110	00	Read unlocked Page 40...55, locking not executed (field strength too low)
	110110		000000	00	Read unlocked Page 40...55, locking not correctly executed
				10	Read locked Page 40...55, but locking possibly not reliable
Set/ Selective Set Protection Bit Page 40...55	101000	11	101000	00	Read unlocked Page 40...55, Protection bit was not set (field strength too low)
		110110	10	Read locked Page 40...55, Protection bit was not set (field strength too low)
	110110			11	Protection Bit of Page 40...55 was set
			000000	11	Setting of Protection bit was executed, but possibly not reliable

LF TELEGRAMS – MEMORY ACCESS

Following sections show the structure of the Write - and Read Formats for the Memory Access through the Low Frequency Interface.

Write to Transponder

Read Commands

The write format of the General Read command is shown in [Figure 7](#).

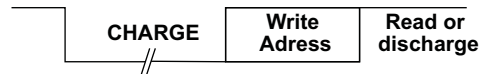

Figure 7. General Read/Get Status Command

The write format of the Selective Read command is shown in [Figure 8](#).

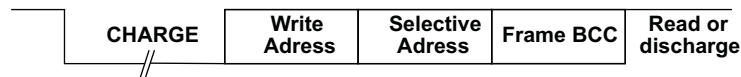

Figure 8. Selective Read

Program Commands

The write format of the general program command is shown in [Figure 9](#).

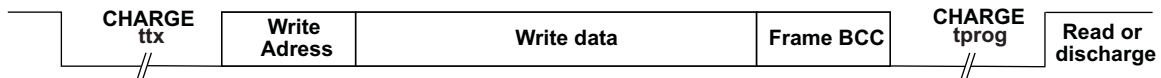

Figure 9. General Program Command

The write format of the selective program command is shown in [Figure 10](#).

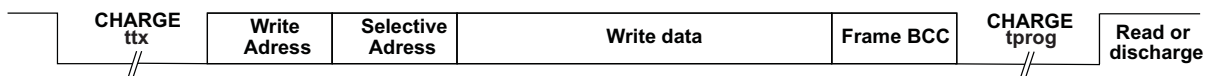

Figure 10. Selective Program Command

Lock and Protect Commands

The write format of the Lock/Protect command is shown in [Figure 11](#).

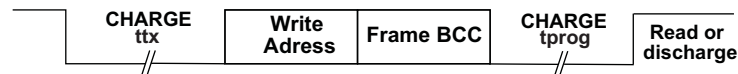

Figure 11. General Lock/Protect

The write format of the Selective Lock/Protect command is shown in [Figure 12](#).



Figure 12. Selective Lock/Protect

Lock and Protect commands share the same write format.

Read From Transponder (Response)

The write format of the General Read command is shown in [Figure 7](#).

Transponder Response Format of the General Read command is shown in [Figure 13](#) and [Figure 14](#). The Response Format is the same for Read, Program and Lock Commands.

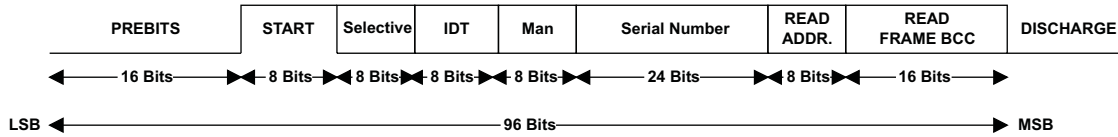

Figure 13. Read Data Format of Page 1, 2, 3

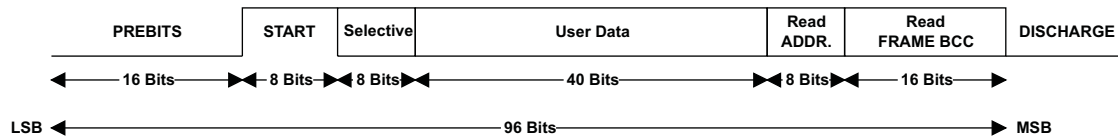

Figure 14. Read Data Format of Page 8–15 and Page 40 to 55

LF TELEGRAMS – SPECIAL FUNCTION

MSP Access

The MSP Access command allows transfer of LF data to and from the MSP 430 microcontroller via the TMS37157 Analog Front End. The microcontroller handles data transfers using the following SPI commands:

- MSP Read Data From PCU (Data In)
- MSP Write Data To PCU (Data Out)

Write Data Format

The write format of the MSP Access command is shown in [Figure 15](#).

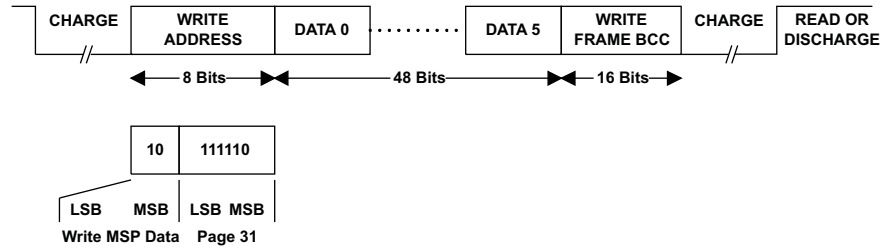
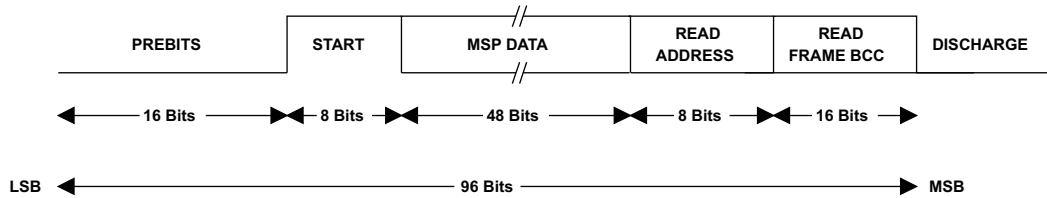

Figure 15. LF Write Format – MSP Access Command

Read Data Format

The read format of the MSP Access command is shown in .

LF Read Format – MSP Access Command



Flow of MSP Access Data Handling

The following sequence is needed to implement an MSP Access command:

- The TMS37157 detects that an MSP Access command has been received and wakes the Microcontroller (e.g. MSP430).
- The Microcontroller reads the status using the SPI command *Get Status*.
- The MSP access request is detected and the data are requested by the Microcontroller. Data bytes are transferred to the Microcontroller using the SPI command *MSP Read Data from PCU*.
- The data bytes are processed and actions executed, as necessary.
- If necessary, the Microcontroller sends response data bytes back to the TMS37157, using the SPI command *MSP Write Data to PCU*.
- After the TMS37157 has detected removal of LF power, the response data bytes are sent back to the base station.

NOTE

The LF field must be present throughout the above sequence (except the last step), otherwise a malfunction of the TMS37157 may occur.

Battery Check

When a Battery Check command has been received, the Control Unit compares the battery voltage with two pre-defined thresholds and responds with the result of the comparison.

Write Data Format

The write format of the Battery Check command is shown in Figure 16.

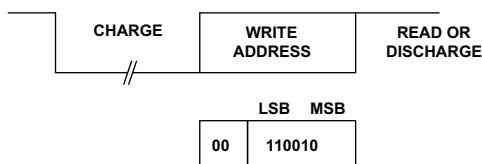

Page 19

Figure 16. LF Write Format – Battery Check Command

Read Data Format

The read format of the Battery Check command is shown in Figure 17.

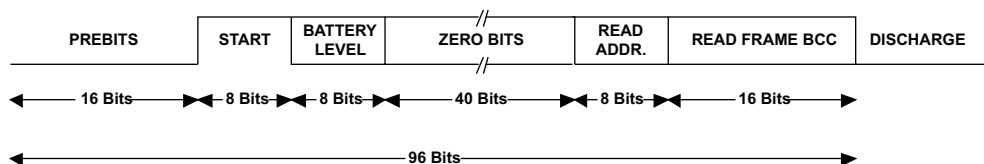

Figure 17. LF Read Format – Battery Check Command

Whenever the TMS37157 receives a Battery Check command, it compares the battery voltage with two pre-defined thresholds – 2.1 V and 2.9 V - and responds with the result of the comparison in accordance with Figure 18.

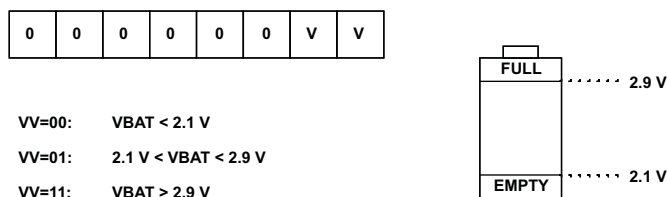

Figure 18. Battery Voltage Comparison

Battery Charge

When a Battery Charge Command has been received the TMS37157 applies a voltage of about 3.4 V to VBAT. The charge current depends mainly on the antenna of the LC Tank Circuit and the Field Strength of the Base Station. The TMS37157 does not answer to a Battery Charge Command. The LF Field has to remain on after transmitting the telegram. The telegram format corresponds to a Read Page 26 Command.

The charging of the battery can be ended by any other command.

Write Data Format

The write data format of the Battery Charge Command is shown in [Figure 19](#).

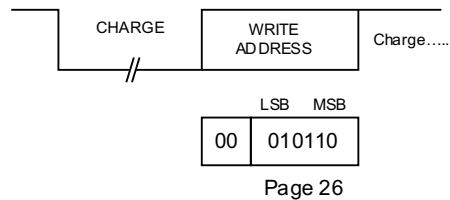

Figure 19. Battery Charge Write Command

SPI COMMANDS

The serial interface for communication between a Microcontroller and the TMS37157 is a synchronous SPI interface which uses clock and data lines to transfer data in bytes. The Microcontroller can use its on-chip hardware USART to implement this interface protocol, which allows efficient Microcontroller operation and simplifies software development. The USART should be used in synchronous SPI (Serial Peripheral Interface) mode, with the Microcontroller designated as the master for all bi-directional communications.

The TMS37157 uses a 3 wire SPI Communication Interface (SIMO, SOMI, CLK). No Enable is necessary. For Synchronization the BUSY Output of the TMS37157 can be used.

SPI Communication Structure

SPI communications can only be initiated by the Microcontroller if the TMS37157 is ready to receive. This is indicated by a low level on the BUSY line – when the first byte is received via the SIMO line, BUSY goes high. A short BUSY low pulse confirms that a byte has been correctly received. After this low pulse, the next byte of the protocol can be sent. If the SPI command requires it, the TMS37157 will then send byte-wise response data via the SOMI line. Each byte sent by the TMS37157 will be confirmed by a short BUSY low pulse. After successful communication, the BUSY line will go from high to low after the last transferred byte and remain low (see [Figure 20](#)).

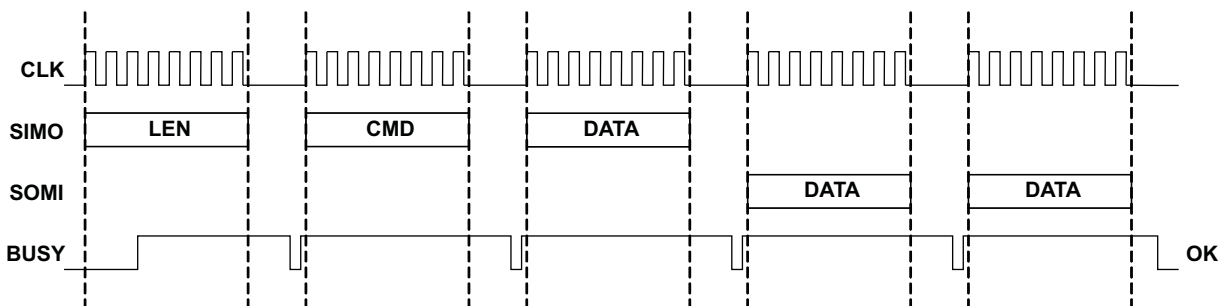

Figure 20. SPI Communication

The initial rising of the busy line happens latest after the 3rd rising edge of the SPI Clock. This indicates that the Front End starts to process the incoming data. It remains high until the Front End is ready with processing of the 8-bit data. After this a low busy pulse (min 30 μ s, typ. 50 μ s, max. 70 μ s) indicates to the Microcontroller that the next data can be sent.

The time the busy line stays high varies depending on the operations the Front End has to perform. The maximum duration is 30ms after all bytes on the SIMO are received. Sending out data on SOMI line depends mainly on the speed of the SPI-Clock. The next SPI Data must be sent within $t_{Busyhigh}=10$ ms. If the next data is not applied within $t_{Busyhigh}$ the SPI command is interrupted.

If an error occurs during SPI communication, the BUSY line remains at the level it was when the error occurred. The following three types of error are possible:

- Error 1: The TMS37157 stops communication via its SPI interface and indicates this by taking BUSY low. The microcontroller has not finished, but BUSY remains low.
- Error 2: The TMS37157 is ready to continue communication via its SPI interface and indicates this by taking BUSY high. The microcontroller has finished, however, and expects BUSY to remain low. After max. 50ms = tBusyhigh an internal watchdog shuts down the whole TMS37157 IC.
- Error 3: If the TMS37157 receives an invalid command it performs a power down command. This command results in a shut down of the whole TMS37157 IC.

SPI Protocol Structure

The first 8 bits sent by the microcontroller contain telegram length information (LEN), which defines the number of following bytes to be transferred via the SIMO line. It is the number of bytes excluding the LEN-byte.

The second 8 bits sent by the microcontroller contain the Command byte (CMD). The first (most significant) two bits of the Command byte determine which of the four different types the command is, and the six least significant bits contain various flags associated with the command (see [Figure 21](#)).

Three types of command are available:

- Transponder Access Command (TAC)
- Enhanced Command (EC)
- Reserved Command (RC) – for future use.

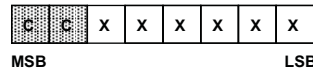

- CC=00: Transponder Access Command (TAC)
- CC=01: n.a.
- CC=10: Enhanced Commands (EC)
- CC=11: Reserved Commands (RC)
- X: Don't care

Figure 21. SPI Command Byte Overview

NOTE

All SPI bits that are either not used or are marked with an "X" are reserved for future use and must be "0".

Transponder Access Commands

The microcontroller can access the contents of the Transponder Memory by sending the TMS37157 a Transponder Access Command via the SIMO line.

The two most significant bits of the Command byte determine the Transponder Access Command and the six least significant bits are don't care. If the contents of the Command byte are invalid for the device configuration, an error condition will be indicated via the BUSY line.

This command is followed by the same Write Address used in LF data transmissions and, if necessary, is followed by further data bytes (e.g. Selective Address, Data). The TMS37157 responds by transferring the relevant transponder data to the microcontroller via the SOMI line (see [Figure 20](#).)

In all cases, responses to Transponder Access Commands are sent without the 16-bit preamble, start byte and BCC that are normally used in LF data transmissions.

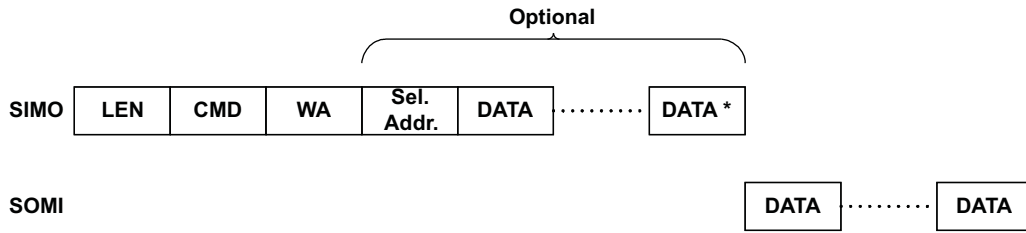

Figure 22. TAC Protocol Overview

NOTE

The format of Transponder Access Commands format is identical to the format used for the LF communication. The optional data has to be added as it is described in the LF section.

In the following figure some examples protocols are shown.

The protocol of the General Read of Page 1 is shown in [Figure 23](#).

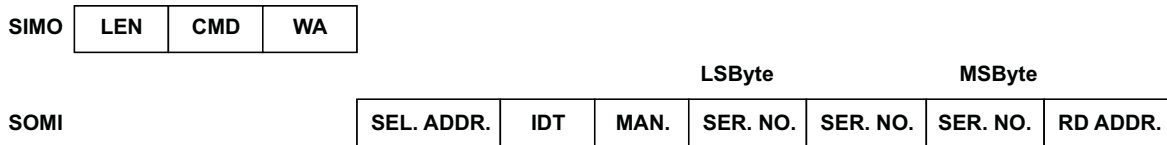

Figure 23. TAC Format – General Read Page 1

Table 9. Example:

Length:	0x02	Two bytes to follow.	
Command:	0x00	= 00 000000 (binary)	
		00 000000	= Transponder Access Command (TAC) = don't care
Write Address:	0x04	= 000001 00 (binary)	
		000001 00	= Page 1 = General Read
Sel. Address:	0x00	Selective address is 0x00	

The 7 byte response depends on the Transponder Memory content.

SIMO = 0x02 0x00 0x04

SOMI = Sel.Ad. IDT Man. Ser.# Ser.# Ser.# Rd.Ad.

The protocol of the Selective Read of Page 1 is shown in [Figure 24](#).

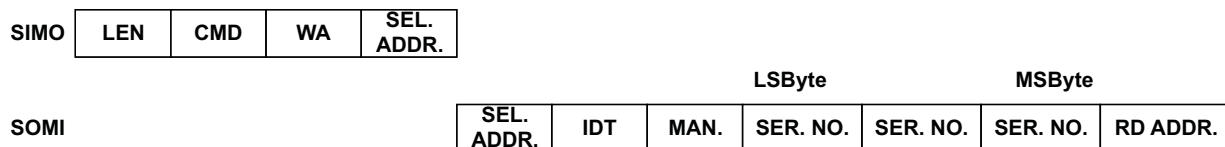

Figure 24. TAC Format – Selective Read Page 1

Example:

The 7 byte response depends on the Transponder Memory content.

Table 10. Example:

Length:	0x03	Three bytes to follow.	
Command:	0x00	= 00 000000 (binary)	
		00 000000	= Transponder Access Command (TAC) = don't care
Write Address:	0x07	= 000001 11 (binary)	
		000001 11	= Page 1 = Selective Read
Sel. Address:	0x03	Selective address is 0x03	

SIMO = 0x03 0x00 0x07 0x03

SOMI = Sel.Ad. IDT Man. Ser.# Ser.# Ser.# Rd.Ad.

The protocol for the read of Page 19 (Battery Check) is shown in [Figure 25](#).

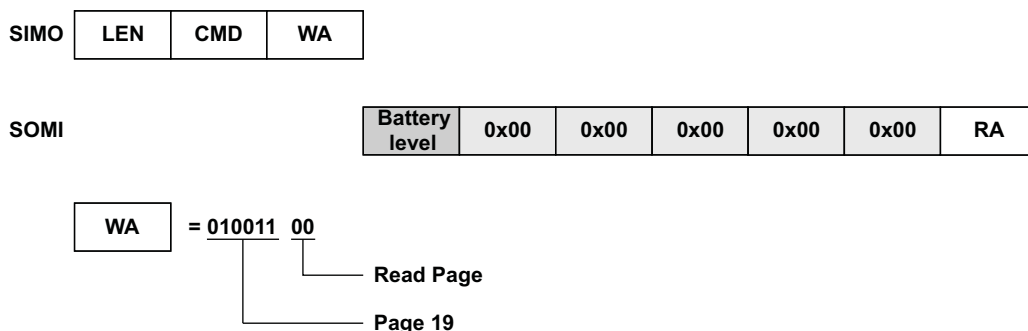

Figure 25. TAC Format – Read Page 19 Battery Check

SIMO = 0x02 0x00 0x4C

Enhanced Commands

The microcontroller can access the contents of the Transponder Memory by sending the TMS37157 a Transponder Access Command via the SIMO line.

The two most significant bits of the Command byte determine the Enhanced Commands, Bit 6 to Bit 3 determine which Enhanced Command should be performed. The two least significant bits determine certain functions connected to the command. If the contents of the command byte are invalid for the device configuration, an error condition will be indicated via the BUSY line.

The TMS37157 supports a number of Enhanced Commands (EC) which are used to transfer commands and data between the microcontroller and the TMS37157 (e.g. to perform a CRC calculation or trim the antenna).

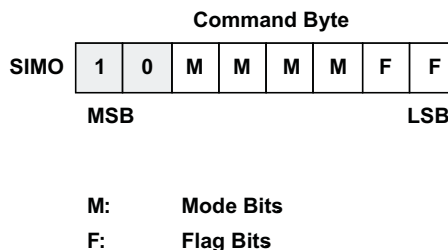

Figure 26. EC Command Byte Contents

The list contained in [Table 11](#) shows the various Enhanced Commands supported by the TMS37157.

Table 11. Supported EC Commands

MMMM = 0	= '0000':	CRC Calculation Command
MMMM = 1	= '0001':	Reserved For Future Use
MMMM = 2	= '0010':	Antenna Trimming with Programming Command
MMMM = 3	= '0011':	Reserved For Future Use
MMMM = 4	= '0100':	Reserved For Future Use
MMMM = 5	= '0101':	Oscillator ON Command
MMMM = 6	= '0110':	Reserved For Future Use
MMMM = 7	= '0111':	CLKA ON command
MMMM = 8	= '1000':	Reserved For Future Use
MMMM = 9	= '1001':	Reserved For Future Use
MMMM = 10	= '1010':	Antenna trimming without Program. Command
MMMM = 11	= '1011':	Reserved for Future Use
MMMM = 12	= '1100':	MSP Read/Write Data from/to Control Unit
MMMM = 13	= '1101':	MSP Read Control Unit Status
MMMM = 14	= '1110':	Power Down Command
MMMM = 15	= '1111':	Reserved For Future Use

CRC CALCULATION COMMAND

The CRC Calculation command allows the microcontroller to use the transponder in the TMS37157 to perform a CRC16 calculation (instead of having to implement it in software). The contents of the command byte and two sample protocols are shown in [Figure 27](#) to [Figure 29](#).

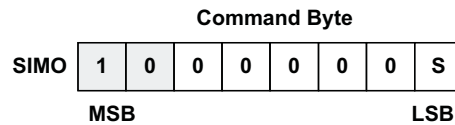

S=0: Start Value is 3791
 S=1: Send Start Value

Figure 27. EC CRC Calculation Command Byte

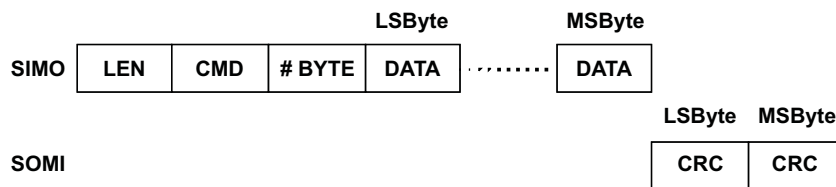

Figure 28. EC Format – CRC Calculation With Start Value "3791"

NOTE

The second byte of the CRC Calculation command (# of Bytes) refers only to data bytes and does not include the start bytes.

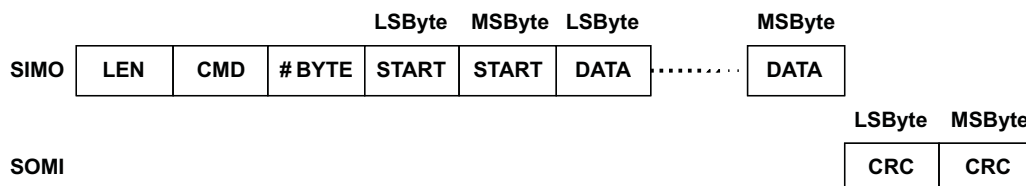

Figure 29. EC Format – CRC Calculation Command Including Start Value

ANTENNA TRIMMING WITHOUT PROGRAMMING COMMAND

The Antenna Trimming without Programming command enables faster trimming than the Antenna Trimming with Programming command. Using this command the trimming capacitors are controlled, but the trim configuration is not stored in the configuration EEPROM. The contents of the command byte and a sample protocol are shown below.

NOTE

In order to use the Antenna Trimming Without Programming function, the trimming capacitors must first be programmed to the OFF state using the Antenna Trimming With Programming command.

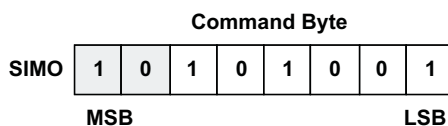

Figure 30. EC Format – Antenna Trimming Without Programming Command Byte

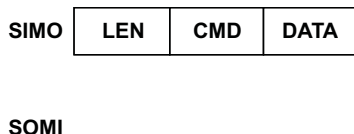

Figure 31. EC Format – Antenna Trimming Without Programming Command Protocol

ANTENNA TRIMMING WITH PROGRAMMING

The Antenna Trimming with Programming command can be used to switch in or out each of the on-chip trimming capacitors. The command programs the trim settings and saves them in a non-volatile EEPROM. The contents of the command byte and a sample protocol are shown below.

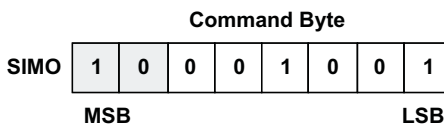

Figure 32. EC Format – Antenna Trimming With Programming Command Byte

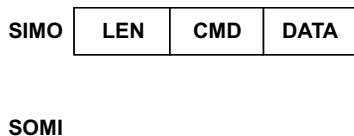

Figure 33. EC Format – Antenna Trimming Command Protocol

OSCILLATOR ON COMMAND

The Oscillator command can be used to enable the TMS37157 LC tank (connected to RF1). The output of this oscillator is presented at the TMS37157 CLKA pin and can be used as a time reference by the microcontroller or for measurements for antenna trimming. The contents of the command byte and a sample protocol are shown in [Figure 34](#) and [Figure 35](#).

NOTE

Once the oscillator has been enabled using the Oscillator On command, its output must be switched to the CLKA pin using the CLKA On command.

This function needs a minimum battery voltage of 2.3V .

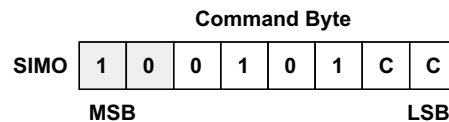

CC=00: Oscillator Off
 CC=01: Oscillator On (134 kHz)
 CC=10: Oscillator/4 On (134/4 kHz)

Figure 34. EC Format – Oscillator Command Byte



SOMI

Figure 35. EC Format – Oscillator Command Protocol

CLKA ON COMMAND

The CLKA command can be used to switch oscillator output to the CLKA pin. This is necessary if during production no trimming is performed and the microcontroller has to trim the LC circuit of the TMS37157. It is recommended to connect CLKA to a Timer clock input of a microcontroller. For a precise time base a crystal or a resonator is needed at the microcontroller.

If CLKA is not needed after trimming, it can be switched off to avoid the noise influences of the CLKA signal line. The contents of the command byte and a sample protocol are shown in [Figure 36](#) and [Figure 37](#).

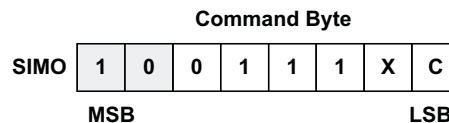

C=0: CLKA Off
 C=1: CLKA On

Figure 36. EC Format – CLKA Command Byte



SOMI

Figure 37. EC Format – CLKA Command Protocol

MSP READ DATA FROM CU (DATA IN)

If the TMS37157 receives a MSP Access Command it signals it by a high Pulse at busy and by setting VBATI. The busy signal could be used as interrupt to wake a microcontroller from Low Power Mode.

The MSP Read Data from CU command can be used to transfer the decoded LF data from the Control Unit in the TMS37157 to the microcontroller. This command returns always 6 bytes to the MSP430. The contents of the command byte and a sample protocol are shown in Figure 38 and Figure 39.



Figure 38. EC Format – MSP Read Data From CU Command Byte



Figure 39. EC Format – MSP Read Data From CU Command Protocol

MSP WRITE DATA TO CU (DATA OUT)

The MSP Write Data to CU command enables the microcontroller to transfer data to the Control Unit in the TMS37157 for LF transmission. The contents of the command byte and a sample protocol are shown in Figure 40 to Figure 41.



Figure 40. EC Format – MSP Write Data to CU Command Byte

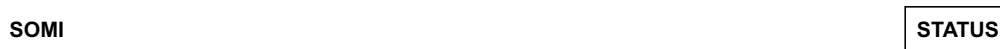

Figure 41. EC Format – MSP Write Data to CU Command Protocol

NOTE

To complete the Data out command the RF Field must be present at least for 500µs after the last SPICLK.

MSP READ CU STATUS (INFO)

The Info command enables the microcontroller to check the Control Unit in the TMS37157 to see if any commands/data are waiting to be processed.

The contents of the command byte and a sample protocol are shown in [Figure 42](#) to [Figure 43](#). The contents of the mask field can be ignored.

[Figure 44](#) shows the contents of the status byte sent as a response.

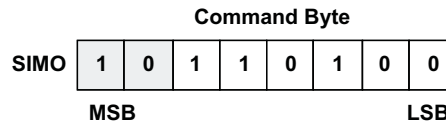

Figure 42. EC Format – MSP Read Status From CU Command Byte

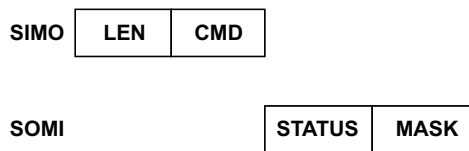
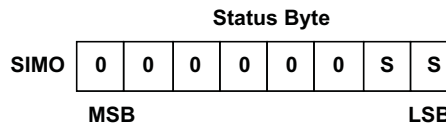

Figure 43. EC Format – MSP Read Status From CU Protocol



SS=01: Push

SS=10: MSP Access

Figure 44. EC Format – MSP Read Status From CU Status Byte

POWER DOWN

The Power Down command enables the microcontroller to shut down the TMS37157 after all operations have been completed. After detecting this command, the Control Unit in the TMS37157 opens SW2 and SW5 and clears the push button detection flip-flop. All TMS37157 functions except push button detection are not powered and the TMS73157 enters a standby condition. The contents of the command byte and a sample protocol are shown in [Figure 45](#) and [Figure 46](#).

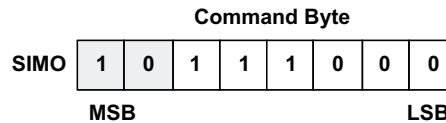

Figure 45. EC Format – Power Down Command Byte



SOMI

Figure 46. EC Format – Power Down Protocol

TEST COMMANDS

The Test Interface is needed to tune the resonance frequency to 134.2kHz during production e.g. at the end of line test.

It comprises two input pins (TEN and TCLK) and one bi-directional pin (TDAT). The CLK signal is used to strobe data into and out of the TMS37157, as shown in the typical timing diagram in [Figure 47](#). Communication via the Test Interface is activated when a valid voltage is applied to VCL and TCLK and TEN are taken high. After waiting a suitable time (the Probe Test Reset period) TCLK can be taken low and the Write Phase started (TEN having already been taken low). Probe Test Write Data is read into the TMS37157 on each rising edge of TCLK. Taking TEN high starts the Read Phase, during which the TMS37157 places new data on the TDAT line on every rising edge of TCLK (data valid on the falling edge of TCLK).

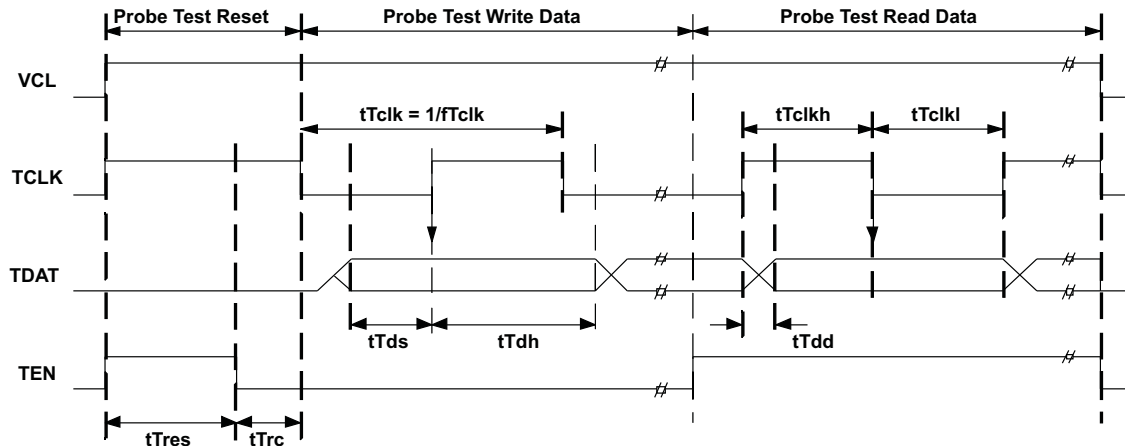

Figure 47. Test Interface Timing

Resonance Frequency Measurement

The first step in the antenna trimming process is to measure the resonance frequency of the antenna circuit. For optimum energy transfer, trimming should be performed with VCL=4V, which is high enough to ensure an LF response, but below the limitation voltage.

The resonance frequency of the antenna circuit can be measured using Probe Test Mode PTx18 (see [Figure 48](#)). After Probe Test Reset, the 6-bit PT Mode (0x18) and the 8-bit Password (0x5A) are shifted into the TMS37157, followed by 131 clock cycles. The measurement phase begins when TEN is taken high, whereupon the TCLK pulse triggers an oscillation in the antenna circuit.

The resulting oscillation will decay at a rate determined by the Q-factor of the antenna circuit, and a clock signal will appear at TDAT as soon as oscillation starts. The measurement time should last at least 10 clock cycles and the average period of one cycle calculated from that. The average resonance frequency is simply the reciprocal of the average resonance period. If longer measurement times are required, the resonance circuit oscillation can be stimulated again with additional TCLK pulses.

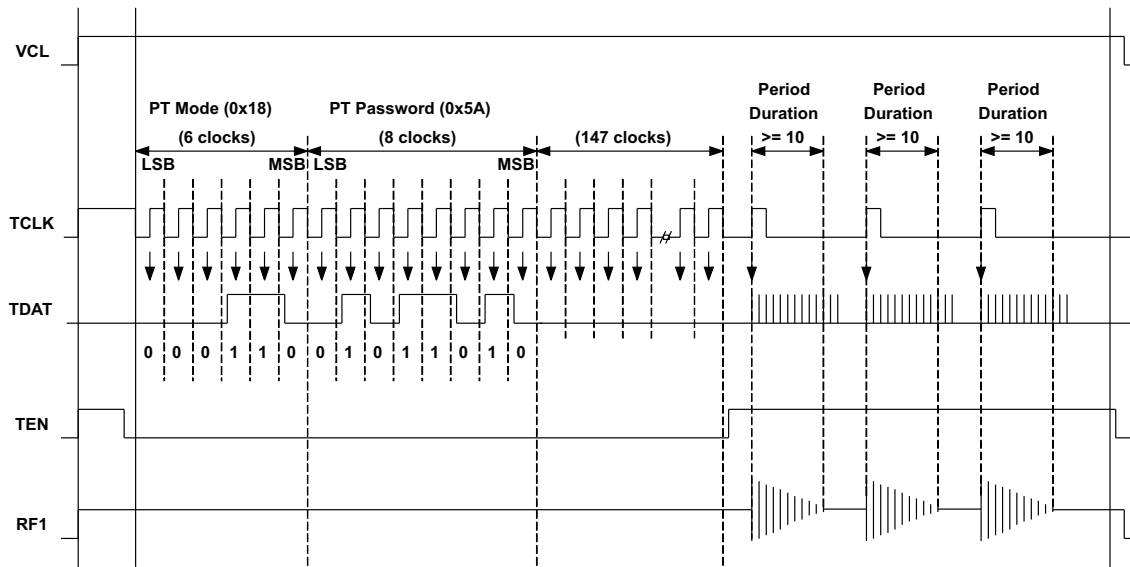

Figure 48. Test Interface Timing – Resonance Frequency Measurement

Trimming EEPROM Programming

The second step in the frequency trimming process is to program the 7-bit trim word in the trimming EEPROM.

The trimming EEPROM can be programmed using Probe Test Mode PTx14 (see Figure 49). After Probe Test Reset, the 6-bit PT Mode (0x14) and the 8-bit Password (0x5A) are shifted into the TMS37157, followed by 8 trim bits. Programming begins when TEN is taken high.

NOTE

Trimming EEPROM Programming requires that 8 trim bits are clocked in, however, only the 7 LSB's after functional – the state of the MSB has no effect.

The result of the programming process should be verified re-measuring the resonance frequency, and the whole process repeated until optimum performance achieved.

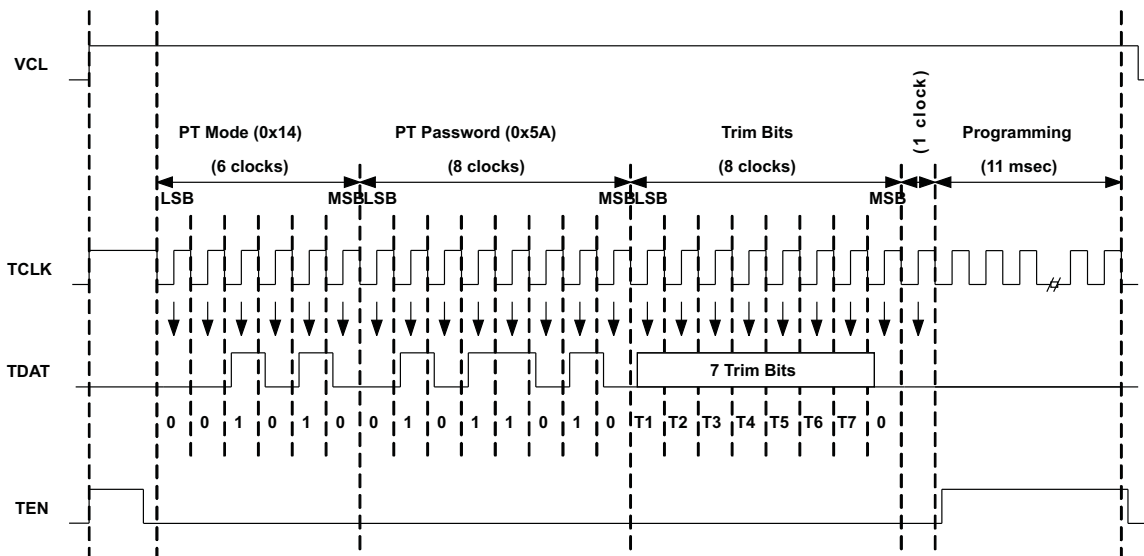

Figure 49. Test Interface Timing – Trimming EEPROM Programming

Modulation Frequency Check

During LF transmissions a FSK signal is transmitted. The resonance frequency of the trimmed antenna circuit (fL) represents a low bit and high bits are represented by a lower frequency (fH), which is achieved by switching in a Modulation Capacitor in parallel with the antenna resonance circuit. This frequency can be measured in the same way as the normal resonance frequency, but using Probe Test Mode 0x16 instead of 0x18.

CRC Calculation

A Cyclic Redundancy Check (CRC) generator is used in the TMS37157 during receipt and transmission of data to generate a 16-Bit Block Check Character (BCC), applying the CRC-CCITT algorithm as shown in Figure 51.

The CRC generator consists of 16 shift register cells with 3 exclusive OR (Xor) Gates. The first Xor gate (X^{16}) combines the input of the CRC generator with the output of the shift register (LSB first) and feeds back to the input of the shift register. The other two Xor gates combine certain cell outputs (X^{12} , X^5) with the output of the first Xor Gate and feed into the next cell input.

The CRC Generator is initialized with the value 0x3791 as shown in Figure 50).

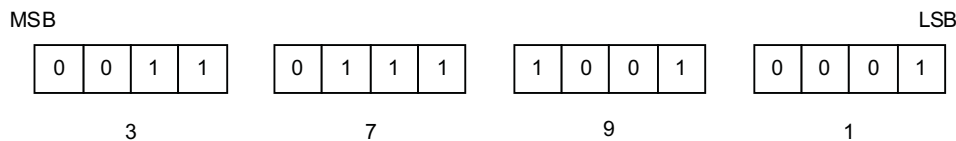

Figure 50. Initial CRC Value 0x3791

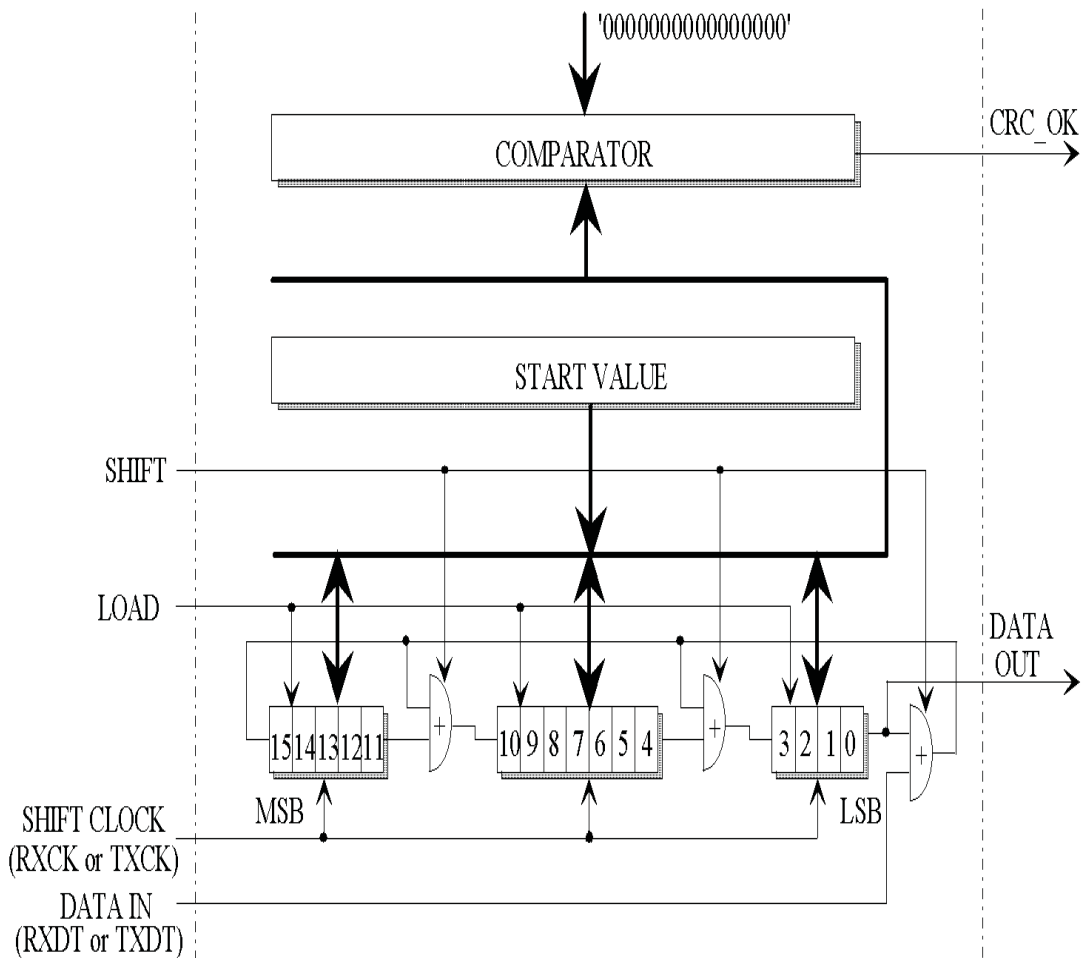

Figure 51. CRC Generator Block Schematic

The CRC generation is started with the first shifted bit, received during write phase RXCK, RXDT. After reception of program or lock command and the additional bits, including the write frame BCC, the CRC Generator content is compared to 0x0000 (CRC_OK).

During read function CRC generation is started after transmission of the start byte (0x7E). After the read data (6 bytes) and the read address byte, the CRC generator content is shifted out using the CRC generator as a normal shift register (SHIFT signal). DATA OUT represents the BCC which is added to read data and read address. The BCC format is one Word with LSB shifted out first.

From a mathematics point of view, the data, which are serially shifted through the CRC generator with LSB first, are multiplied by 16 and divided by the CRC-CCITT generator polynomial:

$$P(X) = X^{16} + X^{12} + X^5 + 1 \tag{1}$$

The remainder from this division is the Read Frame Block Check Character (Read Frame BCC).

The interrogator control unit has to use the same algorithm to generate the Write Frame BCC and to check the Read Frame BCC received from the transponder. The response is checked by shifting the Read Frame BCC through the CRC generator in addition to the received data; the content of the CRC generator must be zero after this action.

Typically the CRC generator is realized in the Base Stations by means of software and not hardware. The algorithm can be handled on a bit-by-bit basis (see Figure 52) or by using look-up tables.

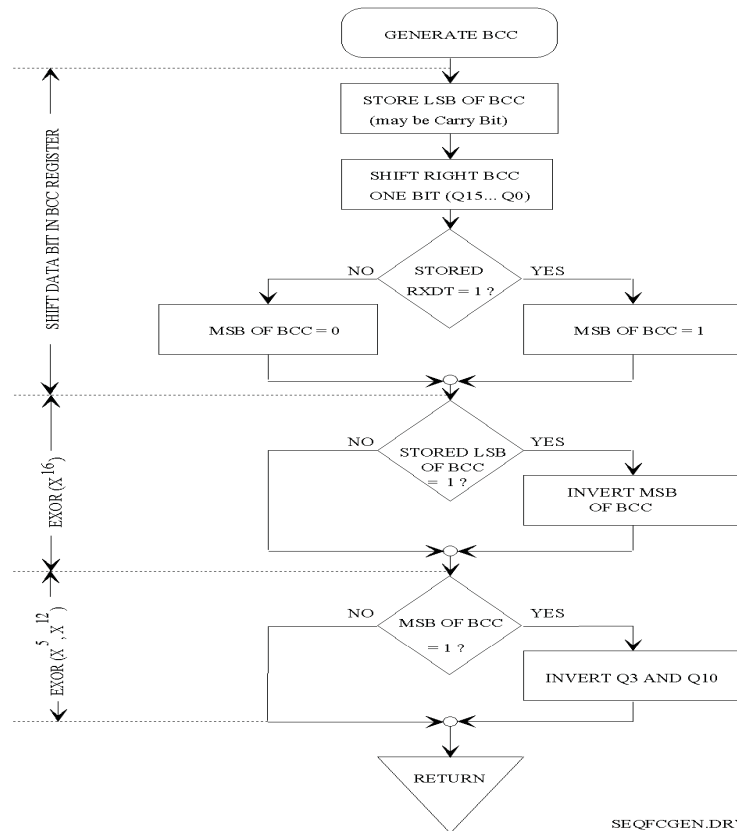

Figure 52. Routine - Generate Block Check Character Bit by Bit

Application Circuit

Only a few additional components are required for using the TMS37157. The recommended application circuits are shown in [Figure 53](#) and [Figure 54](#).

In [Figure 53](#) a typical application of a sensor with a data logger is shown. The Microcontroller is connected to a battery and can wake the TMS37157 to write data into the EEPROM of the TMS37157. The data can be read out through the LF Interface of the TMS37157. This application may also be used for powering the μC out of the RF Field if a battery is not an applicable solution. The battery has to be replaced by a big enough capacitor which is used as a buffer during the LF communication.

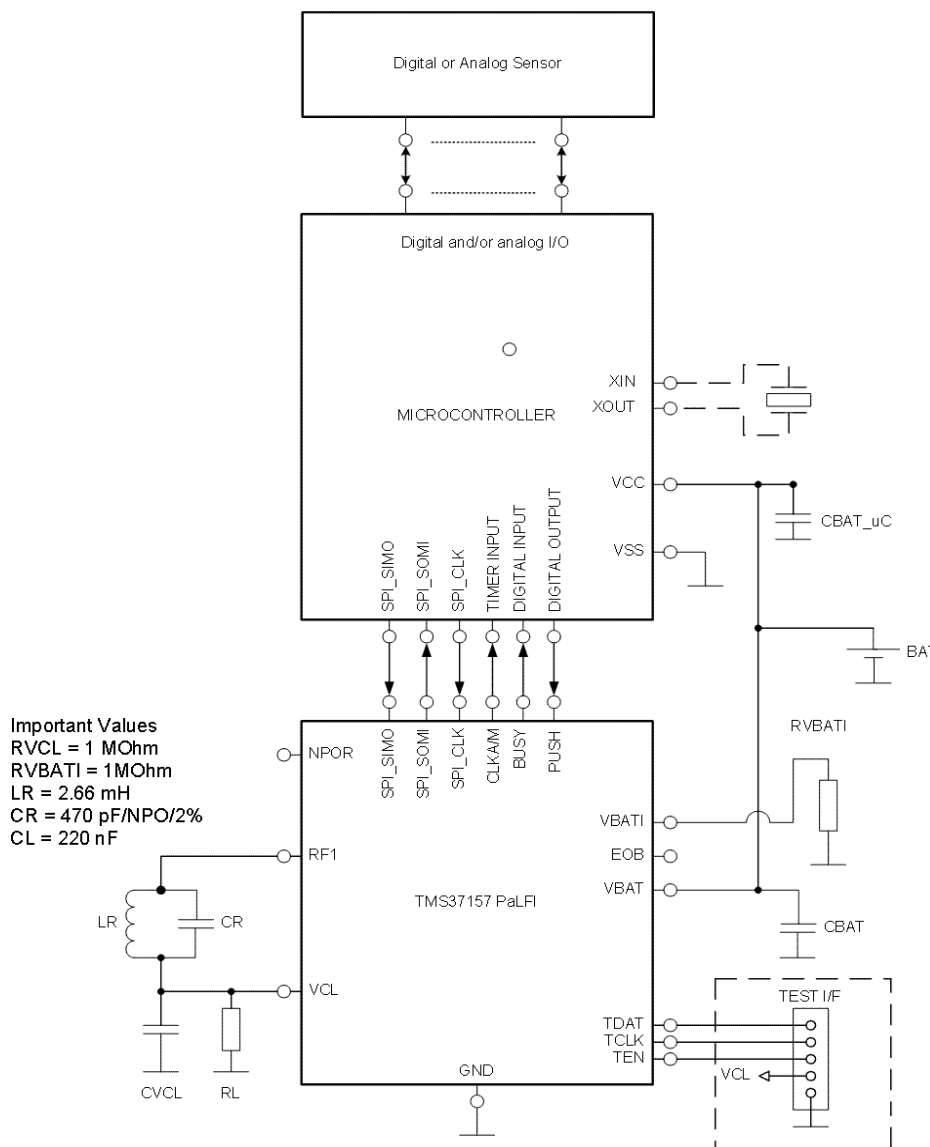

Figure 53. Application Circuit With μC Directly Connected to Battery

In [Figure 54](#) a typical application of a Low Power Sensor with an external interrupt is shown. The μC VCC is connected to the VBATI output. If an external interrupt at Push occurs the TMS37157 initializes and powers up the μC by applying 3 V to VBATI. The μC can perform a measurement store the data in the EEPROM of the TMS37157 and send a power down command to the TMS37157, which switches off VBATI, resulting in an overall power consumption of the whole system of about 60 nA (TMS37157 is in Push Detection Mode).

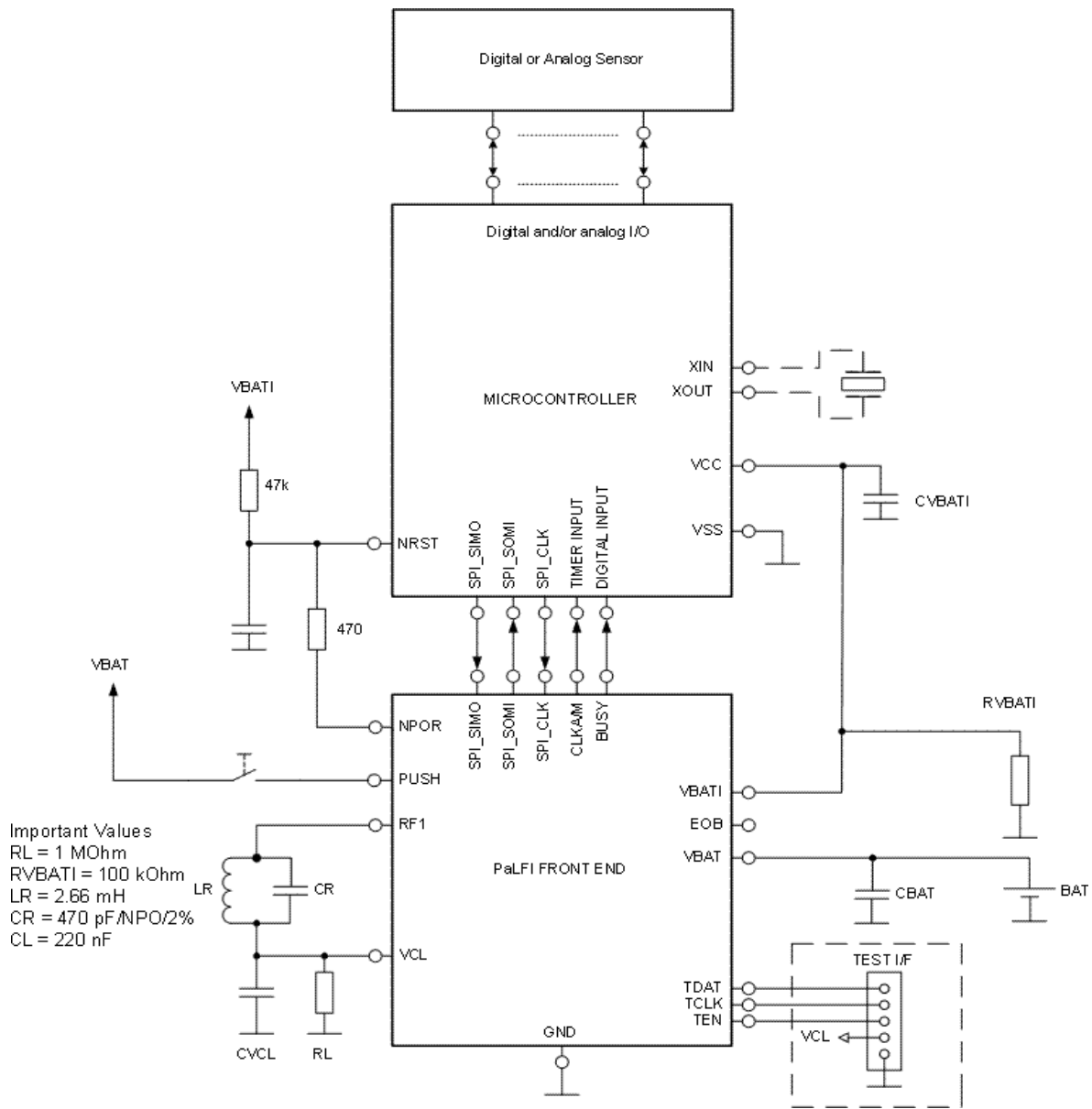

Figure 54. Application Circuit With μ C Connected to VBATI output of TMS37157

PACKAGING INFORMATION

Orderable Device	Status (1)	Package Type	Package Drawing	Pins	Package Qty	Eco Plan (2)	Lead/Ball Finish	MSL Peak Temp (3)	Op Temp (°C)	Top-Side Markings (4)	Samples
TMS37157IRSARG4	ACTIVE	QFN	RSA	16	3000	Green (RoHS & no Sb/Br)	CU NIPDAU	Level-2-260C-1 YEAR	-40 to 85	37157 I	Samples

(1) The marketing status values are defined as follows:

ACTIVE: Product device recommended for new designs.

LIFEBUY: TI has announced that the device will be discontinued, and a lifetime-buy period is in effect.

NRND: Not recommended for new designs. Device is in production to support existing customers, but TI does not recommend using this part in a new design.

PREVIEW: Device has been announced but is not in production. Samples may or may not be available.

OBSOLETE: TI has discontinued the production of the device.

(2) Eco Plan - The planned eco-friendly classification: Pb-Free (RoHS), Pb-Free (RoHS Exempt), or Green (RoHS & no Sb/Br) - please check <http://www.ti.com/productcontent> for the latest availability information and additional product content details.

TBD: The Pb-Free/Green conversion plan has not been defined.

Pb-Free (RoHS): TI's terms "Lead-Free" or "Pb-Free" mean semiconductor products that are compatible with the current RoHS requirements for all 6 substances, including the requirement that lead not exceed 0.1% by weight in homogeneous materials. Where designed to be soldered at high temperatures, TI Pb-Free products are suitable for use in specified lead-free processes.

Pb-Free (RoHS Exempt): This component has a RoHS exemption for either 1) lead-based flip-chip solder bumps used between the die and package, or 2) lead-based die adhesive used between the die and leadframe. The component is otherwise considered Pb-Free (RoHS compatible) as defined above.

Green (RoHS & no Sb/Br): TI defines "Green" to mean Pb-Free (RoHS compatible), and free of Bromine (Br) and Antimony (Sb) based flame retardants (Br or Sb do not exceed 0.1% by weight in homogeneous material)

(3) MSL, Peak Temp. -- The Moisture Sensitivity Level rating according to the JEDEC industry standard classifications, and peak solder temperature.

(4) Multiple Top-Side Markings will be inside parentheses. Only one Top-Side Marking contained in parentheses and separated by a "~" will appear on a device. If a line is indented then it is a continuation of the previous line and the two combined represent the entire Top-Side Marking for that device.

Important Information and Disclaimer: The information provided on this page represents TI's knowledge and belief as of the date that it is provided. TI bases its knowledge and belief on information provided by third parties, and makes no representation or warranty as to the accuracy of such information. Efforts are underway to better integrate information from third parties. TI has taken and continues to take reasonable steps to provide representative and accurate information but may not have conducted destructive testing or chemical analysis on incoming materials and chemicals. TI and TI suppliers consider certain information to be proprietary, and thus CAS numbers and other limited information may not be available for release.

In no event shall TI's liability arising out of such information exceed the total purchase price of the TI part(s) at issue in this document sold by TI to Customer on an annual basis.

TAPE AND REEL INFORMATION



QUADRANT ASSIGNMENTS FOR PIN 1 ORIENTATION IN TAPE



*All dimensions are nominal

Device	Package Type	Package Drawing	Pins	SPQ	Reel Diameter (mm)	Reel Width W1 (mm)	A0 (mm)	B0 (mm)	K0 (mm)	P1 (mm)	W (mm)	Pin1 Quadrant
TMS37157IRSARG4	QFN	RSA	16	3000	330.0	12.4	4.25	4.25	1.15	8.0	12.0	Q2

TAPE AND REEL BOX DIMENSIONS

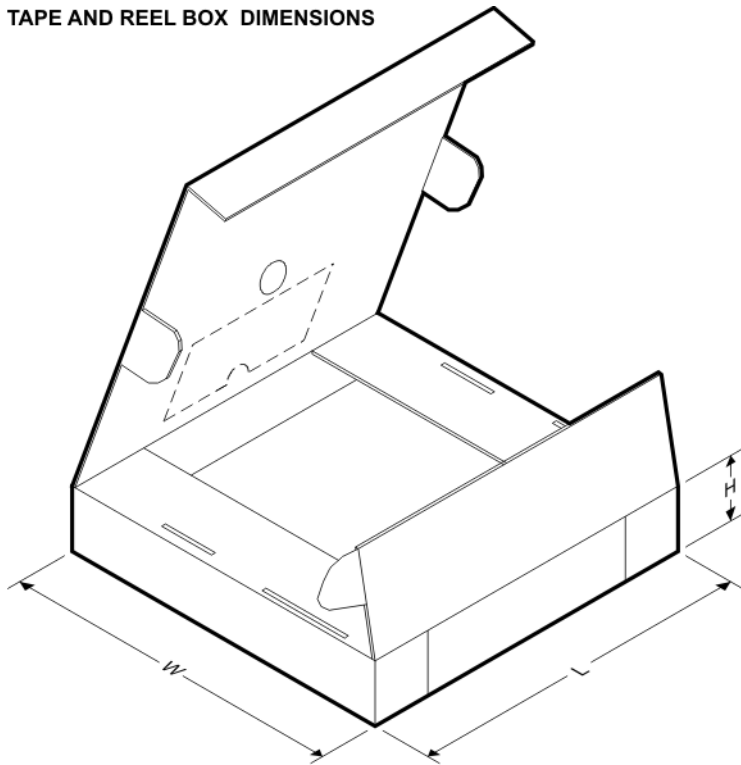

*All dimensions are nominal

Device	Package Type	Package Drawing	Pins	SPQ	Length (mm)	Width (mm)	Height (mm)
TMS37157IRSARG4	QFN	RSA	16	3000	367.0	367.0	35.0

RSA (S-PVQFN-N16)

PLASTIC QUAD FLATPACK NO-LEAD

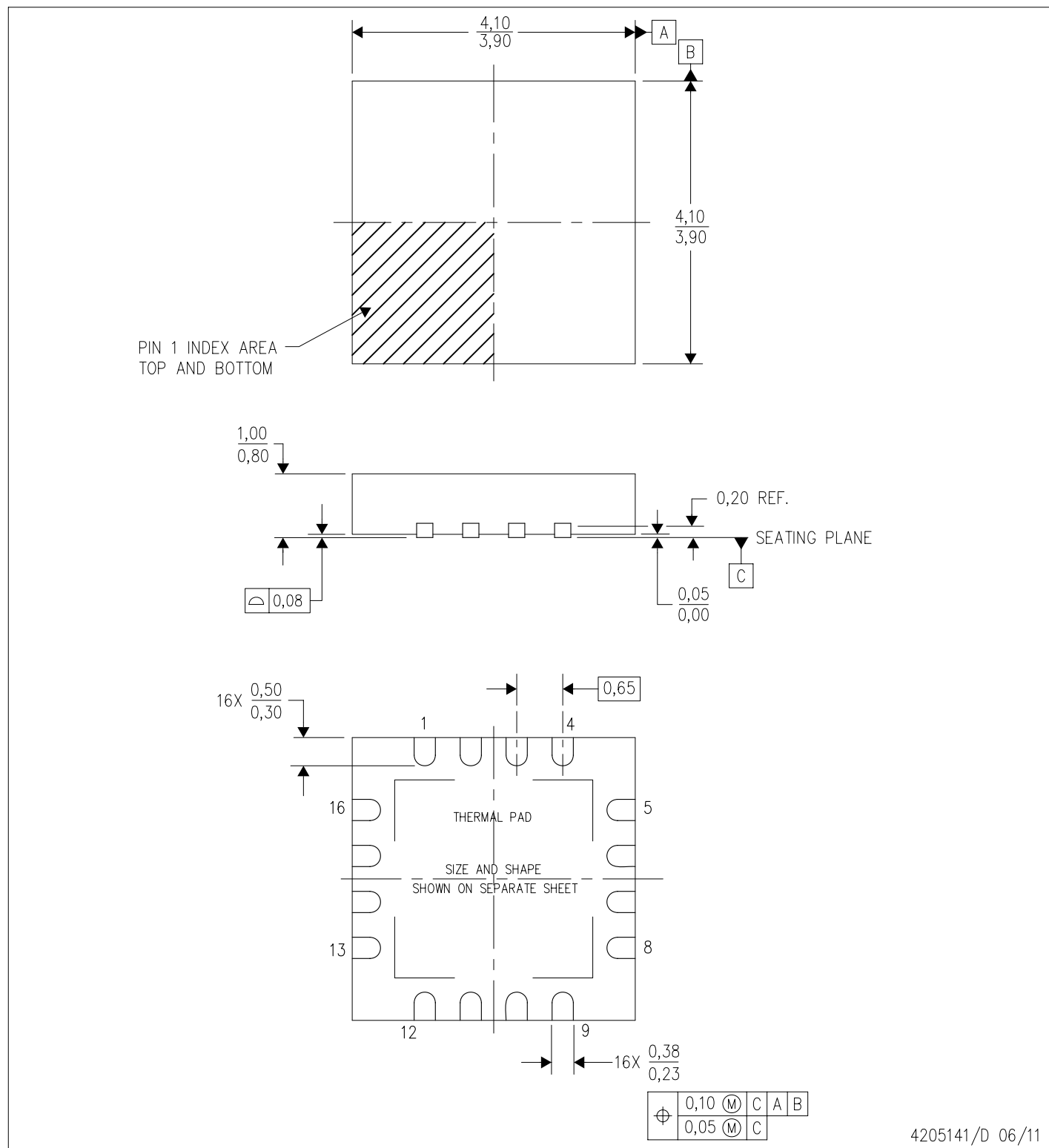

- NOTES:
- All linear dimensions are in millimeters. Dimensioning and tolerancing per ASME Y14.5M-1994.
 - This drawing is subject to change without notice.
 - Quad Flatpack, No-leads (QFN) package configuration.
 - The package thermal pad must be soldered to the board for thermal and mechanical performance.
 - See the additional figure in the Product Data Sheet for details regarding the exposed thermal pad features and dimensions.
 - Falls within JEDEC MO-220.

THERMAL INFORMATION

This package incorporates an exposed thermal pad that is designed to be attached directly to an external heatsink. The thermal pad must be soldered directly to the printed circuit board (PCB). After soldering, the PCB can be used as a heatsink. In addition, through the use of thermal vias, the thermal pad can be attached directly to the appropriate copper plane shown in the electrical schematic for the device, or alternatively, can be attached to a special heatsink structure designed into the PCB. This design optimizes the heat transfer from the integrated circuit (IC).

For information on the Quad Flatpack No-Lead (QFN) package and its advantages, refer to Application Report, QFN/SON PCB Attachment, Texas Instruments Literature No. SLUA271. This document is available at www.ti.com.

The exposed thermal pad dimensions for this package are shown in the following illustration.

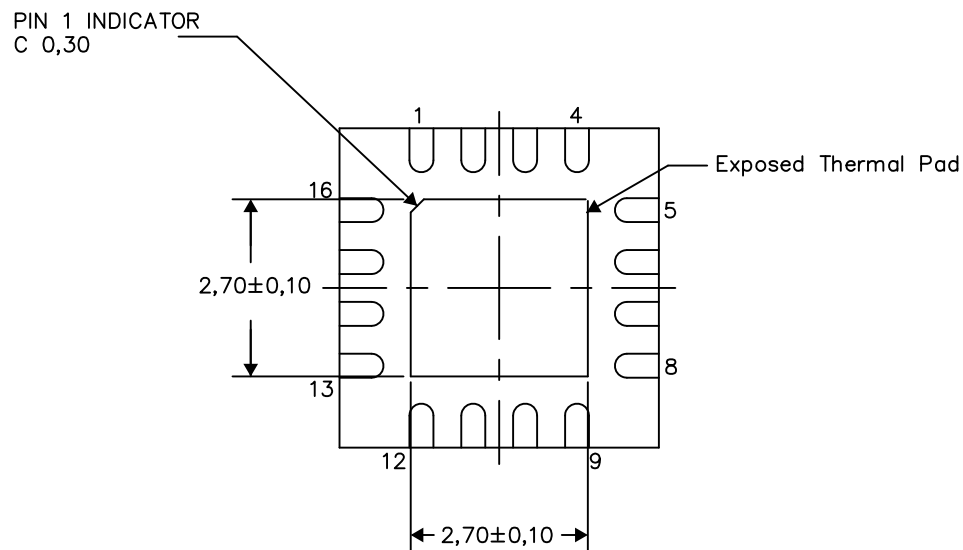

Bottom View

Exposed Thermal Pad Dimensions

4206364/N 07/13

NOTES:

A. All linear dimensions are in millimeters

RSA (S-PVQFN-N16)

PLASTIC QUAD FLATPACK NO-LEAD

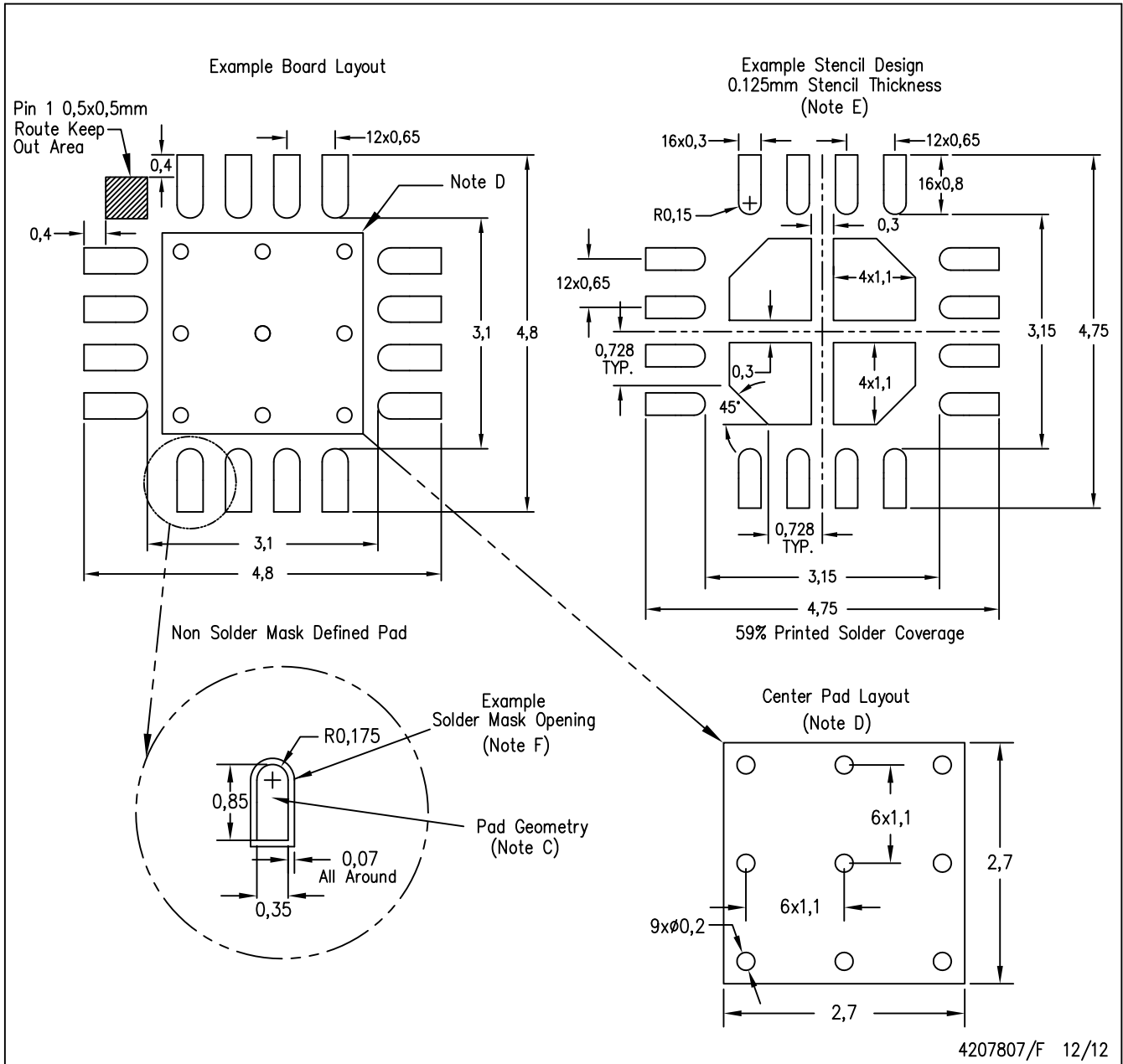

4207807/F 12/12

- NOTES:
- A. All linear dimensions are in millimeters.
 - B. This drawing is subject to change without notice.
 - C. Publication IPC-7351 is recommended for alternate designs.
 - D. This package is designed to be soldered to a thermal pad on the board. Refer to Application Note, QFN Packages, Texas Instruments Literature No. SLUA271, and also the Product Data Sheets for specific thermal information, via requirements, and recommended board layout. These documents are available at www.ti.com <<http://www.ti.com>>.
 - E. Laser cutting apertures with trapezoidal walls and also rounding corners will offer better paste release. Customers should contact their board assembly site for stencil design recommendations. Refer to IPC 7525 for stencil design considerations.
 - F. Customers should contact their board fabrication site for solder mask tolerances.

IMPORTANT NOTICE

Texas Instruments Incorporated and its subsidiaries (TI) reserve the right to make corrections, enhancements, improvements and other changes to its semiconductor products and services per JESD46, latest issue, and to discontinue any product or service per JESD48, latest issue. Buyers should obtain the latest relevant information before placing orders and should verify that such information is current and complete. All semiconductor products (also referred to herein as "components") are sold subject to TI's terms and conditions of sale supplied at the time of order acknowledgment.

TI warrants performance of its components to the specifications applicable at the time of sale, in accordance with the warranty in TI's terms and conditions of sale of semiconductor products. Testing and other quality control techniques are used to the extent TI deems necessary to support this warranty. Except where mandated by applicable law, testing of all parameters of each component is not necessarily performed.

TI assumes no liability for applications assistance or the design of Buyers' products. Buyers are responsible for their products and applications using TI components. To minimize the risks associated with Buyers' products and applications, Buyers should provide adequate design and operating safeguards.

TI does not warrant or represent that any license, either express or implied, is granted under any patent right, copyright, mask work right, or other intellectual property right relating to any combination, machine, or process in which TI components or services are used. Information published by TI regarding third-party products or services does not constitute a license to use such products or services or a warranty or endorsement thereof. Use of such information may require a license from a third party under the patents or other intellectual property of the third party, or a license from TI under the patents or other intellectual property of TI.

Reproduction of significant portions of TI information in TI data books or data sheets is permissible only if reproduction is without alteration and is accompanied by all associated warranties, conditions, limitations, and notices. TI is not responsible or liable for such altered documentation. Information of third parties may be subject to additional restrictions.

Resale of TI components or services with statements different from or beyond the parameters stated by TI for that component or service voids all express and any implied warranties for the associated TI component or service and is an unfair and deceptive business practice. TI is not responsible or liable for any such statements.

Buyer acknowledges and agrees that it is solely responsible for compliance with all legal, regulatory and safety-related requirements concerning its products, and any use of TI components in its applications, notwithstanding any applications-related information or support that may be provided by TI. Buyer represents and agrees that it has all the necessary expertise to create and implement safeguards which anticipate dangerous consequences of failures, monitor failures and their consequences, lessen the likelihood of failures that might cause harm and take appropriate remedial actions. Buyer will fully indemnify TI and its representatives against any damages arising out of the use of any TI components in safety-critical applications.

In some cases, TI components may be promoted specifically to facilitate safety-related applications. With such components, TI's goal is to help enable customers to design and create their own end-product solutions that meet applicable functional safety standards and requirements. Nonetheless, such components are subject to these terms.

No TI components are authorized for use in FDA Class III (or similar life-critical medical equipment) unless authorized officers of the parties have executed a special agreement specifically governing such use.

Only those TI components which TI has specifically designated as military grade or "enhanced plastic" are designed and intended for use in military/aerospace applications or environments. Buyer acknowledges and agrees that any military or aerospace use of TI components which have **not** been so designated is solely at the Buyer's risk, and that Buyer is solely responsible for compliance with all legal and regulatory requirements in connection with such use.

TI has specifically designated certain components as meeting ISO/TS16949 requirements, mainly for automotive use. In any case of use of non-designated products, TI will not be responsible for any failure to meet ISO/TS16949.

Products

Audio	www.ti.com/audio
Amplifiers	amplifier.ti.com
Data Converters	dataconverter.ti.com
DLP® Products	www.dlp.com
DSP	dsp.ti.com
Clocks and Timers	www.ti.com/clocks
Interface	interface.ti.com
Logic	logic.ti.com
Power Mgmt	power.ti.com
Microcontrollers	microcontroller.ti.com
RFID	www.ti-rfid.com
OMAP Applications Processors	www.ti.com/omap
Wireless Connectivity	www.ti.com/wirelessconnectivity

Applications

Automotive and Transportation	www.ti.com/automotive
Communications and Telecom	www.ti.com/communications
Computers and Peripherals	www.ti.com/computers
Consumer Electronics	www.ti.com/consumer-apps
Energy and Lighting	www.ti.com/energy
Industrial	www.ti.com/industrial
Medical	www.ti.com/medical
Security	www.ti.com/security
Space, Avionics and Defense	www.ti.com/space-avionics-defense
Video and Imaging	www.ti.com/video

TI E2E Community

e2e.ti.com

Looking for pricing, stock, or lifecycle information?

Click below to explore more details on WIN SOURCE:

 [View TMS37157IRSARG4 on WIN SOURCE](#)

 [Texas Instruments](#) Information

Optimize Your Supply Chain with WIN SOURCE Solutions

-  Global Sourcing Solution
-  Obsolete Management
-  Cost Control Management
-  Shortage Management
-  Alternative Solution
-  Excess Inventory Management