



THE DATASHEET OF TDA7451





TDA7451

4x7W OR 2x22W CAR RADIO POWER AMPLIFIER PLUS TRIPLE POWER SUPPLY

PRELIMINARY DATA

- HIGH OUTPUT POWER CAPABILITY:
 - 4 x 9.5W OR 2 x 32W/4Ω MAX
 - 4 x 8.5W OR 2 x 28W/4Ω EIAJ
 - 4 x 7W OR 2 x 22W/4Ω @14.4V, 1KHz; 10%
- MINIMIZED EXTERNAL COUNT
 - NO NEED OF DECOUPLING CAPACITORS
 - NO NEED OF BOOTSTRAP CAPACITOR
 - NO NEED OF EXTERNAL COMPENSATION
 - INTERNALLY FIXED GAIN (20dB)
- POP-FREE AUDIO SECTION
- ST-BY FUNCTION (C-MOS)
- MUTE FUNCTION (C-MOS)
- CLIP DETECTOR, THERMAL WARNING, SHORT CIRCUIT DETECTION
- BUILT-IN VOLTAGE REGULATORS:
 - 5V @ 150mA WITH RESET
 - 5V @ 500mA WITH ST-BY
 - 8.5V @ 200mA WITH ST-BY
- REGULATORS DIAGNOSTIC FEATURE: UNDERVOLTAGE, 8.5V DROP SENSE, SHORT CIRCUIT, LOAD DUMP, OVER-TEMPERATURE

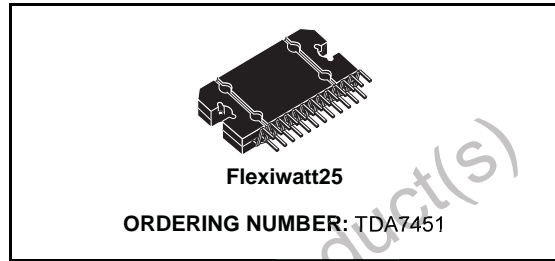

TURE

PROTECTIONS

General:

- LOAD DUMP
- OVERRATING CHIP TEMPERATURE

Audio Section:

- OUT SHORT (TO GND, TO Vs AND ACROSS THE LOAD)

Power Supply Section:

- SHORT CIRCUIT PROTECTION (OUT TO GND)

BLOCK DIAGRAM

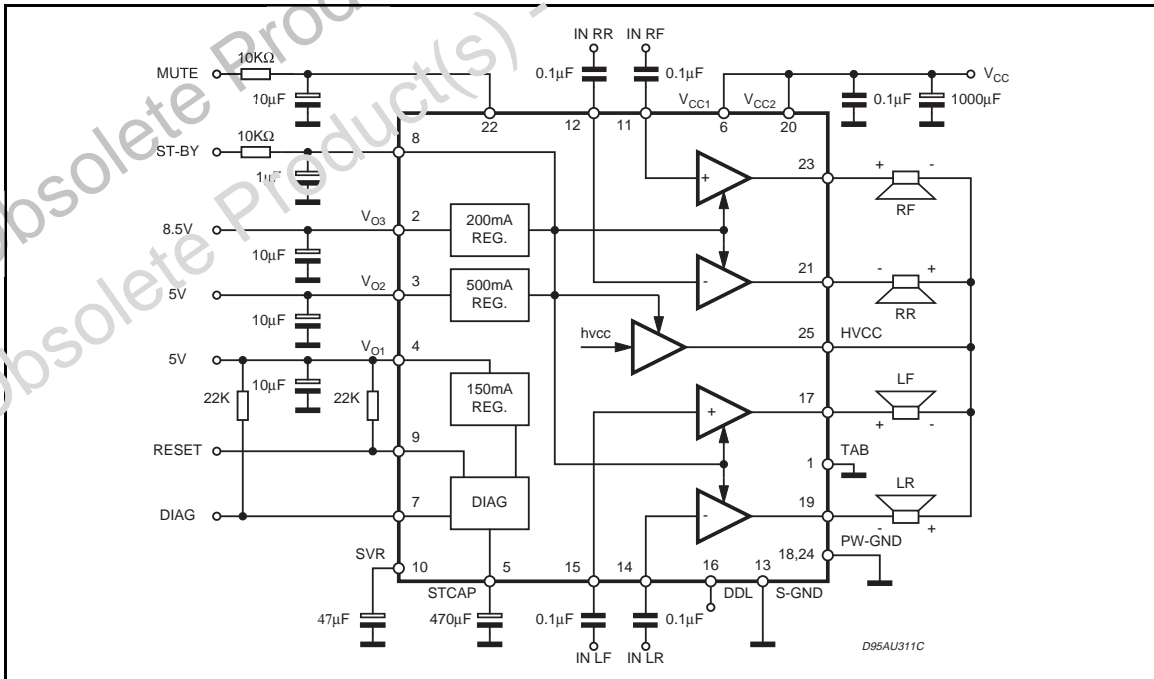

TDA7451

ABSOLUTE MAXIMUM RATINGS

Symbol	Parameter	Value	Unit
V_S	Operating Supply Voltage	18	V
V_S	DC Supply Voltage	28	V
V_S	Peak Supply Voltage (t = 50ms)	40	V
I_o	Audio Output Peak Current (non repetitive t = 100 μ s)	4	A
	Audio Output Peak Current (repetitive f > 10Hz)	3	A
I_o	Voltage Regulators Output Current	internally limited	
P_{tot}	Power Dissipation at $T_{case} = 85^\circ\text{C}$	55	W
T_{stg}, T_j	Storage and Junction Temperature Range	-40 to 150	$^\circ\text{C}$
V_{out}	Output Voltages (DIAG, RESET)	7	V
V_{in}	Input Voltages (ST-BY, MUTE)	18	V
RESR	Output capacitor series resistance	0.2 to 10	Ω

PIN CONNECTION

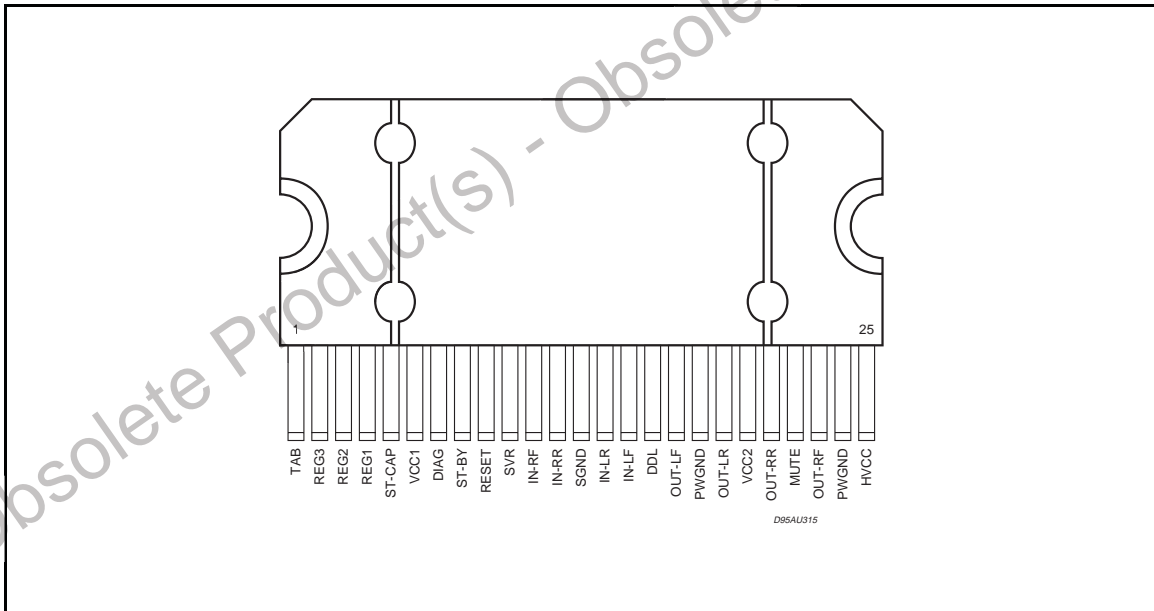

THERMAL DATA

Symbol	Parameter	Value	Unit
$R_{th\ j-case}$	Thermal Resistance Junction-case	1.2	$^\circ\text{C}/\text{W}$

P_O = 4 X 7W S.E. APPLICATION

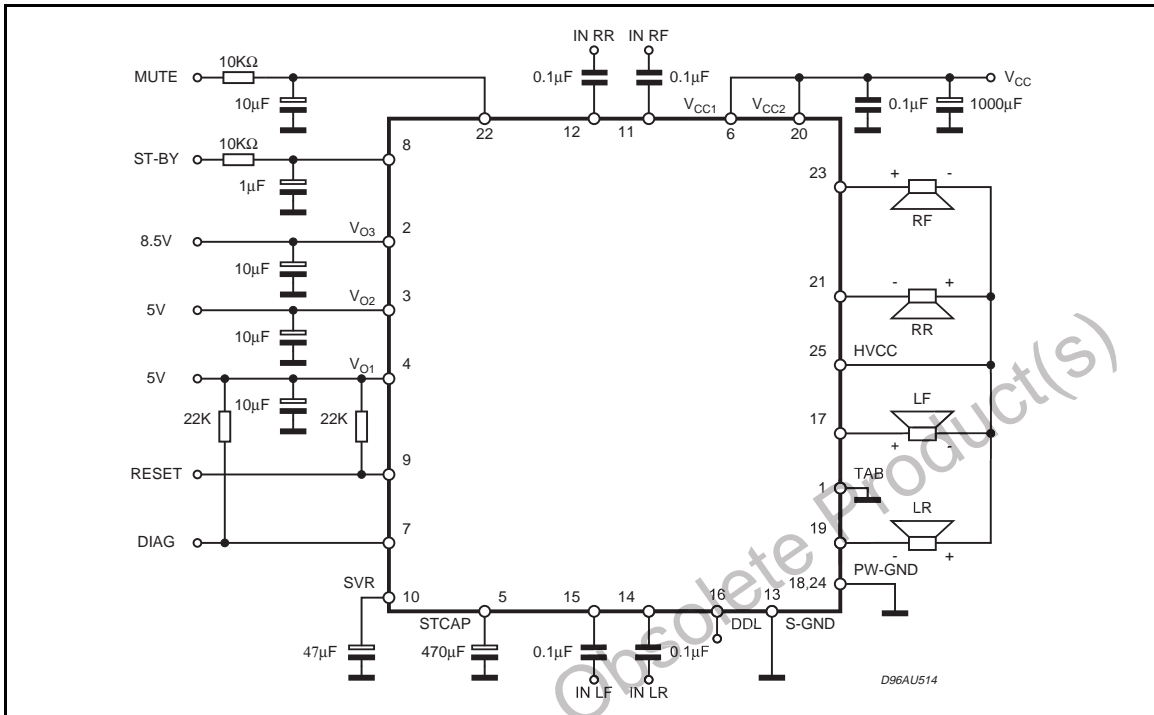

P_O = 2 X 22W BTL APPLICATION

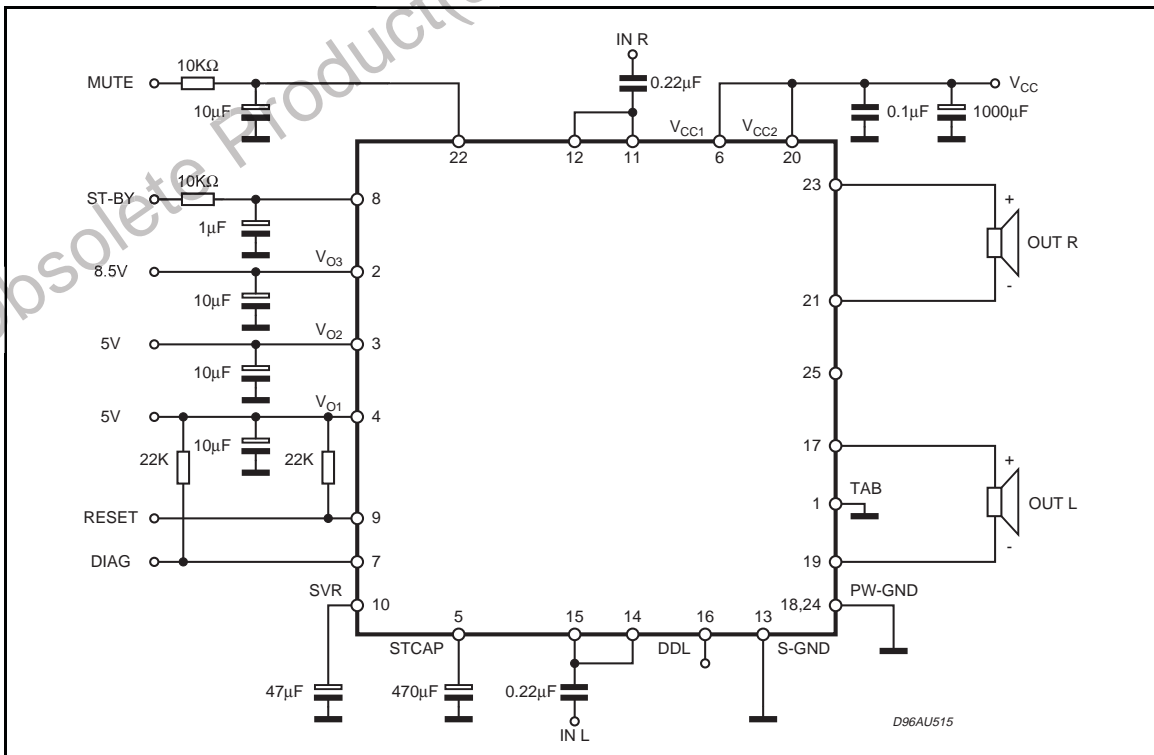

TDA7451

ELECTRICAL CHARACTERISTICS (Refer to the test circuit; $V_S = 14.4V$; $R_L = 4\Omega$, $T_{amb} = 25^\circ C$, $f = 1kHz$, unless otherwise specified)

Symbol	Parameter	Test Condition	Min.	Typ.	Max.	Unit
GENERAL						
I_q	Total Quiescent Current	$I_{L01}, I_{L02}, I_{L03} = 5mA$		80	150	mA
$V_{SB\ IN}$	ST-BY IN Threshold Voltage				1.5	V
$V_{SB\ OUT}$	ST-BY OUT Threshold Voltage		3.5			V
I_{ST-BY}	Stand-by Current Consumption	$I_{L01} = 2mA$			0.5	mA
AUDIO SECTION						
P_O	Output Power	$R_L = 4\Omega$; THD = 10% Bridge Single Ended	19 6	22 7		W W
$P_{O\ EIAJ}$	EIAJ Output Power (**)	$V_S = 13.7V$ Bridge Single Ended	26 7.5	28 8.5		W W
$P_{O\ max.}$	Max. Output Power (**)	$V_S = 14.4V$ Bridge Single Ended	30 8	32 9.5		W W
d	Distortion	$R_L = 4\Omega$; Single Ended, $P_O = 0.1$ to 3W Bridge, $P_O = 0.1$ to 8W		0.04 0.06	0.3 0.3	% %
CT	Cross Talk	$f = 1kHz$; $R_g = 0$ $f = 10kHz$; $R_g = 0$	50	60 55		dB dB
R_{IN}	Input Impedance	Single Ended Bridge	70 35	100 50	130 65	$K\Omega$ $K\Omega$
G_V	Voltage Gain	Single Ended Bridge	19 25	20 26	21 27	dB dB
G_V	Voltage Gain Match.				1	dB
BW	Bandwidth	-3dB	100			KHz
E_{NO}	Output Noise Voltage (*)	$R_g = 0$; Single Ended		100		μV
SVR	Supply Voltage Rejection	$R_g = 0$; $f = 100Hz$; Single Ended	48	55		dB
ASB	Stand-by Attenuation		90	100		dB
$I_{PIN\ 8}$	ST-BY Pin Current	Play mode; $V_{pin8} = 5V$	-10		30	μA
A_M	MUTE Attenuation		80	90		dB
$V_{M\ IN}$	MUTE IN Threshold Voltage				1.5	V
$V_{M\ OUT}$	MUTE OUT Threshold Voltage		3.5			V
I_{CD}	Clipping Detector Current (Pull up to 5V with 10K Ω)	CDoff: $P_{Omin} = 3.5W$ CDon: THD = 5%			5	μA
			50	190	280	μA
POWER SUPPLY SECTION						
V_{O1}	Output Voltages	$I_{O1} = 5mA$	4.85	5	5.15	V
ΔV_{O1}	Load Regulation 1	$I_{O1} = 5$ to 150mA			80	mV
I_{L01}	Current Limit	$V_{O1} = 0V$	250	350	600	mA
ΔV_{O1}	Dropout Voltages	$I_{O1} = 150mA$			700	mV
SVR	Ripple Rejection	$V_{ripple} = 1V_{pp}$; $I_{O1} = 50mA$ $f = 100Hz$ $f = 10KHz$	60 50			dB dB
ΔV_{O1}	Line Regulation 1	$V_S = 8$ to 18V; $I_{O1} = 5mA$		10	40	mV
RESET						
Reset On	Low V_{REG1} Reset On Threshold		3.5	4.0	4.7	V
Reset Off	Low V_{REG1} Reset Off Threshold			4.25		V
Reset Hyst	Reset Threshold Hysteresis vs Reg 1			250	500	mV
$V_{out\ on\ Reset}$	Reset Output Voltage	Reset activated $R(Reset\ to\ V_{Reg1}) \geq 15K$			1.5	V

(*) 22Hz to 22KHz

ELECTRICAL CHARACTERISTICS (continued)

Symbol	Parameter	Test Condition	Min.	Typ.	Max.	Unit
DIAGNOSTIC OUTPUT						
Diag On Vs	Low Vs Diag. ON Threshold		7	7.5	8	V
Diag Off Vs	Low Vs Diag. OFF Threshold			7.6		V
Diag Hyst Vs	Low Vs Diag. Hysteresis			100	150	mV
Diag Dump	Diag. Threshold vs Overvoltage		20	21	22	V
Diag On Drop	V _{REG3} Output Voltage Drop Before Diag. Activation	I _{O3} = 100mA		90	200	mV
V _{out} On Diag	Diag. Output Voltage	Diag activated R (Diag to V _{REG1}) ≥ 15K			1.5	V
V _{O2}	Output Voltage 2	I _{O2} = 5mA	4.85	5	5.15	V
ΔV _{O2}	Load Regulation 2	I _{O2} = 5 to 500mA			100	mV
I _{L02}	Current Limit 2	V _{O2} = 0V	0.8	1	1.5	A
ΔV _{O2}	Dropout Voltage	I _{O2} = 500mA		1	1.5	V
SVR	Ripple Rejection	V _{ripple} = 1Vpp; I _{O2} = 100mA f = 100Hz f = 10KHz	60 50			dB dB
ΔV _{O2}	Line Regulation	V _S = 8 to 18V, I _{O2} = 5mA		10	40	mV
V _{O3}	Output Voltage 3	I _{O3} = 5mA	8.25	8.5	8.75	V
ΔV _{O3}	Load Regulation 3	I _{O3} = 5 to 200mA			80	mV
I _{L03}	Current Limit 3		300	400	800	mA
ΔV _{O3}	Dropout Voltage	I _{O3} = 200mA			1	V
SVR	Ripple Rejection	V _{ripple} = 1Vpp; I _{O3} = 100mA f = 100Hz f = 10KHz	60 50			dB dB
ΔV _{O3}	Line Regulation 3	V _S = 11 to 18V, I _{O3} = 5mA		10	40	mV

DIAGNOSTIC DIAGRAM

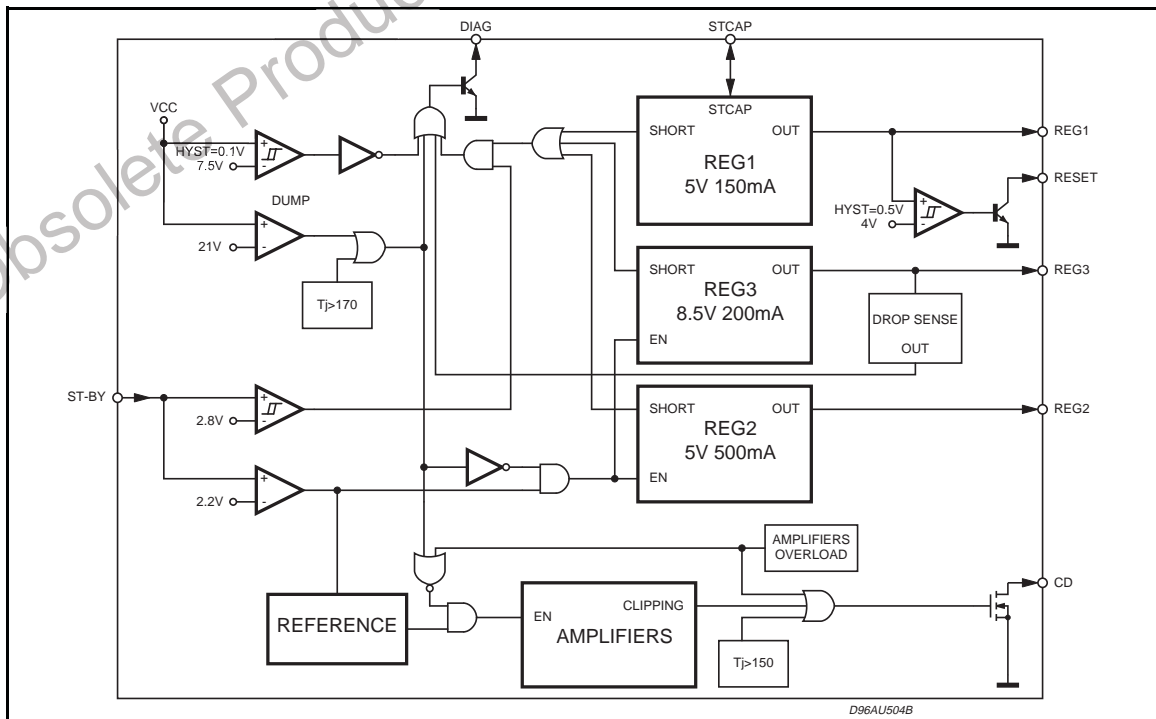

VOLTAGE SUPPLY SECTION WAVEFORMS

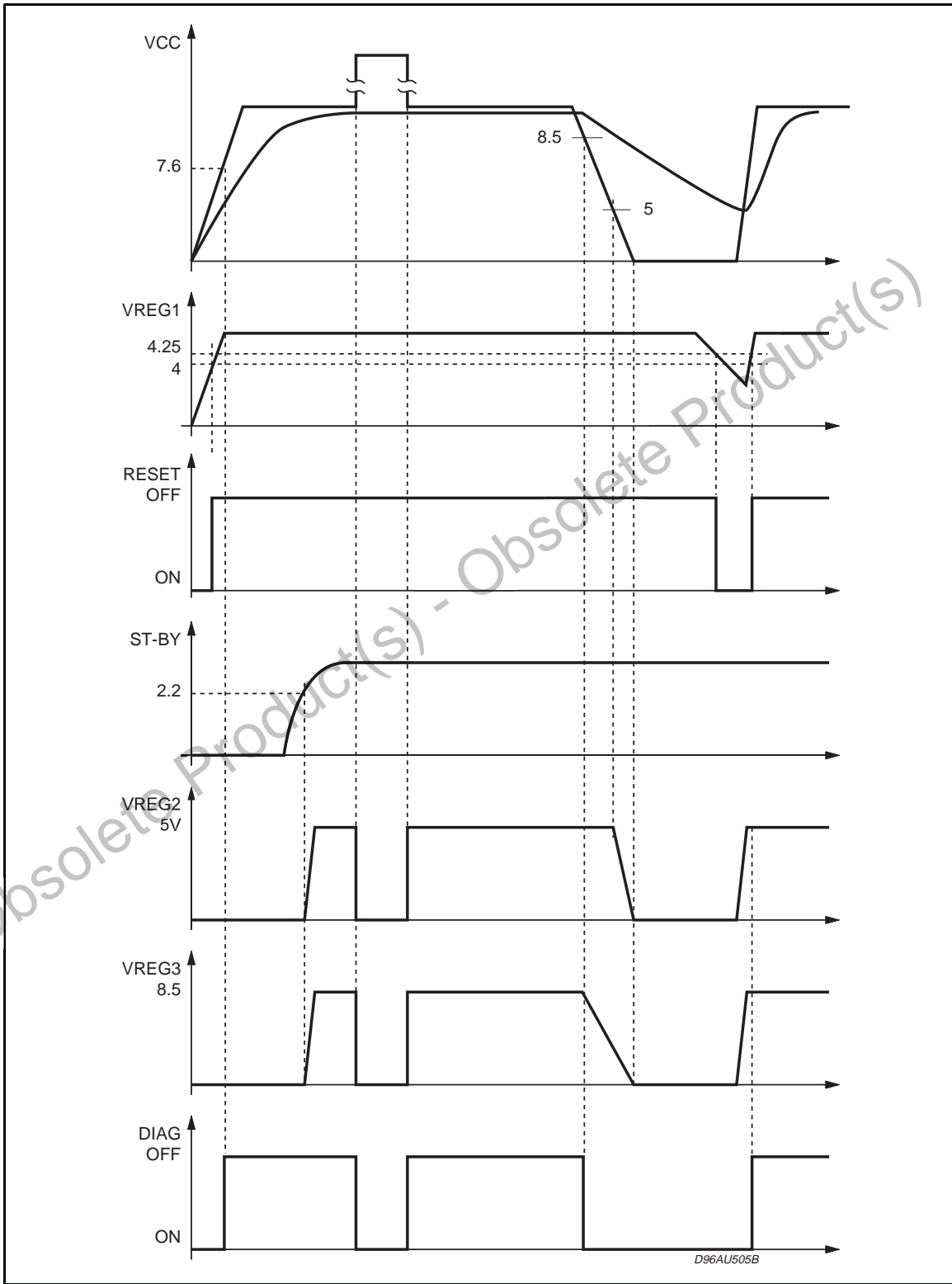

AUDIO SECTION WAVEFORMS

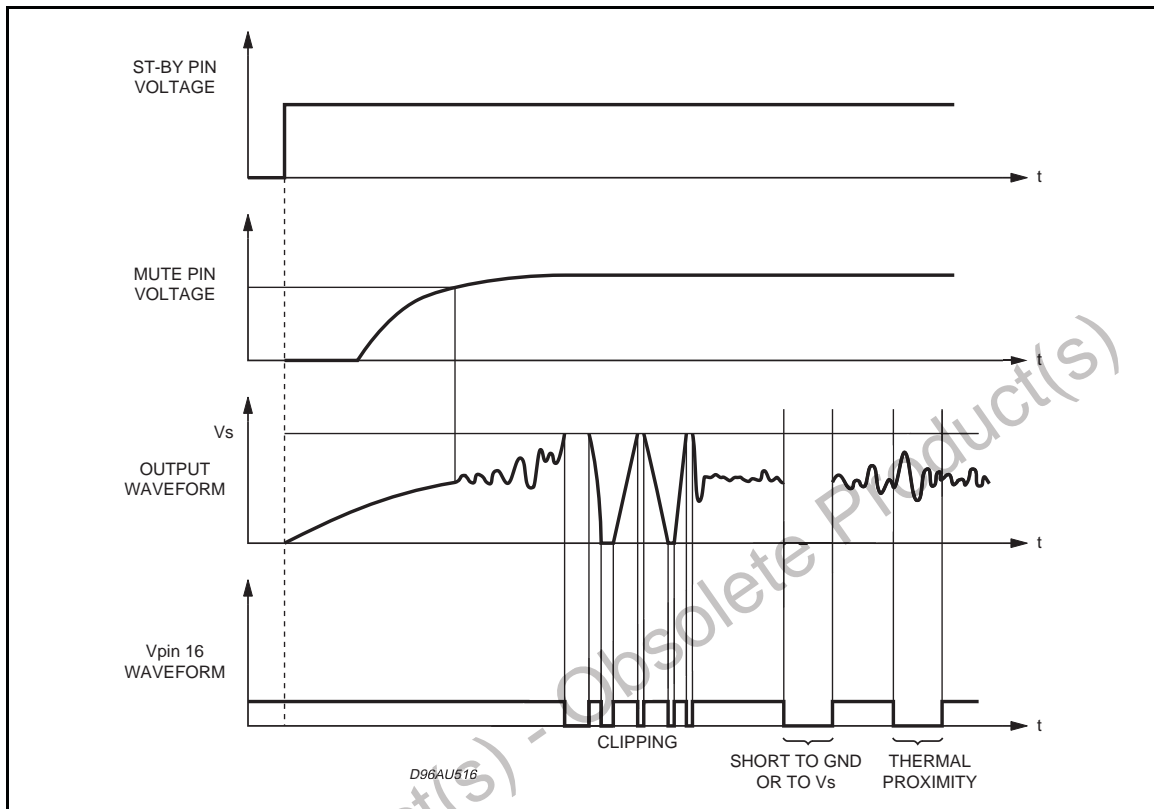

TDA7451

DIM.	mm			inch		
	MIN.	TYP.	MAX.	MIN.	TYP.	MAX.
A	4.45	4.50	4.65	0.175	0.177	0.183
B	1.80	1.90	2.00	0.070	0.074	0.079
C		1.40			0.055	
D	0.75	0.90	1.05	0.029	0.035	0.041
E	0.37	0.39	0.42	0.014	0.015	0.016
F (1)			0.57			0.022
G	0.80	1.00	1.20	0.031	0.040	0.047
G1	23.75	24.00	24.25	0.935	0.945	0.955
H (2)	28.90	29.23	29.30	1.138	1.150	1.153
H1		17.00			0.669	
H2		12.80			0.503	
H3		0.80			0.031	
L (2)	22.07	22.47	22.87	0.869	0.884	0.904
L1	18.57	18.97	19.37	0.731	0.747	0.762
L2 (2)	15.50	15.70	15.90	0.610	0.618	0.626
L3	7.70	7.85	7.95	0.303	0.309	0.313
L4		5			0.197	
L5		3.5			0.138	
M	3.70	4.00	4.30	0.145	0.157	0.169
M1	3.60	4.00	4.40	0.142	0.157	0.173
N		2.20			0.086	
O		2			0.079	
R		1.70			0.067	
R1		0.5			0.02	
R2		0.3			0.12	
R3		1.25			0.049	
R4		0.50			0.019	
V			5° (Typ.)			
V1			3° (Typ.)			
V2			20° (Typ.)			
V3			45° (Typ.)			

(1): dam-bar protusion not included
 (2): molding protusion included

OUTLINE AND MECHANICAL DATA

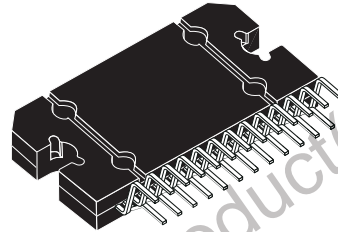

Flexiwatt25

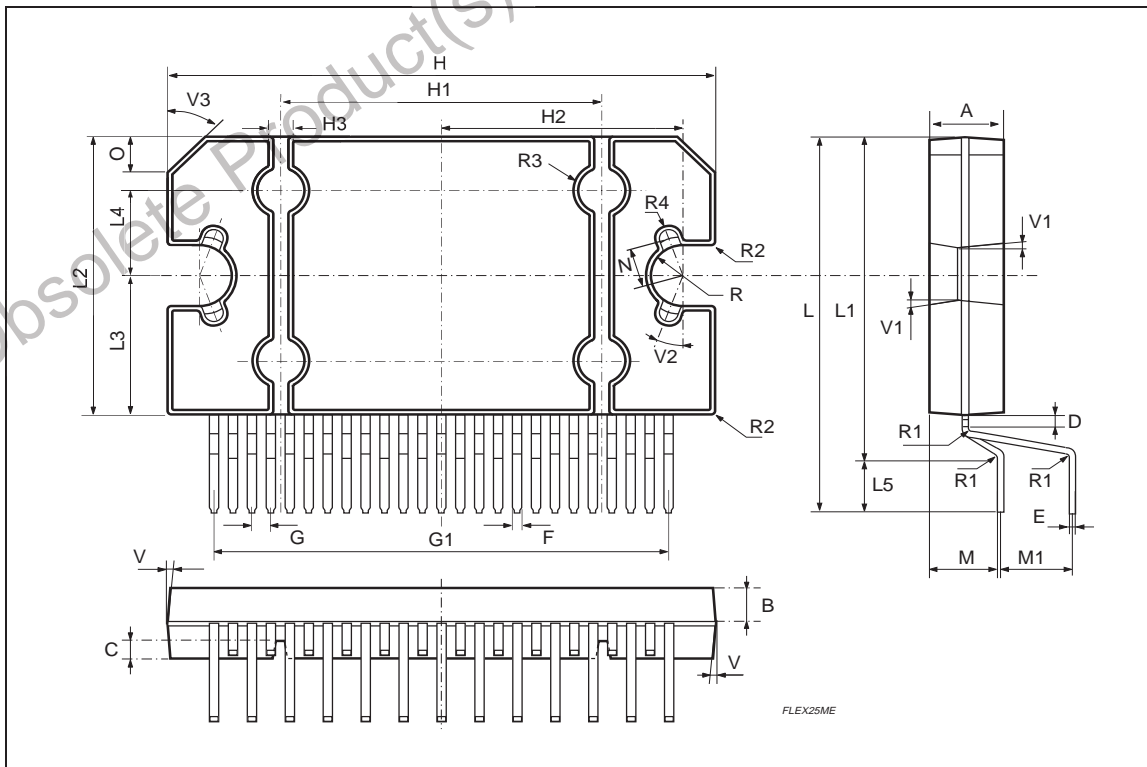

Obsolete Product(s) - Obsolete Product(s)

Information furnished is believed to be accurate and reliable. However, STMicroelectronics assumes no responsibility for the consequences of use of such information nor for any infringement of patents or other rights of third parties which may result from its use. No license is granted by implication or otherwise under any patent or patent rights of STMicroelectronics. Specification mentioned in this publication are subject to change without notice. This publication supersedes and replaces all information previously supplied. STMicroelectronics products are not authorized for use as critical components in life support devices or systems without express written approval of STMicroelectronics.

The ST logo is a registered trademark of STMicroelectronics

© 1999 STMicroelectronics - Printed in Italy - All Rights Reserved



STMicroelectronics GROUP OF COMPANIES

Australia - Brazil - China - Finland - France - Germany - Hong Kong - India - Italy - Japan - Malaysia - Malta - Morocco -
Singapore - Spain - Sweden - Switzerland - United Kingdom - U.S.A.

<http://www.st.com>

Looking for pricing, stock, or lifecycle information?

Click below to explore more details on WIN SOURCE:

-  [View TDA7451](#) on WIN SOURCE
-  [STMicroelectronics](#) Information

Optimize Your Supply Chain with WIN SOURCE Solutions

-  Global Sourcing Solution
-  Obsolete Management
-  Cost Control Management
-  Shortage Management
-  Alternative Solution
-  Excess Inventory Management