



**THE DATASHEET OF
LMH0071SQE/NOPB**



3 Gbps, HD, SD, DVB-ASI SDI Deserializer with Loophrough and LVDS Interface

 Check for Samples: [LMH0041](#), [LMH0051](#), [LMH0071](#), [LMH0341](#)

FEATURES

- 5-Bit LVDS Interface
- No External VCO or Clock Required
- Reclocked Serial Loophrough With Cable Driver
- Powerdown Mode
- 3.3V SMBus Configuration Interface
- Small 48-Pin WQFN Package
- Industrial Temperature range: -40°C to +85°C

APPLICATIONS

- SDI Interfaces for:
 - Video Cameras
 - DVRs
 - Video Switchers
 - Video Editing Systems

KEY SPECIFICATIONS

- Output compliant with SMPTE 259M-C, SMPTE 292M, SMPTE 424M and DVB-ASI (See [Table 1](#))
- Typical power dissipation: 590 mW (loophrough disabled, 3G datarate)
- 0.6 UI Minimum Input Jitter Tolerance

DESCRIPTION

The LMH0341/0041/0071/0051 SDI Deserializers are part of TI's family of FPGA-Attach SER/DES products supporting 5-bit LVDS interfaces with FPGAs. When paired with a host FPGA the LMH0341 automatically detects the incoming data rate and decodes the raw 5-bit data words compliant to any of the following standards: DVB-ASI, SMPTE 259M, SMPTE 292M, or SMPTE 424M. See [Table 1](#) for details on which Standards are supported per device.

The interface between the LMH0341 and the host FPGA consists of a 5-bit wide LVDS bus, an LVDS clock and an SMBus interface. No external VCOs or clocks are required. The LMH0341 CDR detects the frequency from the incoming data stream, generates a clean clock and transmits both clock and data to the host FPGA. The LMH0341, LMH0041 and LMH0071 include a serial reclocked loophole with integrated SMPTE compliant cable driver. Refer to [Table 1](#) for a complete listing of single channel deserializers offered in this family.

The FPGA-Attach SER/DES product family is supported by a suite of IP which allows the design engineer to quickly develop video applications using the SER/DES products. The product is packaged in a physically small 48 pin WQFN package.

General Block Diagram

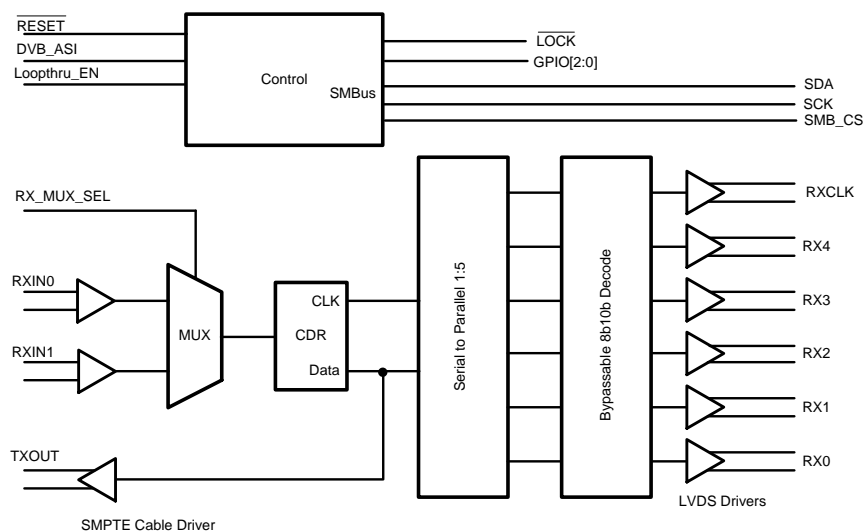

Please be aware that an important notice concerning availability, standard warranty, and use in critical applications of Texas Instruments semiconductor products and disclaimers thereto appears at the end of this data sheet.

TRI-STATE is a registered trademark of National Semiconductor Corporation.
All other trademarks are the property of their respective owners.

Connection Diagrams

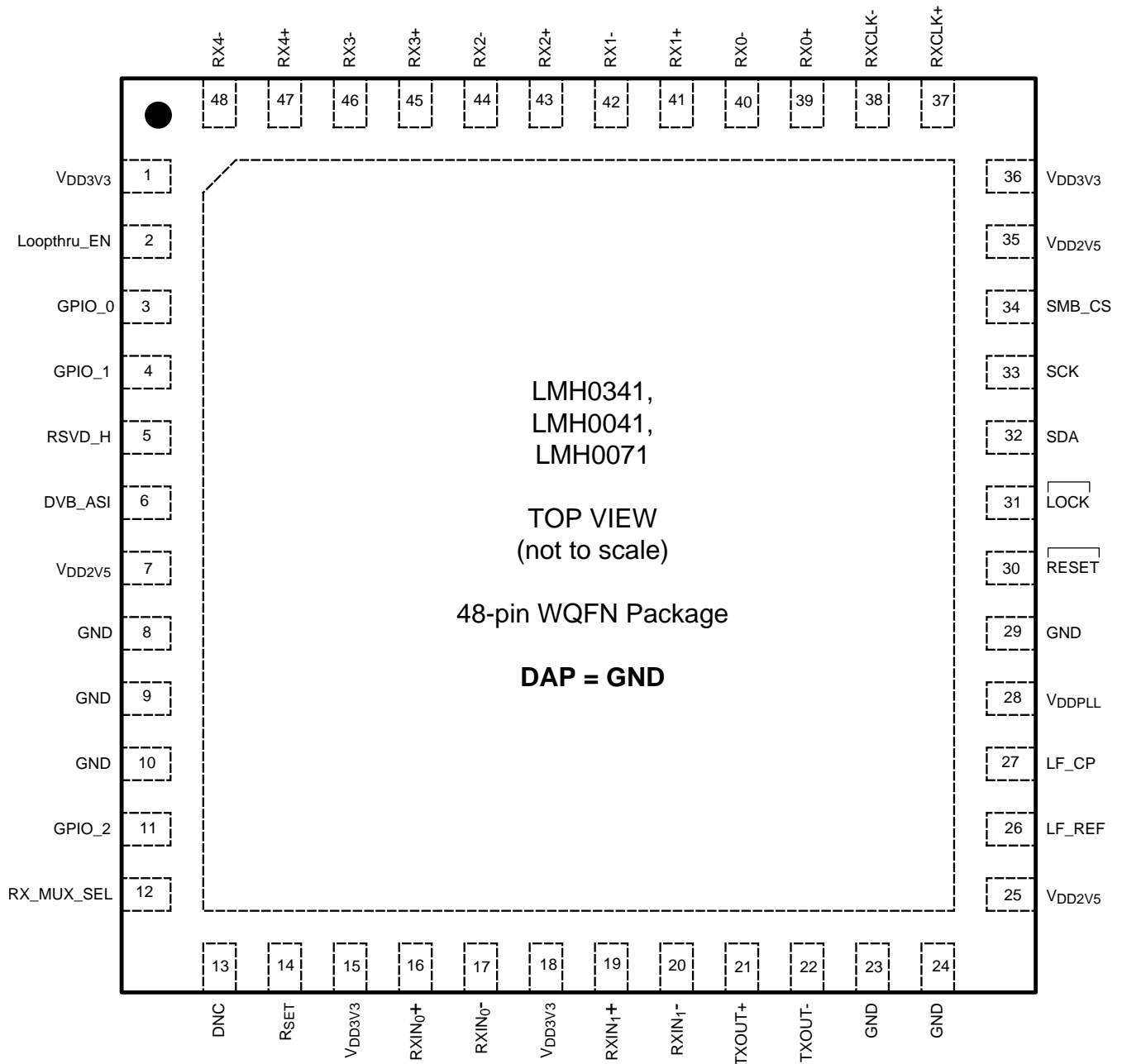

Figure 1. Connection Diagram for LMH0341 / LMH0041 / LMH0071

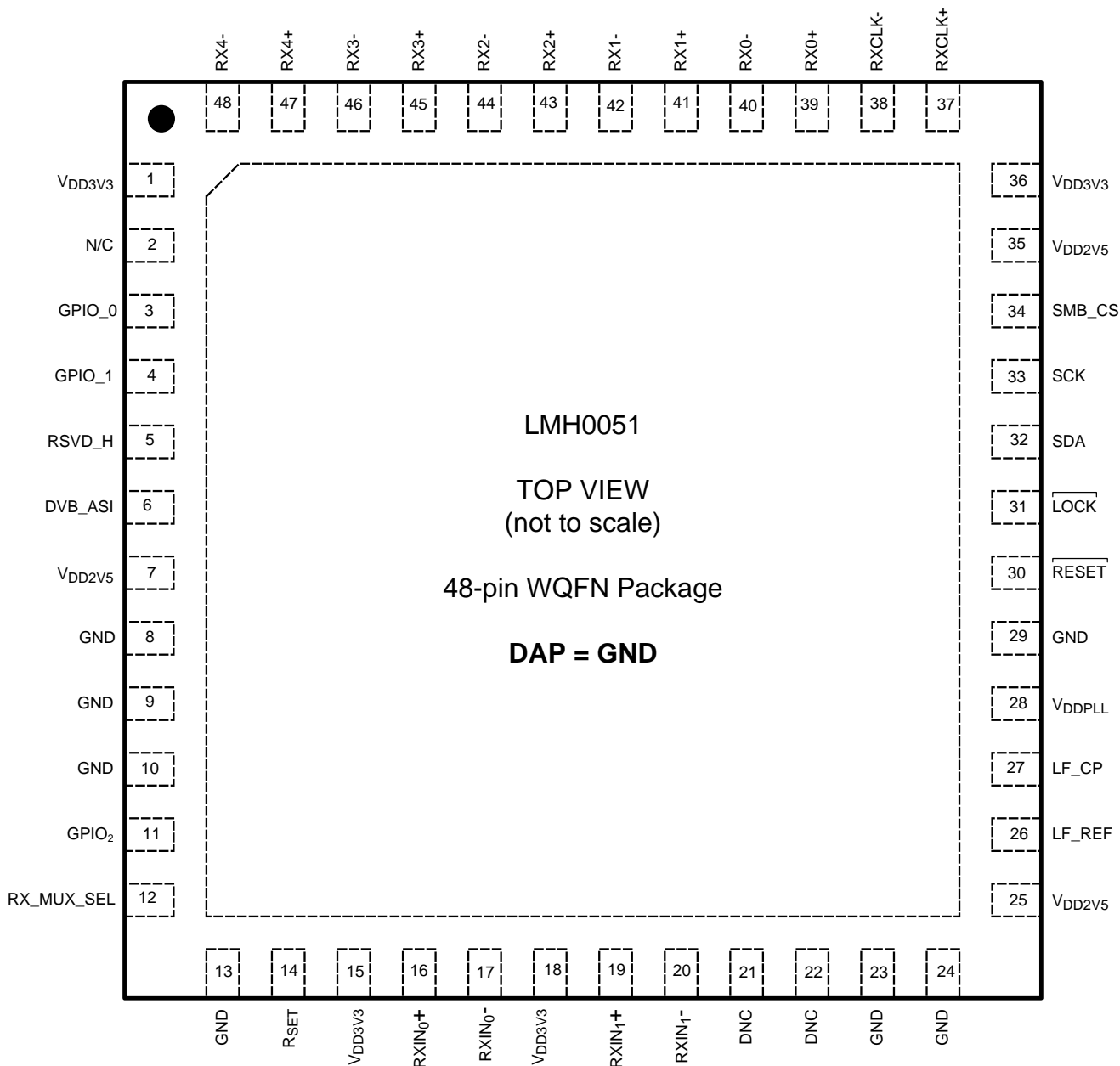

Figure 2. Connection Diagram for LMH0051

PIN DESCRIPTIONS

| Pin Name | Type | Description |
|--|---------------------|--|
| LVDS Input Interface | | |
| RX[4:0]+ RX[4:0]- | Output, LVDS | LVDS Data Output Pins Five channel wide DDR interface. |
| RXCLK+ RXCLK- | Output, LVDS | LVDS Clock Output Pins DDR Interface. |
| Serial Data Inputs | | |
| RXIN ₀ + RXIN ₀ - | Input, Differential | Serial differential input Pins Channel 0 |
| RXIN ₁ + RXIN ₁ - | Input, Differential | Serial differential input Pins Channel 1 |
| Loophrough Serial Output | | |
| TXOUT+ | Output, CML | Serial Digital Interface Output Pin Non-Inverting Output |
| TXOUT- | Output, CML | Serial Digital Interface Output Pin Inverting Output |
| SMBus Interface | | |
| SDA | I/O, LVCMOS | SMBus Data I/O Pin |
| SCK | Input, LVCMOS | SMBus Clock Input Pin |
| SMB_CS | Input, LVCMOS | SMBus Chip Select Input Pin Device is selected when High. |
| Control and Configuration Pins | | |
| $\overline{\text{RESET}}$ | Input, LVCMOS | Reset Input Pin H = normal mode L = device in RESET |
| $\overline{\text{LOCK}}$ | Output, LVCMOS | PLL LOCK Status Output H = unlock condition L = PLL is Locked |
| DVB_ASI | Input, LVCMOS | DVB_ASI Select Input H = DVB_ASI Mode enabled L = Normal Mode enabled |
| Loophtru_EN | Input, LVCMOS | Loophrough enable Input H=Reclocked Loophrough active L=Reclocked Loophrough disabled |
| RX_MUX_SEL | Input, LVCMOS | Input multiplexer select H=RXIN ₁ selected L=RXIN ₀ selected |
| GPIO[2:0] | I/O, LVCMOS | General Purpose Input / Output Software configurable I/O pins. |
| RSVD_H | Input, LVCMOS | Configuration Input – Must tie High Pull High via 5 k Ω resistor to V _{DD3V3} |
| Analog Inputs | | |
| R _{SET} | Input | Serial Loophrough Output Amplitude Control Resistor connected from this pin to ground to set the signal amplitude. Nominally 7.87k Ω for 800mV output (SMPTE). |
| LF_CP | Input | Loop Filter Connection |
| LF_REF | | Loop Filter Reference |
| DNC | | Do Not Connect – Leave Open |
| Power Supply and Ground | | |
| V _{DD3V3} | Power | 3.3V Power Supply connection |
| V _{DDPLL} | Power | 3.3V PLL Power Supply connection |
| V _{DD2V5} | Power | 2.5V Power Supply connection |
| GND | Ground | Ground connection – The DAP (large center pad) is the primary GND connection for the device and must be connected to Ground along with the GND pins. |

Table 1. Feature Table

| Device | SMPTE 424M Support | SMPTE 292M Support | SMPTE 259M Support | DVB-ASI Support | Active Loophrough |
|---------|--------------------|--------------------|--------------------|-----------------|-------------------|
| LMH0341 | x | x | x | x | x |
| LMH0041 | | x | x | x | x |
| LMH0071 | | | x | x | x |
| LMH0051 | | x | x | x | |



These devices have limited built-in ESD protection. The leads should be shorted together or the device placed in conductive foam during storage or handling to prevent electrostatic damage to the MOS gates.

Absolute Maximum Ratings ⁽¹⁾⁽²⁾

| | |
|--|-------------------------------|
| Supply Voltage (V_{DD3V3}) | -0.3V to +4.0V |
| Supply Voltage (V_{DD2V5}) | -0.3V to +3.0V |
| LVCMOS input voltage | -0.3V to ($V_{DD3V3}+0.3V$) |
| LVCMOS output voltage | -0.3V to ($V_{DD3V3}+0.3V$) |
| SMBus I/O Voltage | -0.3V to +3.6V |
| LVDS Input Voltage | 0.3V to 3.6V |
| Junction Temperature | +150°C |
| Storage Temperature | -65° to 150°C |
| Lead Temperature—Soldering 4 seconds | +260°C |
| Thermal Resistance— Junction to Ambient— θ_{JA} | 26°C/W |
| ESD Rating—Human Body Model, 1.5 K Ω , 100 pF | $\geq \pm 8KV$ |

- (1) “Absolute Maximum Ratings” are the ratings beyond which the safety of the device cannot be ensured. It is not implied that the device will operate up to these limits.
 (2) If Military/Aerospace specified devices are required, please contact the TI Sales Office/Distributors for availability and specifications.

Recommended Operating Conditions

| Parameter | Min | Typ | Max | Units |
|---|---------|------|-------|-------------------|
| Supply Voltage ($V_{DD3V3-GND}$) | 3.135 | 3.3 | 3.465 | V |
| Supply Voltage ($V_{DD2V5-GND}$) | 2.375 | 2.5 | 2.625 | V |
| Supply noise amplitude (10 Hz to 50 MHz) | | | 100 | mV _{P-P} |
| Ambient Temperature | -40 | +25 | +85 | °C |
| Case Temperature | | | 102 | °C |
| Input Data Rate | LMH0341 | 270 | 2970 | Mbps |
| | LMH0041 | 270 | 1485 | Mbps |
| | LMH0071 | 270 | 270 | Mbps |
| | LMH0051 | 270 | 1485 | Mbps |
| LVDS PCB board trace length (mismatch <2%) | | | 25 | cm |
| R_{STERM} — SMBus termination resistor value | | 1000 | | Ω |
| Loophrough Output Driver Pullup Resistor Termination Voltage ⁽¹⁾ | | 2.5 | 2.625 | V |

- (1) Maximum termination voltage should be identical to the device supply voltage.

Electrical Characteristics

Over supply and Operating Temperature ranges unless otherwise specified. ⁽¹⁾

| Symbol | Parameter | Condition | Min | Typ | Max | Units |
|--------------------|---|--|------------|-----|-----|-------|
| I _{DD2.5} | 2.5V supply current for LMH0341, LMH041, LMH0071 | 2.97 Gbps LT off | | 67 | 77 | mA |
| | | 1.485 Gbps LT off ⁽²⁾ | | 52 | 59 | mA |
| | | 270 Mbps LT off ⁽²⁾ | | 40 | 46 | mA |
| | | 2.97 Gbps LT on | | 99 | 108 | mA |
| | | 1.486 Gbps LT on ⁽²⁾ | | 84 | 92 | mA |
| | | 270 Mbps LT on ⁽²⁾ | | 65 | 71 | mA |
| | | 2.5V supply current for LMH0051 | 1.485 Gbps | | 52 | 59 |
| 270 Mbps | | | 40 | 46 | mA | |
| I _{DD3.3} | 3.3V supply current for LMH0341, LMH0041, LMH0071 | LT off ⁽²⁾ | | 106 | 120 | mA |
| | | LT on ⁽²⁾ | | 112 | 127 | mA |
| | 3.3V supply current for LMH0051 | | 106 | 119 | mA | |
| P _D | Power Consumption | 2.97 Gbps, loophthrough enabled | | 617 | 710 | mW |
| | | 1.485 Gbps, loophthrough enabled ⁽²⁾ | | 580 | 670 | mW |
| | | 270 Mbps, Loophthrough enabled ⁽²⁾ | | 532 | 620 | mW |
| | | 2.97 Gbps, Loophthrough Disabled ⁽²⁾ | | 517 | 610 | mW |
| | | 1.485 Gbps, Loophthrough Disabled ⁽²⁾ | | 480 | 560 | mW |
| | | 270 Mbps, Loophthrough Disabled ⁽²⁾ | | 450 | 530 | mW |

(1) Typical Parameters measured at V_{DD}=3.3V, T_A=25°C. They are for reference purposes and are not production tested.

(2) Specification ensured by Characterization for LMH0341, other variants production tested

Control Pin Electrical Characteristics

Over supply and Operating Temperature ranges unless otherwise specified. Applies to DVB_ASI, $\overline{\text{RESET}}$ and $\overline{\text{LOCK}}$, GPIO Pins, RX_MUX_SEL, Loopthru_EN⁽¹⁾

| Symbol | Parameter | Condition | Min | Typ | Max | Units |
|-----------------|------------------------------|--|------|------|-------------------------|-------|
| V _{IH} | High Level Input Voltage | | 2.0 | | V _{DD3V3} +0.3 | V |
| V _{IL} | Low Level Input Voltage | | -0.3 | | 0.8 | V |
| V _{OH} | High Level Output Voltage | I _{OH} = -0.4 mA | 2.7 | 3.25 | | V |
| | | I _{OH} = -2 mA | 2.7 | 3.2 | | V |
| V _{OL} | Low Level Output Voltage | I _{OL} = 2 mA | | 0.1 | 0.3 | V |
| V _{CL} | Input Clamp Voltage | I _{CL} = -18 mA | | 0.9 | -1.5 | V |
| I _{IN} | Input Current | V _{IN} = 0.4V, 2.5V or V _{DD} Pullup and pulldown resistors not enabled. | -40 | | 40 | μA |
| I _{OS} | Output Short Circuit Current | V _{OUT} = 0V | | -44 | | mA |

(1) Typical Parameters measured at V_{DD}=3.3V, T_A=25°C. They are for reference purposes and are not production tested.

SDI Input Electrical Characteristics

Over supply and Operating Temperature ranges unless otherwise specified. ⁽¹⁾

| Symbol | Parameter | Condition | Min | Typ | Max | Units |
|--------------------|---|--|------|-----------------------------------|------|----------------------|
| V _{ID} | Input Differential Voltage | DC Coupled, V _{CM} = 0.05V to V _{DD} -0.05V ⁽²⁾ | 230 | | 2200 | mV |
| I _{IN} | Input Current | 0V < V _{IN} < 2.4V | -350 | | 50 | μA |
| R _{IT} | Input Termination | | 84 | 100 | 116 | Ω |
| TOL _{JIT} | Input Jitter Tolerance | Frequency < f ₂ (From SMPTE RP 184) | | 6 | | UI |
| | | Frequency < f ₃ | | 0.6 | | UI |
| λ _{BW} | Jitter Transfer Function 3 dB loop bandwidth | See Figure 9 | | 0.13% | | Fraction of Datarate |
| δ | Jitter Peaking | See Figure 9 | | 0.05 | | dB |
| RL | Input Return Loss | Measured on 'ALP' evaluation board ⁽²⁾ | | >25dB to 1.5GHz >12dB to 3 GHz | | dB |

(1) Typical Parameters measured at V_{DD}=3.3V, T_A=25°C. They are for reference purposes and are not production tested.

(2) Specification ensured by characterization

LVDS Output Electrical Characteristics

Over supply and Operating Temperature ranges unless otherwise specified. ⁽¹⁾

| Symbol | Parameter | Condition | Min | Typ | Max | Units |
|------------------|---|--|-------|------|-------|-------|
| V _{OD} | Differential Output Voltage | R _L = 100Ω | 230 | | 310 | mV |
| ΔV _{OD} | Change in V _{OD} between complementary output states | | | | 35 | mV |
| V _{OS} | Offset Voltage | | 1.125 | 1.25 | 1.375 | V |
| ΔV _{OS} | Change in V _{OS} between complementary output states | | | | 35 | mV |
| I _{OS} | Output Short Circuit Current | V _{OUT} = 0V, R _L = 100Ω | -50 | | | mA |

(1) Typical Parameters measured at V_{DD}=3.3V, T_A=25°C. They are for reference purposes and are not production tested.

LVDS Switching Characteristics

Over supply and Operating Temperature ranges unless otherwise specified. ⁽¹⁾

| Symbol | Parameter | Condition | Min | Typ | Max | Units |
|------------|--|--|------|------|-----|-------|
| t_{ROTR} | LVDS Low to High Transition time | See Figure 3 LVDS Switching times | | 300 | | ps |
| t_{ROTF} | LVDS High to Low Transition time | | | 300 | | ps |
| t_{ROCP} | Receiver output clock period | RxCLKOUT is DDR. If divide by 4 is enabled, the output clock period will be doubled | | 2T | | ns |
| t_{RODC} | RxCLKOUT Duty Cycle | | 45 | 50 | 55 | % |
| t_{ROCH} | RxCLKOUT high time | See Receiver timing specifications | 1.51 | | | ns |
| t_{ROCL} | RxCLKOUT low time | | 1.51 | | | ns |
| t_{RBIT} | Receiver output bit width | | | T | | ns |
| t_{DVBC} | RX data transition to RXCLK transition | See Receiver timing specifications ⁽²⁾ | 650 | | | ps |
| t_{DVAC} | RXCLK transition to RX data transition | | 650 | | | ps |
| t_{ROJR} | Receiver output Random Jitter | Receiver output intrinsic random jitter. Bit error rate $\leq 10^{-15}$. Alternating 10 pattern. RMS ⁽³⁾ | | 2.5 | | ps |
| t_{ROJT} | Peak-to-Peak Receiver Output Jitter | ⁽³⁾ | | 70 | 125 | ps |
| t_{RD} | Receiver Propagation Delay | See Figure 5 Receiver (LVDS Interface) Propagation Delay | | 12 T | | |
| t_{RLA} | Receiver Link Acquisition Time | From device reset or change in input data rate to locked condition | | | 24 | ms |
| t_{LVSK} | LVDS Output Skew | LVDS Differential Output Skew between + and - pins | | 20 | | ps |

(1) Typical Parameters measured at $V_{DD}=3.3V$, $T_A=25^\circ C$. They are for reference purposes and are not production tested.

(2) Specification Characterized at 2.97 Gbps, 1.485 Gbps and 270 Mbps, production tested at 270 Mbps only

(3) Specification ensured by characterization

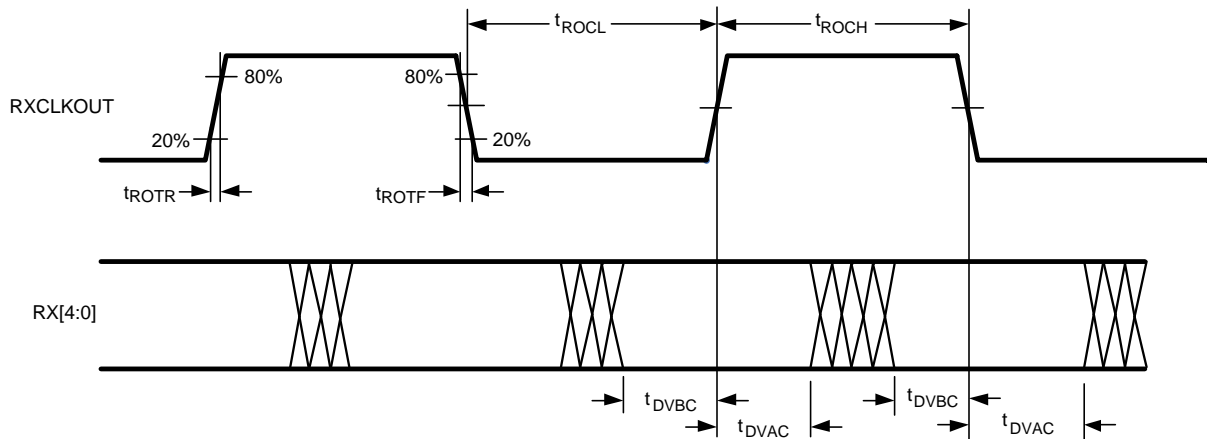

Figure 3. LVDS Switching Times

SMBus Input Electrical Characteristics

Over supply and Operating Temperature ranges unless otherwise specified. ⁽¹⁾

| Symbol | Parameter | Condition | Min | Typ | Max | Units |
|---------------------|------------------------------------|-----------------------------------|-------|-----|------------------|-------|
| V _{SIL} | Data, Clock Input Low Voltage | | | | 0.8 | V |
| V _{SIH} | Data, Clock Input High Voltage | | 2.1 | | V _{SDD} | V |
| V _{SDD} | Nominal Bus Voltage | | 2.375 | | 3.465 | V |
| V _{OL} | Output Low voltage | I _{OL} =2mA | | | 0.3 | V |
| I _{SLEAKB} | Input Leakage per bus segment | See ⁽²⁾ | -200 | | 200 | μA |
| I _{SLEAKP} | Input Leakage per pin | SCK and SDA pins | -10 | | 10 | μA |
| C _{SI} | Capacitance for SMBdata and SMBclk | See ⁽²⁾ ⁽³⁾ | | | 10 | pF |

(1) Typical Parameters measured at V_{DD}=3.3V, T_A=25°C. They are for reference purposes and are not production tested.

(2) Recommended value—Parameter is not tested.

(3) Recommended maximum capacitance load per bus segment is 400 pF.

SMBus Switching Characteristics

Over supply and Operating Temperature ranges unless otherwise specified. ⁽¹⁾

| Symbol | Parameter | Condition | Min | Typ | Max | Units |
|---------------------|---|-------------------------------|-----|-----|-----|-------|
| f _{SMB} | Bus Operating Frequency | | 10 | | 100 | kHz |
| t _{BUF} | Bus free time between stop and start condition | | 4.7 | | | μs |
| t _{SU:CS} | Minimum time between SMB_CS being active and Start condition | ⁽²⁾ | 30 | | | ns |
| t _{H:CS} | Minimum time between stop condition and releasing SMB_CS | ⁽²⁾ | 100 | | | ns |
| t _{HD:STA} | Hold time after (repeated) start condition. After this period, the first clock is generated | At I _{SPULLUP} = MAX | 4.0 | | | μs |
| t _{SU:STA} | Repeated Start condition setup time | | 4.7 | | | μs |
| t _{SU:STO} | Stop Condition setup time | | 4.0 | | | μs |
| t _{HD:DAT} | Data hold time | | 300 | | | ns |
| t _{SU:DAT} | Data setup time | | 250 | | | ns |
| t _{LOW} | Clock Low Period | | 4.7 | | | μs |
| t _{HIGH} | Clock high time | | 4.0 | | 50 | μs |
| t _{POR} | Time in which a device must be operational after power on | | | | 500 | ms |

(1) Typical Parameters measured at V_{DD}=3.3V, T_A=25°C. They are for reference purposes and are not production tested.

(2) Specification ensured by characterization

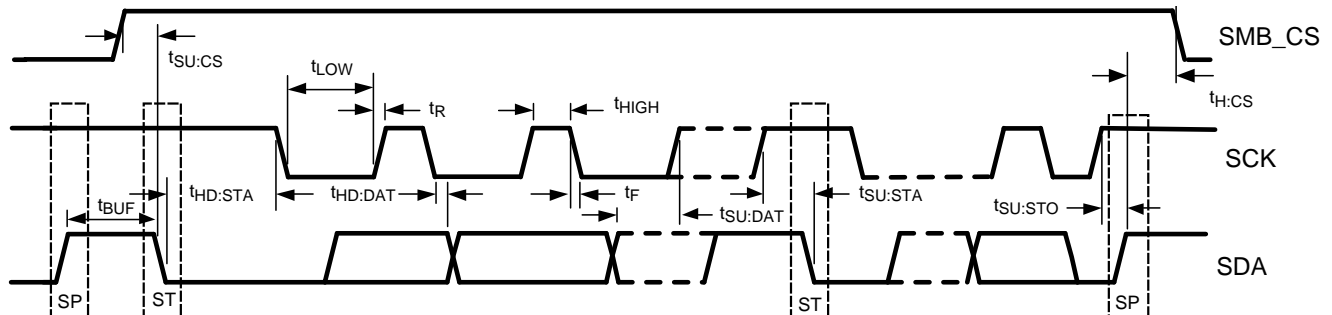

Figure 4. SMBus Timing Parameters

SDI Output Switching Characteristics (LMH0341 / LMH0041 / LMH0071)

Over supply and Operating Temperature ranges unless otherwise specified. ⁽¹⁾

| Symbol | Parameter | Condition | Min | Typ | Max | Units |
|--------------|--|---|-----|-----------|------|-------|
| | SDI Output Datarate | | 270 | | 2970 | MHz |
| t_r | SDI Output Rise Time | DR=2.97 Gbps ⁽²⁾ | | | 135 | ps |
| | | DR=1.485 Gbps ⁽²⁾ | | | 145 | |
| | | DR=270 Mbps ⁽²⁾ | 400 | | 1000 | |
| t_f | SDI Output Fall Time | DR=2.97 Gbps ⁽²⁾ | | | 135 | ps |
| | | DR=1.485 Gbps ⁽²⁾ | | | 145 | ps |
| | | DR = 270 Mbps ⁽²⁾ | 400 | | 1000 | ps |
| Δt_t | Mismatch between Rise and Fall times | 2.97 Gbps ⁽²⁾ | | | 25 | ps |
| | | 1.485 Gbps ⁽²⁾ | | | 30 | ps |
| | | 270 Mbps ⁽²⁾ | | | 100 | ps |
| t_{SD} | Propagation Delay Latency | | | t_{CIP} | | ns |
| t_J | Peak to Peak Output Jitter | 2.97 Gbps ⁽²⁾ (3) | | 25 | 40 | |
| | | 1.485 Gbps ⁽²⁾ (3) | | 35 | 50 | |
| | | 270 Mbps ⁽²⁾ (3) | | 65 | 110 | |
| V_{OD} | SDI Output Voltage(Loopthrough Output) | Into 75 Ω Load | 720 | 800 | 880 | mV |
| RL | Output Return Loss | Measured 5 MHz to 1483 MHz ⁽²⁾ | | 15 | | dB |
| t_{OS} | Output Overshoot | ⁽²⁾ | | | 5 | % |

- (1) Typical Parameters measured at $V_{DD}=3.3V$, $T_A=25^\circ C$. They are for reference purposes and are not production tested.
- (2) Specification ensured by characterization
- (3) Measured in accordance with SMPTE RP184.

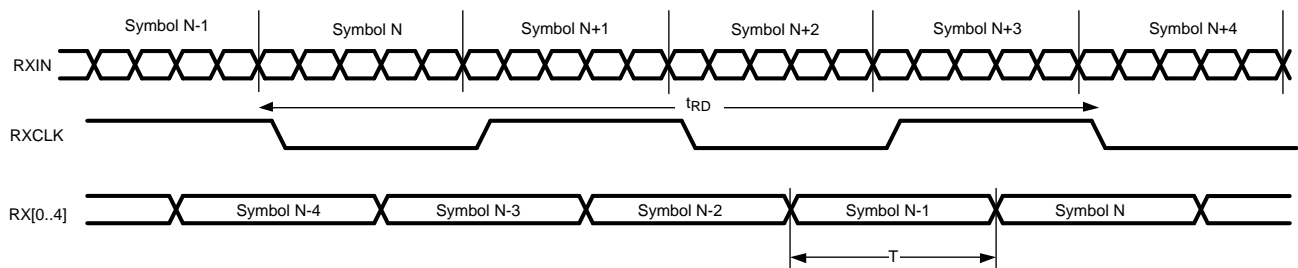

Figure 5. Receiver (LVDS Interface) Propagation Delay

FUNCTIONAL DESCRIPTION

DEVICE OPERATION

The DES is used in digital video signal origination equipment. It is intended to be operated in conjunction with an FPGA host which processes data received by the SER, and converts the five bit output data to an appropriate parallel video format — usually 10 or 20 bits wide. In most applications, the input data to the DES will be data compliant with DVB ASI, SMPTE 259M-C, SMPTE 292M or SMPTE 424M, and the decoding will be done by the IP provided by TI or similar IP to result in a decoded output. TI offers IP in source code format to perform the appropriate decoding of the data, as well as evaluation platforms to assist in the development of target applications. For more information please contact your local TI Sales Office/Distributor

POWER SUPPLIES

The DES has several power supply pins, at 2.5V as well as 3.3V. It is important that these pins all be connected, and properly bypassed. Bypassing should consist of parallel 4.7 μ F and 0.1 μ F capacitors as a minimum, with a 0.1 μ F capacitor on each power pin. The device has a large contact in the center of the bottom of the package. This contact must be connected to the system GND as it is the major ground connection for the device. A 22 μ F capacitor is required on the V_{DDPLL} pin which is connected to the 3.3V rail

Discrete bypassing is ineffective above 30 MHz to 50 MHz in power plane-based distribution systems. Above this frequency range, the intrinsic capacitance of the power-ground system can be used to provide additional RF bypassing. To make the best use of this, make certain that there are PCB layers dedicated to the Power supplies and to GND, and that they are placed next to each other to provide a distributed capacitance between power and GND.

The DES will work best when powered from linear regulators. The output of linear regulators is generally cleaner with less noise than switching regulators. Output filtering and power system frequency compensation are generally simpler and more effective with linear regulators. Low dropout linear regulators are available which can usually operate from lower input voltages such as logic power supplies, thereby reducing regulator power dissipation. Cascading of low dropout regulators should not be done since this places the entire supply current load of both load systems on the first regulator in the cascade and increases its loading and thermal output.

POWER UP

The 3.3V power supply should be brought up before the 2.5V supply. The timing of the supply sequencing is not important. The device has a power on reset sequence which takes place once both power supplies are brought up. This sequence will reset all register contents to their default values, and will place the PLLs into link acquisition mode, attempting to lock on the RXIN₀ input.

RESET

There are three ways in which the device may be reset. There is an automatic reset which happens on power-up; there is a reset pin, which when brought low will reset the device, with normal operation resuming when the pin is driven high again. The third way to reset the device is a soft reset, implemented via a write to the reset register. This reset will put all of the register values back to their default values, except it will not affect the address register value if the SMBus default address has been changed.

LVDS OUTPUTS

The DES has LVDS outputs, compatible with ANSI/TIA/EIA-644. LVDS outputs expect to drive a 100 Ω transmission line which is properly terminated at the host FPGA inputs. It is recommended that the PCB trace between the FPGA and the receiver be less than 25 cm. Longer PCB traces may introduce signal degradation as well as channel skew which could cause serialization errors.

The LVDS outputs on the DES have a programmable output swing. The default condition is for the smaller size swing, in order to save power. If a larger amplitude output swing is desired, this can be effected through the use of register 0x27h

LVDS OUTPUT TIMING

The DES output timing, in its default condition, is described in [LVDS Switching Characteristics](#). The user has the ability to adjust the LVDS output timing to make it easier to latch into the host FPGA if desired. This is done via register 0x28h where both the clock to data timing may be adjusted, as well as changing the RXCLK from being a DDR clock to a clock at the rate of DDR/2

LOOP FILTER

The DES has an internal PLL which is used to recover the embedded clock from the input data. The loop filter for this PLL has external components, and for optimum results in Serial Digital Interface applications, a capacitor and a resistor in series should be connected between pins 26 and 27 as shown in the typical interface circuit.

DVB-ASI MODE

DVB-ASI mode is enabled when the DVB-ASI pin is brought to a high state. When the DVB-ASI mode is enabled, an internal framer and 8b10b decoder is engaged such that the data appearing on RX0-RX3 will represent a nibble of the decoded 8b10b data. RX4 is an Idle character detect and can be used as an enable to allow the receiver to not write data into an external FIFO. RX4 is high if the data being presented on RX0-RX3 represents the idle character. The Least Significant Nibble of data is presented on the rising edge of RXCLK, and the most significant on the falling edge of RXCLK.

The internal 8b10b decoder needs to receive up to 110 consecutive K28.5 characters to properly initialize and frame the data so that the decoded 8b10b data presented at the output of the device is correct.

SDI INPUT INTERFACING

The device has two inputs, one of which is selected via a multiplexer with the RX_MUX_SEL pin. Whichever input is selected will be routed to the clock recovery portion of the deserializer, and once it is reclocked, the signal will be fed to the loophrough outputs. Most SDI interfaces require an equalizer to meet performance requirements. For HD-SDI and SD-SDI applications, the LMH0044 is an ideal equalizer to use for this. The LMH0044 is packaged in a small compact package and the outputs can be connected directly to the RXIN inputs of the LMH0041. The LMH0344 is pin compatible with the LMH0044 and will support 3 Gbps data, making it an ideal choice to accompany the LMH0341.

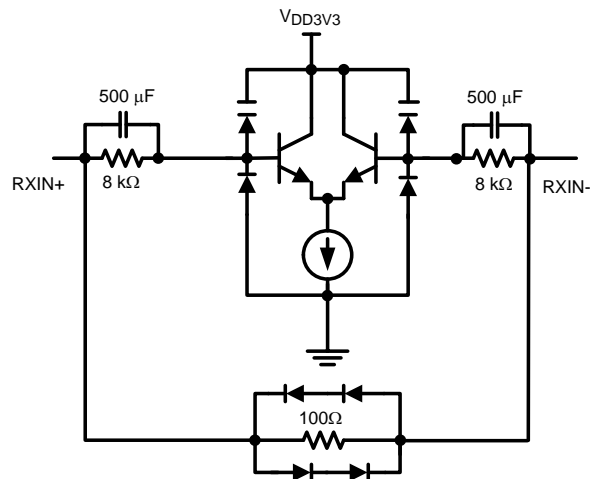

Figure 6. Simplified SDI Input Circuit

SWITCHING SDI INPUTS

When the input to the DES is switched from one source to another, either via the internal 2:1 multiplexer on the inputs, or via an external crosspoint switch, there are a variety of behaviors possible. If the input switch is between two signals operating at the same data rate, then in most cases, the DES will not lose lock. There will be a small number of words with corrupted data as the PLL slews its phase to match the new input signal. Under some circumstances (dependent on phase difference between the inputs, temperature, etc) it is possible that the

PLL will lose lock, and then reacquire lock. This condition can be seen by monitoring the $\overline{\text{LOCK}}$ pin where a high going pulse will indicate a loss of lock condition. If a loss of lock happens, it will be for a time period of approximately 5ms before lock is reattained. In the event that the switch on the input is between signals at different datarates — for example from a 270 Mbps signal to a 1.485 Gbps input, then the lock procedure is much more complex, and the lock time will be significantly longer. In either case, the IP that is processing the received signal will need to reestablish the proper framing of the words.

SDI OUTPUT INTERFACING

The serial loophrough outputs provide low-skew complementary or differential signals. The output buffer is a current mode design, and as such has a high impedance output. To drive a 75Ω transmission line, a 75Ω resistor from each of the output pins to V_{DD2V5} should be connected. This resistor has two functions—it converts the current output to a voltage, which is used to drive the cable, and it acts as the back termination resistor for the transmission line. The output driver automatically adjusts its slew rate depending on the input datarate so that it will be in compliance with SMPTE 259M, SMPTE292M or SMPTE 424M as appropriate. In addition to output amplitude and rise/fall time specifications, the SMPTE specs require that SDI outputs meet an Output Return Loss (ORL) specification. There are parasitic capacitances that will be present both at the output pin of the device and on the application printed circuit board. To optimize the return loss, these must be compensated for, usually with a series network comprising a parallel inductor and resistor. The actual values for these components will vary from application to application, but the typical interface circuit shows values that would be a good starting point.

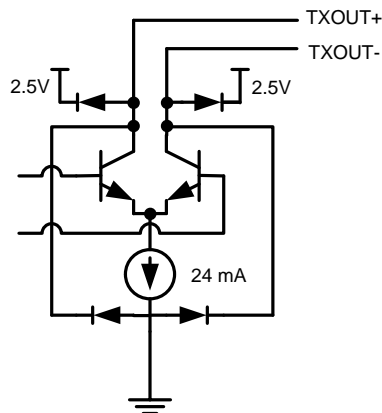

Figure 7. Simplified SDI Output Circuit

JITTER MANAGEMENT

SMPTE 424M (the 3 Gbps standard) relaxed the requirements of SDI transmitters from $0.2UI$ to $0.3UI$, which means that the challenge of receiving these signals error free is very difficult. The parameter of importance to determine if the DES will be able to receive the signal error free is the Jitter Tolerance. Figure 10 shows the LMH0341 Jitter tolerance curve with a 2.97 Gbps input — any signal which has less jitter than what is on the upper curve of Figure 10 will be able to be received by the DES. The lower line in the curve shows the SMPTE requirement for any receiver. There is a slight dip in the level at frequencies above about 10MHz which is an artifact of the test equipment that was used to capture the data. Once the signal is received, the next concern as far as jitter goes is how much of the jitter that was on the input signal will be passed through to the RXCLK output. This is answered by the Jitter transfer characteristics. The Jitter transfer function is the ratio of the input jitter to the output jitter, measured as a function of frequency. The specification tables show two of the parameters related to this curve — δ is the jitter peaking and indicates what the maximum gain of the jitter is. Ideally δ is 0, but a lower number is better. If several devices are used in a system, and the frequency at which δ is maximum is the same for all of them, then the gains will multiply, and there is a risk that there will be excessive jitter accumulating at that frequency. The LMH0341 has very low Jitter peaking, so this should not be a concern. The other parameter of interest is λ which is the jitter transfer bandwidth. Jitter on the input at the

frequency λ is attenuated by 3dB, and any jitter at frequencies greater than λ is attenuated by more than this. From a design standpoint, it means that you primarily only need to worry about the jitter at frequencies below λ . The LMH0341 adjusts its loop bandwidth dependent on datarate, so for the lower datarates, it has a lower loop bandwidth. Figure 10 shows the jitter transfer curve of an LMH0341 with a 2.97 Gbps signal input, 0.5UI of input jitter, and nominal power supplies and temperature.

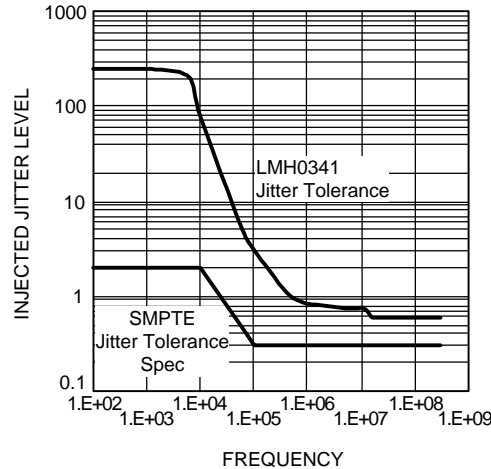

Figure 8. Jitter Tolerance Curve

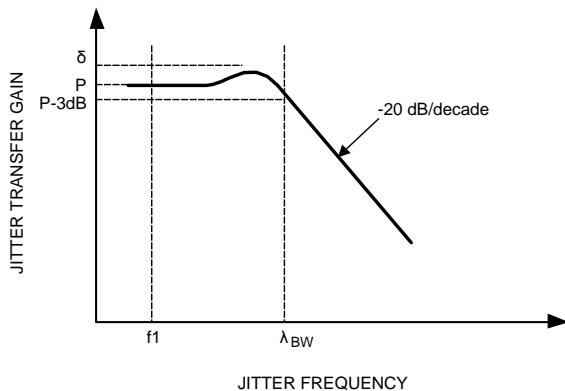

Figure 9. Jitter Transfer Curve Parameters

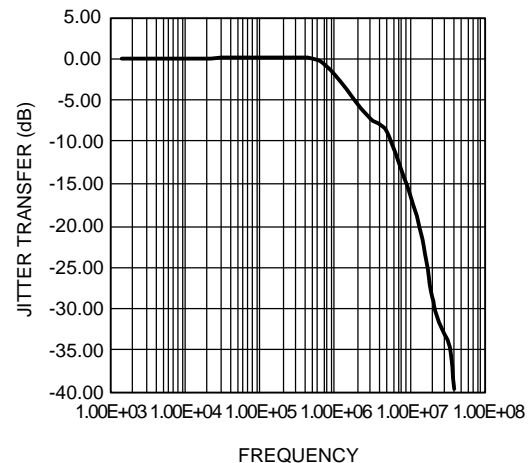

Figure 10. Jitter Transfer Curve

SMBus INTERFACE

The configuration bus conforms to the System Management Bus (SMBus) 2.0 specification. SMBus 2.0 includes multiple options. The optional ARP (Address Resolution Protocol) feature is not supported. The I/O rail is 3.3V only and is not 5V tolerant. The use of the SMB_CS signal is recommended for applications with multi-drop applications (multiple devices to a host).

The System Management Bus (SMBus) is a two wire interface designed for the communication between various system component chips. By accessing the control functions of the circuit via the SMBus, pin count is kept to a minimum while allowing a maximum amount of versatility. The SMBus has three pins to control it, there is an SMBus CS pin which enables the SMBus interface for the device, a Clock and a Data line. In applications where there might be several devices, the SDA and SCK pins can be bussed together and the individual devices to be communicated with may be selected via the CS pin. The SCL and SDA are both open drain and are pulled high by external pullup resistors. The DES has several internal configuration registers which may be accessed via the SMBus. These registers are listed in Table 2.

Transfer Of Data To The Device Via The SMBus

During normal operation the data on SDA must be stable during the time when SCK is high.

START / STOP / IDLE conditions—

There are three unique states for the SMBus:

START A HIGH to LOW transition on SDA while SCK is high indicates a message START condition,

STOP A LOW to HIGH transition on SDA while SCK is high indicates a message STOP condition.

IDLE If SCK and SDA are both high for a time exceeding t_{BUF} from the last detected STOP condition or if they are high for a total exceeding the maximum specification for t_{HIGH} then the bus will transfer to the IDLE state.

SMBus Transactions

A transaction begins with the host placing the DES SMBus into the START condition, then a byte (8 bits) is transferred, MSB first, followed by a ninth ACK bit. ACK bits are '0' to signify an ACK, or '1' to signify NACK, after this the host holds the SCL line low, and waits for the receiver to raise the SDA line as an ACKnowledge that the byte has been received.

WRITING TO REGISTERS VIA THE SMBus INTERFACE

To write a data value to a register in the DES, the host writes three bytes, the first byte is the device address—the device address is a 7 bit value, and if writing to the DES the last bit (LSB) is set to '0' to signify that the operation is a write. The second byte written is the register address, and the third byte written is the data to be written into the addressed register. If additional data writes are performed, the register address is automatically incremented. At the end of the write cycle the host places the bus in the STOP state.

READING FROM REGISTERS VIA THE SMBus INTERFACE

To read the data value from a register, first the host writes the device address with the LSB set to a '0' denoting a write, then the register address is written to the device. The host then reasserts the START condition, and writes the device address once again, but this time with the LSB set to a '1' denoting a read, and following this the DES will drive the SDA line with the data from the addressed register. The host indicates that it has finished reading the data by asserting a '1' for the ACK bit. After reading the last byte, the host will assert a '0' for NACK to indicate to the DES that it does not require any more data.

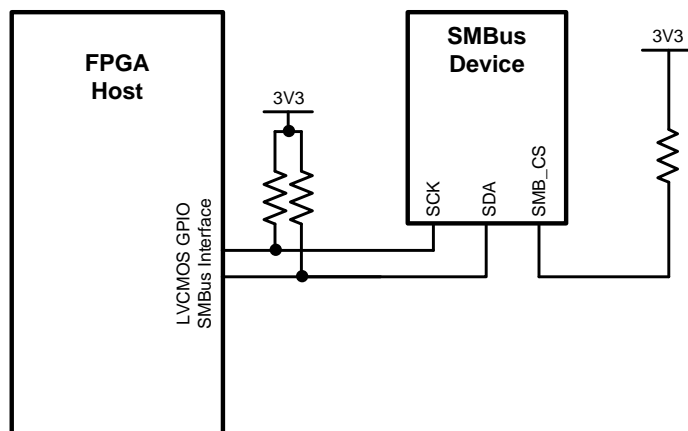

Figure 11. SMBus Configuration 1 — Host to single device

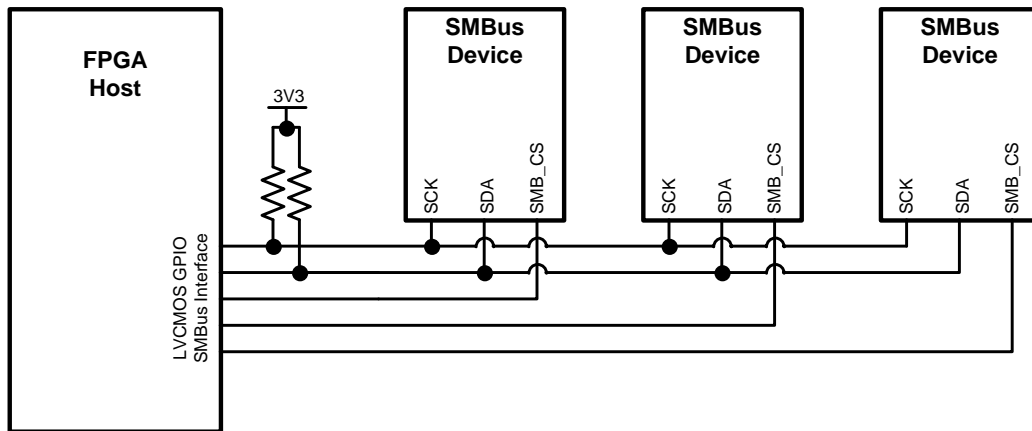

Figure 12. SMBus Configuration 2 — Host to multiple devices with SMB_CS signals

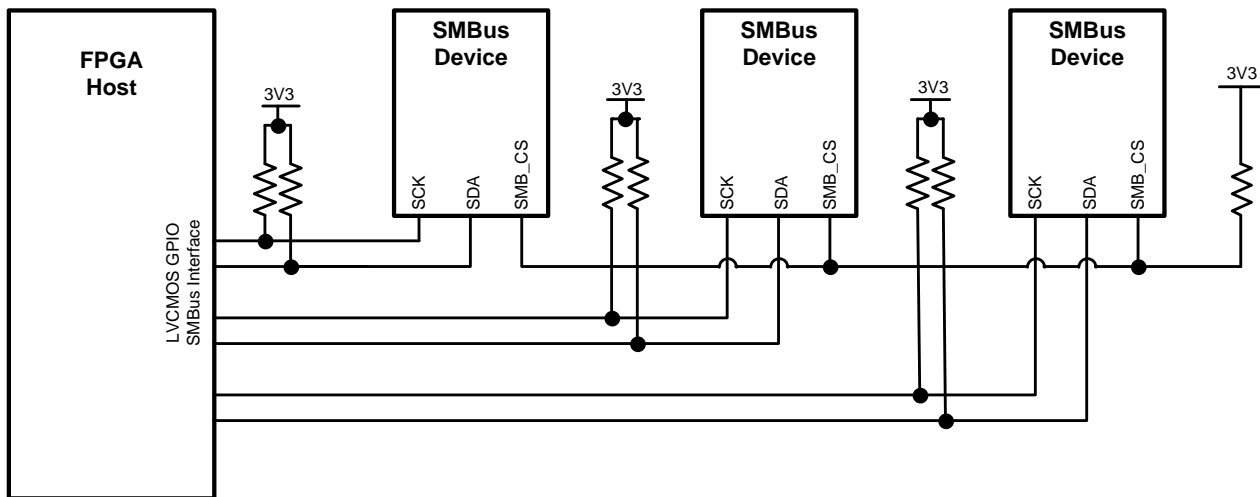

Figure 13. SMBus Configuration 3 — Host to multiple devices with multiple SMBus Interfaces

GENERAL PURPOSE I/O PINS (GPIO)

The DES has three pins which can be configured to provide direct access to certain register values via a dedicated pin. For example if a particular application required fast action to the condition of the deserializer losing its input signal, the PCLK detect status bit could be routed directly to an external pin where it might generate an interrupt for the host processor. GPIO pins can be configured to be in TRI-STATE[®] (High Impedance) mode, the buffers can be disabled, and when used as inputs can be configured with a pullup resistor, a pulldown resistor or no input pin biasing at all.

Each of the GPIO pins has a register to control it. For each of these registers, the upper 4 bits are used to define what function is desired of the GPIO pin with options being slightly different for each of the three GPIO pins. The pins can be used to monitor the status of various internal states of the LMH0040 device, to serve as an input from some external stimulus, and for output to control some external function.

GPIO₀ Functions

- Allow for the output of a signal programmed by the SMBus
- Allow the monitoring of an external signal via the SMBus
- Monitor the status of the signal on input 0

GPIO₁ Functions

- Monitor Power On Reset

- Allow for the output of a signal programmed by the SMBus
- Allow the monitoring of an external signal via the SMBus Monitor the status of the signal on input 1
- Monitor Lock condition of the input clock recovery PLL

GPIO₂ Functions

- Allow for the output of a signal programmed by the SMBus
- Allow the monitoring of an external signal via the SMBus
- Provides a constant clock signal
- LVDS TX Clock at 1/20 full rate
- CDR Clock at 1/20 full rate

Bits 2 and 3 are used to determine the status of the internal pullup/pulldown resistors on the device—they are loaded according to the following truth table:

- 00: pullup and pulldown disabled
- 01: pulldown enabled
- 10: pullup enabled
- 11: reserved

Bit 1 is used to enable or disable the input buffer. If the GPIO pin is to be used as an output pin, then this bit must be set to a '0' disabling the output.

The LSB is used to switch the output between normal output state and high impedance mode. If the GPIO is to be used as an input pin, this bit must be set to '0' placing the output in high Z mode.

As an example, if you wanted to use the GPIO₀ pin to monitor the status of the input signal on input 0, you would load register 02h with the value 0010 0001b

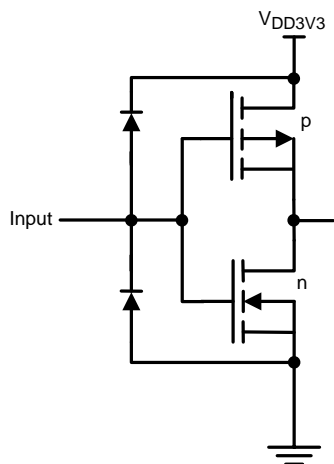

Figure 14. Simplified LVC MOS Input Circuit

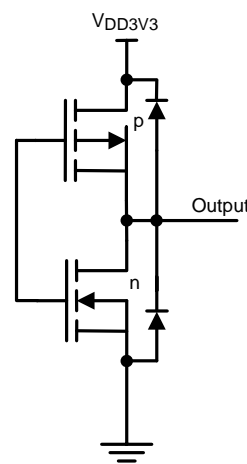

Figure 15. Simplified LVC MOS Output Circuit

POTENTIAL APPLICATIONS FOR GPIO PINS

In addition to being useful debug tools while bringing a DES design up, there are other practical uses to which the GPIO pins can be put:

Automatic Switching To Secondary Input If The Signal On The Primary Input Is Lost

By setting GPIO₀ to monitor the status of input0 when there is a signal present on input 0, the GPIO₀ pin will go low when there is no signal present on the Input0 pin, if this signal is inverted and then used to drive the RX_MUX_SEL then if the input on Input0 is lost, the device will automatically switch to Input1.

Another possible use of the GPIO pins is to provide access to external signals such as the CD output from an equalizer or the LOCK output from the DES itself via the SMBus, helping to minimize the number of connections between the DES and the FPGA.

APPLICATION INFORMATION

PCB LAYOUT RECOMMENDATIONS

In almost all applications, the inputs to the DES will be driven by the output of an equalizer such as the LMH0044. You should follow the recommendations on the equalizer datasheet for the interface between the input connector and the equalizer—the DES will be placed between the equalizer and the FPGA. If the DES is too close to the equalizer, then there is a risk of crosstalk between the high speed digital outputs of the DES and the equalizer inputs. Conversely, if too far away then the interconnect between the equalizer and the DES may either pick up stray noise, or may broadcast noise since this is a very high speed signal. Be certain to treat the signal from the equalizer to the DES as a differential trace. If there is skew between the two conductors of the differential trace, not only might this cause difficulties for the DES receive circuitry, but having a phase difference between the sides of the pair makes the signal look and radiate like a common mode signal.

If the loopthrough output is going to be used, it is advised that the DES be placed close to the Loopthrough output BNC connector, and the equalizer be placed close to the SDI Input BNC connector. This will minimize the lengths of the most critical connections.

The DES includes a cable driver for the loopthrough output. The SMPTE Serial specifications have very stringent requirements for output return loss on drivers. The output return loss will be degraded by non-idealities in the connection between the DES and the output connector. All efforts should be taken to minimize the trace lengths for this area, and to assure that the characteristic impedance of this trace is 75Ω. The 75Ω termination resistor should be placed as close to the loopthrough output pin as is practicable.

It is recommended that the PCB traces between the host FPGA and the DES be no longer than 10 inches (25cm) and that the traces be routed as differential pairs, with very tight matching of line lengths and coupling within a pair, as well as equal length traces for each of the six pairs.

PCB DESIGN DO'S AND DON'TS

DO Whenever possible dedicate an entire layer to each power supply whenever possible—this will reduce the inductance in the supply plane.

DO use surface mount components whenever possible.

DO place bypass capacitors close to each power pin.

DON'T create ground loops—pay attention to the cutouts that are made in your power and ground planes to make sure that there are not opportunities for loops.

DON'T allow discontinuities in the ground planes—return currents will follow the path of least resistance—for high frequency signals this will be the path of least inductance.

DO place the Loopthrough outputs as close as possible to the edge of the PCB where it will connect to the outside world.

DO make sure to match the trace lengths of all differential traces, both between the sides of an individual pair, and from pair to pair.

DO remember that VIAs have significant inductance—when using a via to connect to a power supply or ground layer, two in parallel are better than one.

DO connect the slug on the bottom of the package to a solid Ground connection. This contact is used for the major GND connection to the device as well as serving as a thermal via to keep the die at a low operating temperature.

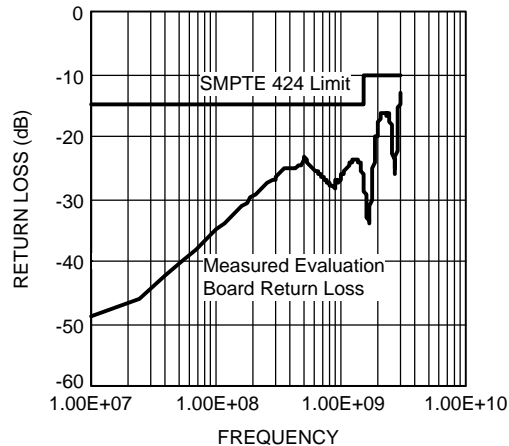

Figure 16. Evaluation Board Loopthrough Output Return Loss

TYPICAL SMPTE APPLICATIONS CIRCUIT

A typical application circuit for the DES is shown in [Figure 17](#). This circuit shows the LMH0341 3 Gbps deserializer, alternately this could employ the LMH0041 or LMH0071 deserializers in lower data rate SMPTE applications.

The RX interface between the DES and the host FPGA is composed of a 5-bit LVDS Data bus and its LVDS clock. This is a point-to-point interface. Line termination should be provided by the FPGA device. If not, and external 100Ω resistor maybe used and should be located as close to the FPGA as possible to minimize stub lengths. Pairs should be of equal length to minimize any skew impact. The LVDS clock (RXCLK) uses both edges to transfer the data.

An SMBus is also connected from the host FPGA to the DES. If the SMBus is shared, a chip select signal is used to select the device being addressed. The SCK and SDA signals require a pull up resistor. The SMB_CS is driven by a GPO signal from the FPGA. Depending on the FPGA I/O it may also require a pull up unless it is a push / pull output.

Depending upon the application, several other Host GPIO signals maybe used. This includes the DVB_ASI and RESET input signals. If these pins are not used, then must be tied off to the desired state. The LOCK signal maybe used to monitor the DES. If it is unused, leave the pin as a NC (or route to a test point).

Note also in this circuit, the LMH0341 GPIO_1 pin has been configured to provide the status of RXIN_1. When there is a signal present coming from the LMH0340, then RXIN_1 will be selected. If that signal is lost, the input MUX will automatically switch over to provide the system reference black signal as the input from RXIN_0.

The DES includes a SMPTE compliant cable driver for the Loopthrough function. While this is a differential driver, it is commonly used single-endedly to drive 75 Ω coax cables. External 75 Ω pull up resistors are used to the 2.5V rail. The active output(s) also includes a matching network to meet the required Output Return Loss SMPTE specification. While application specific, in general a series 75 Ω resistor shunted by a 6.8 nH inductor will provide a starting value to design with. The signal is then AC coupled to the cable with a 4.7 μF capacitor. If the complementary output is not used, simply terminate it after its AC coupling capacitor to ground. This output (even though its inverting) may still be used for a loop back or 1:2 function due to the nature of the NRZI coding that the SMPTE standards require. The output voltage amplitude of the cable driver is set by the R_{SET} resistor. For single-ended applications, an 7.87kΩ resistor is connected between this pin and ground to set the swing to 800mV.

The PLL loop filter is external for the SER. A capacitor is connected between the LF_CP and LF_REF pins. Typical value is 30 nF.

There are several configuration pins that requiring setting to the proper level. The RSVD_H pins should be pulled High to the 3.3V rail with a 5 kΩ resistor. Depending upon the application the DVB_ASI pin may be tied off or driven.

There are three supply connections (see bypass discussion in [POWER SUPPLIES](#) and also [PIN DESCRIPTIONS](#) for recommendations). The two main supplies are the 3.3V rail and the 2.5V rail. There is also a 3.3V connection for the PLL circuitry.

There are multiple Ground connections for the device. The main ground connection for the SER is through the large center DAP pad. This **must** be connected to ground for proper device operation. In addition, multiple other inputs are required to be connected to ground as show in [Figure 17](#) and listed in [PIN DESCRIPTIONS](#).

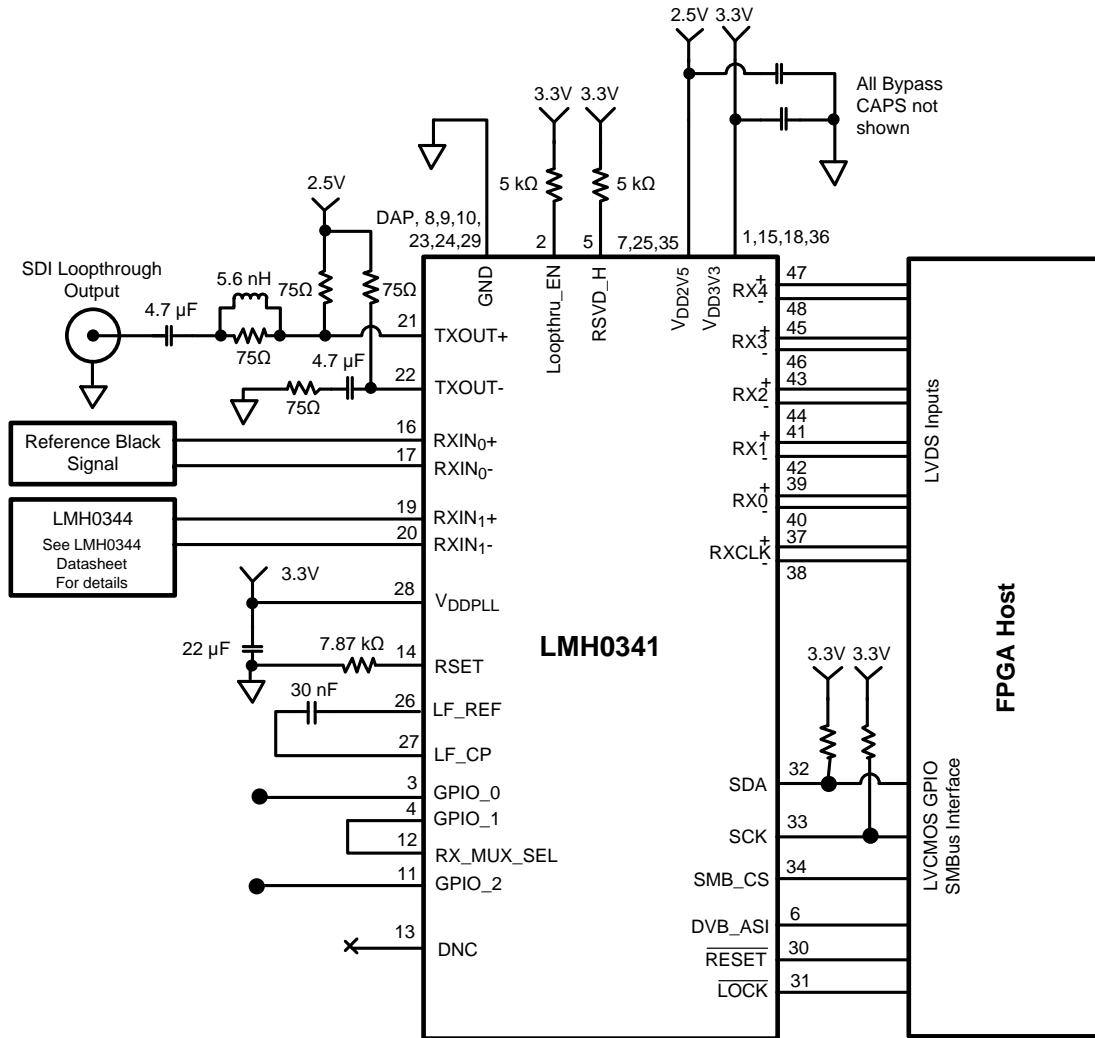

Figure 17. Typical SMPTE Application Circuit

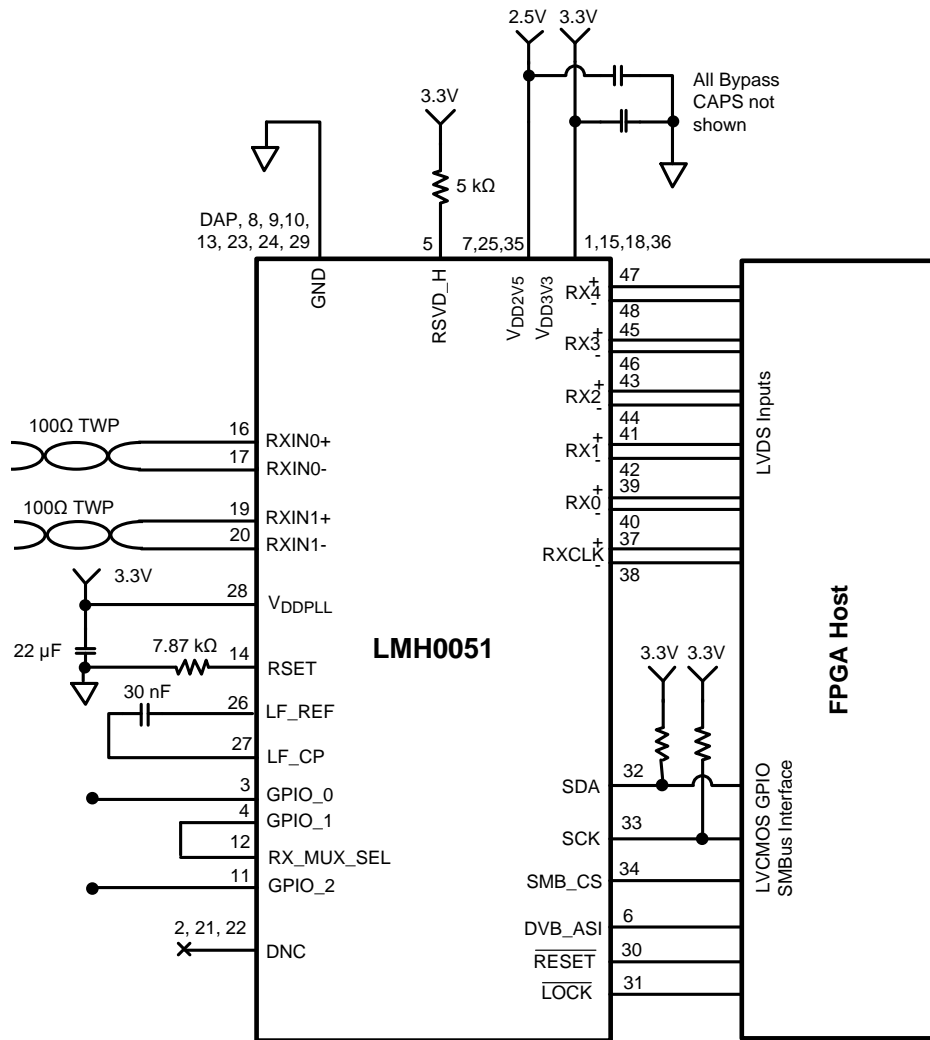

Figure 18. Typical CML Application Circuit (LMH0051)

REGISTER DESCRIPTIONS

Table 2 provides details on the device's configuration registers.

Table 2. DES Register Detail Table

| ADD 'h | Name | Bits | Field | R/W | Default | Description |
|--------|-----------------------|---|------------------|-----|---------|--|
| 00 | device_identification | The seven MSBs of this register define the SMBus address for the device. The default value is 0x58h, but this may be overwritten. The LSB of this register must always be '0' Note that since the address is shifted over by one bit, some systems may address the 058h as 'B0h | | | | |
| | | 7:1 | device_id | r/w | 058h | SMBus Device ID |
| | | 0 | reserved | | 0 | |
| 01 | reset | If a '1' is written into the LSB of register 0x01h then the device will do a soft reset, restoring it's internal state to the same as at powerup with the exception of the contents of register 0x00h, which if modified will remain unchanged | | | | |
| | | 7:1 | reserved | | | |
| | | 0 | sw_rst | r/w | 0'b | Software Reset |
| 02 | GPIO_0 Configuration | This register configures GPIO_0. Note, if this pin is to be used as an input, then the output must be TRI-STATE (bit[0]='0') and if used as an output, then the input buffer must be disabled (bit[1]='0'). | | | | |
| | | 7:4 | GPIO_0_mode[3:0] | r/w | 0000'b | 0000: GPout register 0001: signal detect 0 all others: reserved |
| | | 3:2 | GPIO_0_ren[1:0] | r/w | 01'b | 00: pullup and pulldown disabled 01: pulldown enabled 10: pullup enabled 11: Reserved |
| | | 1 | GPIO_0_sleepz | r/w | 0'b | 0: input buffer disabled 1: input buffer enabled |
| | | 0 | GPout0 enable | r/w | 1'b | 0: output TRI-STATE 1: output enabled |
| 03 | GPIO_1 Configuration | This register configures GPIO_1. Note, if this pin is to be used as an input, then the output must be TRI-STATE (bit[0]='0') and if used as an output, then the input buffer must be disabled (bit[1]='0'). | | | | |
| | | 7:4 | GPIO_0_mode[3:0] | r/w | 0000'b | 0000: POR 0001: GP_OUT[1] 0010: signal detect 1 0011: cdr_lock all others: reserved |
| | | 3:2 | GPIO_0_ren[1:0] | r/w | 01'b | 00: pullup and pulldown disabled 01: pulldown enabled 10: pullup enabled 11: Reserved |
| | | 1 | GPIO_0_sleepz | r/w | 0'b | 0: input buffer disabled 1: input buffer enabled |
| | | 0 | GPout0 enable | r/w | 1'b | 0: output TRI-STATE 1: output enabled |
| 04 | GPIO_2 Configuration | This register configures GPIO_2. Note, if this pin is to be used as an input, then the output must be TRI-STATE (bit[0]='0') and if used as an output, then the input buffer must be disabled (bit[1]='0'). | | | | |
| | | 7:4 | GPIO_0_mode[3:0] | r/w | 0000'b | 0000: GPout [2]register 0001: Always ON clock 0010: LVDS TX CLK 0011: CDR_CLK all others: reserved |
| | | 3:2 | GPIO_0_ren[1:0] | r/w | 01'b | 00: pullup and pulldown disabled 01: pulldown enabled 10: pullup enabled 11: Reserved |
| | | 1 | GPIO_0_sleepz | r/w | 0'b | 0: input buffer disabled 1: input buffer enabled |
| | | 0 | GPout0 enable | r/w | 1'b | 0: output TRI-STATE 1: output enabled |

Table 2. DES Register Detail Table (continued)

| ADD 'h | Name | Bits | Field | R/W | Default | Description |
|--------|----------------|--|---------------------|-----|-----------|--|
| 05 | GP Input | If any of the GPIO pins are configured as inputs, then reading from this register provides the values on those input pins | | | | |
| | | 7:3 | Reserved | | | |
| | | 2 | | r | | Input data on GPIO 2 |
| | | 1 | | r | | Input data on GPIO 1 |
| | | 0 | | r | | Input data on GPIO 0 |
| 06 | GP Output | If the GPIO ins are configured as General Purpose output pins, then writing to this register has the effect of transferring the bits in this register to the output buffers of the GPIO pins. | | | | |
| | | 7:3 | Reserved | | | |
| | | 2 | | r/w | | Output data on GPIO 2 |
| | | 1 | | r/w | | Output data on GPIO 1 |
| | | 0 | | r/w | | Output data on GPIO 0 |
| 07–0C | Reserved | | | | | |
| 0D | DVB_ASI Idle_A | When in DVB_ASI mode, idle characters are inserted into the datastream when there is no valid data to transmit. This character is recognized by the receiver. The default character is K28.5 but if desired that can be redefined via this register pair | | | | |
| | | 7:0 | | r/w | 83 | Data [7:0] |
| 0E | DVB_ASI Idle_B | DVB_ASI idle character MSBs | | | | |
| | | 7:2 | Reserved | | | |
| | | 1:0 | | r/w | 2 | Data[9:8] |
| 0F–1C | Reserved | | | | | |
| 1D | Variant | Reading from this register will return an 8 bit value which indicates which variant of the DES is being addressed | | | | |
| | | 7:6 | Reserved | r | | |
| | | 5 | Loop through enable | r | pin value | This bit returns the state of the loop-through enable, and defaults to the same as the state of the Loophthru_EN pin |
| | | 4:3 | mode | r | pin value | Returns a two bit pattern which indicates the state that the device is in 00,01,10: Standard Video Mode 11: DVB_ASI Mode |
| | | 2 | Reserved | | | |
| | | 1:0 | Variant | r | | returns the part type: 00: LMH0341 01: LMH0041/LMH0051 10:LMH0071 11:Reserved |
| 1E-1F | Reserved | | | | | |
| 20 | Control | 7:3 | Reserved | | | |
| | | 2 | Data Order | r/w | 0 | Determines deserialization order — 0: Expects LSB to be received first 1:Expects MSB to be received first |
| | | 1 | Reset Channel | r/w | 0 | Writing a '1' to this bit forces a reset of the channel |
| | | 0 | Digital Powerdown | r/w | 0 | Writing a '1' to this bit will shut down several of the digital processing sections of the product to save power. |
| 21 | DVB_ASI | This register allows the device to be placed in DVB_ASI mode or standard operation mode | | | | |
| | | 7:5 | Reserved | | | |
| | | 4 | RX_MUX_SEL | r/w | 0 | If enabled by register 22, then this bit will override the RX_MUX_SEL pin. |
| | | 3:2 | Reserved | | | |
| | | 1:0 | DVB_ASI | r/w | 0 | 00,01,10: Standard Operation 11: DVB_ASI |

Table 2. DES Register Detail Table (continued)

| ADD 'h | Name | Bits | Field | R/W | Default | Description |
|--------|---------------------|--|-------------------------|---------------------------|---|---|
| 22 | Override | This register allows the user to control the DVB_ASI and input select functions via the SMBus interface rather than the pin controls. | | | | |
| | | 7:5 | Reserved | | | |
| | | 4 | RX_MUX Control Override | r/w | 0 | Writing a '1' to this register allows register 21 to control the state of the input multiplexer — if the bit is set to '0' then the selection will be determined by the state of the RX_MUX_SEL pin |
| | | 3:1 | Reserved | | | |
| | 0 | DVB_ASI Override | | | Writing a '1' to this register allows register 21 to control the state of the DVB_ASI Select pin — if the bit is set to '0' then the selection will be determined by the state of the DVB_ASI pin if '1' then the contents of register 21 take precedence | |
| 23–26 | Reserved | | | | | |
| 27 | LVDS Control 1 | This register allows control of the LVDS output pins — using this register individual LVDS outputs can be enabled or disabled, and the outputs can be switched to high output mode | | | | |
| | | 7 | LVDS_VOD | r/w | 0 | With a '0' the V_{OD} of the LVDS output are as described in Electrical Characteristics , writing a '1' to this bit generates a larger V_{OD} allowing longer traces to be driven, and increasing total power dissipation |
| | | 6 | LVDS Control | r/w | 0 | Writing a '1' to this bit allows the LVDS outputs to be controlled via the SMBus |
| | | 5 | RXCLK Enable | r/w | 0 | Enables the RXCLK output driver |
| | | 4 | RX4 Enable | r/w | 0 | Enables RX4 output driver |
| | | 3 | RX3 Enable | r/w | 0 | Enables RX3 output driver |
| | | 2 | RX2 Enable | r/w | 0 | Enables RX2 output driver |
| | | 1 | RX1 Enable | r/w | 0 | Enables RX1 output driver |
| 0 | RX0 Enable | r/w | 0 | Enables RX0 output driver | | |
| 28 | LVDS Control 2 | More bits allowing control over the LVDS outputs | | | | |
| | | 7 | Reserved | | | |
| | | 6 | LVDS Reset | r/w | 0 | Resets LVDS Block |
| | | 5 | RXCLK Rate | r/w | 1 | 1: RXCLK is a DDR clock 0: RXCLK is at a rate of DDR/2 |
| | | 4 | RXCLK Invert | r/w | 0 | Inverts the polarity of the RXCLK signal |
| | | 3:2 | LVDS Clock delay | r/w | 10'b | Each LSB adds 80ps delay to the RXCLK signal path, allowing the setup and hold times to be adjusted. |
| 1:0 | Reserved | | | | | |
| 29–2A | Reserved | | | | | |
| 2B | Event Configuration | Allows control over the counting of error events on the clock recovery PLL | | | | |
| | | 7:4 | Reserved | | | |
| | | 3 | Event Count Select | r/w | 0 | 0: Select CDR Event counter for reading — events are counted for a loss of the RXCLK signal, or a loss of lock 1: Select data event counter |
| | | 2 | Reset CDR Error Count | r/w | 0 | Resets CDR Event count |
| | | 1 | Reset Link Error Count | r/w | 0 | resets data event counter |
| 0 | enable count | r/w | 0 | enables event counters | | |
| 2C | Reserved | | | | | |

Table 2. DES Register Detail Table (continued)

| ADD 'h | Name | Bits | Field | R/W | Default | Description |
|--------|-----------------|--|------------------------|-----|---------|--|
| 2D | Error Monitor | Controls Error Monitoring functions | | | | |
| | | 7:5 | Reserved | | | |
| | | 4 | Accumulate Error Count | r/w | 0 | Enable counting accumulation of errors |
| | | 3 | 8b10b error disable | r/w | 0 | When set, disables 8b10b errors from being counted, or from affecting the status of the LOCKpin |
| | | 2 | clear event count | r/w | 0 | When set, clears the number of errors in both the current and previous state of the error count |
| | | 1 | select error count | r/w | 0 | Select which error count to display 0: Number of errors in current run 1: Number of errors within the selected timing window |
| | | 0 | Normal Error Disable | r/w | 0 | Disable exiting NORMAL state when the number of errors exceeds the error threshold |
| 2E | Error Threshold | Sets the error threshold LSBs | | | | |
| | | 7:0 | Error Threshold | r/w | 0x10h | Error threshold above which the device stops receiving data and transferring it to the RXOUT pins. |
| 2F | Error Threshold | Sets the error threshold MSBs | | | | |
| | | | Error Threshold | r/w | 00 | Error threshold above which the device stops receiving data and transferring it to the RXOUT pins. |
| 30–3A | Reserved | | | | | |
| 3B | Data Rate | This Register provides information about the rate at which the receive PLL is locked | | | | |
| | | 7 | Reserved | | | |
| | | 6:4 | Freq Range | r | 111 | 001: 270 Mbps 011: 1.485 Gbps 110: 2.97 Gbps 111: Unlocked |
| | | 3:0 | Reserved | | | |
| 3C | CDR Lock Status | 7:4 | Reserved | | | |
| | | 3 | CDR Lock | r | | 1: CDR Locked 0: CDR Unlocked |
| | | 2 | Signal Detect Ch 1 | r | | 1: signal present |
| | | 1 | Signal Detect Ch 0 | r | | 1: signal present |
| | | 0 | Reserved | | | |
| 3D | Event Status | Error Counting register | | | | |
| | | 7:0 | event count | r/w | 0 | count of errors that caused a loss of the link |
| 3E | Error Status 1 | Error Count LSB | | | | |
| | | 7:0 | Data Error Count 1 | r/w | 0 | Number of errors in the data — LSB |
| 3F | Error Status 2 | Error Counting Register MSB | | | | |
| | | 7:0 | Data Error Count 2 | r/w | 0 | Number of errors in the data — MSB |

REVISION HISTORY

| Changes from Revision P (April 2013) to Revision Q | Page |
|--|--------------------|
| • Changed layout of National Data Sheet to TI format | 26 |

PACKAGING INFORMATION

| Orderable Device | Status (1) | Package Type | Package Drawing | Pins | Package Qty | Eco Plan (2) | Lead/Ball Finish (6) | MSL Peak Temp (3) | Op Temp (°C) | Device Marking (4/5) | Samples |
|------------------|---------------|--------------|-----------------|------|-------------|-------------------------|-------------------------|----------------------|--------------|-------------------------|-------------------------|
| LMH0041SQ/NOPB | ACTIVE | WQFN | RHS | 48 | 1000 | Green (RoHS & no Sb/Br) | CU SN | Level-3-260C-168 HR | -40 to 85 | LMH0041 | Samples |
| LMH0041SQE/NOPB | ACTIVE | WQFN | RHS | 48 | 250 | Green (RoHS & no Sb/Br) | CU SN | Level-3-260C-168 HR | -40 to 85 | LMH0041 | Samples |
| LMH0041SQX/NOPB | ACTIVE | WQFN | RHS | 48 | 2500 | Green (RoHS & no Sb/Br) | CU SN | Level-3-260C-168 HR | -40 to 85 | LMH0041 | Samples |
| LMH0051SQE/NOPB | ACTIVE | WQFN | RHS | 48 | 250 | Green (RoHS & no Sb/Br) | CU SN | Level-3-260C-168 HR | -40 to 85 | LMH0051 | Samples |
| LMH0071SQ/NOPB | ACTIVE | WQFN | RHS | 48 | 1000 | Green (RoHS & no Sb/Br) | CU SN | Level-3-260C-168 HR | -40 to 85 | LMH0071 | Samples |
| LMH0071SQE/NOPB | ACTIVE | WQFN | RHS | 48 | 250 | Green (RoHS & no Sb/Br) | CU SN | Level-3-260C-168 HR | -40 to 85 | LMH0071 | Samples |
| LMH0341SQ/NOPB | ACTIVE | WQFN | RHS | 48 | 1000 | Green (RoHS & no Sb/Br) | CU SN | Level-3-260C-168 HR | -40 to 85 | L0341 | Samples |
| LMH0341SQE/NOPB | ACTIVE | WQFN | RHS | 48 | 250 | Green (RoHS & no Sb/Br) | CU SN | Level-3-260C-168 HR | -40 to 85 | L0341 | Samples |
| LMH0341SQX/NOPB | ACTIVE | WQFN | RHS | 48 | 2500 | Green (RoHS & no Sb/Br) | CU SN | Level-3-260C-168 HR | -40 to 85 | L0341 | Samples |

(1) The marketing status values are defined as follows:

ACTIVE: Product device recommended for new designs.

LIFEBUY: TI has announced that the device will be discontinued, and a lifetime-buy period is in effect.

NRND: Not recommended for new designs. Device is in production to support existing customers, but TI does not recommend using this part in a new design.

PREVIEW: Device has been announced but is not in production. Samples may or may not be available.

OBSELETE: TI has discontinued the production of the device.

(2) Eco Plan - The planned eco-friendly classification: Pb-Free (RoHS), Pb-Free (RoHS Exempt), or Green (RoHS & no Sb/Br) - please check <http://www.ti.com/productcontent> for the latest availability information and additional product content details.

TBD: The Pb-Free/Green conversion plan has not been defined.

Pb-Free (RoHS): TI's terms "Lead-Free" or "Pb-Free" mean semiconductor products that are compatible with the current RoHS requirements for all 6 substances, including the requirement that lead not exceed 0.1% by weight in homogeneous materials. Where designed to be soldered at high temperatures, TI Pb-Free products are suitable for use in specified lead-free processes.

Pb-Free (RoHS Exempt): This component has a RoHS exemption for either 1) lead-based flip-chip solder bumps used between the die and package, or 2) lead-based die adhesive used between the die and leadframe. The component is otherwise considered Pb-Free (RoHS compatible) as defined above.

Green (RoHS & no Sb/Br): TI defines "Green" to mean Pb-Free (RoHS compatible), and free of Bromine (Br) and Antimony (Sb) based flame retardants (Br or Sb do not exceed 0.1% by weight in homogeneous material)

- (3) MSL, Peak Temp. - The Moisture Sensitivity Level rating according to the JEDEC industry standard classifications, and peak solder temperature.
- (4) There may be additional marking, which relates to the logo, the lot trace code information, or the environmental category on the device.
- (5) Multiple Device Markings will be inside parentheses. Only one Device Marking contained in parentheses and separated by a "~" will appear on a device. If a line is indented then it is a continuation of the previous line and the two combined represent the entire Device Marking for that device.
- (6) Lead/Ball Finish - Orderable Devices may have multiple material finish options. Finish options are separated by a vertical ruled line. Lead/Ball Finish values may wrap to two lines if the finish value exceeds the maximum column width.

Important Information and Disclaimer:The information provided on this page represents TI's knowledge and belief as of the date that it is provided. TI bases its knowledge and belief on information provided by third parties, and makes no representation or warranty as to the accuracy of such information. Efforts are underway to better integrate information from third parties. TI has taken and continues to take reasonable steps to provide representative and accurate information but may not have conducted destructive testing or chemical analysis on incoming materials and chemicals. TI and TI suppliers consider certain information to be proprietary, and thus CAS numbers and other limited information may not be available for release.

In no event shall TI's liability arising out of such information exceed the total purchase price of the TI part(s) at issue in this document sold by TI to Customer on an annual basis.

TAPE AND REEL INFORMATION



QUADRANT ASSIGNMENTS FOR PIN 1 ORIENTATION IN TAPE



*All dimensions are nominal

| Device | Package Type | Package Drawing | Pins | SPQ | Reel Diameter (mm) | Reel Width W1 (mm) | A0 (mm) | B0 (mm) | K0 (mm) | P1 (mm) | W (mm) | Pin1 Quadrant |
|-----------------|--------------|-----------------|------|------|--------------------|--------------------|---------|---------|---------|---------|--------|---------------|
| LMH0041SQ/NOPB | WQFN | RHS | 48 | 1000 | 330.0 | 16.4 | 7.3 | 7.3 | 1.3 | 12.0 | 16.0 | Q1 |
| LMH0041SQE/NOPB | WQFN | RHS | 48 | 250 | 178.0 | 16.4 | 7.3 | 7.3 | 1.3 | 12.0 | 16.0 | Q1 |
| LMH0041SQX/NOPB | WQFN | RHS | 48 | 2500 | 330.0 | 16.4 | 7.3 | 7.3 | 1.3 | 12.0 | 16.0 | Q1 |
| LMH0051SQE/NOPB | WQFN | RHS | 48 | 250 | 178.0 | 16.4 | 7.3 | 7.3 | 1.3 | 12.0 | 16.0 | Q1 |
| LMH0071SQ/NOPB | WQFN | RHS | 48 | 1000 | 330.0 | 16.4 | 7.3 | 7.3 | 1.3 | 12.0 | 16.0 | Q1 |
| LMH0071SQE/NOPB | WQFN | RHS | 48 | 250 | 178.0 | 16.4 | 7.3 | 7.3 | 1.3 | 12.0 | 16.0 | Q1 |
| LMH0341SQ/NOPB | WQFN | RHS | 48 | 1000 | 330.0 | 16.4 | 7.3 | 7.3 | 1.3 | 12.0 | 16.0 | Q1 |
| LMH0341SQE/NOPB | WQFN | RHS | 48 | 250 | 178.0 | 16.4 | 7.3 | 7.3 | 1.3 | 12.0 | 16.0 | Q1 |
| LMH0341SQX/NOPB | WQFN | RHS | 48 | 2500 | 330.0 | 16.4 | 7.3 | 7.3 | 1.3 | 12.0 | 16.0 | Q1 |

TAPE AND REEL BOX DIMENSIONS

*All dimensions are nominal

| Device | Package Type | Package Drawing | Pins | SPQ | Length (mm) | Width (mm) | Height (mm) |
|-----------------|--------------|-----------------|------|------|-------------|------------|-------------|
| LMH0041SQ/NOPB | WQFN | RHS | 48 | 1000 | 367.0 | 367.0 | 38.0 |
| LMH0041SQE/NOPB | WQFN | RHS | 48 | 250 | 210.0 | 185.0 | 35.0 |
| LMH0041SQX/NOPB | WQFN | RHS | 48 | 2500 | 367.0 | 367.0 | 38.0 |
| LMH0051SQE/NOPB | WQFN | RHS | 48 | 250 | 210.0 | 185.0 | 35.0 |
| LMH0071SQ/NOPB | WQFN | RHS | 48 | 1000 | 367.0 | 367.0 | 38.0 |
| LMH0071SQE/NOPB | WQFN | RHS | 48 | 250 | 210.0 | 185.0 | 35.0 |
| LMH0341SQ/NOPB | WQFN | RHS | 48 | 1000 | 367.0 | 367.0 | 38.0 |
| LMH0341SQE/NOPB | WQFN | RHS | 48 | 250 | 210.0 | 185.0 | 35.0 |
| LMH0341SQX/NOPB | WQFN | RHS | 48 | 2500 | 367.0 | 367.0 | 38.0 |

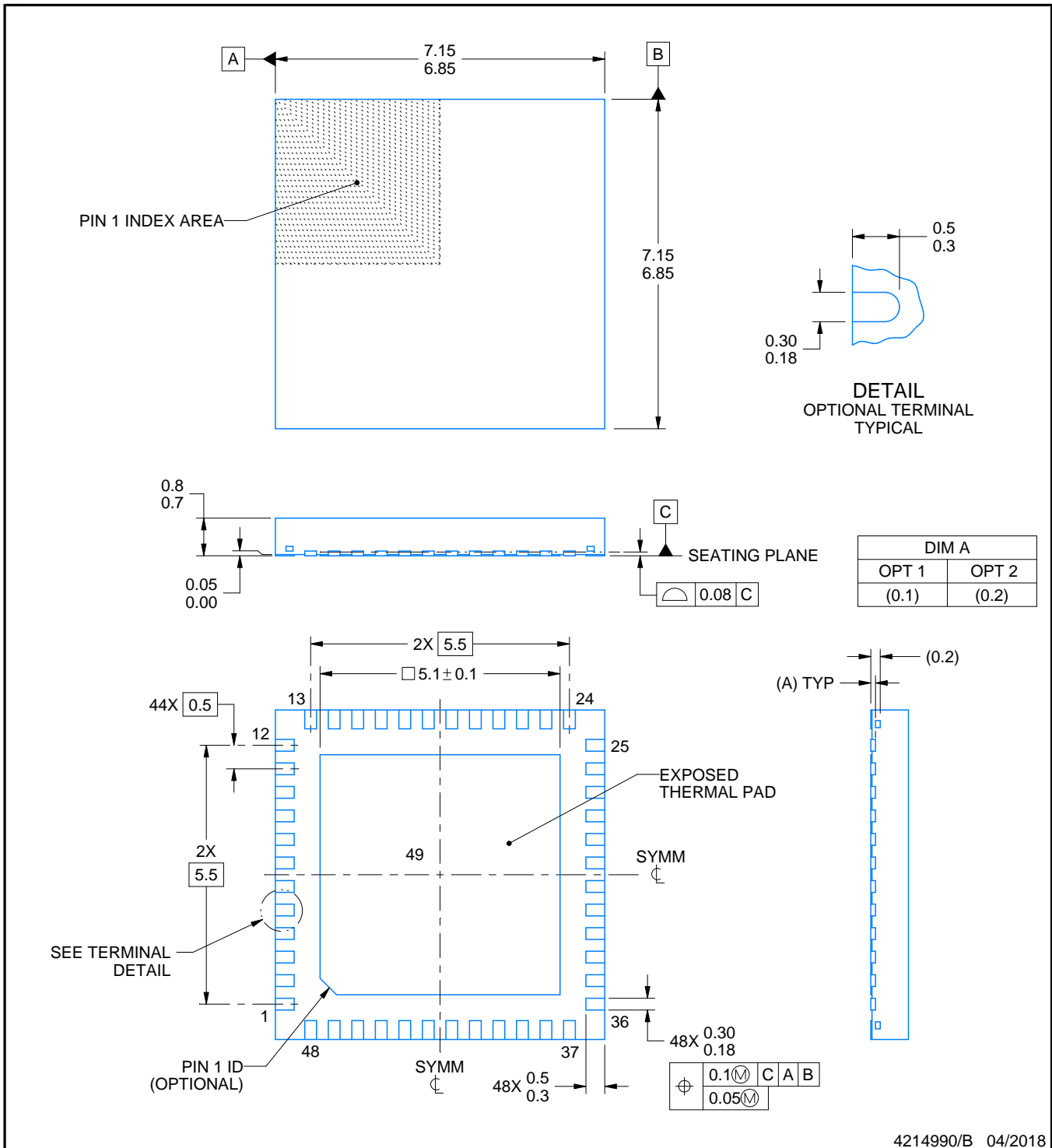
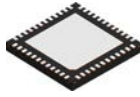

4214990/B 04/2018

NOTES:

1. All linear dimensions are in millimeters. Any dimensions in parenthesis are for reference only. Dimensioning and tolerancing per ASME Y14.5M.
2. This drawing is subject to change without notice.
3. The package thermal pad must be soldered to the printed circuit board for thermal and mechanical performance.

EXAMPLE STENCIL DESIGN

RHS0048A

WQFN - 0.8 mm max height

PLASTIC QUAD FLATPACK - NO LEAD

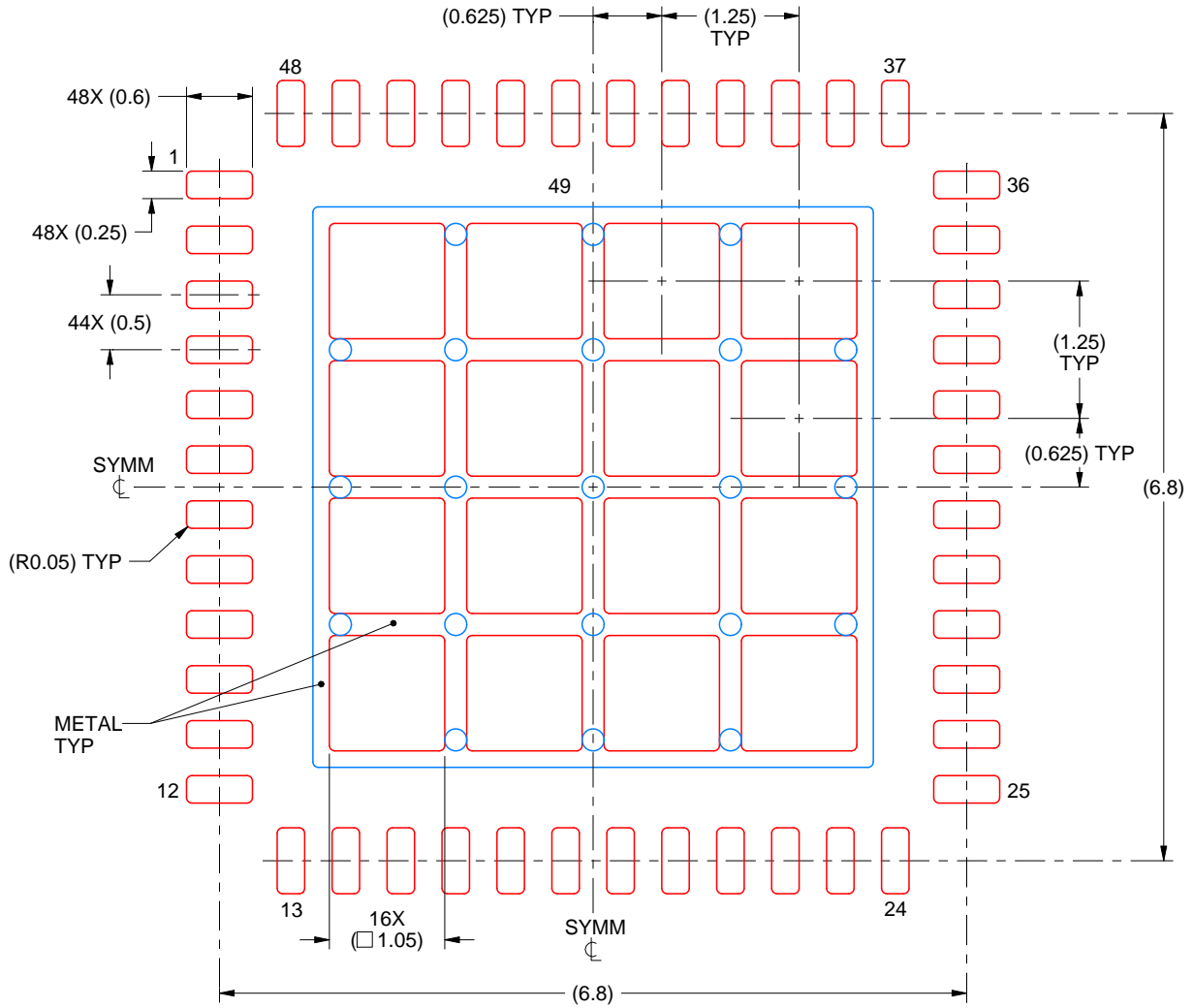

SOLDER PASTE EXAMPLE
 BASED ON 0.125 mm THICK STENCIL

EXPOSED PAD 49
 68% PRINTED SOLDER COVERAGE BY AREA UNDER PACKAGE
 SCALE:15X

4214990/B 04/2018

NOTES: (continued)

6. Laser cutting apertures with trapezoidal walls and rounded corners may offer better paste release. IPC-7525 may have alternate design recommendations.

IMPORTANT NOTICE

Texas Instruments Incorporated (TI) reserves the right to make corrections, enhancements, improvements and other changes to its semiconductor products and services per JESD46, latest issue, and to discontinue any product or service per JESD48, latest issue. Buyers should obtain the latest relevant information before placing orders and should verify that such information is current and complete.

TI's published terms of sale for semiconductor products (<http://www.ti.com/sc/docs/stdterms.htm>) apply to the sale of packaged integrated circuit products that TI has qualified and released to market. Additional terms may apply to the use or sale of other types of TI products and services.

Reproduction of significant portions of TI information in TI data sheets is permissible only if reproduction is without alteration and is accompanied by all associated warranties, conditions, limitations, and notices. TI is not responsible or liable for such reproduced documentation. Information of third parties may be subject to additional restrictions. Resale of TI products or services with statements different from or beyond the parameters stated by TI for that product or service voids all express and any implied warranties for the associated TI product or service and is an unfair and deceptive business practice. TI is not responsible or liable for any such statements.

Buyers and others who are developing systems that incorporate TI products (collectively, "Designers") understand and agree that Designers remain responsible for using their independent analysis, evaluation and judgment in designing their applications and that Designers have full and exclusive responsibility to assure the safety of Designers' applications and compliance of their applications (and of all TI products used in or for Designers' applications) with all applicable regulations, laws and other applicable requirements. Designer represents that, with respect to their applications, Designer has all the necessary expertise to create and implement safeguards that (1) anticipate dangerous consequences of failures, (2) monitor failures and their consequences, and (3) lessen the likelihood of failures that might cause harm and take appropriate actions. Designer agrees that prior to using or distributing any applications that include TI products, Designer will thoroughly test such applications and the functionality of such TI products as used in such applications.

TI's provision of technical, application or other design advice, quality characterization, reliability data or other services or information, including, but not limited to, reference designs and materials relating to evaluation modules, (collectively, "TI Resources") are intended to assist designers who are developing applications that incorporate TI products; by downloading, accessing or using TI Resources in any way, Designer (individually or, if Designer is acting on behalf of a company, Designer's company) agrees to use any particular TI Resource solely for this purpose and subject to the terms of this Notice.

TI's provision of TI Resources does not expand or otherwise alter TI's applicable published warranties or warranty disclaimers for TI products, and no additional obligations or liabilities arise from TI providing such TI Resources. TI reserves the right to make corrections, enhancements, improvements and other changes to its TI Resources. TI has not conducted any testing other than that specifically described in the published documentation for a particular TI Resource.

Designer is authorized to use, copy and modify any individual TI Resource only in connection with the development of applications that include the TI product(s) identified in such TI Resource. NO OTHER LICENSE, EXPRESS OR IMPLIED, BY ESTOPPEL OR OTHERWISE TO ANY OTHER TI INTELLECTUAL PROPERTY RIGHT, AND NO LICENSE TO ANY TECHNOLOGY OR INTELLECTUAL PROPERTY RIGHT OF TI OR ANY THIRD PARTY IS GRANTED HEREIN, including but not limited to any patent right, copyright, mask work right, or other intellectual property right relating to any combination, machine, or process in which TI products or services are used. Information regarding or referencing third-party products or services does not constitute a license to use such products or services, or a warranty or endorsement thereof. Use of TI Resources may require a license from a third party under the patents or other intellectual property of the third party, or a license from TI under the patents or other intellectual property of TI.

TI RESOURCES ARE PROVIDED "AS IS" AND WITH ALL FAULTS. TI DISCLAIMS ALL OTHER WARRANTIES OR REPRESENTATIONS, EXPRESS OR IMPLIED, REGARDING RESOURCES OR USE THEREOF, INCLUDING BUT NOT LIMITED TO ACCURACY OR COMPLETENESS, TITLE, ANY EPIDEMIC FAILURE WARRANTY AND ANY IMPLIED WARRANTIES OF MERCHANTABILITY, FITNESS FOR A PARTICULAR PURPOSE, AND NON-INFRINGEMENT OF ANY THIRD PARTY INTELLECTUAL PROPERTY RIGHTS. TI SHALL NOT BE LIABLE FOR AND SHALL NOT DEFEND OR INDEMNIFY DESIGNER AGAINST ANY CLAIM, INCLUDING BUT NOT LIMITED TO ANY INFRINGEMENT CLAIM THAT RELATES TO OR IS BASED ON ANY COMBINATION OF PRODUCTS EVEN IF DESCRIBED IN TI RESOURCES OR OTHERWISE. IN NO EVENT SHALL TI BE LIABLE FOR ANY ACTUAL, DIRECT, SPECIAL, COLLATERAL, INDIRECT, PUNITIVE, INCIDENTAL, CONSEQUENTIAL OR EXEMPLARY DAMAGES IN CONNECTION WITH OR ARISING OUT OF TI RESOURCES OR USE THEREOF, AND REGARDLESS OF WHETHER TI HAS BEEN ADVISED OF THE POSSIBILITY OF SUCH DAMAGES.

Unless TI has explicitly designated an individual product as meeting the requirements of a particular industry standard (e.g., ISO/TS 16949 and ISO 26262), TI is not responsible for any failure to meet such industry standard requirements.

Where TI specifically promotes products as facilitating functional safety or as compliant with industry functional safety standards, such products are intended to help enable customers to design and create their own applications that meet applicable functional safety standards and requirements. Using products in an application does not by itself establish any safety features in the application. Designers must ensure compliance with safety-related requirements and standards applicable to their applications. Designer may not use any TI products in life-critical medical equipment unless authorized officers of the parties have executed a special contract specifically governing such use. Life-critical medical equipment is medical equipment where failure of such equipment would cause serious bodily injury or death (e.g., life support, pacemakers, defibrillators, heart pumps, neurostimulators, and implantables). Such equipment includes, without limitation, all medical devices identified by the U.S. Food and Drug Administration as Class III devices and equivalent classifications outside the U.S.

TI may expressly designate certain products as completing a particular qualification (e.g., Q100, Military Grade, or Enhanced Product). Designers agree that it has the necessary expertise to select the product with the appropriate qualification designation for their applications and that proper product selection is at Designers' own risk. Designers are solely responsible for compliance with all legal and regulatory requirements in connection with such selection.

Designer will fully indemnify TI and its representatives against any damages, costs, losses, and/or liabilities arising out of Designer's non-compliance with the terms and provisions of this Notice.

Looking for pricing, stock, or lifecycle information?

Click below to explore more details on WIN SOURCE:

 [View LMH0071SQE/NOPB on WIN SOURCE](#)

 [Texas Instruments](#) Information

Optimize Your Supply Chain with WIN SOURCE Solutions

-  Global Sourcing Solution
-  Obsolete Management
-  Cost Control Management
-  Shortage Management
-  Alternative Solution
-  Excess Inventory Management