



THE DATASHEET OF GRDBAR600



GRDBAR- SERIES

BUL10415

REV. A

ASSEMBLY INSTRUCTIONS FOR GRDBAR - HME GROUND BAR

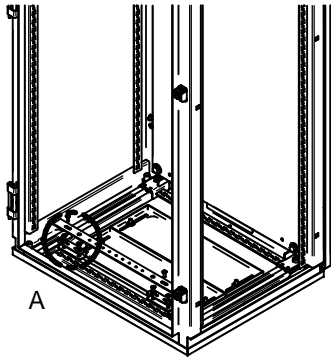

A

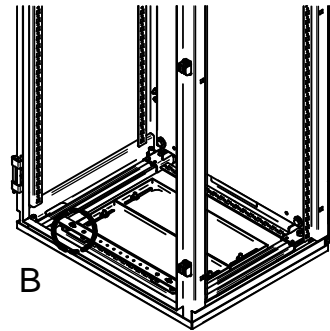

B

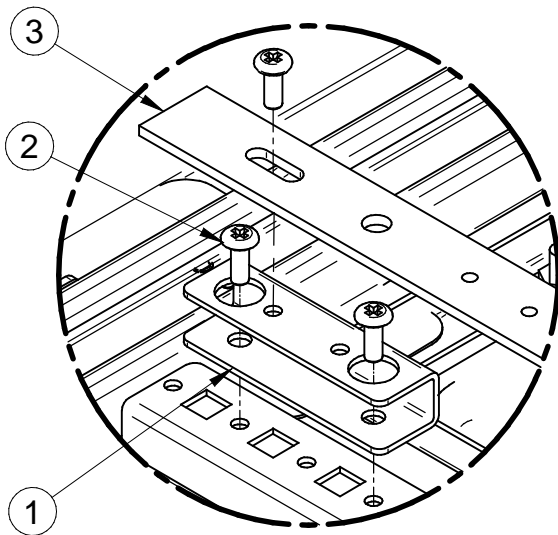

DETAIL A
TYP
BOTH SIDES

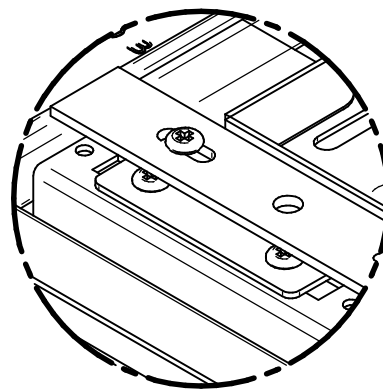

DETAIL B
TYP
BOTH SIDES

INSTRUCTIONS:

A) ALIGN SPACER BRACKETS (ITEM#1) TO ROUND HOLES IN FRAME AS SHOWN (SECOND HOLE FROM EDGE), (SEE DETAIL A).

B) SECURE BRACKETS TO FRAME USING SCREWS (ITEM #2).

C) ALIGN HORIZONTAL GROUND BAR (ITEM#3) TO ROUND HOLES IN SPACER BRACKET AS SHOWN AND SECURE USING SCREWS.

****NOTE: GROUND BAR CAN BE MOUNTED LEFT TO RIGHT AT THE FRONT OR REAR OF THE FRAME****

ITEM	DESCRIPTION	QTY
1	SPACER BRACKET	2
2	SCREW #12X1/2 PAN HEAD PH	6
3	HORIZ. GROUND BAR	1

TOOL BOX





Phillips
Screw Driver



**HAMMOND
MANUFACTURING™**
www.hammondmfg.com

Looking for pricing, stock, or lifecycle information?

Click below to explore more details on WIN SOURCE:

-  [View GRDBAR600 on WIN SOURCE](#)
-  [Hammond Manufacturing Information](#)

Optimize Your Supply Chain with WIN SOURCE Solutions

-  Global Sourcing Solution
-  Obsolete Management
-  Cost Control Management
-  Shortage Management
-  Alternative Solution
-  Excess Inventory Management