

AN7125

Dual Channel BTL Power Amplifier

■ Overview

AN7125 is a monolithic integrated circuit designed for 13.5 W (12 V, 4 Ω) output audio power amplifier. It is a dual channel BTL IC suitable for stereo operation in radio cassette and TV application.

■ Features

- Built-in muting pin
- Built-in stand by pin
- Built-in thermal shutdown protection circuit
- Built-in current limiting circuit
- High power : (13.5 W/12 V/4 Ω)
(13.0 W/15 V/8 Ω)
- Few external components
- Operating voltage range 6 V ~ 18 V (12 V typ.)

■ Applications

- Radio-cassette

■ Block Diagram

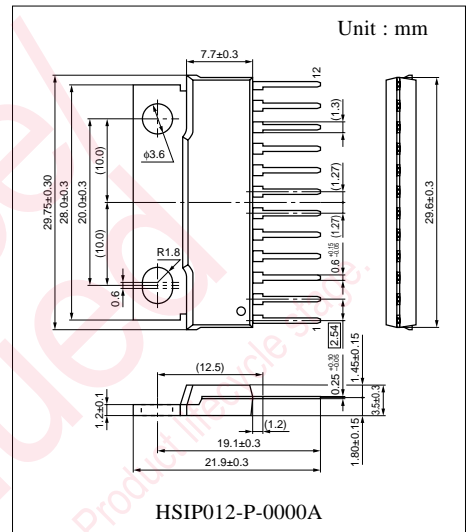
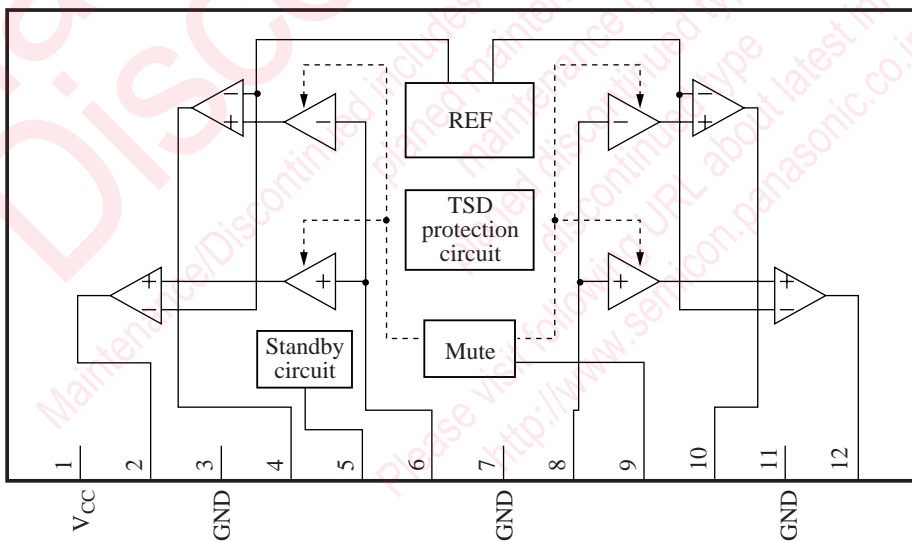

■ Pin Descriptions

Pin No.	Description	Pin No.	Description
1	V _{CC}	7	Pre GND
2	ch.1 +ve Phase Output	8	ch.2 Input
3	ch.1 Output GND	9	Mute
4	ch.1 -ve Phase Output	10	ch.2 -ve Phase Output
5	Standby	11	ch.2 Output GND
6	ch.1 Input	12	ch.2 +ve Phase Output

■ Absolute Maximum Ratings

Parameter	Symbol	Ratings	Unit
Supply voltage *1	V _{CC}	24	V
Supply current	I _{CC}	6.0	A
Power dissipation *2	P _D	38.5	W
Operating ambient temperature	T _{opr}	-25 to +75	°C
Storage temperature	T _{stg}	-55 to +150	°C

Note) *1 : Without input signal, V_{CC} is up to 24 V

*2 : T_a = 75 °C.

■ Recommended Operating Range

Parameter	Symbol	Range	Unit
Supply voltage	V _{CC}	6.0 to 18.0	V

■ Electrical Characteristics at V_{CC} = 12 V, R_L = 4 Ω, freq. = 1 kHz, 2 channel outputs, T_a = 25 °C

Parameter	Symbol	Conditions	Min	Typ	Max	Unit
Quiescent circuit current	I _{CQ}	V _{IN} = 0 mV	—	100	210	mA
Output noise voltage *1	V _{NO}	V _{IN} = 0 mV, R _G = 6.2 kΩ	—	0.27	0.5	mVrms
Voltage gain	G _{VC}	V _{IN} = 20 mV	38	40	42	dB
Total harmonic distortion *2	THD	V _{IN} = 20 mV	—	0.07	0.4	%
Maximum output power	P _O	THD = 10 %	10	12	—	W
Channel balance	CB	V _{IN} = 20 mV	-1	0	1	dB
Channel crosstalk *2	CT	V _{IN} = 20 mV, R _G = 6.2 kΩ	55	70	—	dB
Output offset voltage	V _{OFF}	R _G = 6.2 kΩ	-350	0	350	mV
Ripple rejection *1	RR	V _R = 1 V _{rms} , f _R = 120 Hz, R _G = 6.2 kΩ	50	60	—	dB
Standby current	I _{STB}	V _{IN} = 0 mV	—	1	10	μA
Muting effects *2	MT	V _{IN} = 20 mV	70	80	—	dB

Note) *1 : With a filter band 20 Hz to 20 kHz (12 dB/OCT) used.

*2 : With a filter band 400 Hz to 30 kHz used.

■ Terminal Equivalent Circuit

Pin No.	Equivalent Circuit	Function	Status
1	—	V _{CC} : V _{CC} input	typ. : 12 V
2		ch.1 O/P : ch.1 positive phase output pin.	V _{CC} /2
3		ch.1 Power GND : ch.1 output power ground pin.	0 V
4		ch.1 O/P : ch.1 inverse phase output pin.	V _{CC} /2
5		Standby : This is the standby control pin. STB off > 3.5 V STB on = 0 V/GND	V _{TH} = 2.8 V
6		ch.1 Input : This is the amplifier input pin.	0 V
7	—	Pre GND : Input ground pin.	0 V

■ Terminal Equivalent Circuit(continued)

Pin No.	Equivalent Circuit	Function	Status
8		ch.2 Input : This is the amplifier input pin.	0 V
9		Mute : Mute input pin. Mute on > 2.5 V Mute off = 0 V	$V_{TH} = 1.5 V$
10		ch.2 Output : ch.2 inverse phase output pin	$V_{CC}/2$
11		ch.2 Power GND : ch.2 output power ground	0 V
12		ch.2 Output : ch.2 positive phase output pin	$V_{CC}/2$

■ Application Circuit Example

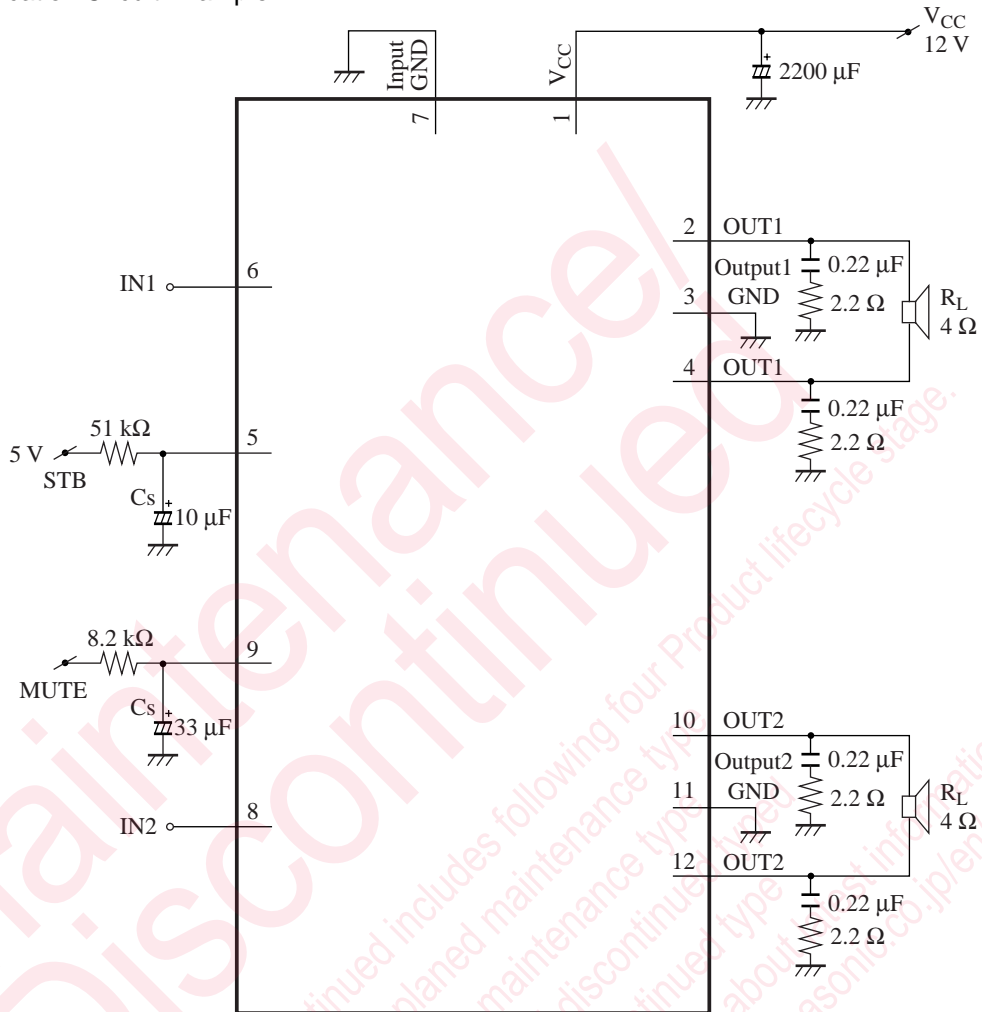

STB 'Off'	5 V
STB 'On'	0 V
Mute 'Off'	0 V
Mute 'On'	5 V

■ Application 's Precautions

1. External heatsink is needed when used. External heatsink should be fixed to the chassis.
2. Fin of the IC can be connected to GND.
3. Please prevent output to V_{CC} short and output to GND short.
4. The temperature protection circuit will operate at T_j around 150 °C.

However, if temperature decrease, the protection circuit will automatically be decreased and resume normal operation.

■ Technical Information

- HSIP012-P-0000A

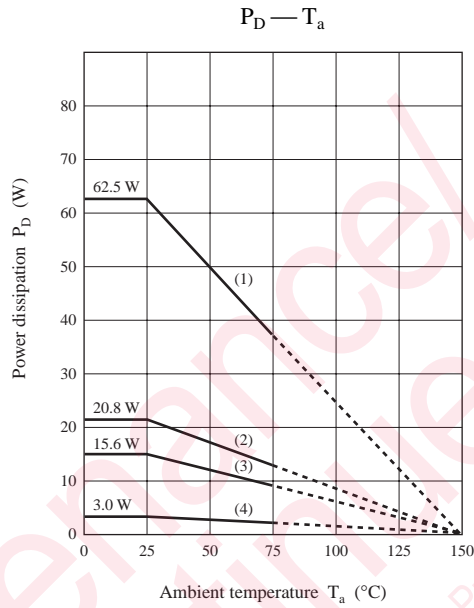

1. $T_C = T_a, 62.5 \text{ W}$ ($\theta_{j-c} = 2 \text{ }^\circ\text{C/W}$)
2. 20.83 W ($\theta_f = 4.0 \text{ }^\circ\text{C/W}$)
With a $100 \text{ cm}^2 \times 3 \text{ mm}$ Al heat sink (black colour coated) or a $200 \text{ cm}^2 \times 2 \text{ mm}$ Al heat sink (not lacquered)
3. 15.63 W ($\theta_f = 6.0 \text{ }^\circ\text{C/W}$)
With a $100 \text{ cm}^2 \times 2 \text{ mm}$ Al heat sink (not lacquered)
4. 3.0 W at $T_a = 25 \text{ }^\circ\text{C}$ ($\theta_{j-a} = 42 \text{ }^\circ\text{C/W}$)
Without heat sink

- Area of safe operation

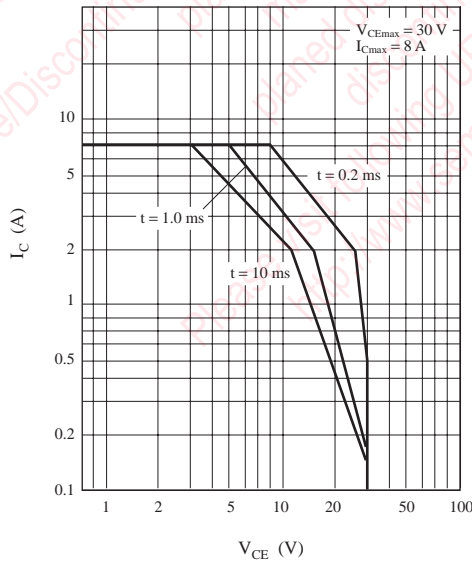

utions in using the technical information and scribed in this book

s book is to be exported or provided to non-residents, the laws and
rd to security export control, must be observed.

ly to show the main characteristics and application circuit examples
l property right or other right owned by our company or any other
any as to the infringement upon any such right owned by any other
rmation described in this book.

standard applications or general electronic equipment (such as office
and household appliances).

ng applications:

biles, traffic control equipment, combustion equipment, life support
reliability are required, or if the failure or malfunction of the prod-

ck are subject to change without notice for modification and/or im-
use of the products, therefore, ask for the most up-to-date Product
atisfy your requirements.

bsolute maximum rating and the guaranteed operating conditions
(.). Especially, please be careful not to exceed the range of absolute
er-off and mode-switching. Otherwise, we will not be liable for any

take into the consideration of incidence of break down and failure
n the systems such as redundant design, arresting the spread of fire
al injury, fire, social damages, for example, by using the products.

own and characteristics change due to external factors (ESD, EOS,
mounting or at customer's process. When using products for which
shelf life and the elapsed time since first opening the packages.

ly or partially, without the prior written permission of Matsushita

Looking for pricing, stock, or lifecycle information?

Click below to explore more details on WIN SOURCE:

 [View AN7125 on WIN SOURCE](#)

 [Panasonic Information](#)

Optimize Your Supply Chain with WIN SOURCE Solutions

-  Global Sourcing Solution
-  Obsolete Management
-  Cost Control Management
-  Shortage Management
-  Alternative Solution
-  Excess Inventory Management