



**THE DATASHEET OF  
LT2940CMS#PBF**



## FEATURES

- Four-Quadrant Power Measurement
- $\pm 5\%$  Power Measurement Accuracy
- 4V to 80V High Side Sense, 100V Max
- Current Mode Power and Current Outputs
- Output Bandwidth Exceeds 500kHz
- $\pm 3\%$  Current Measurement Accuracy
- 6V to 80V Supply Range, 100V Max
- Inverting and Noninverting Open-Collector Comparator Outputs
- Available in 12-Pin DFN (3mm  $\times$  3mm) and 12-Lead MSOP Packages

## APPLICATIONS

- Board Level Power and Current Monitoring
- Line Card and Server Power Monitoring
- Power Sense Circuit Breaker
- Power Control Loops
- Power/Energy Meters
- Battery Charger Metering

## DESCRIPTION

The LT<sup>®</sup>2940 measures a high side current and a differential voltage, multiplies them and outputs a current proportional to instantaneous power. Bidirectional high side currents and bipolar voltage differences are correctly handled by the four-quadrant multiplier and push-pull output stage, which allows the LT2940 to indicate forward and reverse power flow.

An integrated comparator with inverting and noninverting open-collector outputs makes the LT2940 a complete power level monitor. In addition, an output current proportional to the sensed high side current allows current monitoring. The current mode outputs make scaling, filtering and time integration as simple as selecting external resistors and/or capacitors.

LT, LT, LTC, LTM, Linear Technology and the Linear logo are registered trademarks of Linear Technology Corporation. All other trademarks are the property of their respective owners.

## TYPICAL APPLICATION

Load Monitor Alarms Above 60W

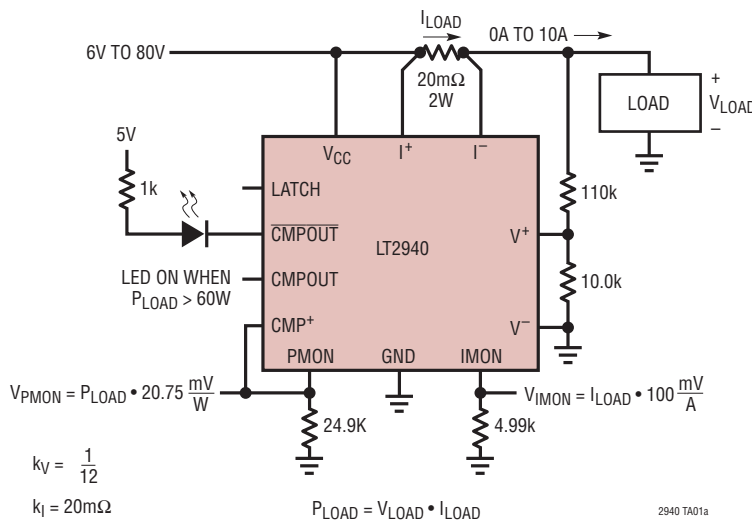

Monitor Output Level and Load Power

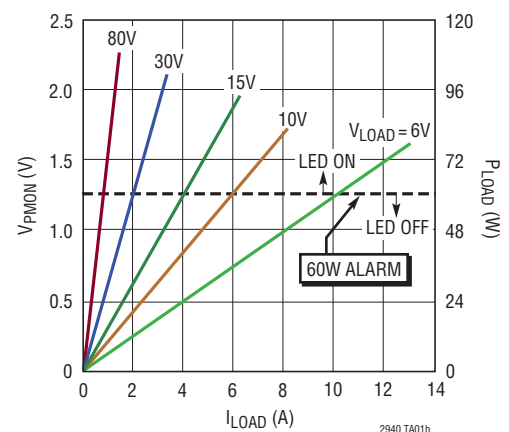

# LT2940

## ABSOLUTE MAXIMUM RATINGS (Notes 1, 2)

$V_{CC}$ , $I^+$ , $I^-$ , LATCH	-0.3V to 100V
$V^+$ , $V^-$ , CMP+	-0.3V to 36V
Voltage Sense ( $V^+ - V^-$ )	$\pm 36V$
Current Sense ( $I^+ - I^-$ )	$\pm 36V$
PMON, IMON (Note 3)	-0.3V to $V_{CC} + 1V$ , Up to 16V
CMPOUT, $\overline{CMPOUT}$	-0.3V to 36V
CMPOUT, $\overline{CMPOUT}$ DC Output Current	22mA

Operating Temperature Range	
LT2940C	0°C to 70°C
LT2940I	-40°C to 85°C
Storage Temperature Range	-65°C to 150°C
Lead Temperature (Soldering, 10 sec)	
MSOP Package	300°C

## PIN CONFIGURATION

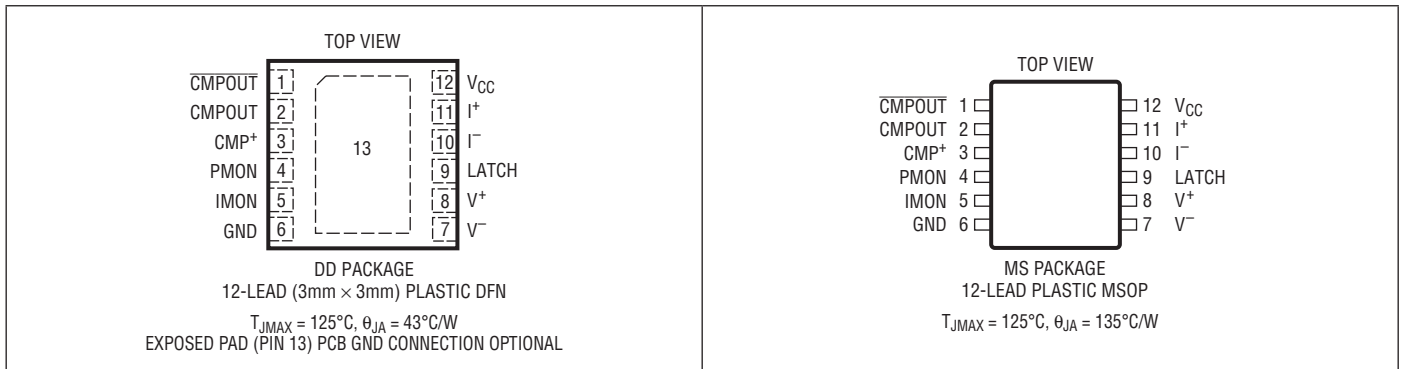

## ORDER INFORMATION

LEAD FREE FINISH	TAPE AND REEL	PART MARKING*	PACKAGE DESCRIPTION	TEMPERATURE RANGE
LT2940CDD#PBF	LT2940CDD#TRPBF	LDPP	12-Lead Plastic DFN	0°C to 70°C
LT2940IDD#PBF	LT2940IDD#TRPBF	LDPP	12-Lead Plastic DFN	-40°C to 85°C
LT2940CMS#PBF	LT2940CMS#TRPBF	2940	12-Lead Plastic MSOP	0°C to 70°C
LT2940IMS#PBF	LT2940IMS#TRPBF	2940	12-Lead Plastic MSOP	-40°C to 85°C

Consult LTC Marketing for parts specified with wider operating temperature ranges. \*The temperature grade is identified by a label on the shipping container.

For more information on lead free part marking, go to: <http://www.linear.com/leadfree/>

For more information on tape and reel specifications, go to: <http://www.linear.com/tapeandreeel/>

**ELECTRICAL CHARACTERISTICS** The ● denotes the specifications which apply over the full operating temperature range, otherwise specifications are at  $T_A = 25^\circ\text{C}$ . All specifications apply at  $6\text{V} \leq V_{CC} \leq 80\text{V}$ , unless otherwise specified.

SYMBOL	PARAMETER	CONDITIONS		MIN	TYP	MAX	UNITS
<b>Supply</b>							
$V_{CC}$	Supply Voltage Operating Range		●	6		80	V
$I_{CC}$	Supply Current	$I_{PMON} = +200\mu\text{A}$ , $I_{IMON} = +200\mu\text{A}$ (Note 2)	●	2	3.5	5	mA
$V_{CC(UVLC)}$	Supply Undervoltage Latch Clear	$V_{CC}$ Falling	●	2.3	2.5	2.7	V
$\Delta V_{CC(HYST)}$	Supply Undervoltage Hysteresis	$V_{CC}$ Rising	●	20	75	100	mV
<b>Voltage Sense</b>							
$V_{VSEN(OR)}$	Voltage Sense Pin Operating Range  $V^+$ Pin and $V^-$ Pin	$V_{CC} \leq 12\text{V}$	●	-0.1		$V_{CC} - 3$	V
		$12\text{V} < V_{CC} < 30\text{V}$	●	-0.1		9	V
		$V_{CC} \geq 30\text{V}$	●	-0.1		18	V
$V_V$	Voltage Sense Differential Input Voltage Range (Note 5) $V_V = V_{V+} - V_{V-}$	$V_{CC} < 11\text{V}$	●	$\pm(V_{CC} - 3)$			V
		$V_{CC} \geq 11\text{V}$	●	$\pm 8$			V
$V_{V(CL)}$	Voltage Sense Differential Clipping Limit (Note 5)	$V_{CC} \geq 12\text{V}$	●	$\pm 9$			V
$I_{VSEN}$	Voltage Sense Input Bias Current $V^+$ Pin and $V^-$ Pin		●	-300	-100	100	nA
$\Delta I_{VSEN}$	Voltage Sense Input Offset Current $\Delta I_{VSEN} = I_{V+} - I_{V-}$	$V_{V+} = V_{V-}$	●		$\pm 50$	$\pm 150$	nA
<b>Current Sense</b>							
$V_{ISEN(OR)}$	Current Sense Pin Operating Range $I^+$ Pin and $I^-$ Pin		●	4		80	V
$V_I$	Current Sense Differential Input Voltage Range (Note 6) $V_I = V_{I+} - V_{I-}$		●	$\pm 200$			mV
$V_{I(CL)}$	Current Sense Differential Clipping Limit (Note 6)		●	$\pm 225$			mV
$I_{ISEN}$	Current Sense Input Bias Current $I^+$ Pin and $I^-$ Pin		●	75	100	125	$\mu\text{A}$
$\Delta I_{ISEN}$	Current Sense Input Offset Current $\Delta I_{ISEN} = I_{I+} - I_{I-}$	$V_{I+} = V_{I-}$	●		$\pm 200$	$\pm 800$	nA
<b>Power Monitor (Note 2)</b>							
$I_{PMON(OR)}$	Power Monitor Output Current Operating Range		●	$\pm 200$			$\mu\text{A}$
$I_{PMON(CAPA)}$	Power Monitor Output Current Capability	$V_{CC} \geq 12\text{V}$ , $V_{PMON} \geq 0\text{V}$ , and $V_V = -9\text{V}$ , $V_I = -225\text{mV}$ , or $V_V = 9\text{V}$ , $V_I = 225\text{mV}$	●	900		1200	$\mu\text{A}$
		$V_{CC} \geq 12\text{V}$ , $V_{PMON} \geq 0.5\text{V}$ , and $V_V = -9\text{V}$ , $V_I = 225\text{mV}$ , or $V_V = 9\text{V}$ , $V_I = -225\text{mV}$	●	-240		-1200	$\mu\text{A}$
		$V_{CC} \geq 12\text{V}$ , $V_{PMON} \geq 4\text{V}$ , and $V_V = -9\text{V}$ , $V_I = 225\text{mV}$ , or $V_V = 9\text{V}$ , $V_I = -225\text{mV}$	●	-800		-1200	$\mu\text{A}$

## ELECTRICAL CHARACTERISTICS

The ● denotes the specifications which apply over the full operating temperature range, otherwise specifications are at  $T_A = 25^\circ\text{C}$ . All specifications apply at  $6\text{V} \leq V_{\text{CC}} \leq 80\text{V}$ , unless otherwise specified.

SYMBOL	PARAMETER	CONDITIONS	MIN	TYP	MAX	UNITS	
$V_{\text{PMON}}$	Power Monitor Output Compliance Voltage	$V_{\text{CC}} \leq 12\text{V}$ , $I_{\text{PMON}} \geq 0\mu\text{A}$	●	0	$V_{\text{CC}} - 4.5$	V	
		$12\text{V} < V_{\text{CC}} < 30\text{V}$ , $I_{\text{PMON}} \geq 0\mu\text{A}$	●	0	7.5	V	
		$V_{\text{CC}} \geq 30\text{V}$ , $I_{\text{PMON}} \geq 0\mu\text{A}$	●	0	12	V	
		$V_{\text{CC}} \leq 12\text{V}$ , $I_{\text{PMON}} < 0\mu\text{A}$	●	0.5	$V_{\text{CC}} - 4.5$	V	
		$12\text{V} < V_{\text{CC}} < 30\text{V}$ , $I_{\text{PMON}} < 0\mu\text{A}$	●	0.5	7.5	V	
		$V_{\text{CC}} \geq 30\text{V}$ , $I_{\text{PMON}} < 0\mu\text{A}$	●	0.5	12	V	
$E_{\text{PMON}}$	Power Monitor Output Total Error (Note 4)	$ V_V \cdot V_I  \leq 0.4\text{V}^2$		±2	±5	%FS	
		$ V_V \cdot V_I  \leq 0.4\text{V}^2$ , $25^\circ\text{C} < T_A \leq 85^\circ\text{C}$		±2.5	±7	%FS	
		$ V_V \cdot V_I  \leq 0.4\text{V}^2$ , LT2940C	●	±2.5	±9	%FS	
		$ V_V \cdot V_I  \leq 0.4\text{V}^2$ , LT2940I	●	±3.5	±12	%FS	
		Quadrants I and III of Shaded Region in Figure 4	●	±5	±15	%FS	
$K_{\text{PMON}}$	Power Monitor Scaling Coefficient $I_{\text{PMON}} = K_{\text{PMON}} \cdot V_V \cdot V_I$	$ V_V \cdot V_I  = 0.4\text{V}^2$	●	485	500	515	$\mu\text{A}/\text{V}^2$
$V_{\text{V(OSP)}}$	Power Monitor Voltage Sense Input-Referred Offset Voltage	$V_V = 0\text{V}$	●	±40	±100	mV	
$V_{\text{I(OSP)}}$	Power Monitor Current Sense Input-Referred Offset Voltage	$V_I = 0\text{mV}$	●	±2	±6	mV	
$I_{\text{PMON(OS)}}$	Power Monitor Output Offset Current	$V_V = 0\text{V}$ , $V_I = 0\text{mV}$	●	±6	±15	$\mu\text{A}$	
$BW_{\text{PMON}}$	Power Monitor Output Bandwidth	$R_{\text{PMON}} = 2\text{k}$		0.5		MHz	

### Current Monitor (Note 2)

$I_{\text{IMON(FS)}}$	Current Monitor Output Current Operating Range		●	±200		$\mu\text{A}$	
$V_{\text{IMON}}$	Current Monitor Output Compliance Voltage	$V_{\text{CC}} \leq 12\text{V}$ , $I_{\text{IMON}} \geq 0\mu\text{A}$	●	0	$V_{\text{CC}} - 4.5$	V	
		$12\text{V} < V_{\text{CC}} < 30\text{V}$ , $I_{\text{IMON}} \geq 0\mu\text{A}$	●	0	7.5	V	
		$V_{\text{CC}} \geq 30\text{V}$ , $I_{\text{IMON}} \geq 0\mu\text{A}$	●	0	12	V	
		$V_{\text{CC}} \leq 12\text{V}$ , $I_{\text{IMON}} < 0\mu\text{A}$	●	0.5	$V_{\text{CC}} - 4.5$	V	
		$12\text{V} < V_{\text{CC}} < 30\text{V}$ , $I_{\text{IMON}} < 0\mu\text{A}$	●	0.5	7.5	V	
		$V_{\text{CC}} \geq 30\text{V}$ , $I_{\text{IMON}} < 0\mu\text{A}$	●	0.5	12	V	
$E_{\text{IMON}}$	Current Monitor Output Total Error (Note 4)	$ V_I  \leq 200\text{mV}$ , $25^\circ\text{C} \leq T_A \leq 85^\circ\text{C}$		±1.5	±3	%FS	
		$ V_I  \leq 200\text{mV}$ , LT2940C	●	±2	±3.5	%FS	
		$ V_I  \leq 200\text{mV}$ , LT2940I	●	±2	±4	%FS	
		$200\text{mV} <  V_I  \leq 225\text{mV}$	●	±2.5	±5	%FS	
$G_{\text{IMON}}$	Current Monitor Scaling, $I_{\text{IMON}} = G_{\text{IMON}} \cdot V_I$	$V_I = \pm 200\text{mV}$	●	975	1000	1025	$\mu\text{A}/\text{V}$
$V_{\text{I(OSI)}}$	Current Monitor Current Sense Input-Referred Offset Voltage		●	±2.5	±7	mV	
$BW_{\text{IMON}}$	Current Monitor Output Bandwidth	$R_{\text{IMON}} = 2\text{k}$		1		MHz	

### Comparator

$V_{\text{CMP(TH)}}$	Comparator Threshold Voltage	CMP+ Rising	●	1.222	1.240	1.258	V
$\Delta V_{\text{CMP(HYST)}}$	Comparator Threshold Hysteresis	CMP+ Falling	●	-15	-35	-60	mV
$I_{\text{CMP(BIAS)}}$	Comparator Input Bias Current	$1\text{V} \leq V_{\text{CMP+}} \leq 1.5\text{V}$	●	±100	±300		nA
$I_{\text{CMP(OUT)(OL)}}$	CMPOUT Output Low Voltage	CMP+ High, $I_{\text{CMPOUT}} = 3\text{mA}$	●	0.2	0.4		V

**ELECTRICAL CHARACTERISTICS** The ● denotes the specifications which apply over the full operating temperature range, otherwise specifications are at  $T_A = 25^\circ\text{C}$ . All specifications apply at  $6\text{V} \leq V_{CC} \leq 80\text{V}$ , unless otherwise specified.

SYMBOL	PARAMETER	CONDITIONS	MIN	TYP	MAX	UNITS	
$I_{\text{CMPOUT(LK)}}$	CMPOUT Leakage Current	CMP+ Low, $V_{CC} = 36\text{V}$ , $0.4\text{V} \leq V_{\text{CMPOUT}} \leq 36\text{V}$	●	±0.15	±1	μA	
$I_{\text{CMPOUT(OL)}}$	CMPOUT Output Low Voltage	CMP+ Low, $I_{\text{CMPOUT}} = 3\text{mA}$	●	0.2	0.4	V	
$I_{\text{CMPOUT(LK)}}$	CMPOUT Leakage Current	CMP+ High, $V_{CC} = 36\text{V}$ , $0.4\text{V} \leq V_{\text{CMPOUT}} \leq 36\text{V}$	●	±0.15	±1	μA	
$t_{\text{DLY}}$	Comparator Propagation Delay	Output Pulling Down	●	0.7	2	μs	
$V_{\text{LATCH(IL)}}$	LATCH Input Low Voltage		●	0.5	0.8	1.2	V
$V_{\text{LATCH(IO)}}$	LATCH Input Open Voltage		●	1.25	1.5	1.95	V
$V_{\text{LATCH(IH)}}$	LATCH Input High Voltage		●	2.0	2.2	2.5	V
$I_{\text{LATCH(LK)}}$	LATCH Input Allowable Leakage in Open State		●		±10	μA	
$I_{\text{LATCH(BIAS)}}$	LATCH Input Bias Current	$V_{\text{LATCH}} = 0\text{V}$	●	-11	-17	-23	μA
		$V_{\text{LATCH}} = 80\text{V}$	●	11	17	23	μA

**Note 1:** Stresses beyond those listed under Absolute Maximum Ratings may cause permanent damage to the device. Exposure to any Absolute Maximum Rating condition for extended periods may affect device reliability and lifetime.

**Note 2:** All currents into pins are positive, and all voltages are referenced to GND unless otherwise noted. Current sourced by the PMON pin or the IMON pin is defined as positive; current sunk as negative.

**Note 3:** The LT2940 may safely drive its own PMON and IMON output voltages above the absolute maximum ratings. Do not apply any external source that drives the voltage above absolute maximum.

**Note 4:** Full-scale equals ±200μA.

**Note 5:**  $V^+$  and  $V^-$  pin voltages must each fall within the voltage sense pin operating range specification.

**Note 6:**  $I^+$  and  $I^-$  pin voltages must each fall within the current sense pin operating range specification.

**TYPICAL PERFORMANCE CHARACTERISTICS**

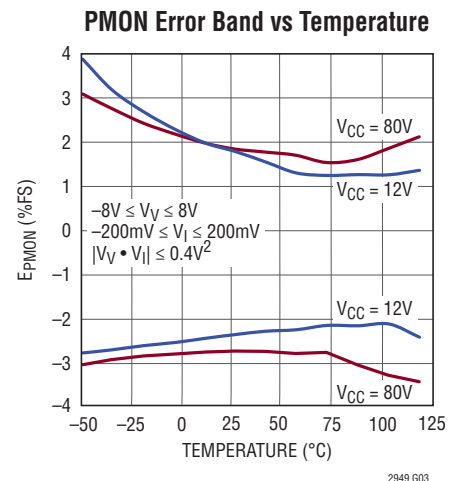
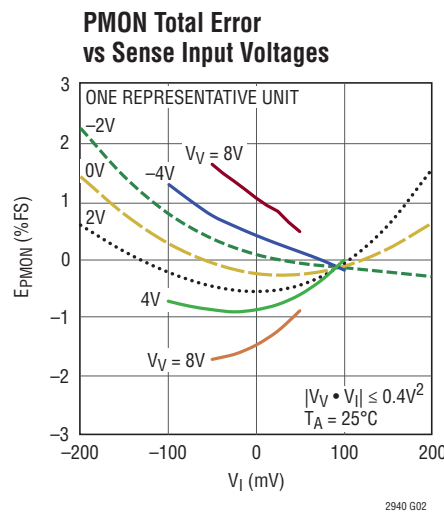
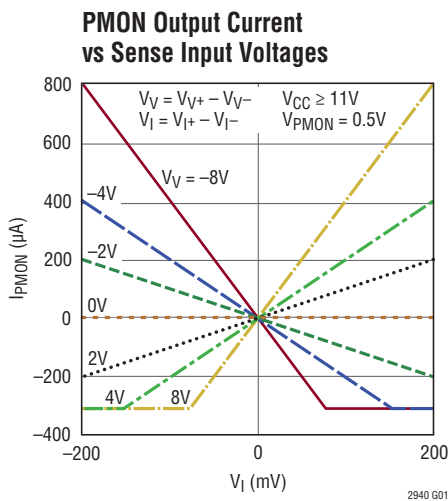

TYPICAL PERFORMANCE CHARACTERISTICS

PMON Current vs Power Sense Product

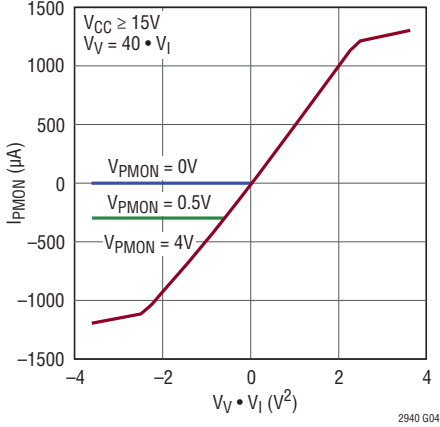

PMON and IMON Voltage Compliance

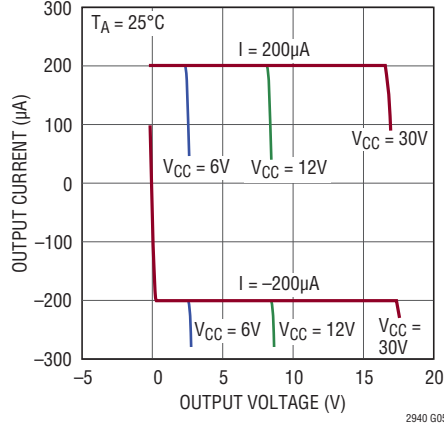

Supply Current vs Supply Voltage

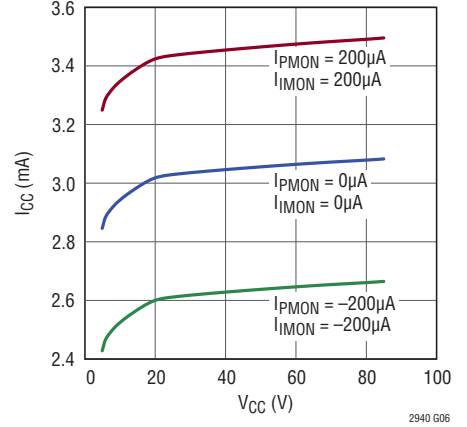

IMON Current vs Current Sense Voltage

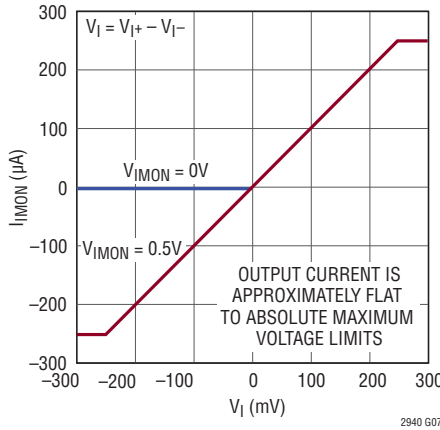

IMON Total Error vs Current Sense Voltage

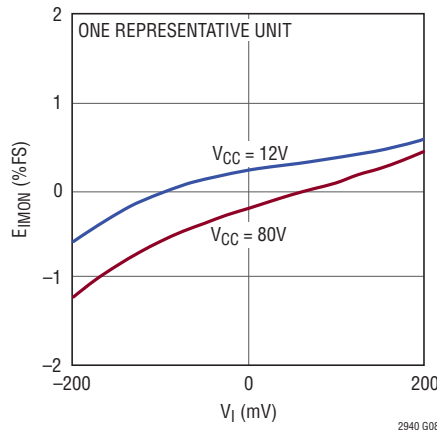

IMON Error Band vs Temperature

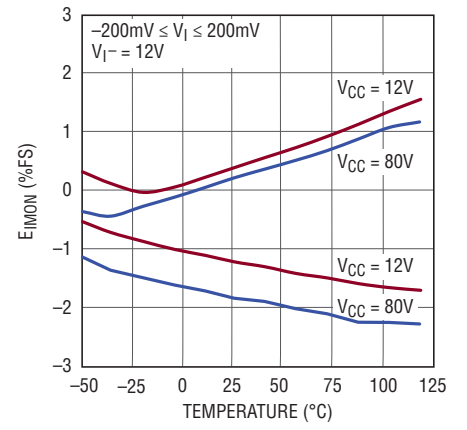

PMON Step Response

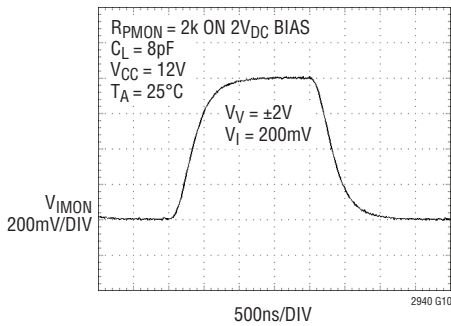

PMON Step Response

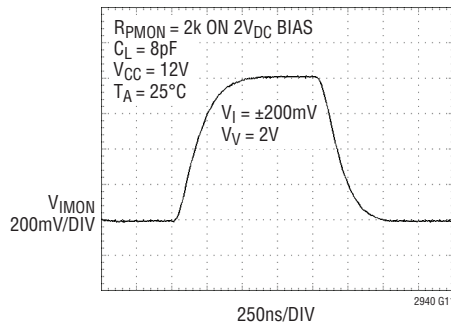

IMON Step Response

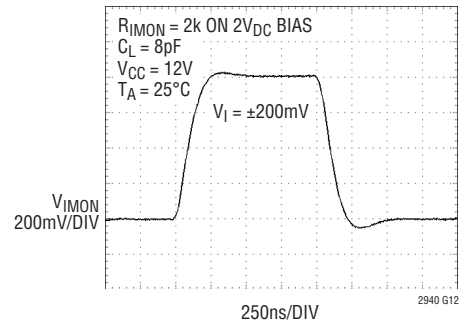

# TYPICAL PERFORMANCE CHARACTERISTICS

**Power Supply Rejection Ratio vs Frequency**

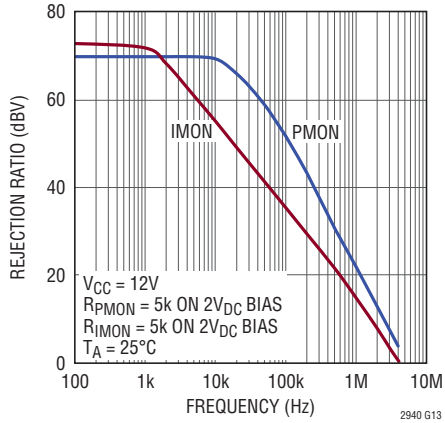

**PMON Input Feedthrough vs Frequency**

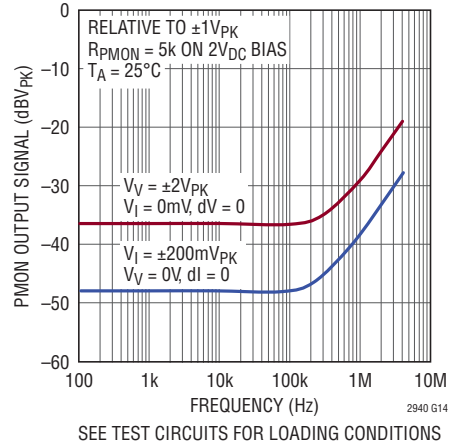

**PMON Frequency Response to Voltage Sense**

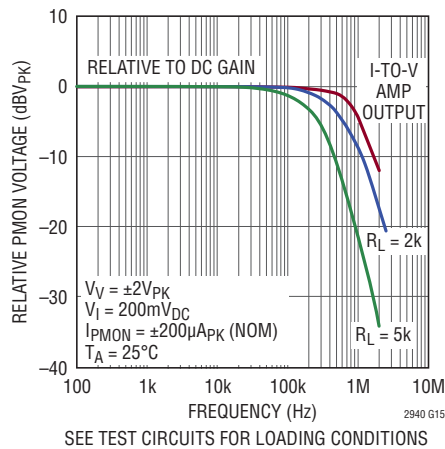

**PMON Frequency Response to Current Sense**

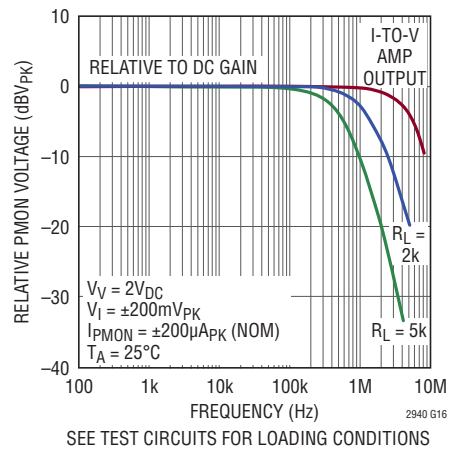

**IMON Frequency Response to Current Sense**

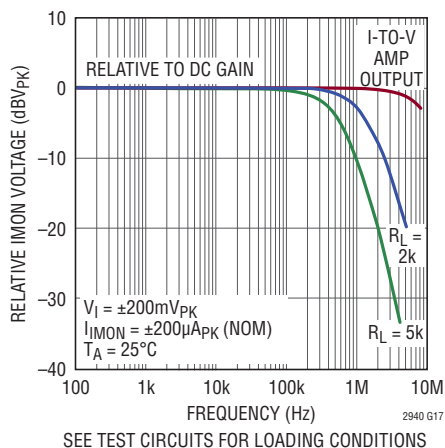

**Open Collector Current vs Open Collector Voltage**

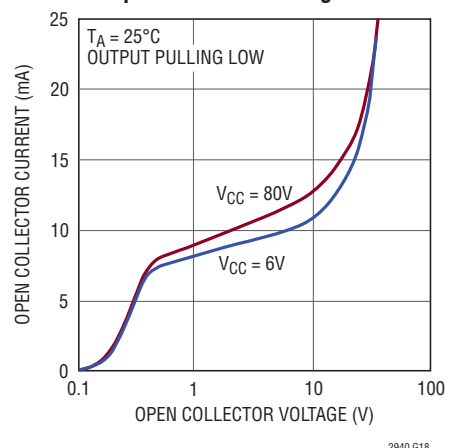

## PIN FUNCTIONS

**$\overline{\text{CMPOUT}}$  (Pin 1):** Inverting Open-Collector Comparator Output. When the LATCH pin's state does not override the comparator,  $\overline{\text{CMPOUT}}$  pulls low when  $\text{CMP}^+ > 1.24\text{V}$ . The pull-down shuts off when  $\text{CMP}^+ < 1.21\text{V}$ , or  $V_{\text{CC}} < 2.5\text{V}$  or when the LATCH pin is low.  $\overline{\text{CMPOUT}}$  may be pulled up to 36V maximum. Do not sink more than 22mA DC.

**CMPOUT (Pin 2):** Noninverting Open-Collector Comparator Output. When the LATCH pin's state does not override the comparator, CMPOUT pulls low when  $\text{CMP}^+ < 1.21\text{V}$ , or  $V_{\text{CC}} < 2.5\text{V}$ , or when the LATCH pin is low. The pull-down shuts off when  $\text{CMP}^+ > 1.24\text{V}$ . CMPOUT may be pulled up to 36V maximum. Do not sink more than 22mA DC.

**$\text{CMP}^+$  (Pin 3):** Positive Comparator Input. The integrated comparator resolves to high when the pin voltage exceeds the 1.24V internal reference. The comparator input has 35mV of negative hysteresis, which makes its falling trip point approximately 1.21V. Do not exceed 36V. Tie  $\text{CMP}^+$  to GND if unused.

**PMON (Pin 4):** Proportional-to-Power Monitor Output. This push-pull output sources or sinks a current proportional to the product of the voltage sense and current sense inputs. A resistor from PMON to GND creates a positive voltage when the power product is positive. The full-scale output of  $\pm 200\mu\text{A}$  is generated for a sense input product of  $\pm 0.4\text{V}^2$ . Do not exceed  $V_{\text{CC}} + 1\text{V}$ , up to 16V maximum. Tie PMON to GND if unused.

**IMON (Pin 5):** Proportional-to-Current Monitor Output. This push-pull output sources or sinks a current proportional to the voltage at the current sense input, which is typically generated by a sense resistor that measures a current. A resistor from IMON to GND creates a positive voltage when the sensed current is positive. The full-scale output of  $\pm 200\mu\text{A}$  is generated by a current sense input of  $\pm 200\text{mV}$ . Do not exceed  $V_{\text{CC}} + 1\text{V}$ , up to 16V maximum. Tie IMON to GND if unused.

**GND (Pin 6):** Device Ground.

**$V^+$ ,  $V^-$  (Pins 8, 7):** Voltage Sense Inputs. The voltage difference between these pins is the voltage input factor to the power calculation multiplier. The difference may be positive or negative, but both pin voltages must be at or above  $\text{GND} - 100\text{mV}$ . The input differential voltage range is  $\pm 8\text{V}$ . Do not exceed 36V on either pin.

**LATCH (Pin 9):** Comparator Mode Input. Conditions at this three-state input pin control the comparator's behavior. When LATCH is open, the comparator's outputs track its input conditions (with hysteresis). When LATCH is held above 2.5V, the comparator's outputs latch when  $\text{CMP}^+$  exceeds 1.24V (CMPOUT open,  $\overline{\text{CMPOUT}}$  pull-down). While  $\text{LATCH} \leq 0.5\text{V}$  or  $V_{\text{CC}} < 2.5\text{V}$ , the comparator's outputs clear (CMPOUT pull-down,  $\overline{\text{CMPOUT}}$  open) regardless of the  $\text{CMP}^+$  pin voltage. The LATCH pin high impedance input state tolerates  $\pm 10\mu\text{A}$  of leakage current. Bypass this pin to GND to compensate for high  $dV/dt$  on adjacent pins. Do not exceed 100V on this pin.

**$I^+$ ,  $I^-$  (Pins 11, 10):** Current Sense Inputs. The voltage difference at these pins represents the current input factor to the power calculation multiplier and to the current scaler. The difference may be positive or negative, but both pin voltages must be at least 4V and no more than 80V above GND, completely independent of the  $V_{\text{CC}}$  voltage. Both pins sink approximately  $100\mu\text{A}$  of bias current in addition to having an effective  $5\text{k}\Omega$  shunt between them. The input differential voltage range is  $\pm 200\text{mV}$ . Do not exceed  $\pm 36\text{V}$  differentially or 100V on either pin.

**$V_{\text{CC}}$  (Pin 12):** Voltage Supply. The voltage supply operating range is 6V to 80V. When operating with  $V_{\text{CC}} > 15\text{V}$ , package heating can be reduced by adding an external series dropping resistor. Bypass this pin to GND to improve supply rejection at frequencies above 10kHz as needed. Do not exceed 100V on this pin.

**Exposed Pad (Pin 13 in DFN Package):** The exposed pad may be left open or connected to device ground. For best thermal performance, the exposed pad must be soldered to the PCB.

# FUNCTIONAL BLOCK DIAGRAM

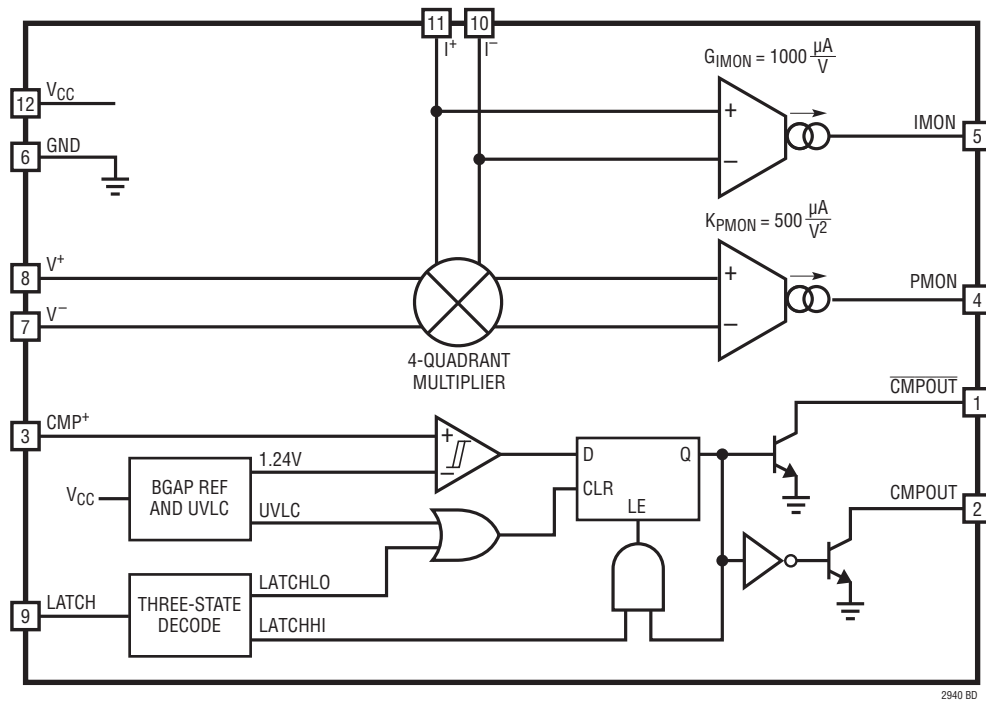

# TEST CIRCUITS

Resistor on DC Bias

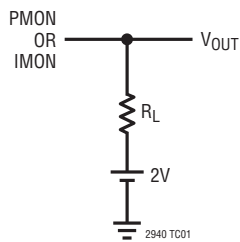

I-to-V Amplifier

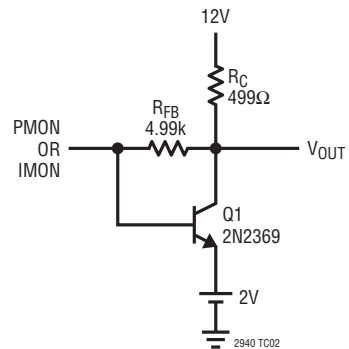

## APPLICATIONS INFORMATION

### Introduction

The LT2940 power and current monitor brings together circuits necessary to measure, monitor and control power. In circuits where voltage is constant, power is directly proportional to current. The LT2940 enables power monitoring and control in applications where both the current and the voltage may be variable due to supply voltage uncertainty, component parametric changes, transient conditions, time-varying signals, and so forth.

The LT2940's four-quadrant multiplier calculates instantaneous power from its voltage sense and current sense inputs. Its output driver sources and sinks current proportional to power (magnitude and direction), which affords flexible voltage scaling, simple filtering and, into a reference, bipolar signals. Its onboard comparator is the final piece required for integrated power monitoring. In addition, the LT2940 provides a proportional-to-current output that allows for equally straightforward scaling, filtering and monitoring of the sensed current.

Please note: although standard convention defines currents as positive going into a pin (as is generally the case in the Electrical Characteristics table), the opposite is true of the PMON and IMON pins. Throughout this data sheet the power and current monitor output currents are defined positive coming out of PMON and IMON, respectively. Adopting this convention lets positive voltage differences at the current and voltage sense pins yield positive currents sourced from PMON and IMON that can be scaled to positive ground referenced voltages with a resistor.

### Multiplier Operation

The LT2940 power and current monitor contains a four-quadrant multiplier designed to measure the voltage and current of a generator or load, and output signals proportional to power and current. Figure 1 shows a signal path block diagram. The operating ranges of the voltage sense and current sense inputs are included. To simplify the notation, the differential input voltages are defined as:

$$V_V = V_{V+} - V_{V-} \quad (1a)$$

$$V_I = V_{I+} - V_{I-} \quad (1b)$$

The full scale output of the multiplier core is  $\pm 0.4V^2$ , which the PMON output driver converts to current through a scale factor of  $K_{PMON}$ .

$$I_{PMON} = K_{PMON} \cdot V_V \cdot V_I \quad (2)$$

$$K_{PMON} = 500 \frac{\mu A}{V^2} \quad (3)$$

The voltage across the current sense input pins is converted to a current by the IMON output driver through the scale factor of  $G_{IMON}$ .

$$I_{IMON} = G_{IMON} \cdot V_I \quad (4)$$

$$G_{IMON} = 1000 \frac{\mu A}{V} \quad (5)$$

Both the PMON and IMON outputs reach full-scale at  $\pm 200\mu A$ .

The headroom and compliance limits for the input and output pins are summarized in Table 1 for easy reference. It is important to note that the current sense inputs,  $I^+$  and  $I^-$ , operate over a 4V to 80V range completely independent of the LT2940's supply pin,  $V_{CC}$ . Note also that the inputs accept signals of either polarity, and that the

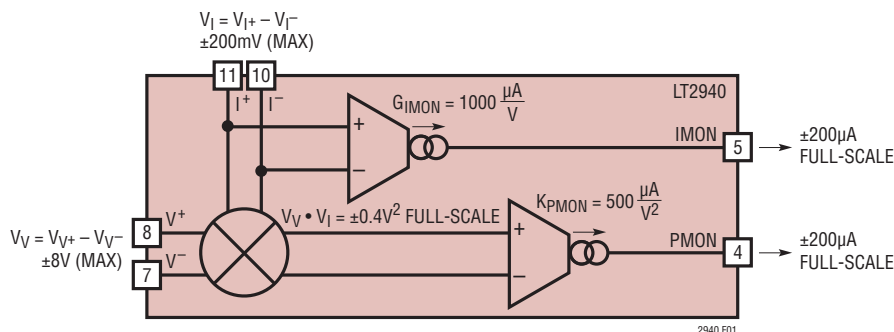

Figure 1. LT2940 Signal Path Diagram

## APPLICATIONS INFORMATION

**Table 1. LT2940 Essential Operating Parameters to Achieve Specified Accuracy ( $V_{CC}$  Operating Range = 6V to 80V)**

PARAMETER	SENSE INPUT PINS	PIN VOLTAGE LIMIT	INPUT OPERATING RANGE	SCALING TO OUTPUT	MONITOR OUTPUT PINS	OUTPUT OPERATING RANGE	OUTPUT VOLTAGE COMPLIANCE
Voltage	$V^+$ , $V^-$	0V to $V_{CC} - 3V$ at $V_{CC} \leq 12V$ 0V TO 9V at $12V < V_{CC} < 30V$ 0V to 18V at $V_{CC} \geq 30V$	$V_V = \pm 8V$	-	-	-	-
Current	$I^+$ , $I^-$	4V to 80V*	$V_I = \pm 200mV$	$G_{IMON} = 1000\mu A/V$	IMON	$I_{IMON} = \pm 200\mu A$	Sourcing: 0V to $V_{CC} - 4.5V$ at $V_{CC} \leq 7.5V$ 0V to 7.5V at $12V < V_{CC} < 30V$ 0V to 12V at $V_{CC} \geq 30V$
Power	$V^+$ , $V^-$ , $I^+$ , $I^-$	See Above Limits	$V_V \cdot V_I = \pm 0.4V^2$	$K_{PMON} = 500\mu A/V^2$	PMON	$I_{PMON} = \pm 200\mu A$	Sinking: As Above, Except Minimum is 0.5V

\* The current sense range is completely independent of the supply voltage.

PMON and IMON outputs are capable of indicating forward and reverse flow of power and current, provided they are advantageously biased.

The multiplier core full-scale product of  $\pm 0.4V^2$  may be reached over a range of voltage and current inputs, as shown in Figure 2. For example, voltage sense and current sense combinations of 8V and 50mV, 4V and 100mV, and 2V and 200mV each multiply to  $0.4V^2$ , and thus produce 200 $\mu A$  at PMON. This arrangement allows the core to operate at full-scale, and therefore at best accuracy, over a 4:1 range of current and voltage, a readily appreciated feature when monitoring power in variable supply applications.

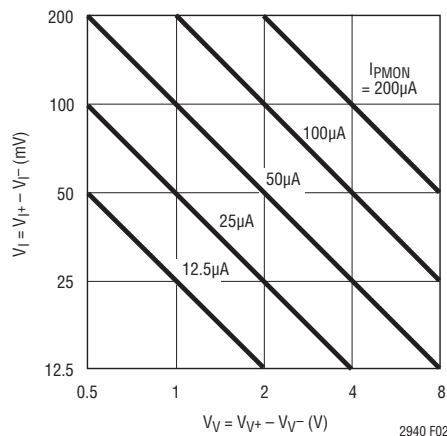

**Figure 2. PMON Output Current as a Function of Sense Input Voltages**

### Essential Design Equations

A few equations are needed to calculate input scaling factors and achieve a desired output. Consider the basic application in Figure 3, where the power  $P_{IN}$  is to be measured as the product of voltage  $V_{IN}$  and current  $I_{IN}$ :

$$P_{IN} = V_{IN} \cdot I_{IN} \quad (6)$$

The actual measured quantities  $V_{IN}$  and  $I_{IN}$  are scaled to be level-compatible with the LT2940. In this basic application, a simple resistive voltage divider scales  $V_{IN}$ , and a sense resistor scales  $I_{IN}$ .

$$V_V = V_{IN} \cdot k_V \quad (7a)$$

$$k_V = \frac{R1}{R1 + R2} \quad (7b)$$

$$V_I = I_{IN} \cdot k_I \quad (8a)$$

$$k_I = R_{SENSE} \quad (8b)$$

The PMON output current is given by:

$$I_{PMON} = K_{PMON} \cdot V_{IN} \cdot k_V \cdot I_{IN} \cdot k_I \quad (9a)$$

or

$$I_{PMON} = P_{IN} \cdot K_{PMON} \cdot k_V \cdot k_I \quad (9b)$$

The output current may be positive (sourcing) or negative (sinking) depending on the signs of  $V_{IN}$ ,  $k_V$ ,  $I_{IN}$ , and  $k_I$ . Provided that the magnitudes of  $V_V$  and  $V_I$  do not exceed 8V and 200mV as shown in Figure 2, at

APPLICATIONS INFORMATION

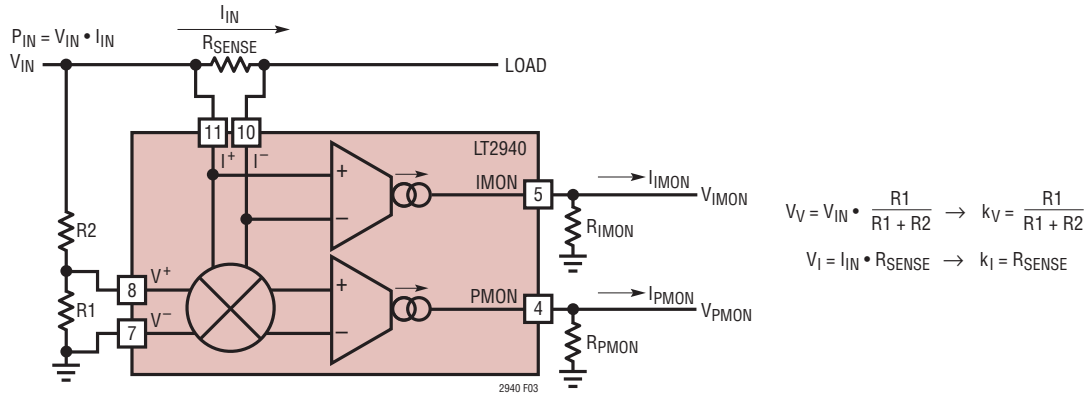

Figure 3. Basic Power Sensing Application Showing Derivation of  $k_V$  and  $k_I$

the full-scale output current of  $\pm 200\mu\text{A}$ , the achievable full-scale power is:

$$P_{IN(FS)} = \frac{0.4V^2}{k_V \cdot k_I} \quad (10)$$

In some applications the PMON output is converted to a voltage by a load resistor:

$$V_{PMON} = I_{PMON} \cdot R_{PMON} \quad (11)$$

The complete end-to-end scaling is then given by:

$$V_{PMON} = P_{IN} \cdot K_{PMON} \cdot k_V \cdot k_I \cdot R_{PMON} \quad (12)$$

The current monitor output current at IMON is found by combining Equations 4 and 8a:

$$I_{IMON} = I_{IN} \cdot G_{IMON} \cdot k_I \quad (13)$$

The output current may be positive (sourcing) or negative (sinking) depending on the signs of  $I_{IN}$  and  $k_I$ . Provided that the magnitude of  $V_I$  does not exceed 200mV, at the full-scale output current of  $\pm 200\mu\text{A}$  the achievable full-scale input current is:

$$I_{IN(FS)} = \frac{0.2V}{k_I} \quad (14)$$

If IMON current is converted to a voltage by a load resistor, then:

$$V_{IMON} = I_{IMON} \cdot R_{IMON} \quad (15)$$

and the final end-to-end scaling is given by:

$$V_{IMON} = I_{IN} \cdot G_{IMON} \cdot k_I \cdot R_{IMON} \quad (16)$$

Accuracy

The principal accuracies of the power and current monitor outputs are characterized as absolute percentages of full-scale output currents, using the nominal values of scaling parameters. The total error of the  $I_{PMON}$  output,  $E_{PMON}$ , is typically  $\pm 2\%$ , and is defined as:

$$E_{PMON} = \frac{I_{PMON} - 500 \frac{\mu\text{A}}{\sqrt{2}} \cdot (V_V \cdot V_I)}{200\mu\text{A}} \cdot 100\% \quad (17)$$

Contributors to the power output accuracy such as the scaling ( $K_{PMON}$ ), the output offset ( $I_{PMON(OS)}$ ), and the voltage and current sense input offsets ( $V_{V(OSP)}$  and  $V_{I(OSP)}$ ), are separately specified at key conditions and may be totaled using the root sum-of-squares (RSS) method.

The total error of the  $I_{IMON}$  output,  $E_{IMON}$ , is typically  $\pm 1.5\%$ , and is defined as:

$$E_{IMON} = \frac{I_{IMON} - 1000 \frac{\mu\text{A}}{V} \cdot V_I}{200\mu\text{A}} \cdot 100\% \quad (18)$$

Contributors to the current output accuracy such as the scaling ( $G_{IMON}$ ) and the current sense input offset ( $V_{I(OSI)}$ ) are separately specified at key conditions. Here again, use the RSS method of totaling errors.

## APPLICATIONS INFORMATION

### Multiplier Operating Regions

The operating regions of the four-quadrant multiplier are illustrated in Figure 4. Note that while Figure 2's axes employed logarithmic (octave) scales to allow constant-power trajectories to be straight lines, Figure 4's axes are linear to better accommodate negative inputs. Constant-power trajectories are thus arcs.

The heavy line circumscribing the guaranteed accuracy region is limited both by the product of the sense inputs (the curved edges) and by each sense input's differential range (the straight edges). The maximum product that realizes the specified accuracy is  $V_V \cdot V_I = \pm 0.4V^2$ , and it produces nominally full-scale output currents of  $I_{PMON} = \pm 200\mu A$ . At the same time, the voltage and current sense inputs must not exceed  $\pm 8V$  and  $\pm 200mV$ , respectively. In the shaded functional region, multiplying occurs but the output current accuracy is derated as specified in the Electrical Characteristics section.

The shaded functional region offers headroom beyond the guaranteed range in all quadrants, and excellent sourcing current operation beyond the standard  $+0.4V^2$  sense product limit in quadrants I and III. In quadrants II and IV, the PMON current is limited by compliance range, so accuracy is not specified. See the Electrical Characteristics and Typical Performance Characteristics sections for operation in

these regions. Inputs beyond those ranges, and out to the absolute maximum ratings, are clipped internally.

### Range and Accuracy Considerations

The LT2940's performance and operating range may best be exploited by letting the broad application category steer design direction.

Constant-power applications comprise power level alarm circuits, whether tripping a circuit breaker, activating auxiliary circuits, or simply raising an alarm, and single-level power servo loops. In such applications, accuracy is best when the full-scale output current of the LT2940 represents the power level of interest, i.e., the  $I_{PMON} = 200\mu A$  load line (A) on Figure 5. Spans of voltage or current up to 4:1 naturally fit into the operating range of the LT2940.

Special constant-power applications are the same types of circuits (level measuring, servos) with additional restrictions. If operating within the guaranteed accuracy region of Figure 4 is important over voltage or current spans wider than 4:1, let a PMON current less than full-scale represent the power level. For example, the load line (B) of  $I_{PMON} = 50\mu A$  in Figure 5 covers a span of 16:1 ( $V_V = 8V$  to  $0.5V$  and  $V_I = 200mV$  to  $12.5mV$ ). Note that operating along line (C),  $I_{PMON} = 25\mu A$  allows a span of 32:1, but the channel offsets reduce the value of doing so. Operating

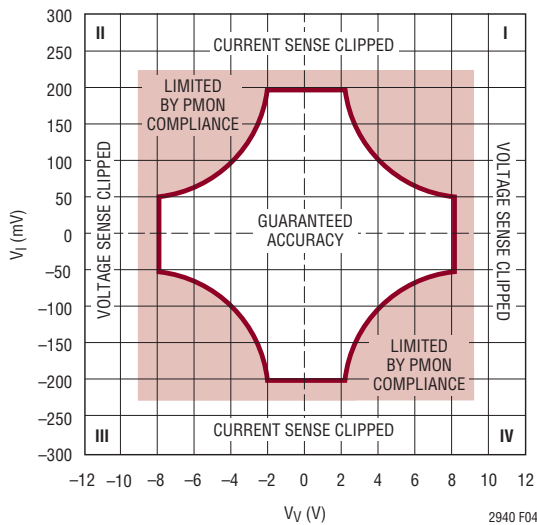

Figure 4. Multiplier Operating Regions vs Sense Input Voltages. Accuracy Is Derated in Shaded Areas

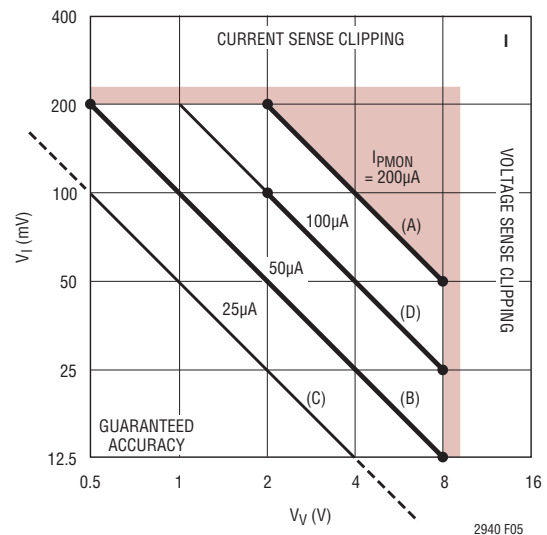

Figure 5. Various Constant-Power Curves in Quadrant I

## APPLICATIONS INFORMATION

below full-scale also affords scaling flexibility. Line (D) along  $I_{PMON} = 100\mu\text{A}$  covers a 4:1 range like (A), but the maximum  $V_I$  is 100mV, which reduces voltage drop and dissipation in the sense resistor.

Variable power applications comprise power measuring, whether battery charging, energy metering or motor monitoring, variable load-boxes, and other circuits where the significant metric is not a single value, and voltage and current may be independent of each other. Design in this case requires mapping the LT2940's sense ranges to cover the maximum voltage and the maximum current, while considering whether the power represented is at, above, or below full-scale  $I_{PMON}$ . For example, setting it at full-scale puts all values in the accurate range, setting it above puts more accuracy in nominal power levels and less accuracy in perhaps rarely encountered high levels, and setting below might afford flexibility to lower dissipation in the current sense resistor.

### Output Filtering and Integration

Lowpass filtering the output power or current signal is as simple as adding a capacitor in parallel with the output voltage scaling resistor at PMON or IMON. For example, adding 1nF in parallel with the PMON load resistor on the front page application creates a lowpass corner frequency of approximately 6.4kHz on the power monitor voltage.

Loaded by only a capacitor, the PMON pin voltage is proportional to the time-integral of power, which is energy. The integrating watt-hour meter application shown on the back page takes advantage of this convenience. In a

similar way, a capacitor load on IMON produces a voltage proportional to charge that can be used to create a coulomb counter.

### Comparator Function

The LT2940's integrated comparator features an internal fixed reference, complementary open-collector outputs and configurable latching. A rising voltage at the  $\text{CMP}^+$  pin is compared to the internal 1.24V threshold. 35mV (typical) negative hysteresis provides glitch protection and makes falling inputs trip the comparator at about 1.21V. The comparator result drives the open-collector  $\overline{\text{CMPOUT}}$  and  $\text{CMPOUT}$  pins which, when pulling down, sink at least 3mA down to 0.4V. See the Typical Performance Characteristics for more information. Complementary comparator outputs save external components in some applications. The  $\overline{\text{CMPOUT}}$  and  $\text{CMPOUT}$  pins may be pulled up externally to 36V maximum.

### Comparator Latching

The LATCH pin controls the behavior of the comparator outputs. When the LATCH pin is open, the comparator output latch is transparent. Leakage currents up to  $\pm 10\mu\text{A}$  will not change the decoded state of the LATCH pin. Internal circuits weakly drive the pin to about 1.5V. Adding a 10nF capacitor between LATCH and GND protects against high dV/dt on adjacent pins and traces. Where more than 30V and long inductive leads will be connected to LATCH, damp potentially damaging ringing with a circuit like that shown in Figure 6.

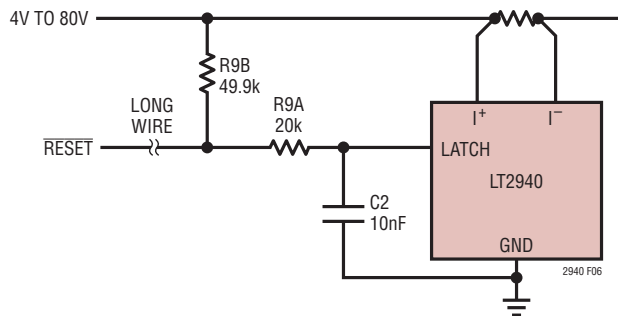

Figure 6. LATCH Pin Protective Damping

## APPLICATIONS INFORMATION

When the LATCH pin voltage exceeds 2.5V, the next high result from the comparator also enables the comparator latch. The CMPOUT pin goes open (high), and the  $\overline{\text{CMPOUT}}$  pin sinks current (low) regardless of the changes to the CMP+ level until the latch is cleared. Latch activation is level sensitive, not edge sensitive, so if  $\text{CMP}^+ > 1.24\text{V}$  when LATCH is brought above 2.5V, the comparator result is high, and the latch is set immediately. The LATCH pin voltage may be taken safely to 80V regardless of the  $V_{\text{CC}}$  pin voltage.

The latch is released and the comparator reports a low when  $\text{LATCH} \leq 0.5\text{V}$  or when  $V_{\text{CC}} < 2.3\text{V}$  regardless of the  $\text{CMP}^+$  pin voltage. In this state, the CMPOUT pin sinks current (low), while the  $\overline{\text{CMPOUT}}$  pin goes open (high). As with latching, clearing is level-sensitive: comparator outputs react to the input signal as soon as  $\text{LATCH} \geq 1.25\text{V}$  and  $V_{\text{CC}} > 2.7\text{V}$ .

### Thermal Considerations

If operating at high supply voltages, do not ignore package dissipation. At 80V the dissipation could reach 400mW; more if IMON or PMON current exceeds full-scale. Package thermal resistance is shown in the Pin Configuration section. Package dissipation can be reduced by simply adding a dropping resistor in series with the  $V_{\text{CC}}$  pin, as shown in Figure 7. The operating range of the current sense input pins  $I^+$  and  $I^-$ , which extends to 80V independent of  $V_{\text{CC}}$ , make this possible. The voltage ranges of the  $V^+$ ,  $V^-$ , PMON and IMON pins are, however, limited by  $V_{\text{CC}}$ . Consult Table 1 during design. Operating an open-collector output pin with simultaneously large current and large voltage bias also contributes to package heating and must be avoided.

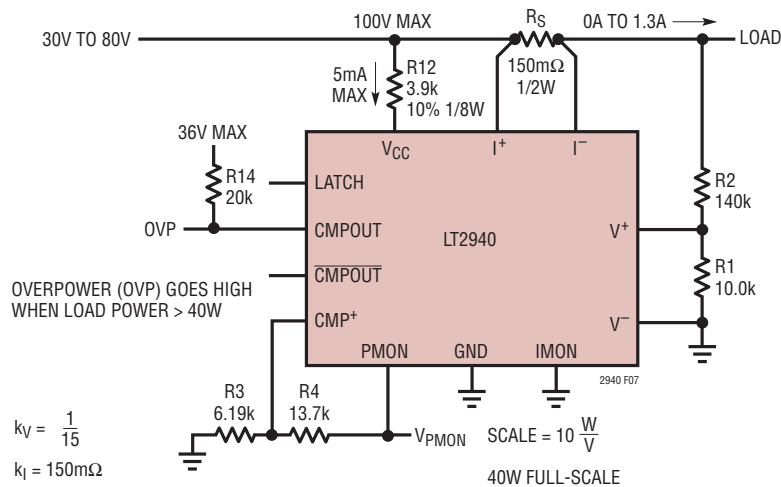
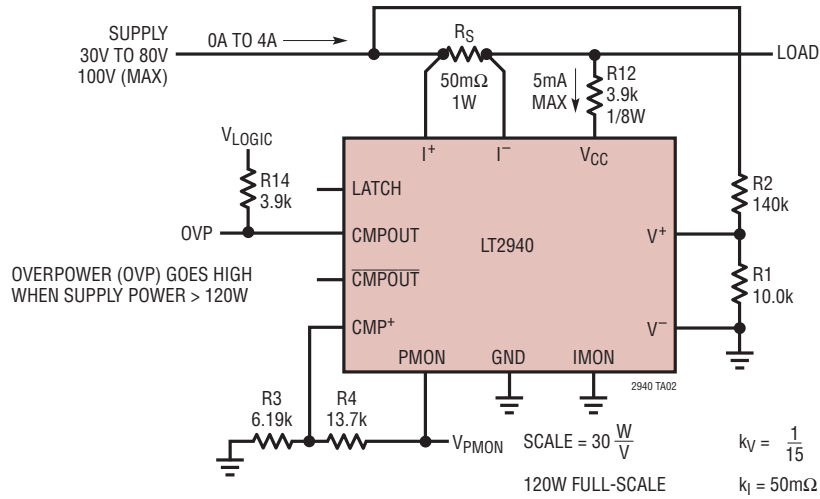

Figure 7. Supply Resistor Reduces Package Heating by Reducing  $V_{\text{CC}}$  Voltage

## TYPICAL APPLICATIONS

### 120W Supply Monitor Includes I<sub>CC</sub> of LT2940



### 12.5W PWM Heat Source

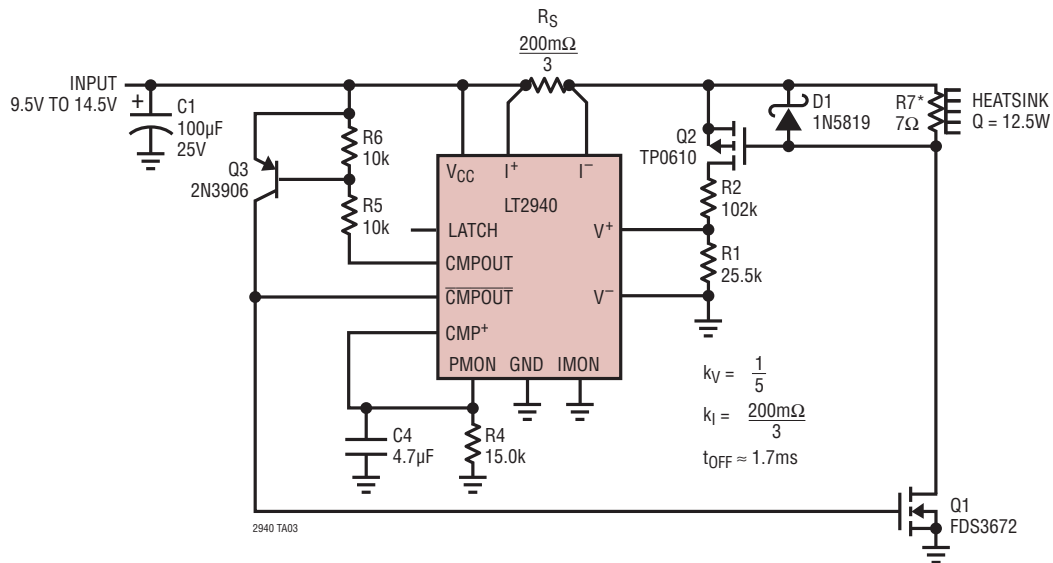

\* SEVEN 50Ω, 5W RESISTORS IN PARALLEL.  
 MULTIPLE UNITS FACILITATE SPREADING HEAT.

TYPICAL APPLICATIONS

30W Linear Heat Source

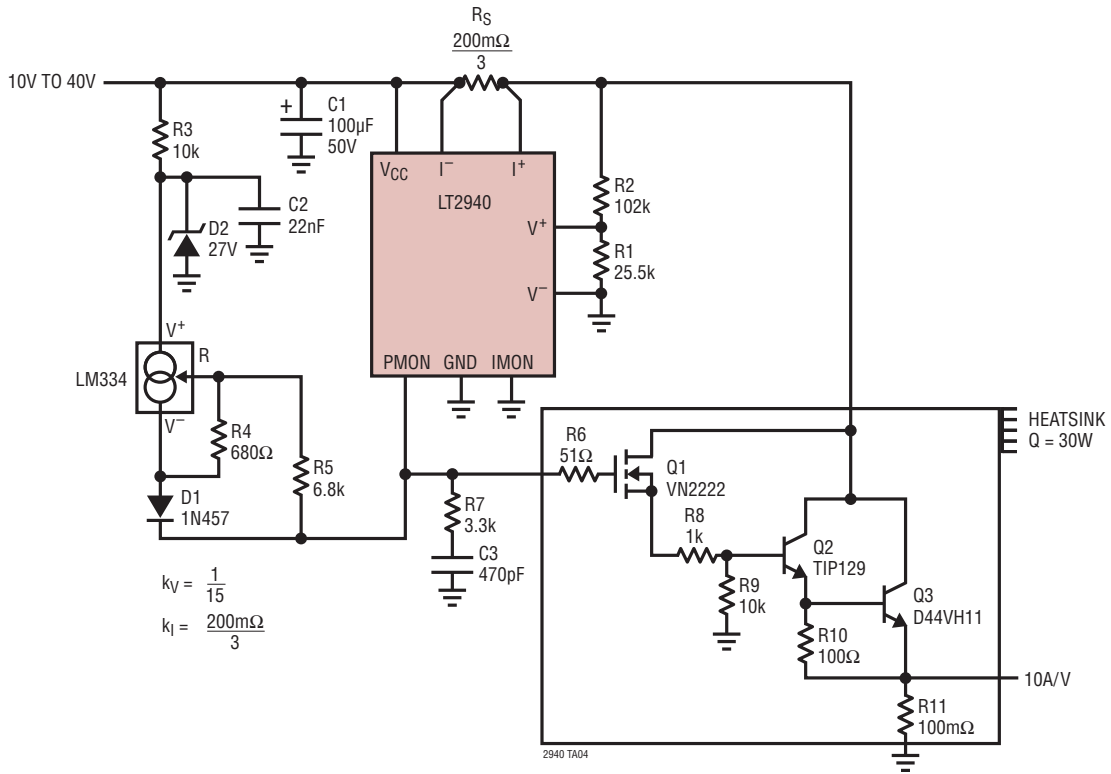

Wide Input Range 10W PWM Heat Source

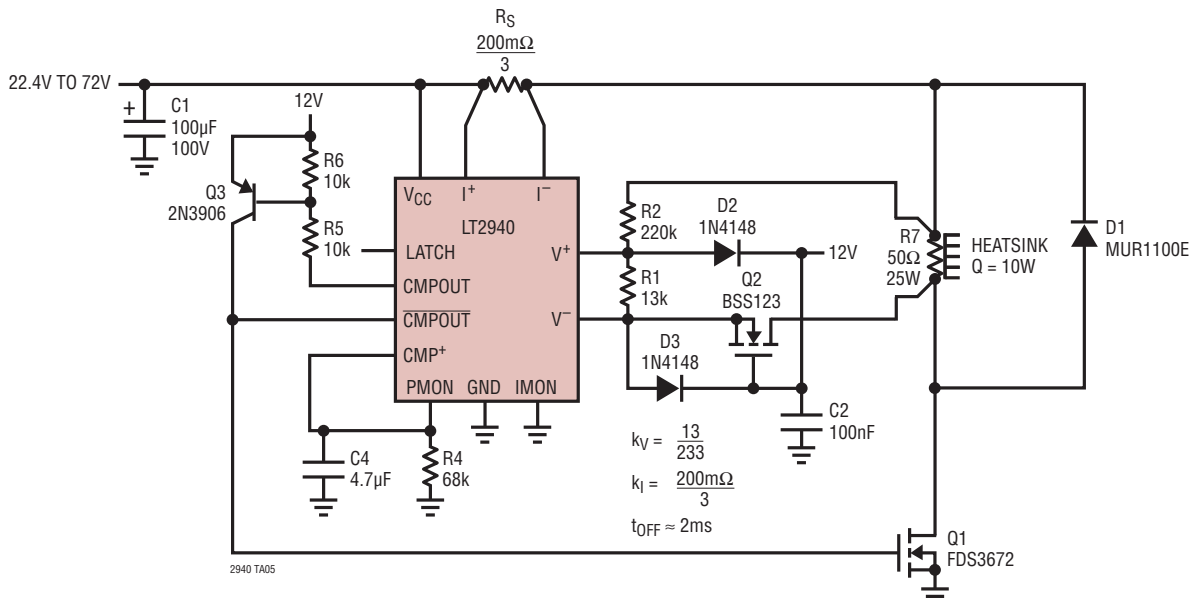

## TYPICAL APPLICATIONS

### 8V to 32V, 8W Load

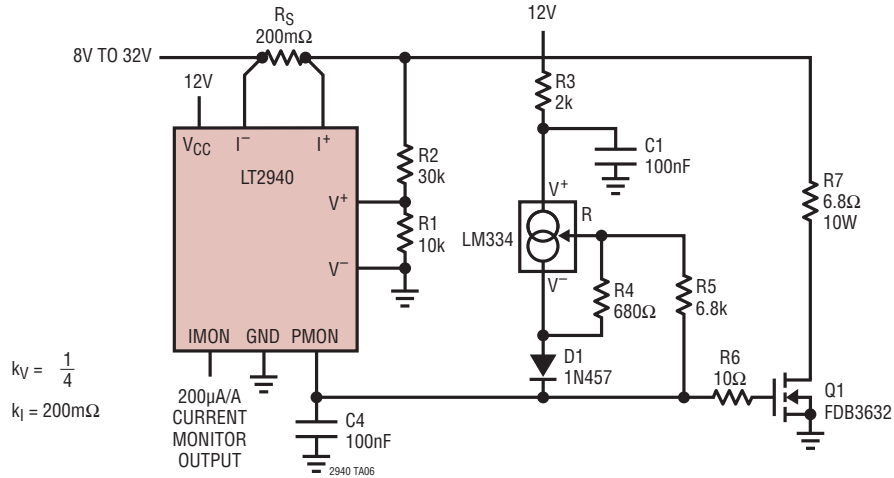

### Adjustable 0W to 10W Load Box with UVLO and Thermal Shutdown

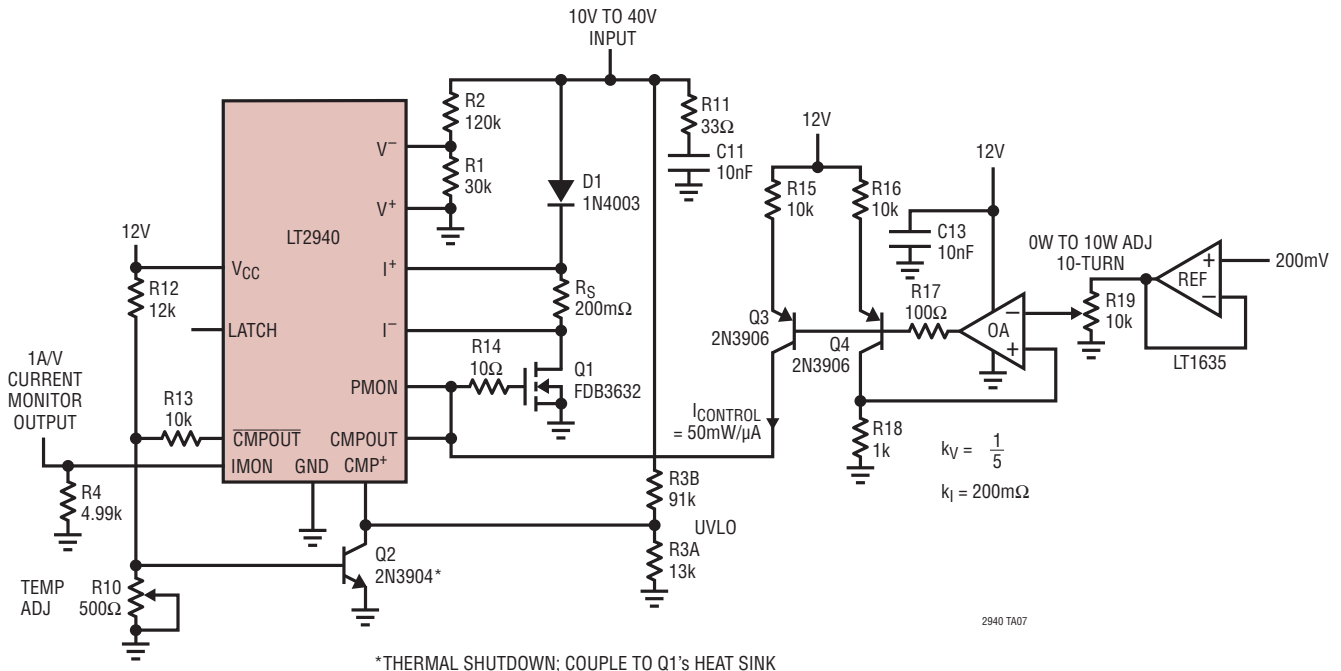



## TYPICAL APPLICATIONS

### 28V Power to Frequency Converter

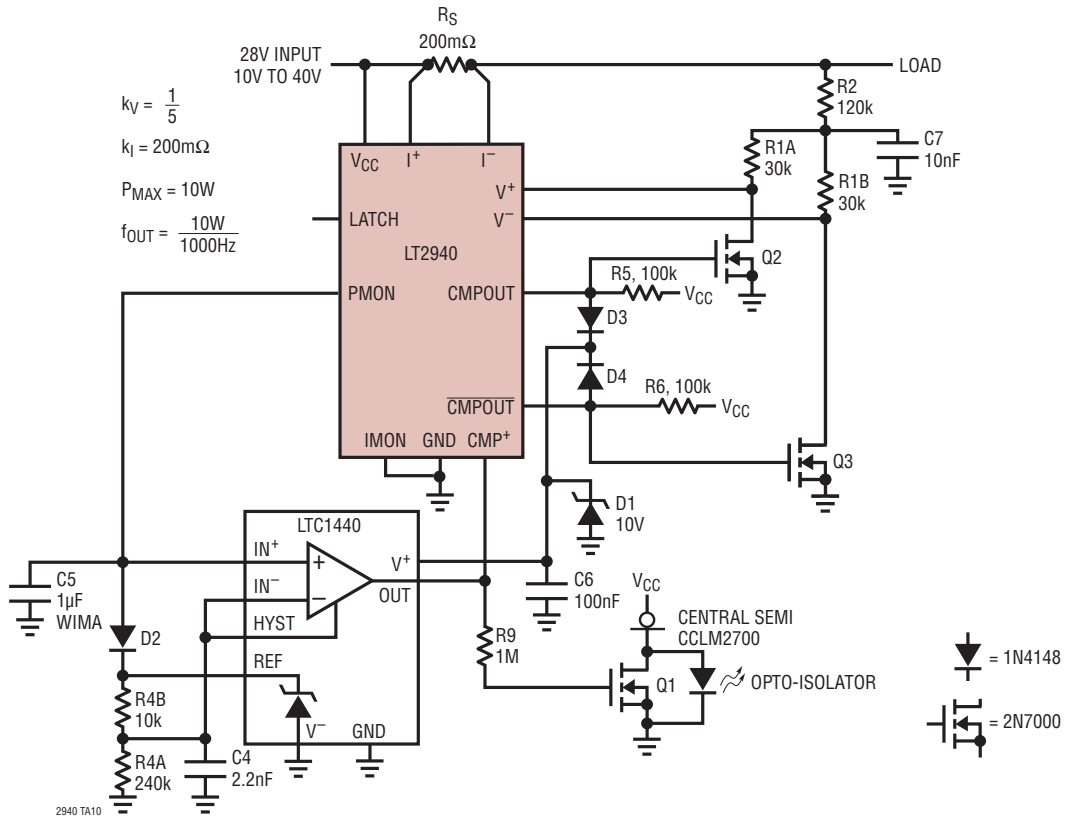

### Secondary-Side AC Circuit Breaker

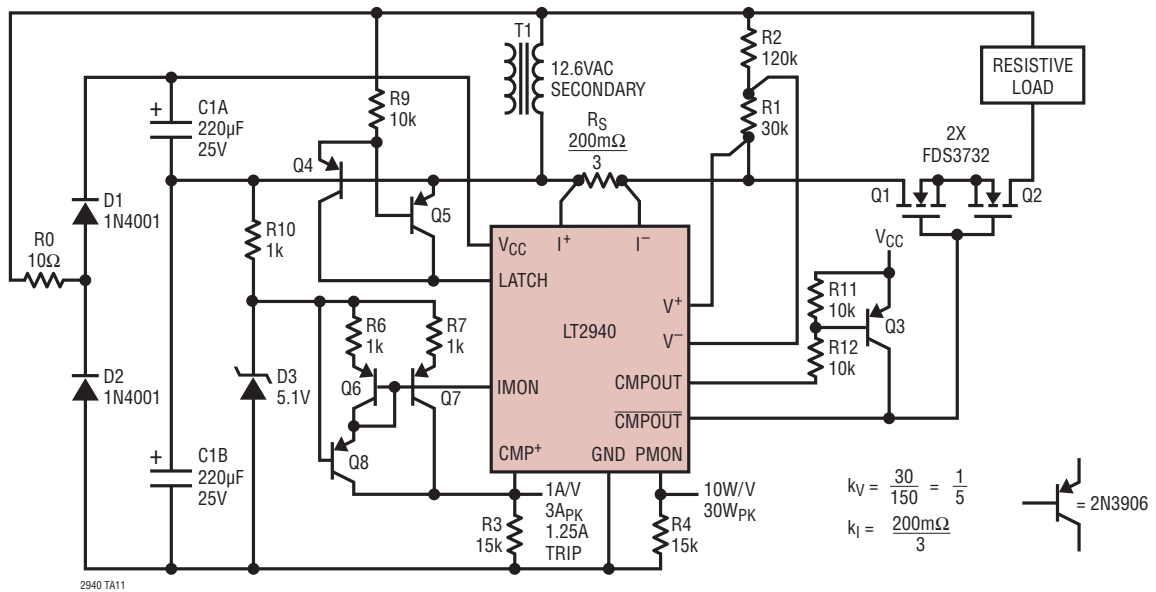

TYPICAL APPLICATIONS

AC Power and Current Monitor

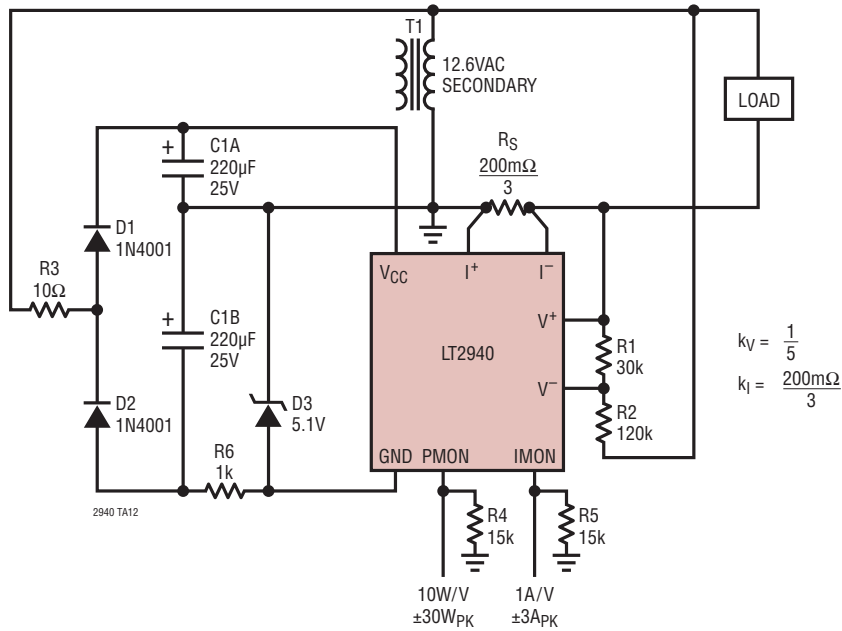

Fully Isolated AC Power and Current Monitor

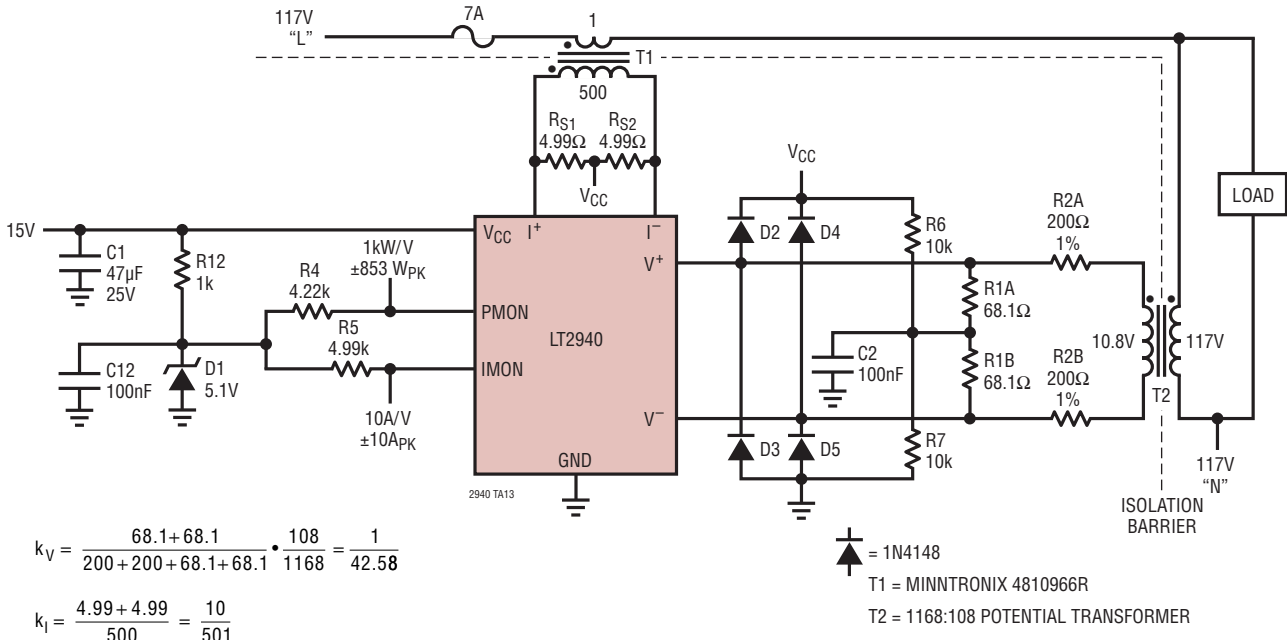

IN CONSTRUCTING THIS CIRCUIT, THE CUSTOMER AGREES THAT, IN ADDITION TO THE TERMS AND CONDITIONS ON LINEAR TECHNOLOGY CORPORATION'S (LTC) PURCHASE ORDER DOCUMENTS, LTC AND ANY OF ITS EMPLOYEES, AGENTS, REPRESENTATIVES AND CONTRACTORS SHALL HAVE NO LIABILITY, UNDER CONTRACT, TORT OR ANY OTHER LEGAL OR EQUITABLE THEORY OF RECOVERY, TO CUSTOMER OR ANY OF ITS EMPLOYEES, AGENTS, REPRESENTATIVES OR CONTRACTORS, FOR ANY PERSONAL INJURY, PROPERTY DAMAGE, OR ANY OTHER CLAIM (INCLUDING WITHOUT LIMITATION, FOR CONSEQUENTIAL OR INCIDENTAL DAMAGES) RESULTING FROM ANY USE OF THIS CIRCUIT, UNDER ANY CONDITIONS, FORESEEABLE OR OTHERWISE. CUSTOMER ALSO SHALL INDEMNIFY LTC AND ANY OF ITS EMPLOYEES, AGENTS, REPRESENTATIVES AND CONTRACTORS AGAINST ANY AND ALL LIABILITY, DAMAGES, COSTS AND EXPENSES, INCLUDING ATTORNEY'S FEES, ARISING FROM ANY THIRD PARTY CLAIMS FOR PERSONAL INJURY, PROPERTY DAMAGE, OR ANY OTHER CLAIM (INCLUDING WITHOUT LIMITATION, FOR CONSEQUENTIAL OR INCIDENTAL DAMAGES) RESULTING FROM ANY USE OF THIS CIRCUIT, UNDER ANY CONDITIONS, FORESEEABLE OR OTHERWISE.

**PACKAGE DESCRIPTION**

**DD Package**  
**12-Lead Plastic DFN (3mm × 3mm)**  
 (Reference LTC DWG # 05-08-1725 Rev A)

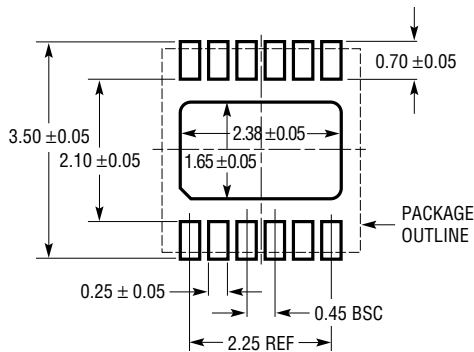

**RECOMMENDED SOLDER PAD PITCH AND DIMENSIONS**  
 APPLY SOLDER MASK TO AREAS THAT ARE NOT SOLDERED

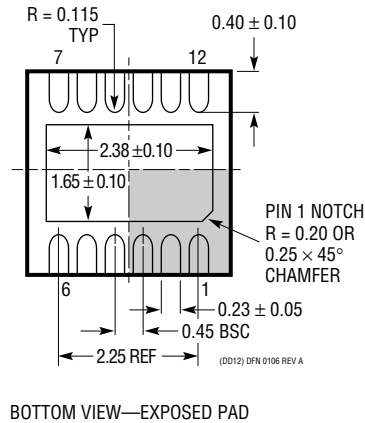
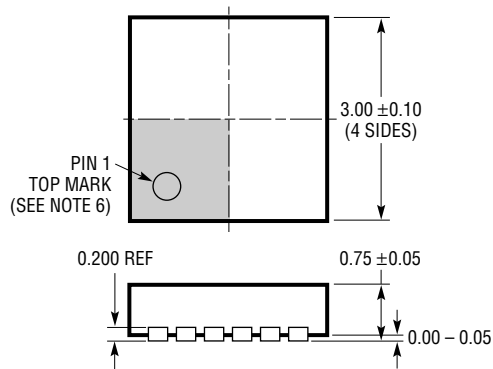

- NOTE:
1. DRAWING IS NOT A JEDEC PACKAGE OUTLINE
  2. DRAWING NOT TO SCALE
  3. ALL DIMENSIONS ARE IN MILLIMETERS
  4. DIMENSIONS OF EXPOSED PAD ON BOTTOM OF PACKAGE DO NOT INCLUDE MOLD FLASH. MOLD FLASH, IF PRESENT, SHALL NOT EXCEED 0.15mm ON ANY SIDE
  5. EXPOSED PAD AND TIE BARS SHALL BE SOLDER PLATED
  6. SHADED AREA IS ONLY A REFERENCE FOR PIN 1 LOCATION ON THE TOP AND BOTTOM OF PACKAGE

# PACKAGE DESCRIPTION

**MS Package**  
**12-Lead Plastic MSOP**  
 (Reference LTC DWG # 05-08-1668 Rev 0)

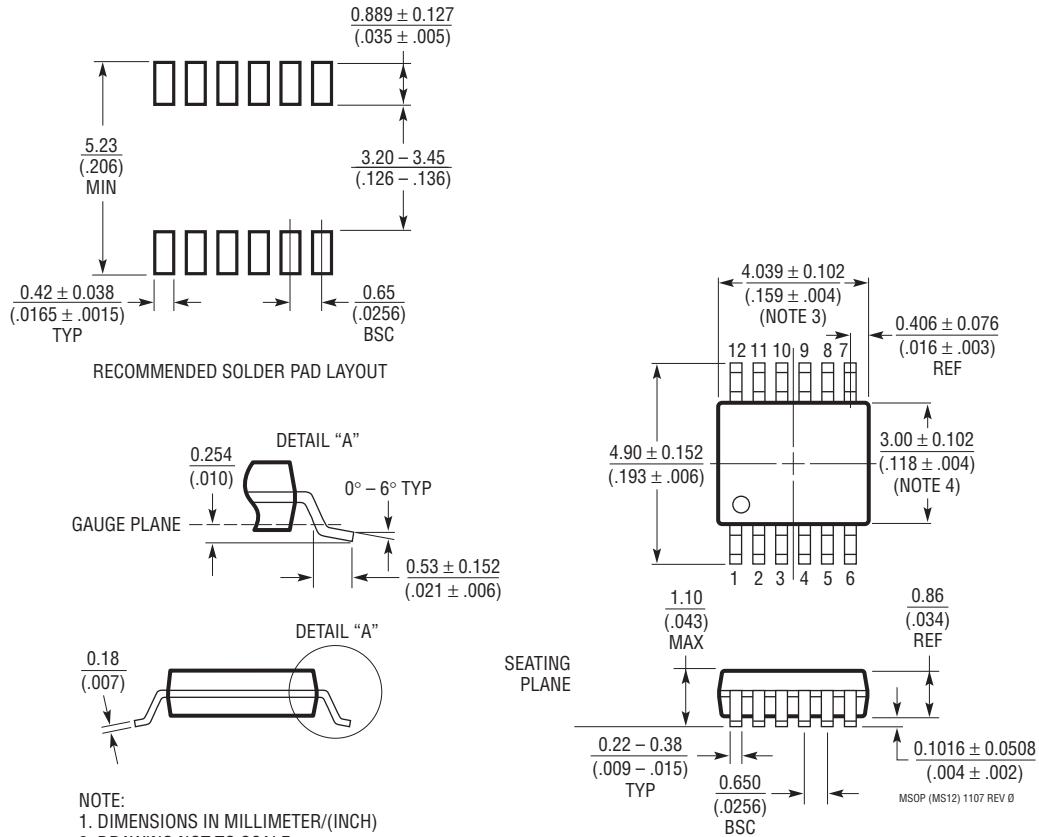

- NOTE:
1. DIMENSIONS IN MILLIMETER/(INCH)
  2. DRAWING NOT TO SCALE
  3. DIMENSION DOES NOT INCLUDE MOLD FLASH, PROTRUSIONS OR GATE BURRS.  
MOLD FLASH, PROTRUSIONS OR GATE BURRS SHALL NOT EXCEED 0.152mm (.006") PER SIDE
  4. DIMENSION DOES NOT INCLUDE INTERLEAD FLASH OR PROTRUSIONS.  
INTERLEAD FLASH OR PROTRUSIONS SHALL NOT EXCEED 0.152mm (.006") PER SIDE
  5. LEAD COPLANARITY (BOTTOM OF LEADS AFTER FORMING) SHALL BE 0.102mm (.004") MAX

Information furnished by Linear Technology Corporation is believed to be accurate and reliable. However, no responsibility is assumed for its use. Linear Technology Corporation makes no representation that the interconnection of its circuits as described herein will not infringe on existing patent rights.

## TYPICAL APPLICATION

### Integrating Watt-Hour Meter

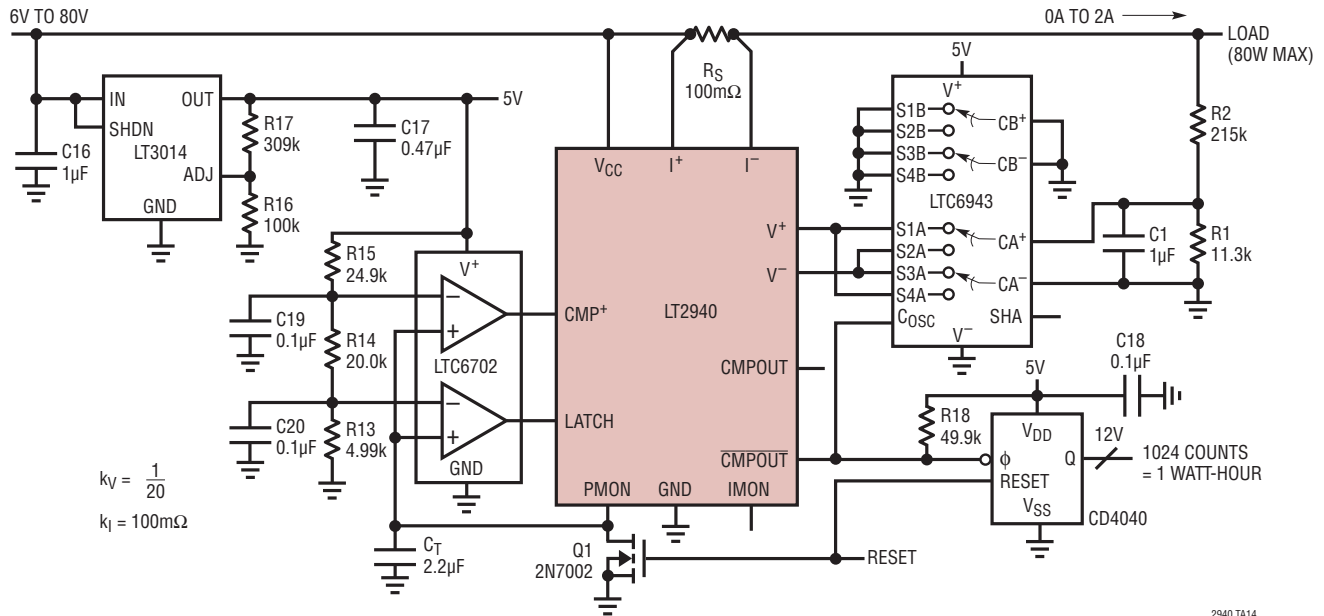

## RELATED PARTS

PART NUMBER	DESCRIPTION	COMMENTS
LTC1966	Precision Micropower Delta-Sigma RMS-to-DC Converter	2.7V to 12V Supply Voltage, 170μA Supply Current
LTC1968	Precision Wide Bandwidth RMS-to-DC Converter	4.5V to 6V Supply Voltage, 500kHz 3dB-Error BW
LTC6101/ LTC6101HV	High Voltage, High Side, Precision Current Sense Amplifiers	4V to 60V/5V to 100V, Gain Configurable, SOT-23
LTC6104	Bidirectional High Side, Precision Current Sense Amplifier	4V to 60V, Gain Configurable, 8-Pin MSOP
LTC6106	Low Cost, High Side Precision Current Sense Amplifier	2.7V to 36V, Gain Configurable, SOT23
LTC4151	High Voltage I <sup>2</sup> C Current and Voltage Monitor	Wide Operating Range: 7V to 80V
LTC4215	Positive Hot Swap Controller with ADC and I <sup>2</sup> C	8-Bit ADC Monitoring Current and Voltages, Supplies from 2.9V to 15V
LT4256-1/ LT4256-2	Positive 48V Hot Swap Controllers with Open-Circuit Detect	Foldback Current Limiting, Open-Circuit and Overcurrent Fault Output, Up to 80V Supply
LTC4260	Positive High Voltage Hot Swap Controller With ADC and I <sup>2</sup> C Monitoring	Wide Operating Range: 8.5V to 80V
LTC4261	Negative Voltage Hot Swap Controller With ADC and I <sup>2</sup> C Monitoring	Floating Topology Allows Very High Voltage Operation

## Looking for pricing, stock, or lifecycle information?

Click below to explore more details on WIN SOURCE:

 [View LT2940CMS#PBF on WIN SOURCE](#)

 [Linear Technology](#) Information

## Optimize Your Supply Chain with WIN SOURCE Solutions

-  Global Sourcing Solution
-  Obsolete Management
-  Cost Control Management
-  Shortage Management
-  Alternative Solution
-  Excess Inventory Management