



**THE DATASHEET OF  
CFRMT107-HF**



## CFRMT104-HF Thru. CFRMT107-HF

Reverse Voltage: 400 to 1000 Volts

Forward Current: 1.0 Amp

RoHS Device

Halogen Free

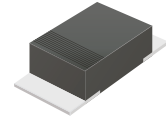

### Features

- Excellent power dissipation offers better reverse leakage current and thermal resistance.
- Low profile surface mounted application in order to optimize board space.
- Tiny plastic SMD package.
- High current capability.
- Fast switching for high efficiency.
- High surge current capability.
- Glass passivated chip junction.
- Lead-free parts meet RoHS requirements.

### Mechanical data

- Epoxy: UL94V-0 rated flame retardant.
- Case: Molded plastic, SOD-123H/MINI SMA
- Terminals: Solderable per MIL-STD-750, Method 2026.
- Polarity: Indicated by cathode band.
- Mounting Position: any
- Weight: 0.011 grams approx.

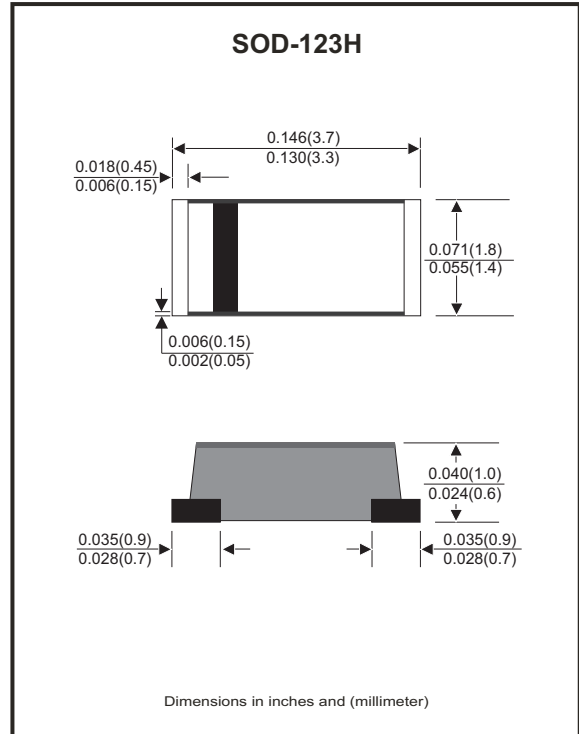

### Maximum Ratings and Electrical Characteristics (at T<sub>A</sub>=25°C unless otherwise noted)

Parameter	Symbol	CFRMT 104-HF	CFRMT 105-HF	CFRMT 107-HF	Unit
Max. Repetitive peak reverse voltage	V <sub>RRM</sub>	400	600	1000	V
Max. Continuous reverse voltage	V <sub>R</sub>	400	600	1000	V
Max. RMS voltage	V <sub>RMS</sub>	280	420	700	V
Max. Forward rectified current (See Fig.1)	I <sub>O</sub>	1.0			A
Max. Forward voltage @ I <sub>F</sub> =1.0A	V <sub>F</sub>	1.3			V
Max. Reverse recovery time (note 1)	T <sub>rr</sub>	150	250	500	ns
Max. Forward surge current 8.3ms single half sine-wave superimposed on rated load (JEDEC method)	I <sub>FSM</sub>	25			A
Max. Reverse current	V <sub>R</sub> =V <sub>RRM</sub> T <sub>J</sub> =25°C	5.0			μA
	V <sub>R</sub> =V <sub>RRM</sub> T <sub>J</sub> =125°C	100			
Typ. Thermal resistance Junction to ambient air	R <sub>θJA</sub>	42			°C/W
Typ. Diode Junction capacitance f=1MHz and applied 4V DC reverse voltage	C <sub>J</sub>	15			pF
Operating junction temperature	T <sub>J</sub>	-55 to +150			°C
Storage temperature range	T <sub>STG</sub>	-65 to +175			°C

Note 1. Reverse recovery time test condition, I<sub>F</sub>=0.5A, I<sub>R</sub>=1.0A, I<sub>RR</sub>=0.25A

Company reserves the right to improve product design, functions and reliability without notice.

REV: C

## Rating and Characteristic Curves (CFRMT104-HF Thru. CFRMT107-HF)

Fig.1 - Typical forward current derating curve

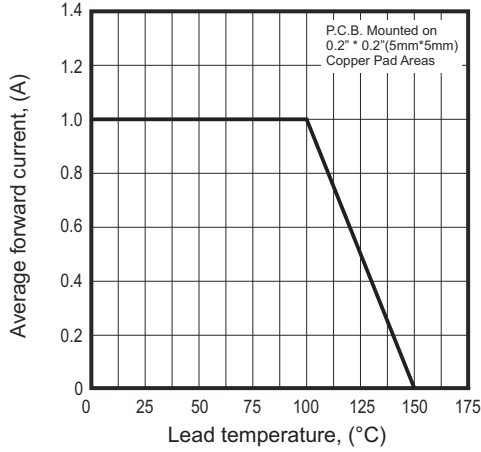

Fig.2 - Typical forward characteristics

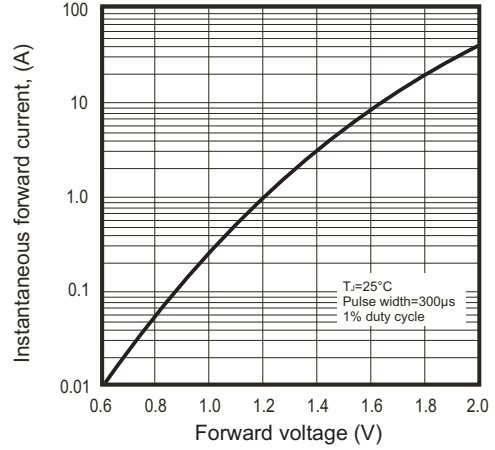
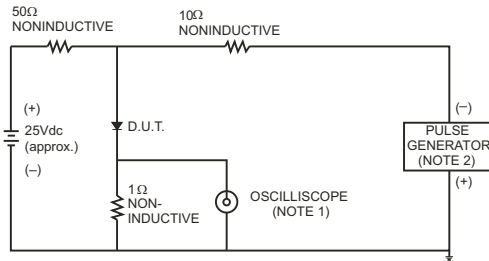

Fig.3 - Test Circuit Diagram and Reverse Recovery Time Characteristics



NOTES: 1. Rise Time= 7ns max., Input Impedance= 1 megohm.22pF.  
2. Rise Time= 10ns max., Source Impedance= 50 ohms.

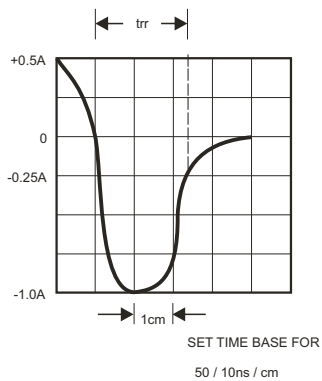

Fig.4 - Maximum Non-repetitive forward surge current

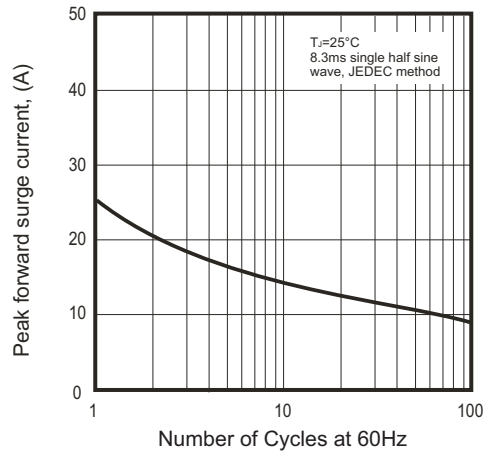
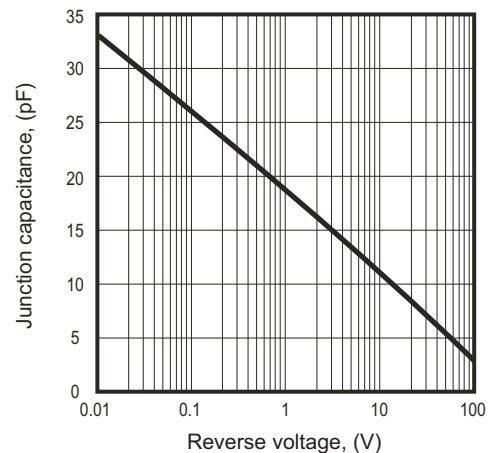
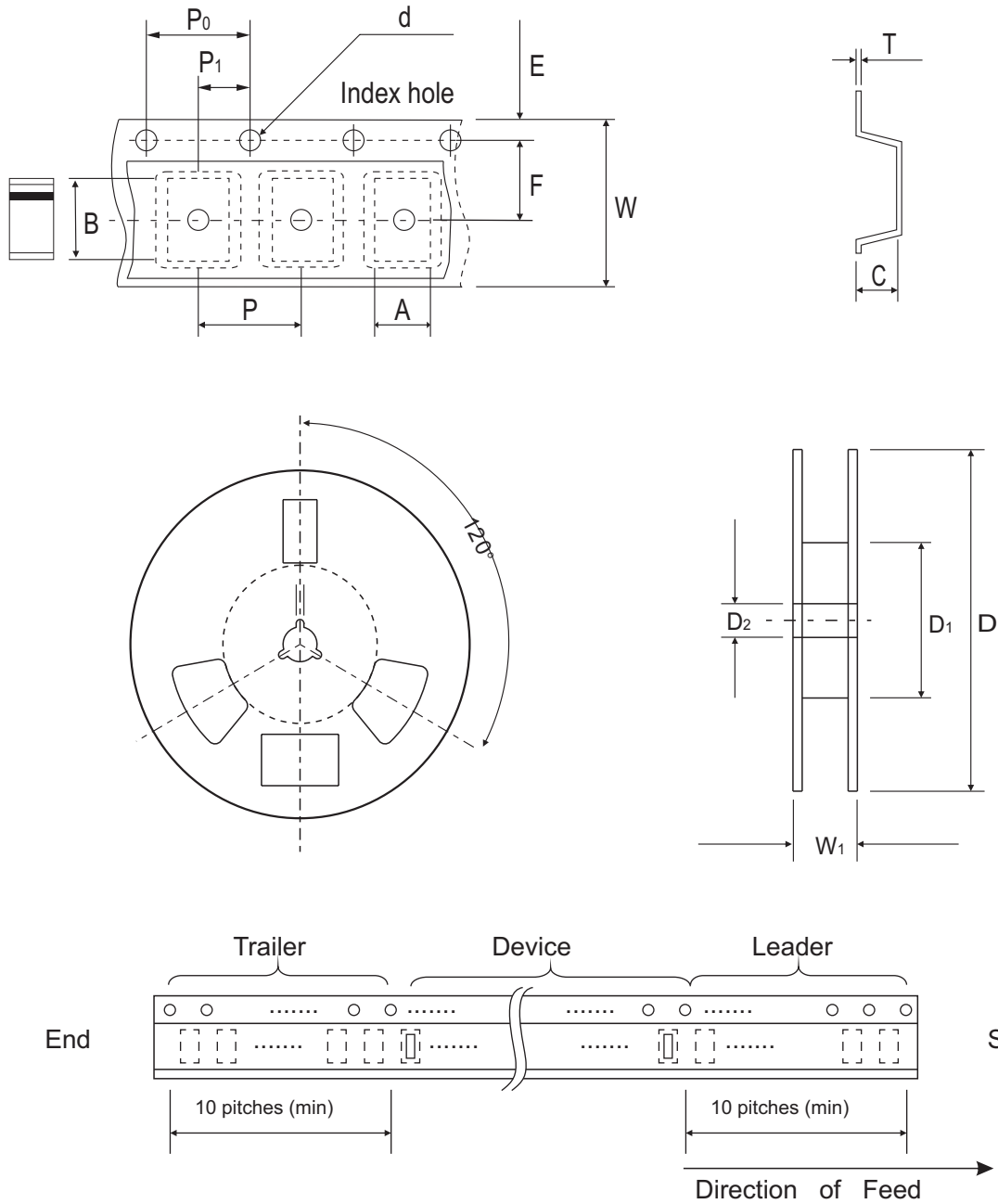

Fig.5 - Typical junction capacitance



## Reel Taping Specification



SOD-123H	SYMBOL	A	B	C	d	D	D1	D2
	(mm)	2.00 ± 0.10	3.85 ± 0.10	1.10 ± 0.10	1.50 ± 0.10	178.00 ± 2.00	62.00 (min)	13.00 ± 0.50
	(inch)	0.079 ± 0.004	0.152 ± 0.004	0.043 ± 0.004	0.059 ± 0.004	7.007 ± 0.079	2.441 (min)	0.512 ± 0.020

SOD-123H	SYMBOL	E	F	P	P0	P1	T	W	W1
	(mm)	1.75 ± 0.10	3.50 ± 0.10	4.00 ± 0.10	4.00 ± 0.10	2.00 ± 0.10	0.23 ± 0.10	8.00 ± 0.30	11.40 ± 1.00
	(inch)	0.069 ± 0.004	0.138 ± 0.004	0.157 ± 0.004	0.157 ± 0.004	0.079 ± 0.004	0.009 ± 0.04	0.315 ± 0.012	0.449 ± 0.039

## Pinning information

Pin	Simplified outline	Symbol
PIN 1 Cathode PIN 2 Anode		

## Marking Code

Part Number	Marking Code
CFRMT104-HF	F4
CFRMT105-HF	F5
CFRMT107-HF	F7



xx = Product type marking code

## Suggested PAD Layout

SIZE	SOD-123H	
	(mm)	(inch)
A	3.00	0.118
B	1.30	0.051
C	1.80	0.071
D	4.30	0.169
E	1.70	0.067

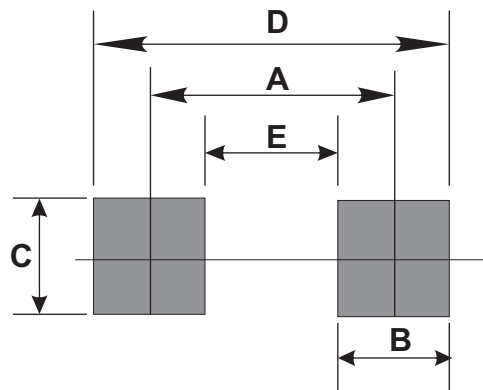



## Standard Packaging

Case Type	REEL PACK	
	REEL ( pcs )	Reel Size (inch)
SOD-123H	3,000	7

## Looking for pricing, stock, or lifecycle information?

Click below to explore more details on WIN SOURCE:

-  [View CFRMT107-HF on WIN SOURCE](#)
-  [Comchip Technology Information](#)

## Optimize Your Supply Chain with WIN SOURCE Solutions

-  Global Sourcing Solution
-  Obsolete Management
-  Cost Control Management
-  Shortage Management
-  Alternative Solution
-  Excess Inventory Management