



# THE DATASHEET OF SN74ALS191AN



# SN54ALS191A, SN74ALS191A SYNCHRONOUS 4-BIT UP/DOWN BINARY COUNTERS

SDAS210C – DECEMBER 1982 – REVISED JULY 1996

- Single Down/Up Count-Control Line
- Look-Ahead Circuitry Enhances Speed of Cascaded Counters
- Fully Synchronous in Count Modes
- Asynchronously Presetable With Load Control
- Package Options Include Plastic Small-Outline (D) Packages, Ceramic Chip Carriers (FK), and Standard Plastic (N) and Ceramic (J) 300-mil DIPs

## description

The 'ALS191A are synchronous 4-bit reversible up/down binary counters. Synchronous counting operation is provided by having all flip-flops clocked simultaneously so that the outputs change coincidentally with each other when instructed by the steering logic. This mode of operation eliminates the output counting spikes normally associated with asynchronous (ripple-clock) counters.

The outputs of the four flip-flops are triggered on a low-to-high-level transition of the clock (CLK) input if the count enable ( $\overline{\text{CTEN}}$ ) input is low. A high at  $\overline{\text{CTEN}}$  inhibits counting. The direction of the count is determined by the level of the down/up ( $\overline{\text{D/U}}$ ) input. When  $\overline{\text{D/U}}$  is low, the counter counts up, and when  $\overline{\text{D/U}}$  is high, the counter counts down.

These counters feature a fully independent clock circuit. Changes at the control inputs ( $\overline{\text{CTEN}}$  and  $\overline{\text{D/U}}$ ) that modify the operating mode have no effect on the contents of the counter until clocking occurs. The function of the counter is dictated solely by the conditions meeting the stable setup and hold times.

These counters are fully programmable. Each output can be preset to either level by placing a low on the  $\overline{\text{LOAD}}$  input and entering the desired data at the data inputs. The output changes to agree with the data inputs independently of the level of the clock input. This feature allows the counters to be used as modulo-N dividers by simply modifying the count length with the preset inputs.

CLK,  $\overline{\text{D/U}}$ , and  $\overline{\text{LOAD}}$  are buffered to lower the drive requirement, which significantly reduces the loading on (current required by) clock drivers, for long parallel words.

SN54ALS191A . . . J PACKAGE  
SN74ALS191A . . . D OR N PACKAGE  
(TOP VIEW)

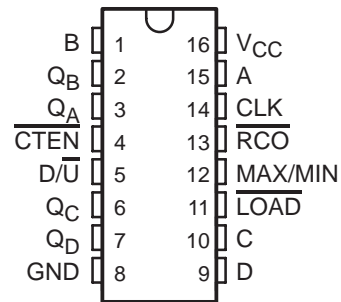

SN54ALS191A . . . FK PACKAGE  
(TOP VIEW)

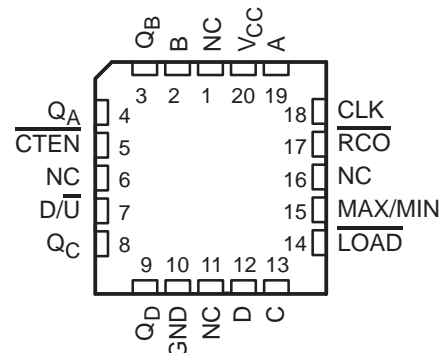

NC – No internal connection



Please be aware that an important notice concerning availability, standard warranty, and use in critical applications of Texas Instruments semiconductor products and disclaimers thereto appears at the end of this data sheet.

PRODUCTION DATA information is current as of publication date. Products conform to specifications per the terms of Texas Instruments standard warranty. Production processing does not necessarily include testing of all parameters.

 **TEXAS  
INSTRUMENTS**

POST OFFICE BOX 655303 • DALLAS, TEXAS 75265  
POST OFFICE BOX 1443 • HOUSTON, TEXAS 77251-1443

Copyright © 1996, Texas Instruments Incorporated

# SN54ALS191A, SN74ALS191A SYNCHRONOUS 4-BIT UP/DOWN BINARY COUNTERS

SDAS210C – DECEMBER 1982 – REVISED JULY 1996

## description (continued)

Two outputs are available to perform the cascading function: ripple clock and maximum/minimum count. The latter output produces a high-level output pulse with a duration approximately equal to one complete cycle of the clock while the count is minimum (0) counting down or maximum (15) counting up. The ripple-clock output ( $\overline{RCO}$ ) produces a low-level output pulse under those same conditions, but only while the clock input is low. The counter easily can be cascaded by feeding the ripple-clock output to the enable input of the succeeding counter if parallel clocking is used, or to the clock input if parallel enabling is used. The maximum/minimum count (MAX/MIN) output can be used to accomplish look ahead for high-speed operation.

The SN54ALS191A is characterized for operation over the full military temperature range of  $-55^{\circ}\text{C}$  to  $125^{\circ}\text{C}$ . The SN74ALS191A is characterized for operation from  $0^{\circ}\text{C}$  to  $70^{\circ}\text{C}$ .

## logic symbol†

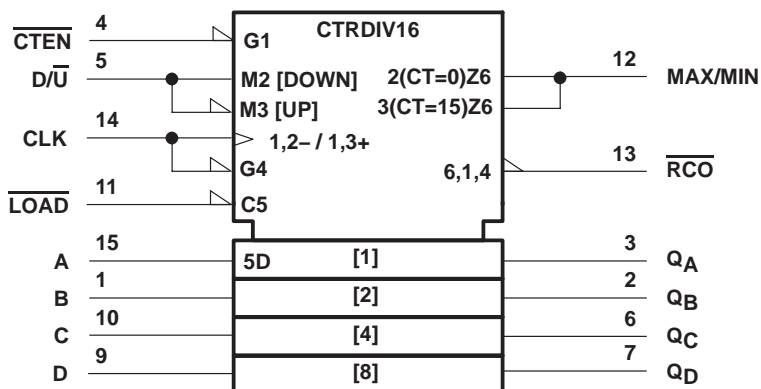

† This symbol is in accordance with ANSI/IEEE Std 91-1984 and IEC Publication 617-12. Pin numbers shown are for the D, J, and N packages.

# SN54ALS191A, SN74ALS191A SYNCHRONOUS 4-BIT UP/DOWN BINARY COUNTERS

SDAS210C – DECEMBER 1982 – REVISED JULY 1996

logic diagram (positive logic)

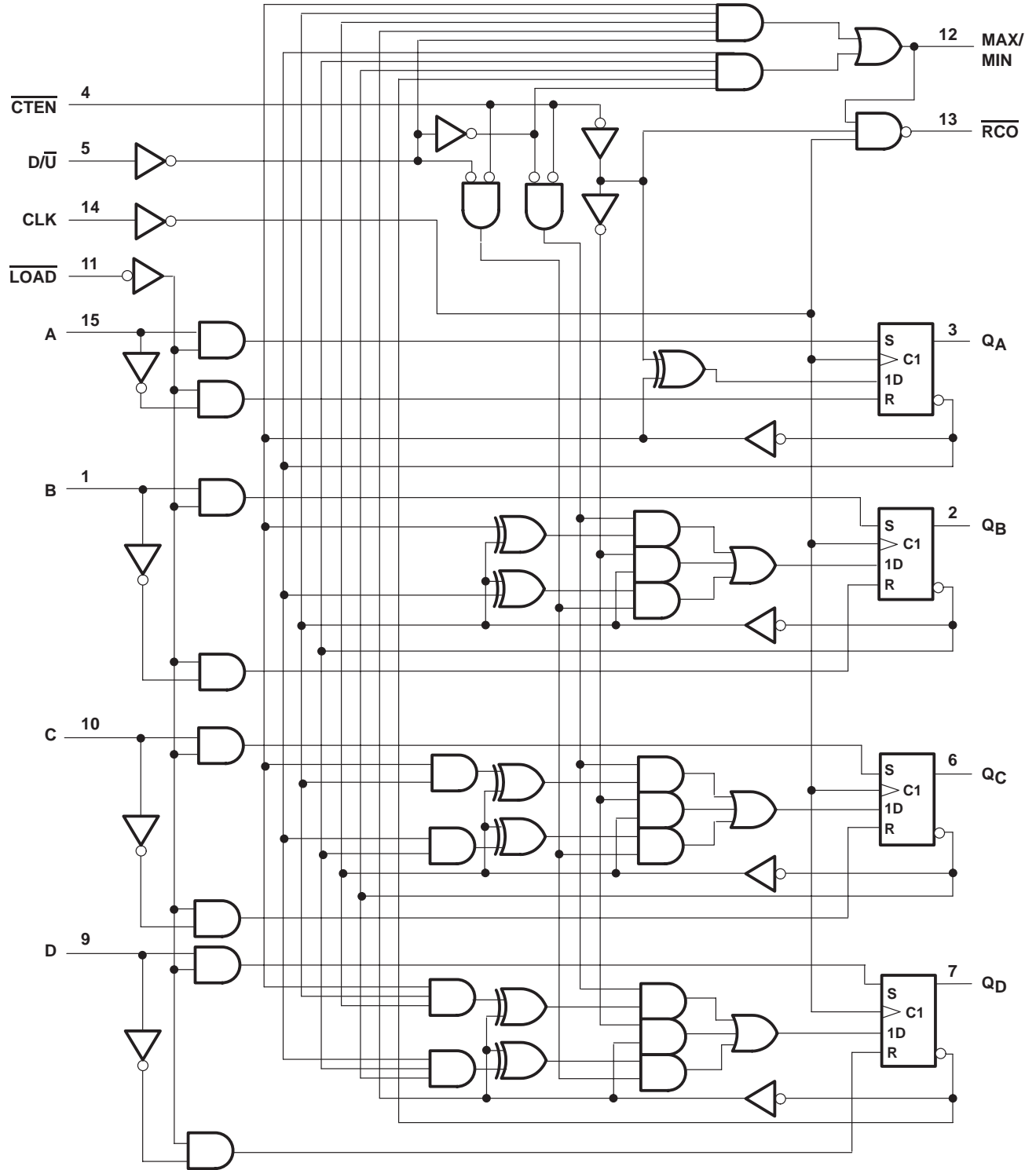

Pin numbers shown are for the D, J, and N packages.



# SN54ALS191A, SN74ALS191A SYNCHRONOUS 4-BIT UP/DOWN BINARY COUNTERS

SDAS210C – DECEMBER 1982 – REVISED JULY 1996

## typical load, count, and inhibit sequences

The following sequence is illustrated below:

1. Load (preset) to binary 13
2. Count up to 14, 15 (maximum), 0, 1, and 2
3. Inhibit
4. Count down to 1, 0 (minimum), 15, 14, and 13

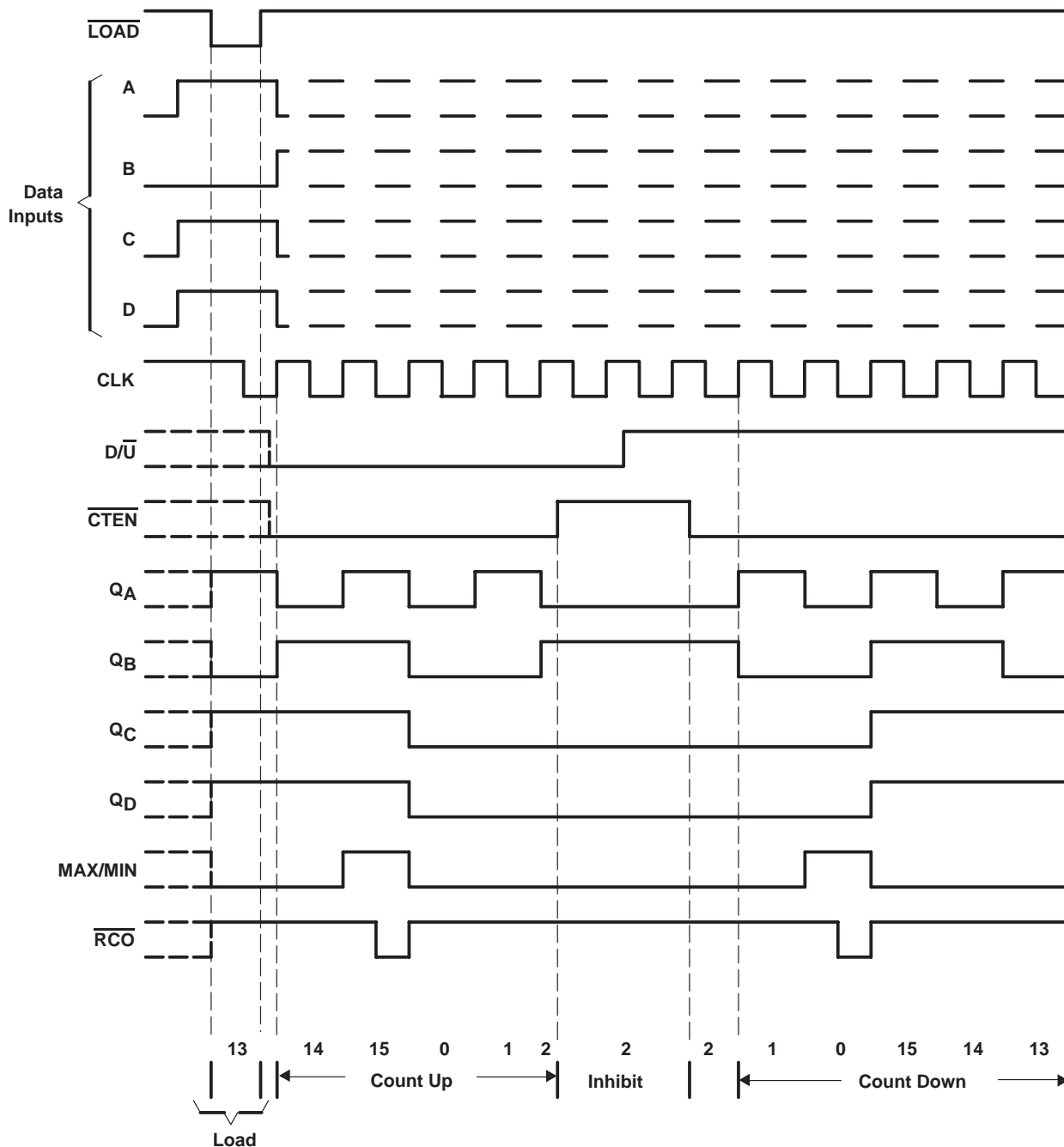

# SN54ALS191A, SN74ALS191A SYNCHRONOUS 4-BIT UP/DOWN BINARY COUNTERS

SDAS210C – DECEMBER 1982 – REVISED JULY 1996

## absolute maximum ratings over operating free-air temperature range (unless otherwise noted)†

Supply voltage, $V_{CC}$ .....	7 V
Input voltage, $V_I$ .....	7 V
Operating free-air temperature range, $T_A$ : SN54ALS191A .....	–55°C to 125°C
SN74ALS191A .....	0°C to 70°C
Storage temperature range, $T_{stg}$ .....	–65°C to 150°C

† Stresses beyond those listed under “absolute maximum ratings” may cause permanent damage to the device. These are stress ratings only, and functional operation of the device at these or any other conditions beyond those indicated under “recommended operating conditions” is not implied. Exposure to absolute-maximum-rated conditions for extended periods may affect device reliability.

## recommended operating conditions

		SN54ALS191A			SN74ALS191A			UNIT
		MIN	NOM	MAX	MIN	NOM	MAX	
$V_{CC}$	Supply voltage	4.5	5	5.5	4.5	5	5.5	V
$V_{IH}$	High-level input voltage	2			2			V
$V_{IL}$	Low-level input voltage			0.7			0.8	V
$I_{OH}$	High-level output current			–0.4			–0.4	mA
$I_{OL}$	Low-level output current			4			8	mA
$f_{clock}$	Clock frequency	0		20	0		30	MHz
$t_w$	Pulse duration	CLK high or low		20	16.5		ns	
		LOAD low		25	20			
$t_{su}$	Setup time	Data before $\overline{LOAD}\uparrow$		25	20		ns	
		$\overline{CTEN}$ before CLK $\uparrow$		45	20			
		D/ $\overline{U}$ before CLK $\uparrow$		30	20			
		$\overline{LOAD}$ inactive before CLK $\uparrow$		20	20			
$t_h$	Hold time	Data after $\overline{LOAD}\uparrow$		5	5		ns	
		$\overline{CTEN}$ after CLK $\uparrow$		0	0			
		D/ $\overline{U}$ after CLK $\uparrow$		0	0			
$T_A$	Operating free-air temperature	–55		125	0		70	°C



# SN54ALS191A, SN74ALS191A SYNCHRONOUS 4-BIT UP/DOWN BINARY COUNTERS

SDAS210C – DECEMBER 1982 – REVISED JULY 1996

electrical characteristics over recommended operating free-air temperature range (unless otherwise noted)

PARAMETER	TEST CONDITIONS		SN54ALS191A		SN74ALS191A		UNIT
			MIN	TYP†	MAX	MIN	
V <sub>IK</sub>	V <sub>CC</sub> = 4.5 V, I <sub>I</sub> = -18 mA		-1.5		-1.5		V
V <sub>OH</sub>	V <sub>CC</sub> = 4.5 V to 5.5 V, I <sub>OH</sub> = -0.4 mA		V <sub>CC</sub> - 2		V <sub>CC</sub> - 2		V
V <sub>OL</sub>	V <sub>CC</sub> = 4.5 V	I <sub>OL</sub> = 4 mA	0.25	0.4	0.25	0.4	
		I <sub>OL</sub> = 8 mA			0.35	0.5	
I <sub>I</sub>	V <sub>CC</sub> = 5.5 V, V <sub>I</sub> = 7 V		0.2		0.1		mA
I <sub>IH</sub>	V <sub>CC</sub> = 5.5 V, V <sub>I</sub> = 2.7 V		20		20		μA
I <sub>IL</sub>	CTEN or CLK	V <sub>CC</sub> = 5.5 V, V <sub>I</sub> = 0.4 V	-0.2		-0.2		mA
	All others		-0.2		-0.1		
I <sub>O</sub> ‡	V <sub>CC</sub> = 5.5 V, V <sub>O</sub> = 2.25 V		-20	-112	-30	-112	mA
I <sub>CC</sub>	V <sub>CC</sub> = 5.5 V, All inputs at 0		12	22	12	22	mA

† All typical values are at V<sub>CC</sub> = 5 V, T<sub>A</sub> = 25°C.

‡ The output conditions have been chosen to produce a current that closely approximates one half of the true short-circuit output current, I<sub>OS</sub>.

## switching characteristics (see Figure 1)

PARAMETER	FROM (OUTPUT)	TO (OUTPUT)	V <sub>CC</sub> = 4.5 V to 5.5 V, C <sub>L</sub> = 50 pF, R <sub>L</sub> = 500 Ω, T <sub>A</sub> = MIN to MAX§				UNIT
			SN54ALS191A		SN74ALS191A		
			MIN	MAX	MIN	MAX	
f <sub>max</sub>			20		30	MHz	
t <sub>PLH</sub>	LOAD	Any Q	7	37	7	30	ns
t <sub>PHL</sub>			8	34	8	30	
t <sub>PLH</sub>	A, B, C, D	Any Q	3	25	3	21	ns
t <sub>PHL</sub>			4	25	4	21	
t <sub>PLH</sub>	CLK	RCO	5	24	5	20	ns
t <sub>PHL</sub>			5	25	5	20	
t <sub>PLH</sub>	CLK	Any Q	3	26	3	18	ns
t <sub>PHL</sub>			3	22	3	18	
t <sub>PLH</sub>	CLK	MAX/MIN	8	37	8	31	ns
t <sub>PHL</sub>			8	34	8	31	
t <sub>PLH</sub>	D $\bar{U}$	RCO	8	45	8	37	ns
t <sub>PHL</sub>			10	36	10	28	
t <sub>PLH</sub>	D $\bar{U}$	MAX/MIN	8	35	8	25	ns
t <sub>PHL</sub>			8	30	8	25	
t <sub>PLH</sub>	CTEN	RCO	4	21	4	18	ns
t <sub>PHL</sub>			4	23	4	18	

§ For conditions shown as MIN or MAX, use the appropriate value specified under recommended operating conditions.



# SN54ALS191A, SN74ALS191A SYNCHRONOUS 4-BIT UP/DOWN BINARY COUNTERS

SDAS210C – DECEMBER 1982 – REVISED JULY 1996

## PARAMETER MEASUREMENT INFORMATION SERIES 54ALS/74ALS AND 54AS/74AS DEVICES

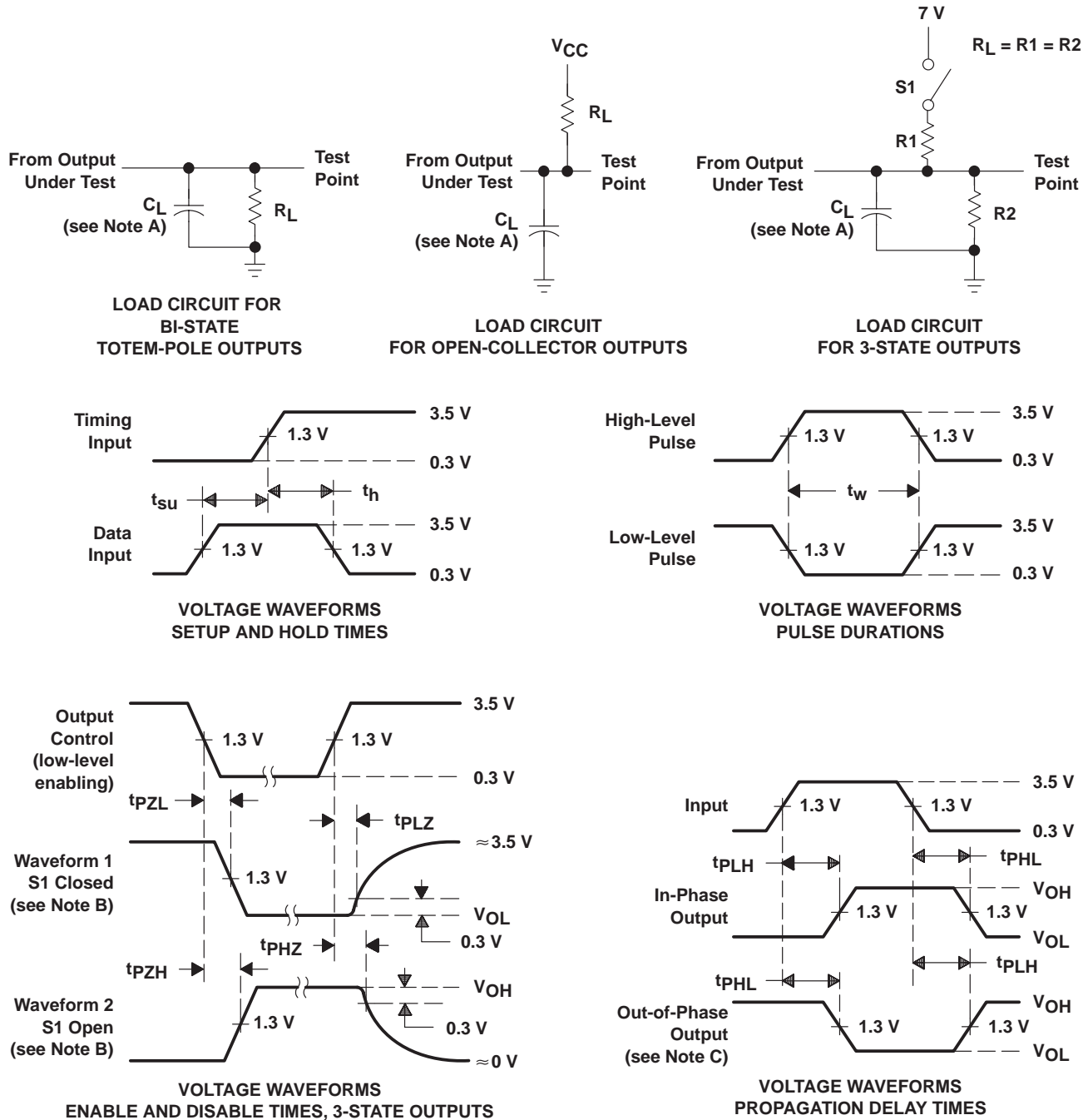

- NOTES: A.  $C_L$  includes probe and jig capacitance.  
 B. Waveform 1 is for an output with internal conditions such that the output is low except when disabled by the output control. Waveform 2 is for an output with internal conditions such that the output is high except when disabled by the output control.  
 C. When measuring propagation delay items of 3-state outputs, switch S1 is open.  
 D. All input pulses have the following characteristics:  $PRR \leq 1$  MHz,  $t_r = t_f = 2$  ns, duty cycle = 50%.  
 E. The outputs are measured one at a time with one transition per measurement.

Figure 1. Load Circuits and Voltage Waveforms



**PACKAGING INFORMATION**

Orderable Device	Status (1)	Package Type	Package Drawing	Pins	Package Qty	Eco Plan (2)	Lead finish/ Ball material (6)	MSL Peak Temp (3)	Op Temp (°C)	Device Marking (4/5)	Samples
5962-86840012A	ACTIVE	LCCC	FK	20	55	Non-RoHS & Green	SNPB	N / A for Pkg Type	-55 to 125	5962-86840012A SNJ54ALS 191AFK	<a href="#">Samples</a>
5962-8684001EA	ACTIVE	CDIP	J	16	25	Non-RoHS & Green	SNPB	N / A for Pkg Type	-55 to 125	5962-8684001EA SNJ54ALS191AJ	<a href="#">Samples</a>
5962-8684001FA	ACTIVE	CFP	W	16	25	Non-RoHS & Green	SNPB	N / A for Pkg Type	-55 to 125	5962-8684001FA SNJ54ALS191AW	<a href="#">Samples</a>
SN74ALS191ADR	ACTIVE	SOIC	D	16	2500	RoHS & Green	NIPDAU	Level-1-260C-UNLIM	0 to 70	ALS191A	<a href="#">Samples</a>
SN74ALS191AN	ACTIVE	PDIP	N	16	25	RoHS & Green	NIPDAU	N / A for Pkg Type	0 to 70	SN74ALS191AN	<a href="#">Samples</a>
SNJ54ALS191AFK	ACTIVE	LCCC	FK	20	55	Non-RoHS & Green	SNPB	N / A for Pkg Type	-55 to 125	5962-86840012A SNJ54ALS 191AFK	<a href="#">Samples</a>
SNJ54ALS191AJ	ACTIVE	CDIP	J	16	25	Non-RoHS & Green	SNPB	N / A for Pkg Type	-55 to 125	5962-8684001EA SNJ54ALS191AJ	<a href="#">Samples</a>
SNJ54ALS191AW	ACTIVE	CFP	W	16	25	Non-RoHS & Green	SNPB	N / A for Pkg Type	-55 to 125	5962-8684001FA SNJ54ALS191AW	<a href="#">Samples</a>

(1) The marketing status values are defined as follows:

**ACTIVE:** Product device recommended for new designs.

**LIFEBUY:** TI has announced that the device will be discontinued, and a lifetime-buy period is in effect.

**NRND:** Not recommended for new designs. Device is in production to support existing customers, but TI does not recommend using this part in a new design.

**PREVIEW:** Device has been announced but is not in production. Samples may or may not be available.

**OBSOLETE:** TI has discontinued the production of the device.

(2) **RoHS:** TI defines "RoHS" to mean semiconductor products that are compliant with the current EU RoHS requirements for all 10 RoHS substances, including the requirement that RoHS substance do not exceed 0.1% by weight in homogeneous materials. Where designed to be soldered at high temperatures, "RoHS" products are suitable for use in specified lead-free processes. TI may reference these types of products as "Pb-Free".

**RoHS Exempt:** TI defines "RoHS Exempt" to mean products that contain lead but are compliant with EU RoHS pursuant to a specific EU RoHS exemption.

**Green:** TI defines "Green" to mean the content of Chlorine (Cl) and Bromine (Br) based flame retardants meet JS709B low halogen requirements of <=1000ppm threshold. Antimony trioxide based flame retardants must also meet the <=1000ppm threshold requirement.

(3) MSL, Peak Temp. - The Moisture Sensitivity Level rating according to the JEDEC industry standard classifications, and peak solder temperature.

(4) There may be additional marking, which relates to the logo, the lot trace code information, or the environmental category on the device.

(5) Multiple Device Markings will be inside parentheses. Only one Device Marking contained in parentheses and separated by a "~" will appear on a device. If a line is indented then it is a continuation of the previous line and the two combined represent the entire Device Marking for that device.

(6) Lead finish/Ball material - Orderable Devices may have multiple material finish options. Finish options are separated by a vertical ruled line. Lead finish/Ball material values may wrap to two lines if the finish value exceeds the maximum column width.

**Important Information and Disclaimer:**The information provided on this page represents TI's knowledge and belief as of the date that it is provided. TI bases its knowledge and belief on information provided by third parties, and makes no representation or warranty as to the accuracy of such information. Efforts are underway to better integrate information from third parties. TI has taken and continues to take reasonable steps to provide representative and accurate information but may not have conducted destructive testing or chemical analysis on incoming materials and chemicals. TI and TI suppliers consider certain information to be proprietary, and thus CAS numbers and other limited information may not be available for release.

In no event shall TI's liability arising out of such information exceed the total purchase price of the TI part(s) at issue in this document sold by TI to Customer on an annual basis.

**OTHER QUALIFIED VERSIONS OF SN54ALS191A, SN74ALS191A :**

- Catalog : [SN74ALS191A](#)
- Military : [SN54ALS191A](#)

NOTE: Qualified Version Definitions:

- Catalog - TI's standard catalog product
- Military - QML certified for Military and Defense Applications

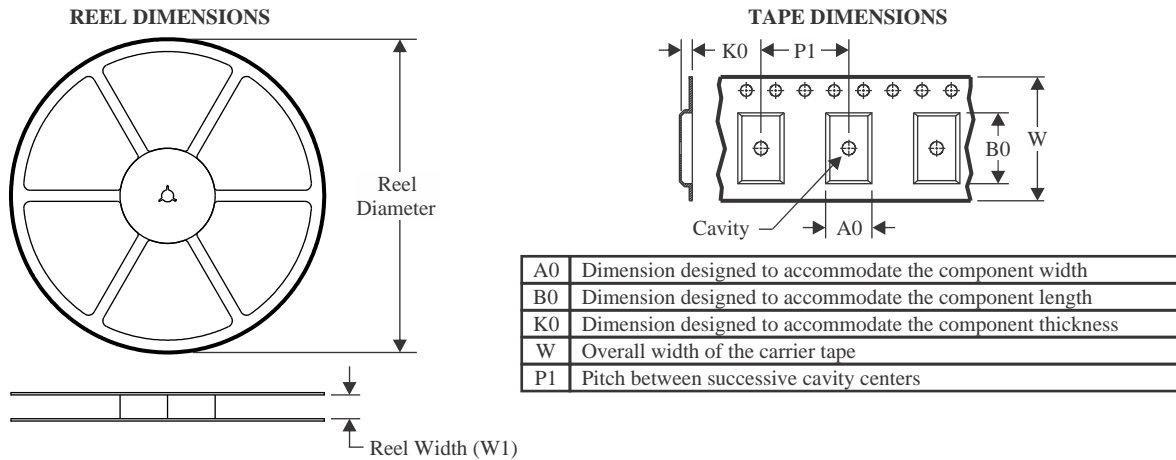
**TAPE AND REEL INFORMATION**

**QUADRANT ASSIGNMENTS FOR PIN 1 ORIENTATION IN TAPE**

\*All dimensions are nominal

Device	Package Type	Package Drawing	Pins	SPQ	Reel Diameter (mm)	Reel Width W1 (mm)	A0 (mm)	B0 (mm)	K0 (mm)	P1 (mm)	W (mm)	Pin1 Quadrant
SN74ALS191ADR	SOIC	D	16	2500	330.0	16.4	6.5	10.3	2.1	8.0	16.0	Q1

**TAPE AND REEL BOX DIMENSIONS**

\*All dimensions are nominal

Device	Package Type	Package Drawing	Pins	SPQ	Length (mm)	Width (mm)	Height (mm)
SN74ALS191ADR	SOIC	D	16	2500	340.5	336.1	32.0

**TUBE**

\*All dimensions are nominal

Device	Package Name	Package Type	Pins	SPQ	L (mm)	W (mm)	T (μm)	B (mm)
5962-86840012A	FK	LCCC	20	55	506.98	12.06	2030	NA
5962-8684001FA	W	CFP	16	25	506.98	26.16	6220	NA
SN74ALS191AN	N	PDIP	16	25	506	13.97	11230	4.32
SN74ALS191AN	N	PDIP	16	25	506	13.97	11230	4.32
SNJ54ALS191AFK	FK	LCCC	20	55	506.98	12.06	2030	NA
SNJ54ALS191AW	W	CFP	16	25	506.98	26.16	6220	NA

W (R-GDFP-F16)

CERAMIC DUAL FLATPACK



- NOTES:
- A. All linear dimensions are in inches (millimeters).
  - B. This drawing is subject to change without notice.
  - C. This package can be hermetically sealed with a ceramic lid using glass frit.
  - D. Index point is provided on cap for terminal identification only.
  - E. Falls within MIL STD 1835 GDFP2-F16

## GENERIC PACKAGE VIEW

**FK 20**

**LCCC - 2.03 mm max height**

8.89 x 8.89, 1.27 mm pitch

LEADLESS CERAMIC CHIP CARRIER

This image is a representation of the package family, actual package may vary.  
Refer to the product data sheet for package details.



4229370VA\

J (R-GDIP-T\*\*)

14 LEADS SHOWN

CERAMIC DUAL IN-LINE PACKAGE



DIM \ PINS **	14	16	18	20
A	0.300 (7,62) BSC	0.300 (7,62) BSC	0.300 (7,62) BSC	0.300 (7,62) BSC
B MAX	0.785 (19,94)	.840 (21,34)	0.960 (24,38)	1.060 (26,92)
B MIN	—	—	—	—
C MAX	0.300 (7,62)	0.300 (7,62)	0.310 (7,87)	0.300 (7,62)
C MIN	0.245 (6,22)	0.245 (6,22)	0.220 (5,59)	0.245 (6,22)



4040083/F 03/03

- NOTES:
- All linear dimensions are in inches (millimeters).
  - This drawing is subject to change without notice.
  - This package is hermetically sealed with a ceramic lid using glass frit.
  - Index point is provided on cap for terminal identification only on press ceramic glass frit seal only.
  - Falls within MIL STD 1835 GDIP1-T14, GDIP1-T16, GDIP1-T18 and GDIP1-T20.

N (R-PDIP-T\*\*)

PLASTIC DUAL-IN-LINE PACKAGE

16 PINS SHOWN



4040049/E 12/2002

- NOTES:
- A. All linear dimensions are in inches (millimeters).
  - B. This drawing is subject to change without notice.
  - (C) Falls within JEDEC MS-001, except 18 and 20 pin minimum body length (Dim A).
  - (D) The 20 pin end lead shoulder width is a vendor option, either half or full width.

D (R-PDSO-G16)

PLASTIC SMALL OUTLINE



- NOTES:
- A. All linear dimensions are in inches (millimeters).
  - B. This drawing is subject to change without notice.
  - C. Body length does not include mold flash, protrusions, or gate burrs. Mold flash, protrusions, or gate burrs shall not exceed 0.006 (0,15) each side.
  - D. Body width does not include interlead flash. Interlead flash shall not exceed 0.017 (0,43) each side.
  - E. Reference JEDEC MS-012 variation AC.

## IMPORTANT NOTICE AND DISCLAIMER

TI PROVIDES TECHNICAL AND RELIABILITY DATA (INCLUDING DATA SHEETS), DESIGN RESOURCES (INCLUDING REFERENCE DESIGNS), APPLICATION OR OTHER DESIGN ADVICE, WEB TOOLS, SAFETY INFORMATION, AND OTHER RESOURCES "AS IS" AND WITH ALL FAULTS, AND DISCLAIMS ALL WARRANTIES, EXPRESS AND IMPLIED, INCLUDING WITHOUT LIMITATION ANY IMPLIED WARRANTIES OF MERCHANTABILITY, FITNESS FOR A PARTICULAR PURPOSE OR NON-INFRINGEMENT OF THIRD PARTY INTELLECTUAL PROPERTY RIGHTS.

These resources are intended for skilled developers designing with TI products. You are solely responsible for (1) selecting the appropriate TI products for your application, (2) designing, validating and testing your application, and (3) ensuring your application meets applicable standards, and any other safety, security, regulatory or other requirements.

These resources are subject to change without notice. TI grants you permission to use these resources only for development of an application that uses the TI products described in the resource. Other reproduction and display of these resources is prohibited. No license is granted to any other TI intellectual property right or to any third party intellectual property right. TI disclaims responsibility for, and you will fully indemnify TI and its representatives against, any claims, damages, costs, losses, and liabilities arising out of your use of these resources.

TI's products are provided subject to [TI's Terms of Sale](#) or other applicable terms available either on [ti.com](https://www.ti.com) or provided in conjunction with such TI products. TI's provision of these resources does not expand or otherwise alter TI's applicable warranties or warranty disclaimers for TI products.

TI objects to and rejects any additional or different terms you may have proposed.

Mailing Address: Texas Instruments, Post Office Box 655303, Dallas, Texas 75265  
Copyright © 2024, Texas Instruments Incorporated

## Looking for pricing, stock, or lifecycle information?

Click below to explore more details on WIN SOURCE:

 [View SN74ALS191AN](#) on WIN SOURCE

 [Texas Instruments](#) Information

## Optimize Your Supply Chain with WIN SOURCE Solutions

-  Global Sourcing Solution
-  Obsolete Management
-  Cost Control Management
-  Shortage Management
-  Alternative Solution
-  Excess Inventory Management