



PIC12F529T39A

14-Pin, 8-Bit Flash Microcontroller

High-Performance RISC CPU

- Only 34 Single-Word Instructions
- All Single-Cycle Instructions except for Program Branches which are Two-Cycle
- Four-Level Deep Hardware Stack
- Direct, Indirect and Relative Addressing modes for Data and Instructions
- Operating Speed:
 - DC – 8 MHz internal clock
 - DC – 500 ns instruction cycle

Special Microcontroller Features

- 8 MHz Precision Internal Oscillator:
 - Factory-calibrated to $\pm 1\%$
- In-Circuit Serial Programming™ (ICSP™)
- Power-on Reset (POR)
- Device Reset Timer (DRT)
- Watchdog Timer (WDT) with Dedicated On-Chip RC Oscillator for Reliable Operation
- Programmable Code Protection
- Multiplexed MCLR Input Pin
- Internal Weak Pull-ups on I/O Pins
- Power-Saving Sleep mode
- Wake-up from Sleep on Pin Change
- Selectable Oscillator Options:
 - INTRC: 4 MHz or 8 MHz precision internal RC oscillator
 - EXTRC: External low-cost RC oscillator
 - XT: Standard crystal/resonator
 - LP: Power-saving, low-frequency crystal

Low-Power Features/CMOS Technology

- Standby Current:
 - 225 nA @ 2.0V, RF Sleep, typical
- Operating Current:
 - 175 μ A @ 4 MHz, 2.0V, RF Sleep, typical
 - 9.17 mA @ 4 MHz, 2.0V, RF on at +0 dBm, typical
 - 15.17 mA @ 4 MHz, 2.0V, RF on at +10 dBm, typical
- Watchdog Timer Current:
 - 1 μ A @ 2.0V, typical
- High Endurance Program and Flash Data Memory cells:
 - 100,000 write program memory endurance
 - 1,000,000 write Flash data memory endurance
 - Program and Flash data retention: >40 years
- Fully Static Design
- Operating Voltage Range: 2.0V to 3.7V
- Industrial temperature range: -40°C to +85°C

RF Transmitter

- Fully-Integrated Transmitter
- FSK Operation up to 100 kbps
- OOK Operation up to 10 kbps
- Frequency-Agile Operation in 310, 433, 868 and 915 MHz bands
- Configurable Output Power: +10 dBm, 0 dBm

Peripheral Features

- Six I/O Pins:
 - Five I/O pins with individual direction control
 - One input-only pin
 - High-current sink/source for direct LED drive
- 8-Bit Real-Time Clock/Counter (TMR0) with 8-Bit Programmable Prescaler

PIC12F529T39A

FIGURE 1: 14-PIN TSSOP

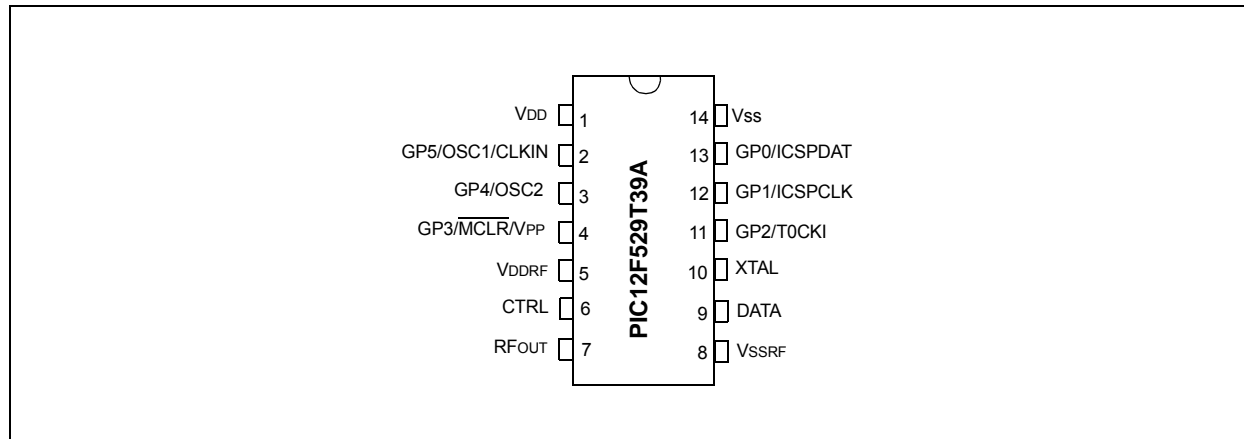

PIC12F529T39A Family Types

Device	Program Memory	Data Memory		I/O	RF Transmitter	Comparators	Timers (8-bit)	8-Bit A/D Channels
	Flash (words)	SRAM (bytes)	Flash (bytes)					
PIC12F529T39A	1536	201	64	6	1	0	1	0
PIC12LF1840T39A								

Data Sheet Index: (Unshaded devices are described in this document.)

1: DS40001636 [PIC12LF1840T39A Data Sheet, 8-Bit Flash Microcontroller with XLP](#)

Table of Contents

1.0	General Description	7
2.0	PIC12F529T39A Device Varieties	9
3.0	Architectural Overview	11
4.0	Memory Organization	15
5.0	Flash Data Memory	23
6.0	I/O Port	25
7.0	Timer0 Module and TMR0 Register	33
8.0	Special Features Of The CPU	39
9.0	RF Transmitter	51
10.0	Instruction Set Summary	63
11.0	Development Support	71
12.0	Electrical Characteristics	75
13.0	DC and AC Characteristics Graphs and Charts	87
14.0	Packaging Information	95
	The Microchip Web Site	103
	Customer Change Notification Service	103
	Customer Support	103
	Reader Response	104
	Product Identification System	105

TO OUR VALUED CUSTOMERS

It is our intention to provide our valued customers with the best documentation possible to ensure successful use of your Microchip products. To this end, we will continue to improve our publications to better suit your needs. Our publications will be refined and enhanced as new volumes and updates are introduced.

If you have any questions or comments regarding this publication, please contact the Marketing Communications Department via E-mail at docerrors@microchip.com. We welcome your feedback.

Most Current Data Sheet

To obtain the most up-to-date version of this data sheet, please register at our Worldwide Web site at:

<http://www.microchip.com>

You can determine the version of a data sheet by examining its literature number found on the bottom outside corner of any page. The last character of the literature number is the version number, (e.g., DS30000000A is version A of document DS30000000).

Errata

An errata sheet, describing minor operational differences from the data sheet and recommended workarounds, may exist for current devices. As device/documentation issues become known to us, we will publish an errata sheet. The errata will specify the revision of silicon and revision of document to which it applies.

To determine if an errata sheet exists for a particular device, please check with one of the following:

- Microchip's Worldwide Web site; <http://www.microchip.com>
- Your local Microchip sales office (see last page)

When contacting a sales office, please specify which device, revision of silicon and data sheet (include literature number) you are using.

Customer Notification System

Register on our web site at www.microchip.com to receive the most current information on all of our products.

PIC12F529T39A

1.0 GENERAL DESCRIPTION

The PIC12F529T39A device from Microchip Technology is a low-cost, high-performance, 8-bit, fully-static, Flash-based CMOS microcontroller. It employs a RISC architecture with only 34 single-word/single-cycle instructions. All instructions are single cycle except for program branches, which take two cycles. The PIC12F529T39A device delivers performance an order of magnitude higher than its competitors in the same price category. The 12-bit wide instructions are highly symmetrical, resulting in a typical 2:1 code compression over other 8-bit microcontrollers in its class. The easy-to-use and easy to remember instruction set reduces development time significantly.

The PIC12F529T39A product is equipped with special features that reduce system cost and power requirements. The Power-on Reset (POR) and Device Reset Timer (DRT) eliminate the need for external Reset circuitry. There are four oscillator configurations to choose from including INTRC Internal Oscillator mode and the power-saving LP (Low-power) Oscillator mode. Power-Saving Sleep mode, Watchdog Timer and code protection features improve system cost, power and reliability.

The PIC12F529T39A device is available in the cost-effective Flash programmable version, which is suitable for production in any volume. The customer can take full advantage of Microchip's price leadership in Flash programmable microcontrollers, while benefiting from the Flash programmable flexibility.

The PIC12F529T39A product is supported by a full-featured macro assembler, a software simulator, a low-cost development programmer and a full-featured programmer. All the tools are supported on PC and compatible machines.

1.1 Applications

The PIC12F529T39A device fits in applications ranging from personal care appliances and security systems to low-power remote transmitters/receivers. The Flash technology makes customizing application programs (transmitter codes, appliance settings, receiver frequencies, etc.) extremely fast and convenient. The small footprint packages, for through hole or surface mounting, make these microcontrollers perfect for applications with space limitations. Low cost, low power, high performance, ease of use and I/O flexibility make the PIC12F529T39A device very versatile even in areas where no microcontroller use has been considered before (e.g., timer functions, logic and PLDs in larger systems and co-processor applications).

TABLE 1-1: FEATURES AND MEMORY OF PIC12F529T39A

		PIC12F529T39A
Clock	Maximum Frequency of Operation (MHz)	8
Memory	Flash Program Memory	1536
	SRAM Data Memory (bytes)	201
	Flash Data Memory (bytes)	64
Peripherals	Timer Module(s)	TMR0
	Wake-up from Sleep on Pin Change	Yes
Features	I/O Pins	5
	Input Pins	1
	Internal Pull-ups	Yes
	In-Circuit Serial Programming™	Yes
	Number of Instructions	34
	RF Transmitter Frequency Range	310 MHz, 433 MHz, 868 MHz and 915 MHz Bands
	Packages	14-pin TSSOP

2.0 PIC12F529T39A DEVICE VARIETIES

When placing orders, please use the PIC12F529T39A Product Identification System at the back of this data sheet to specify the correct part number. Depending on application and production requirements, the proper device option can be selected using the information in this section.

2.1 Quick-Turn Programming (QTP) Devices

Microchip offers a QTP programming service for factory production orders. This service is made available for users who choose not to program medium-to-high quantity units and whose code patterns have stabilized. The devices are identical to the Flash devices but with all Flash locations and fuse options already programmed by the factory. Certain code and prototype verification procedures do apply before production shipments are available. Please contact your local Microchip Technology sales office for more details.

2.2 Serialized Quick-Turn ProgrammingSM (SQTPSM) Devices

Microchip offers a unique programming service, where a few user-defined locations in each device are programmed with different serial numbers. The serial numbers may be random, pseudo-random or sequential.

Serial programming allows each device to have a unique number, which can serve as an entry code, password or ID number.

PIC12F529T39A

3.0 ARCHITECTURAL OVERVIEW

The high performance of the PIC12F529T39A device can be attributed to a number of architectural features commonly found in RISC microprocessors. To begin with, the PIC12F529T39A device uses a Harvard architecture in which program and data are accessed on separate buses. This improves bandwidth over traditional von Neumann architectures where program and data are fetched on the same bus. Separating program and data memory further allows instructions to be sized differently than the 8-bit wide data word. Instruction opcodes are 12 bits wide, making it possible to have all single-word instructions. A 12-bit wide program memory access bus fetches a 12-bit instruction in a single cycle. A two-stage pipeline overlaps fetch and execution of instructions. Consequently, all instructions (34) execute in a single cycle (500 ns @ 8 MHz, 1 μ s @ 4 MHz) except for program branches.

[Table 3-1](#) below lists memory supported by the PIC12F529T39A device.

TABLE 3-1: PIC12F529T39A MEMORY

Device	Program Memory	Data Memory	
	Flash (words)	SRAM (bytes)	Flash Data (bytes)
PIC12F529T39A	1536	201	64

The PIC12F529T39A device can directly or indirectly address its register files and data memory. All Special Function Registers (SFR), including the PC, are mapped in the data memory. The PIC12F529T39A device has a highly orthogonal (symmetrical) instruction set that makes it possible to carry out any operation, on any register, using any addressing mode. This symmetrical nature and lack of “special optimal situations” make programming with the PIC12F529T39A device simple, yet efficient. In addition, the learning curve is reduced significantly.

The PIC12F529T39A device contains an 8-bit ALU and working register. The ALU is a general purpose arithmetic unit. It performs arithmetic and Boolean functions between data in the working register and any register file.

The ALU is 8-bit wide and capable of addition, subtraction, shift and logical operations. Unless otherwise mentioned, arithmetic operations are two's complement in nature. In two-operand instructions, one operand is typically the W (working) register. The other operand is either a file register or an immediate constant. In single-operand instructions, the operand is either the W register or a file register.

The W register is an 8-bit working register used for ALU operations. It is not an addressable register.

Depending on the instruction executed, the ALU may affect the values of the Carry (C), Digit Carry (DC) and Zero (Z) bits in the STATUS register. The C and DC bits operate as a borrow and digit borrow out bit, respectively, in subtraction. See the `SUBWF` and `ADDWF` instructions for examples.

A simplified block diagram is shown in [Figure 3-1](#), with the corresponding device pins described in [Table 3-2](#).

FIGURE 3-1: PIC12F529T39A ARCHITECTURAL BLOCK DIAGRAM

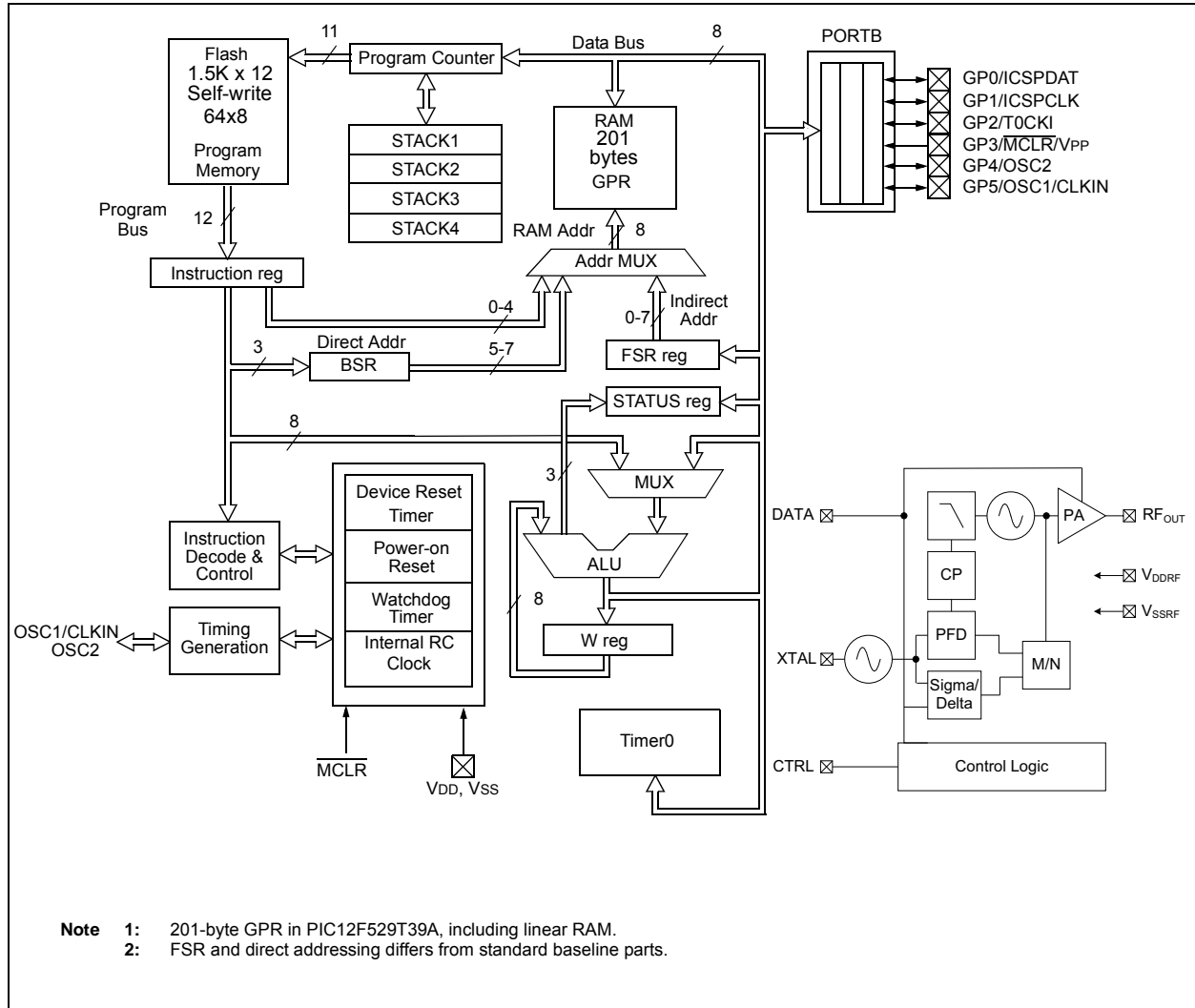

PIC12F529T39A

TABLE 3-2: PIC12F529T39A PINOUT DESCRIPTION

Name	Function	Type	Input Type	Output Type	Description
GP0/ICSPDAT	GP0	I/O	TTL	CMOS	Bidirectional I/O port with weak pull-up.
	ICSPDAT	I/O	ST	CMOS	ICSP™ mode Schmitt Trigger.
GP1/ICSPCLK	GP1	I/O	TTL	CMOS	Bidirectional I/O port with weak pull-up.
	ICSPCLK	I	ST	—	ICSP™ mode Schmitt Trigger.
GP2/T0CKI	GP2	I/O	TTL	CMOS	Bidirectional I/O port.
	T0CKI	I	ST	—	Timer0 clock input.
GP3/MCLR/VPP	GP3	I	TTL	—	Standard TTL input with weak pull-up.
	MCLR	I	ST	—	MCLR input (weak pull-up always enabled in this mode).
	VPP	I	High Voltage	—	Test mode high-voltage pin.
GP4/OSC2	GP4	I/O	TTL	CMOS	Bidirectional I/O port.
	OSC2	O	—	XTAL	XTAL oscillator output pin for microcontroller.
GP5/OSC1/CLKIN	GP5	I/O	TTL	CMOS	Bidirectional I/O port.
	OSC1	I	XTAL	—	XTAL oscillator input pin for microcontroller.
	CLKIN	I	ST	—	EXTRC Schmitt Trigger input.
VDD	VDD	P	Power	—	Positive supply for logic and I/O pins.
VSS	VSS	P	Power	—	Ground reference for logic and I/O pins.
VDDRF	VDDRF	P	Power	—	Positive Power Supply for RF Transmitter.
CTRL	CTRL	I	CMOS	—	Configuration Selection and Configuration Clock.
RFOUT	RFOUT	O	—	RF	Transmitter RF output.
VSSRF	VSSRF	P	Power	—	Ground reference for RF Transmitter.
DATA	DATA	I/O	CMOS	CMOS	Configuration Data and Transmit Data.
XTAL	XTAL	I	XTAL	—	Crystal oscillator input pin for RF Transmitter.

Legend: I = Input, O = Output, I/O = Input/Output, P = Power, — = Not Used, TTL = TTL input, ST = Schmitt Trigger input, AN = Analog Voltage

3.1 Clocking Scheme/Instruction Cycle

The clock input (OSC1/CLKIN pin) is internally divided by four to generate four non-overlapping quadrature clocks, namely Q1, Q2, Q3 and Q4. Internally, the PC is incremented every Q1 and the instruction is fetched from program memory and latched into the instruction register in Q4. It is decoded and executed during the following Q1 through Q4. The clocks and instruction execution flow is shown in Figure 3-2 and Example 3-1.

3.2 Instruction Flow/Pipelining

An instruction cycle consists of four Q cycles (Q1, Q2, Q3 and Q4). The instruction fetch and execute are pipelined such that fetch takes one instruction cycle, while decode and execute take another instruction cycle. However, due to the pipelining, each instruction effectively executes in one cycle. If an instruction causes the PC to change (e.g., GOTO), then two cycles are required to complete the instruction (Example 3-1).

A fetch cycle begins with the PC incrementing in Q1.

In the execution cycle, the fetched instruction is latched into the Instruction Register (IR) in cycle Q1. This instruction is then decoded and executed during the Q2, Q3 and Q4 cycles. Data memory is read during Q2 (operand read) and written during Q4 (destination write).

FIGURE 3-2: CLOCK/INSTRUCTION CYCLE

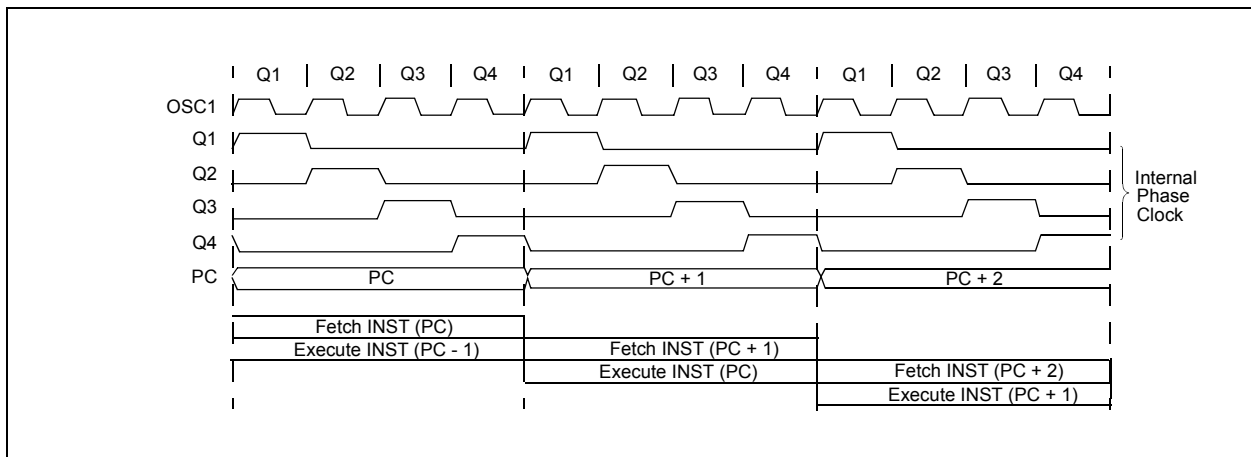

EXAMPLE 3-1: INSTRUCTION PIPELINE FLOW

1. MOVLW 03H
2. MOVWF GPIO
3. CALL SUB_1
4. BSF GPIO, 1

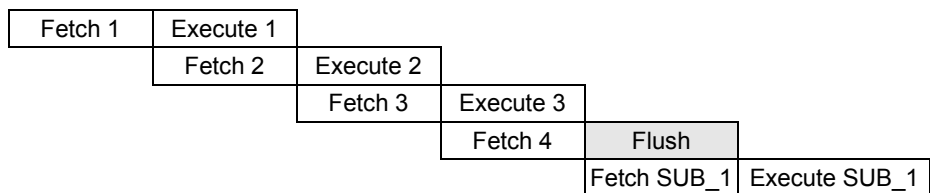

All instructions are single cycle, except for any program branches. These take two cycles, since the fetch instruction is “flushed” from the pipeline, while the new instruction is being fetched and then executed.

PIC12F529T39A

4.0 MEMORY ORGANIZATION

The PIC12F529T39A memory is organized into program memory and data memory (SRAM). The self-writable portion of the program memory called Flash data memory, is located at addresses 600h-63Fh. As the device has more than 512 bytes of program memory, a paging scheme is used. Program memory pages are accessed using STATUS register bit, PA0. For the PIC12F529T39A, with data memory register files of more than 32 registers, a banking scheme is used. Data memory banks are accessed using the File Select Register (FSR).

4.1 Program Memory Organization for the PIC12F529T39A

The PIC12F529T39A device has an 11-bit Program Counter (PC) capable of addressing a 2K x 12 program memory space.

Only the first 1.5K x 12 (0000h-05FFh) are physically implemented (see Figure 4-1). Accessing a location above these boundaries will cause a wrap-around within the 1.5K x 12 space. The effective Reset vector is a 0000h (see Figure 4-1). Location 05FFh contains the internal clock oscillator calibration value. This value should never be overwritten.

FIGURE 4-1: MEMORY MAP

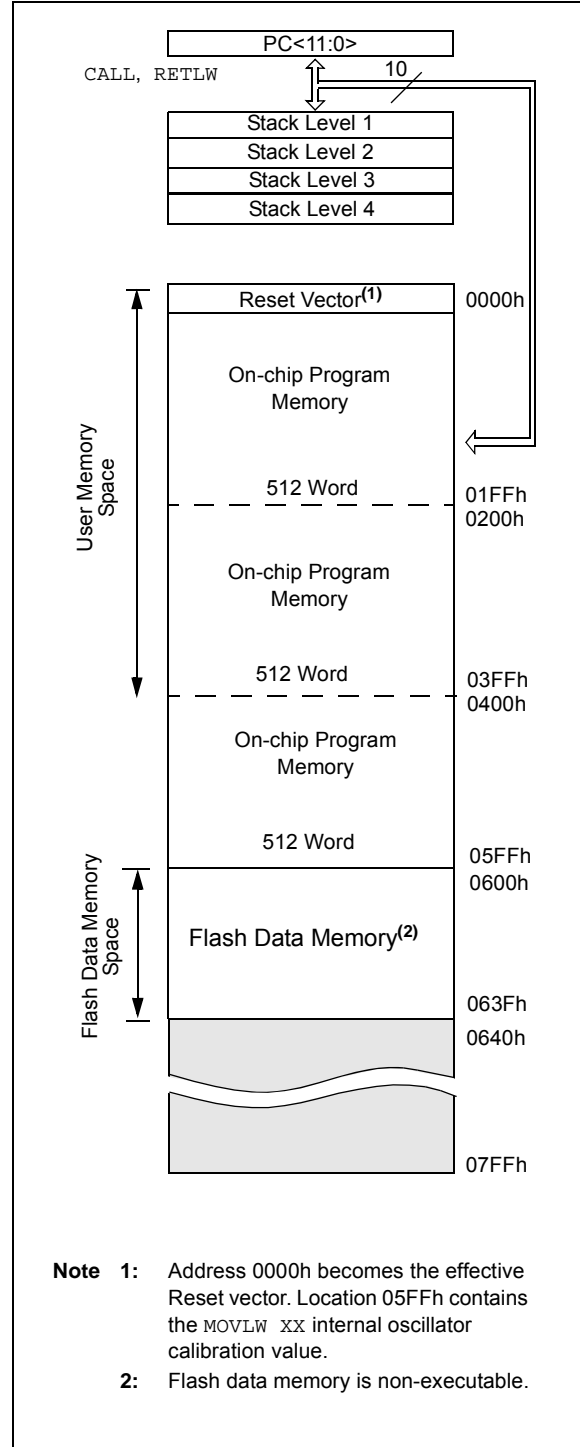

PIC12F529T39A

4.2.2 SPECIAL FUNCTION REGISTERS

The Special Function Registers (SFRs) are registers used by the CPU and peripheral functions to control the operation of the device (Table 4-1).

The Special Function Registers can be classified into two sets. The Special Function Registers associated with the “core” functions are described in this section. Those related to the operation of the peripheral features are described in the section for each peripheral feature.

4.2.3 LINEAR RAM

The last four banks, addresses 0x80 to 0xFF, are general purpose RAM registers, unbroken by SFRs. This region is ideal for indirect access using the FSR and INDF registers.

Note: Unlike other baseline devices, the FSR register does not contain bank bits and, therefore, does not affect direct addressing schemes. The FSR/INDF registers have full access to RAM.

TABLE 4-1: SPECIAL FUNCTION REGISTER SUMMARY

Addr	Name	Bit 7	Bit 6	Bit 5	Bit 4	Bit 3	Bit 2	Bit 1	Bit 0	Value on Power-on Reset
N/A	TRIS	—	—	TRISGPIO5	TRISGPIO4	TRISGPIO3	TRISGPIO2	TRISGPIO1	TRISGPIO0	--11 1111
N/A	OPTION	Contains Control Bits to Configure Timer0 and Timer0/WDT Prescaler								1111 1111
N/A	BSR	—	—	—	—	—	BSR<2:0>			---- -000
00h	INDF	Uses Contents of FSR to Address Data Memory (not a physical register)								xxxx xxxx
01h	TMR0	Timer0 Module Register								xxxx xxxx
02h ⁽¹⁾	PCL	Low Order 8 bits of PC								1111 1111
03h	STATUS	GPWUF	PA1	PA0	\overline{TO}	\overline{PD}	Z	DC	C	0001 1xxxx
04h	FSR	Indirect Data Memory Address Pointer								110x xxxx
05h	OSCCAL	CAL6	CAL5	CAL4	CAL3	CAL2	CAL1	CAL0	—	1111 111-
06h	GPIO	—	—	GP5	GP4	GP3	GP2	GP1	GP0	--xx xxxx
21h	EECON	—	—	—	FREE	WRERR	WREN	WR	RD	---0 x000
25h	EEDATA	EEDATA7	EEDA-TA6	EEDATA5	EEDATA4	EEDATA3	EEDATA2	EEDATA1	EEDATA0	xxxx xxxx
26h	EEADR	—	—	EEADR5	EEADR4	EEADR3	EEADR2	EEADR1	EEADR0	--xx xxxx

Legend: x = unknown, u = unchanged, — = unimplemented, read as '0' (if applicable). Shaded cells = unimplemented or unused
Note 1: The upper byte of the Program Counter is not directly accessible. See Section 4.6 “Program Counter” for an explanation of how to access these bits.

4.3 STATUS Register

This register contains the arithmetic status of the ALU, the Reset status and the page preselect bit.

The STATUS register can be the destination for any instruction, as with any other register. If the STATUS register is the destination for an instruction that affects the Z, DC or C bits, then the write to these three bits is disabled. These bits are set or cleared according to the device logic. Furthermore, the \overline{TO} and \overline{PD} bits are not writable. Therefore, the result of an instruction with the STATUS register as destination may be different than intended.

For example, `CLRF STATUS`, will clear the upper three bits and set the Z bit. This leaves the STATUS register as '000u u1uu' (where u = unchanged).

Therefore, it is recommended that only `BCF`, `BSF` and `MOVWF` instructions be used to alter the STATUS register. These instructions do not affect the Z, DC or C bits from the STATUS register. For other instructions which do affect Status bits, see [Section 10.0 "Instruction Set Summary"](#).

REGISTER 4-1: STATUS: STATUS REGISTER

R/W-0	R/W-0	R/W-0	R-1	R-1	R/W-x	R/W-x	R/W-x
GPWUF	PA1	PA0	\overline{TO}	\overline{PD}	Z	DC	C
bit 7							bit 0

Legend:

R = Readable bit	W = Writable bit	U = Unimplemented bit, read as '0'
-n = Value at POR	'1' = Bit is set	'0' = Bit is cleared
		x = Bit is unknown

bit 7	GPWUF: Wake-up From Sleep on Pin Change bit 1 = Reset due to wake-up from Sleep on pin change 0 = After power-up or other Reset
bit 6-5	PA<1:0>: Program Page Preselect bits ⁽¹⁾ 00 = Page 0 (000h-1FFh) 01 = Page 1 (200h-3FFh) 10 = Page 2 (400h-5FFh) 11 = Reserved. Do not use.
bit 4	\overline{TO}: Time-Out bit 1 = After power-up, <code>CLRWDT</code> instruction, or <code>SLEEP</code> instruction 0 = A WDT time-out occurred
bit 3	\overline{PD}: Power-Down bit 1 = After power-up or by the <code>CLRWDT</code> instruction 0 = By execution of the <code>SLEEP</code> instruction
bit 2	Z: Zero bit 1 = The result of an arithmetic or logic operation is zero 0 = The result of an arithmetic or logic operation is not zero
bit 1	DC: Digit Carry/Borrow bit (for <code>ADDWF</code> and <code>SUBWF</code> instructions) ADDWF : 1 = A carry from the 4th low-order bit of the result occurred 0 = A carry from the 4th low-order bit of the result did not occur SUBWF : 1 = A borrow from the 4th low-order bit of the result did not occur 0 = A borrow from the 4th low-order bit of the result occurred
bit 0	C: Carry/Borrow bit (for <code>ADDWF</code> , <code>SUBWF</code> and <code>RRF</code> , <code>RLF</code> instructions) ADDWF : SUBWF : RRF or RLF : 1 = A carry occurred 1 = A borrow did not occur Load bit with LSb or MSb, respectively 0 = A carry did not occur 0 = A borrow occurred

Note 1: Do not set both PA0 and PA1.

PIC12F529T39A

4.4 OPTION Register

The OPTION register is a 8-bit wide, write-only register, which contains various control bits to configure the Timer0/WDT prescaler and Timer0.

By executing the OPTION instruction, the contents of the W register will be transferred to the OPTION register. A Reset sets the OPTION<7:0> bits.

Note: If the T0SC bit is set to '1', it will override the TRIS function on the T0CKI pin.

REGISTER 4-2: OPTION: OPTION REGISTER

W-1	W-1	W-1	W-1	W-1	W-1	W-1	W-1
GPWU	GPPU	T0CS	T0SE	PSA	PS<2:0>		
bit 7							bit 0

Legend:

R = Readable bit	W = Writable bit	x = Bit is unknown
-n = Value at POR	'1' = Bit is set	'0' = Bit is cleared

- bit 7 **GPWU:** Enable Wake-up On Pin Change bit
1 = Disabled
0 = Enabled
- bit 6 **GPPU:** Enable Weak Pull-Ups bit
1 = Disabled
0 = Enabled
- bit 5 **T0CS:** Timer0 Clock Source Select bit
1 = Transition on T0CKI pin
0 = Internal instruction cycle clock (CLKOUT)
- bit 4 **T0SE:** Timer0 Source Edge Select bit
1 = Increment on high-to-low transition on T0CKI pin
0 = Increment on low-to-high transition on T0CKI pin
- bit 3 **PSA:** Prescaler Assignment bit
1 = Prescaler assigned to the WDT
0 = Prescaler assigned to Timer0
- bit 2-0 **PS<2:0>:** Prescaler Rate Select bits

Bit Value	Timer0 Rate	WDT Rate
000	1 : 2	1 : 1
001	1 : 4	1 : 2
010	1 : 8	1 : 4
011	1 : 16	1 : 8
100	1 : 32	1 : 16
101	1 : 64	1 : 32
110	1 : 128	1 : 64
111	1 : 256	1 : 128

4.5 OSCCAL Register

The Oscillator Calibration (OSCCAL) register is used to calibrate the 8 MHz internal oscillator macro. It contains seven bits of calibration that uses a two's complement scheme for controlling the oscillator speed. See [Register 4-3](#) for details.

REGISTER 4-3: OSCCAL: OSCILLATOR CALIBRATION REGISTER

R/W-1	R/W-1	R/W-1	R/W-1	R/W-1	R/W-1	R/W-1	U-0
CAL<6:0>							—
bit 7							bit 0

Legend:

R = Readable bit	W = Writable bit	U = Unimplemented bit, read as '0'
-n = Value at POR	'1' = Bit is set	'0' = Bit is cleared x = Bit is unknown

bit 7-1 **CAL<6:0>**: Oscillator Calibration bits
 0111111 = Maximum frequency
 •
 •
 •
 0000001
 0000000 = Center frequency
 1111111
 •
 •
 •
 1000000 = Minimum frequency

bit 0 **Unimplemented**: Read as '0'

PIC12F529T39A

4.6 Program Counter

As a program instruction is executed, the Program Counter (PC) will contain the address of the next program instruction to be executed. The PC value is increased by one every instruction cycle, unless an instruction changes the PC.

For a GOTO instruction, bits <8:0> of the PC are provided by the GOTO instruction word. The Program Counter (PCL) is mapped to PC<7:0>. Bits 5 and 6 of the STATUS register provide page information to bits 9 and 10 of the PC. (Figure 4-3).

For a CALL instruction, or any instruction where the PCL is the destination, bits <7:0> of the PC again are provided by the instruction word. However, PC<8> does not come from the instruction word, but is always cleared (Figure 4-3).

Instructions where the PCL is the destination, or modify PCL instructions, include MOVWF PCL, ADDWF PCL and BSF PCL, 5.

Note: Because PC<8> is cleared in the CALL instruction or any modify PCL instruction, all subroutine calls or computed jumps are limited to the first 256 locations of any program memory page (512 words long).

4.6.1 EFFECTS OF RESET

The PC is set upon a Reset, which means that the PC addresses the last location in the last page (i.e., the oscillator calibration instruction). After executing MOVLW XX, the PC will roll over to location 00h and begin executing user code.

The STATUS register page preselect bits are cleared upon a Reset, which means that page 0 is pre-selected.

Therefore, upon a Reset, a GOTO instruction will automatically cause the program to jump to page 0 until the value of the page bits is altered.

4.7 Stack

The PIC12F529T39A device has a four-deep, 12-bit wide hardware PUSH/POP stack.

A CALL instruction will PUSH the current value of Stack 1 into Stack 2 and then PUSH the current PC value, incremented by one, into Stack Level 1. If more than four sequential CALLS are executed, only the most recent four return addresses are stored.

A RETLW instruction will POP the contents of Stack Level 1 into the PC and then copy Stack Level 2 contents into Stack Level 1. If more than four sequential RETLWs are executed, the stack will be filled with the address previously stored in Stack Level 2. Note that the W register will be loaded with the literal value specified in the instruction. This is particularly useful for the implementation of data look-up tables within the program memory.

Note 1: There are no Status bits to indicate Stack Overflow or Stack Underflow conditions.
2: There are no instruction mnemonics called PUSH or POP. These are actions that occur from the execution of the CALL and RETLW instructions.

FIGURE 4-3: LOADING OF PC BRANCH INSTRUCTIONS

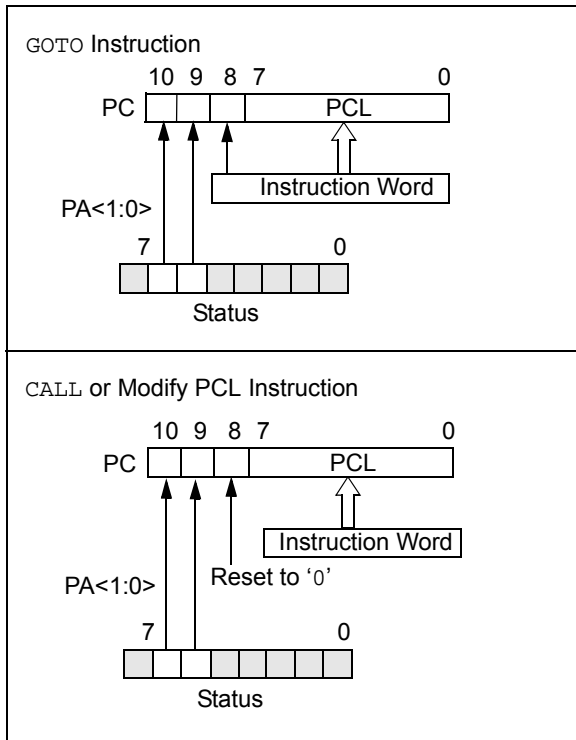

4.8 Indirect Data Addressing: INDF and FSR Registers

The INDF register is not a physical register. Addressing INDF actually addresses the register whose address is contained in the FSR register (FSR is a *pointer*). This is indirect addressing.

Reading INDF itself indirectly (FSR = 0) will produce 00h. Writing to the INDF register indirectly results in a no-operation (although Status bits may be affected).

The FSR is an 8-bit wide register. It is used in conjunction with the INDF register to indirectly address the data memory area.

EXAMPLE 4-1: HOW TO CLEAR RAM USING INDIRECT ADDRESSING

```

MOV LW 0x10 ;initialize pointer
MOV WF FSR ;to RAM
NEXT   CLR F INDF ;clear INDF
        ;register
        INC F FSR,F ;inc pointer
        BT FSC FSR,4 ;all done?
        GOTO NEXT ;NO, clear next
CONTINUE
        : ;YES, continue
        :
    
```

FIGURE 4-4: DIRECT/INDIRECT ADDRESSING

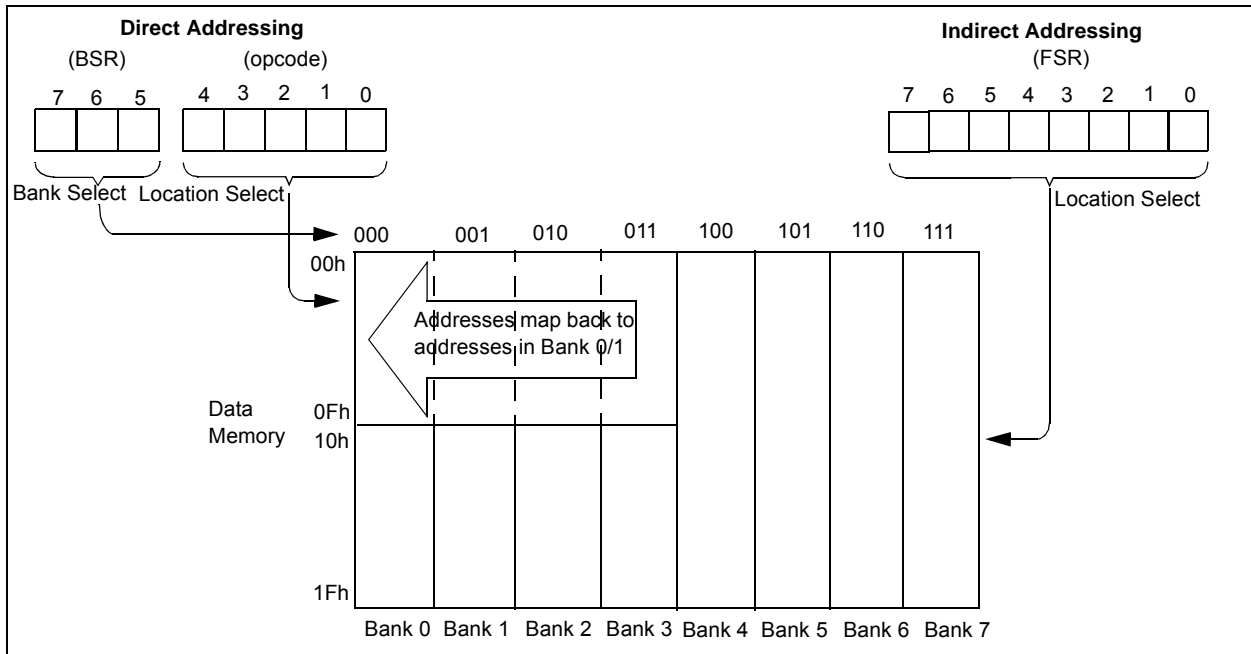

4.9 Direct Data Addressing

Banking when using direct addressing methods is accomplished using the `MOVLB` instruction to write to the BSR. The BSR, like the `OPTION` register, is not mapped to user-accessible memory. The value in BSR has no effect on indirect addressed operations.

5.0 FLASH DATA MEMORY CONTROL

The Flash data memory is readable and writable during normal operation (full VDD range). This memory is not directly mapped in the register file space. Instead, it is indirectly addressed through the Special Function Registers (SFRs).

5.1 Reading Flash Data Memory

To read a Flash data memory location the user must:

- Write the EEADR register
- Set the RD bit of the EECON register

The value written to the EEADR register determines which Flash data memory location is read. Setting the RD bit of the EECON register initiates the read. Data from the Flash data memory read is available in the EEDATA register immediately. The EEDATA register will hold this value until another read is initiated or it is modified by a write operation. Program execution is suspended while the read cycle is in progress. Execution will continue with the instruction following the one that sets the WR bit. See [Example 5-1](#) for sample code.

EXAMPLE 5-1: READING FROM FLASH DATA MEMORY

```
BANKSEL EEADR      ;
MOVWF DATA_EE_ADDR, W ;
MOVWF EEADR        ;Data Memory
                   ;Address to read

BANKSEL EECON1     ;

BSF EECON, RD      ;EE Read
MOVWF EEDATA, W    ;W = EEDATA
```

Note: Only a BSF command will work to enable the Flash data memory read documented in [Example 5-1](#). No other sequence of commands will work, no exceptions.

5.2 Writing and Erasing Flash Data Memory

Flash data memory is erased one row at a time and written one byte at a time. The 64-byte array is made up of eight rows. A row contains eight sequential bytes. Row boundaries exist every eight bytes.

Generally, the procedure to write a byte of data to Flash data memory is:

1. Identify the row containing the address where the byte will be written.
2. If there is other information in that row that must be saved, copy those bytes from Flash data memory to RAM.

3. Perform a row erase of the row of interest.
4. Write the new byte of data and any saved bytes back to the appropriate addresses in Flash data memory.

To prevent accidental corruption of the Flash data memory, an unlock sequence is required to initiate a write or erase cycle. This sequence requires that the bit set instructions used to configure the EECON register happen exactly as shown in [Example 5-2](#) and [Example 5-3](#), depending on the operation requested.

5.2.1 ERASING FLASH DATA MEMORY

A row must be manually erased before writing new data. The following sequence must be performed for a single row erase.

1. Load EEADR with an address in the row to be erased.
2. Set the FREE bit to enable the erase.
3. Set the WREN bit to enable write access to the array.
4. Set the WR bit to initiate the erase cycle.

If the WREN bit is not set in the instruction cycle after the FREE bit is set, the FREE bit will be cleared in hardware.

If the WR bit is not set in the instruction cycle after the WREN bit is set, the WREN bit will be cleared in hardware.

Sample code that follows this procedure is included in [Example 5-2](#).

Program execution is suspended while the erase cycle is in progress. Execution will continue with the instruction following the one that sets the WR bit.

EXAMPLE 5-2: ERASING A FLASH DATA MEMORY ROW

```
BANKSEL EEADR
MOVLW EE_ADR_ERASE ; LOAD ADDRESS OF ROW TO
                   ; ERASE
MOVWF EEADR ;
BSF EECON, FREE ; SELECT ERASE
BSF EECON, WREN ; ENABLE WRITES
BSF EECON, WR ; INITIATE ERASE
```

Note 1: The FREE bit may be set by any command normally used by the core. However, the WREN and WR bits can only be set using a series of BSF commands, as documented in [Example 5-1](#). No other sequence of commands will work, no exceptions.

2: Bits <5:3> of the EEADR register indicate which row is to be erased.

5.2.2 WRITING TO FLASH DATA MEMORY

Once a cell is erased, new data can be written. Program execution is suspended during the write cycle. The following sequence must be performed for a single byte write.

1. Load EEADR with the address.
2. Load EEDATA with the data to write.
3. Set the WREN bit to enable write access to the array.
4. Set the WR bit to initiate the erase cycle.

If the WR bit is not set in the instruction cycle after the WREN bit is set, the WREN bit will be cleared in hardware.

Sample code that follows this procedure is included in [Example 5-3](#).

EXAMPLE 5-3: WRITING A FLASH DATA MEMORY ROW

```
BANKSEL    EEADR
MOVLW     EE_ADR_WRITE    ; LOAD ADDRESS
MOVWF     EEADR           ;
MOVLW     EE_DATA_TO_WRITE ; LOAD DATA
MOVWF     EEDATA          ; INTO EEDATA REGISTER
BSF       EECON,WREN      ; ENABLE WRITES
BSF       EECON,WR        ; INITIATE ERASE
```

Note 1: Only a series of BSF commands will work to enable the memory write sequence documented in [Example 5-2](#). No other sequence of commands will work, no exceptions.

- 2: For reads, erases and writes to the Flash data memory, there is no need to insert a NOP into the user code as is done on mid-range devices. The instruction immediately following the “BSF EECON,WR/RD” will be fetched and executed properly.

5.3 Write Verify

Depending on the application, good programming practice may dictate that data written to the Flash data memory be verified. [Example 5-4](#) is an example of a write verify.

EXAMPLE 5-4: WRITE VERIFY OF DATA EEPROM

```
MOVF     EEDATA, W        ;EEDATA has not changed
                                ;from previous write
BSF      EECON, RD        ;Read the value written
XORWF    EEDATA, W        ;
BTFSS    STATUS, Z        ;Is data the same
GOTO     WRITE_ERR        ;No, handle error
                                ;Yes, continue
```

5.4 Code Protection

Code protection does not prevent the CPU from performing read or write operations on the Flash data memory. Refer to the code protection chapter for more information.

PIC12F529T39A

NOTES:

6.0 I/O PORT

As with any other register, the I/O register(s) can be written and read under program control. However, read instructions (e.g., `MOVF PORTB, W`) always read the I/O pins independent of the pin's Input/Output modes. On Reset, all I/O ports are defined as input (inputs are at high-impedance) since the I/O control registers are all set.

6.1 GPIO

GPIO is an 8-bit I/O register. Only the low-order six bits are used (GP<5:0>). Bits 7 and 6 are unimplemented and read as '0's. Please note that GP3 is an input-only pin. The Configuration Word can set several I/O's to alternate functions. When acting as alternate functions, the pins will read as '0' during a port read. Pins GP0, GP1, and GP3 can be configured with weak pull-ups and also for wake-up on change. The wake-up on change and weak pull-up functions are not pin selectable. If GP3/MCLR is configured as MCLR, weak pull-up is always on and wake-up on change for this pin is not enabled.

6.2 TRIS Registers

The Output Driver Control registers are loaded with the contents of the W register by executing the `TRIS F` instruction. A '1' from a TRISGPIO register bit puts the corresponding output driver in a high-impedance (Input) mode. A '0' puts the contents of the output data latch on the selected pins, enabling the output buffer.

The TRISGPIO register is "write-only". Bits <5:0> are set (output drivers disabled) upon Reset.

Note: If the T0CS bit is set to '1', it will override the TRISGPIO function on the T0CKI pin.

TABLE 6-1: WEAK PULL-UP ENABLED PINS

Pin	WPU	WU
GP0	Y	Y
GP1	Y	Y
GP2	N	N
GP3	Y ⁽¹⁾	Y
GP4	N	N
GP5	N	N

Note 1: When `MCLRE = 1`, the weak pull-up on GP3/MCLR is always enabled.

2: WPU = Weak pull-up; WU = Wake-up.

PIC12F529T39A

REGISTER 6-1: GPIO: GPIO REGISTER

U-0	U-0	R/W-x	R/W-x	R/W-x	R/W-x	R/W-x	R/W-x
—	—	GP5	GP4	GP3	GP2	GP1	GP0
bit 7							bit 0

Legend:

R = Readable bit W = Writable bit U = Unimplemented bit, read as '0'
 -n = Value at POR '1' = Bit is set '0' = Bit is cleared x = Bit is unknown

bit 7-6 **Unimplemented:** Read as '0'

bit 5-0 **GP<5:0>:** GPIO I/O Pin bits
 1 = GPIO pin is >V_{IH} min.
 0 = GPIO pin is <V_{IL} max.

REGISTER 6-2: TRISGPIO: TRI-STATE GPIO REGISTER

U-0	U-0	W-1	W-1	W-1	W-1	W-1	W-1
—	—	TRISGPIO5	TRISGPIO4	TRISGPIO3	TRISGPIO2	TRISGPIO1	TRISGPIO0
bit 7							bit 0

Legend:

R = Readable bit W = Writable bit U = Unimplemented bit, read as '0'
 -n = Value at POR '1' = Bit is set '0' = Bit is cleared x = Bit is unknown

bit 7-6 **Unimplemented:** Read as '0'

bit 5-0 **TRISGPIO<5:0>:** GPIO Tri-State Control bits
 1 = GPIO pin configured as an input (tri-stated)
 0 = GPIO pin configured as an output

6.3 I/O Interfacing

The equivalent circuit for an I/O port pin is shown in Figure 6-1. All port pins, except GP3 which is input only, may be used for both input and output operations. For input operations, these ports are non-latching. Any input must be present until read by an input instruction (e.g., `MOVF GPIO, W`). The outputs are latched and remain unchanged until the output latch is rewritten. To use a port pin as output, the corresponding direction control bit in TRISGPIO must be cleared (= 0). For use as an input, the corresponding TRISGPIO bit must be set. Any I/O pin (except GP3) can be programmed individually as input or output.

FIGURE 6-1: PIC12F529T39A EQUIVALENT CIRCUIT FOR I/O PINS – GP0/GP1

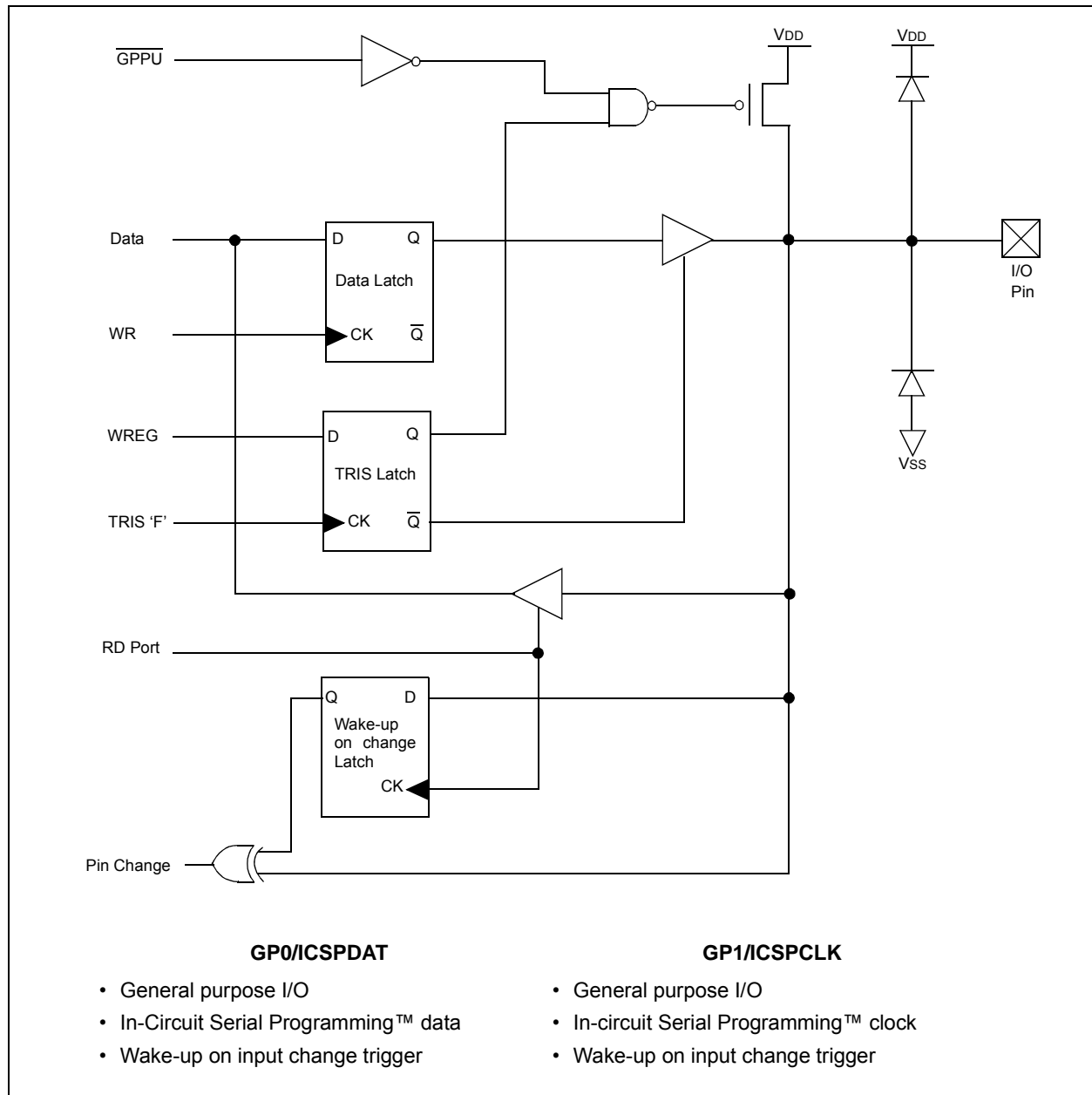

PIC12F529T39A

FIGURE 6-2: GP2/TOCK1

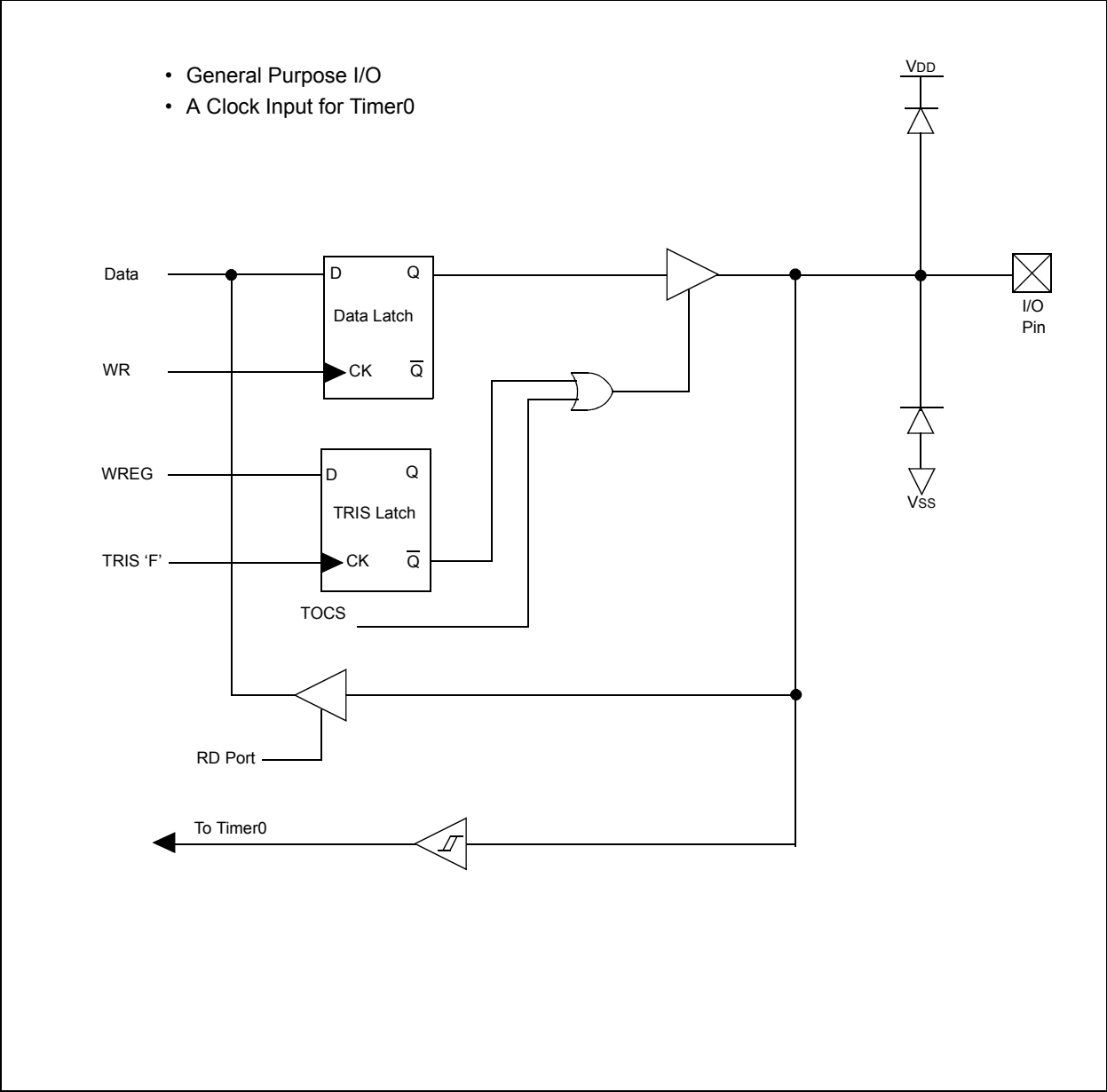
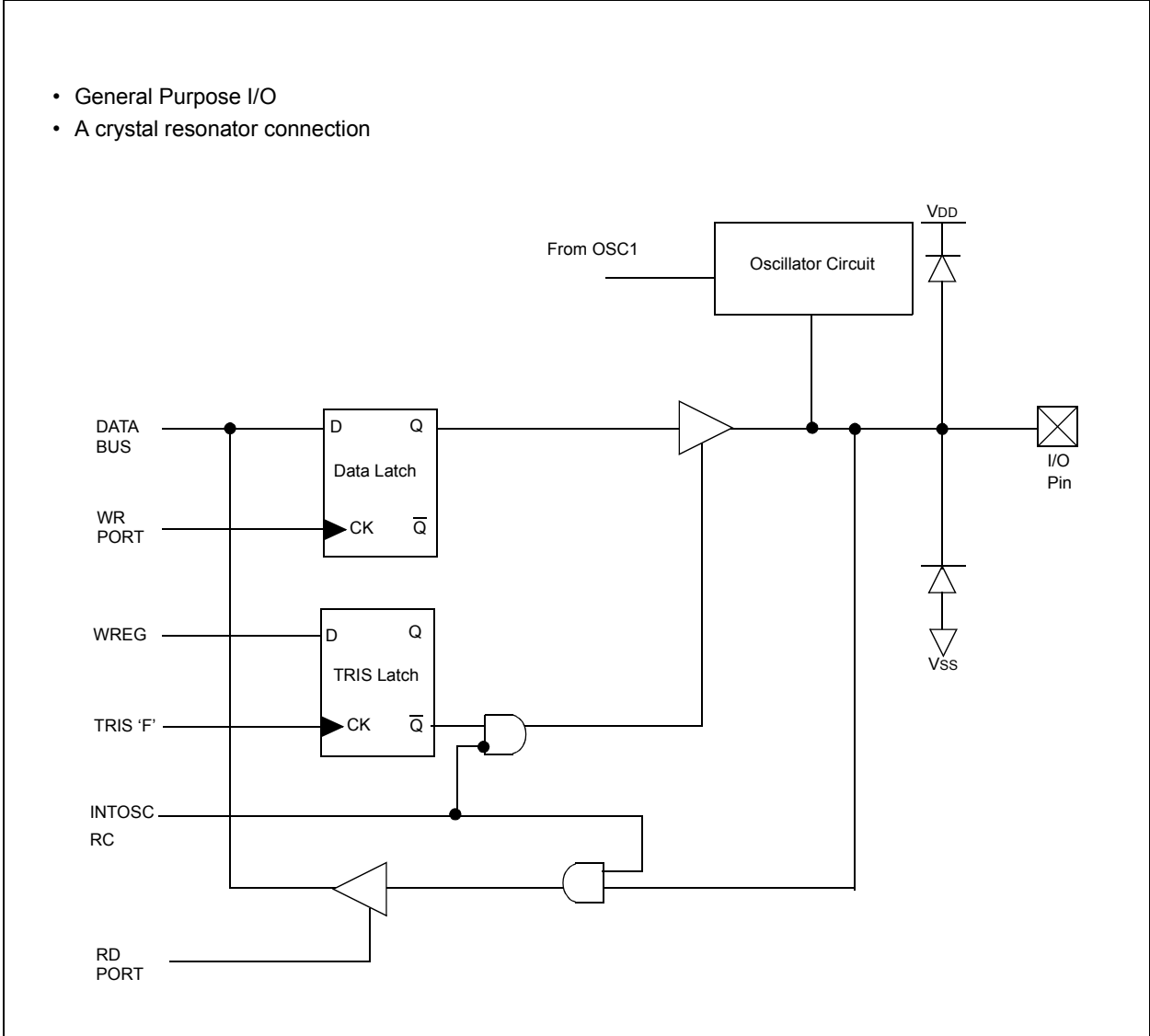

FIGURE 6-3: GP4/OSC2



PIC12F529T39A

FIGURE 6-4: GP5/OSC1/CLKIN

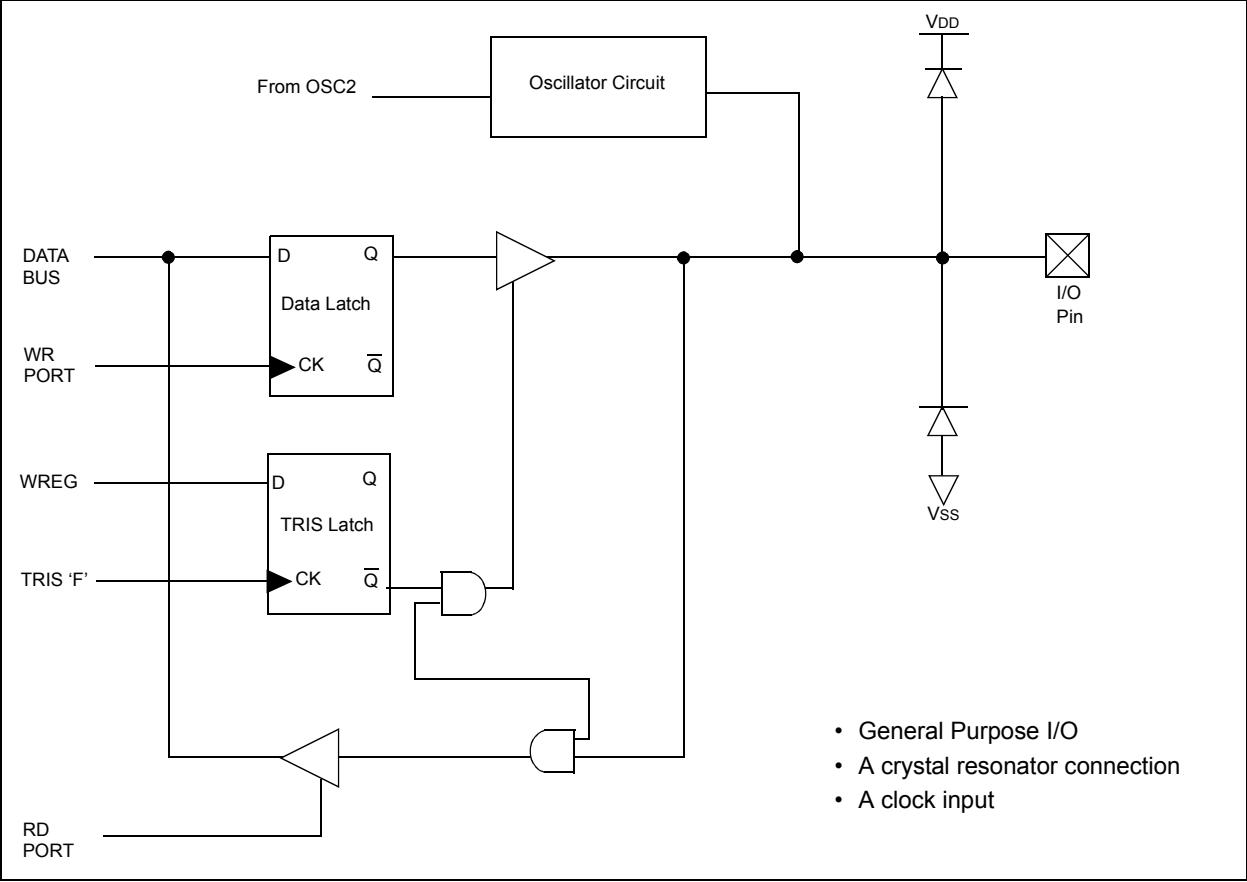

FIGURE 6-5: GP3 (WITH WEAK PULL-UP AND WAKE-UP ON CHANGE)

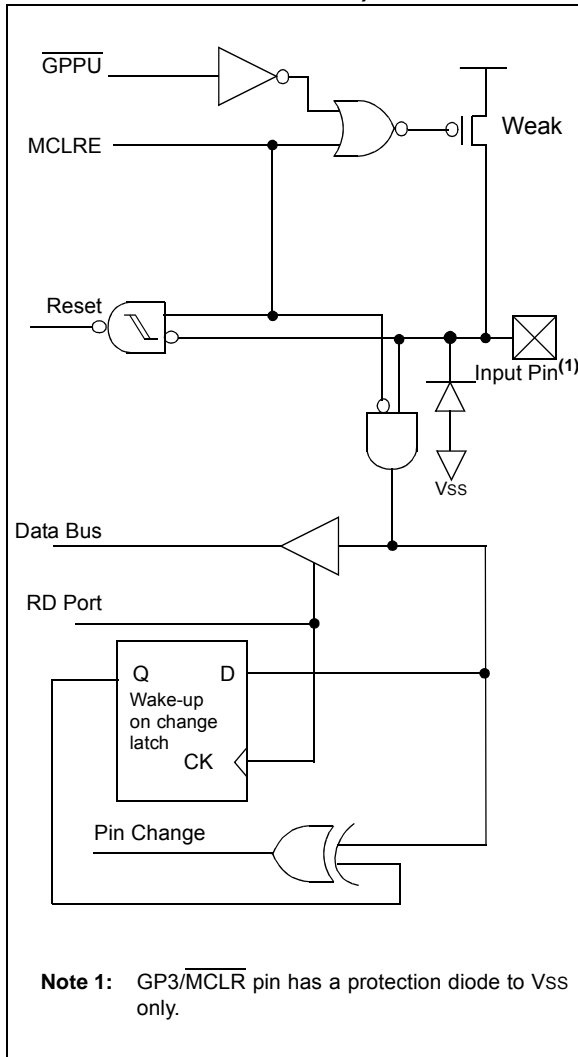

TABLE 6-2: SUMMARY OF PORT REGISTERS

Name	Bit 7	Bit 6	Bit 5	Bit 4	Bit 3	Bit 2	Bit 1	Bit 0	Register on Page
GPIO	—	—	GP5	GP4	GP3	GP2	GP1	GP0	22
TRISGPIO	—	—	TRISGPIO5	TRISGPIO4	TRISGPIO3	TRISGPIO2	TRISGPIO1	TRISGPIO0	22
STATUS	GPWUF	PA1	PA0	\overline{TO}	\overline{PD}	Z	DC	C	13
OPTION	\overline{GPWU}	\overline{GPPU}	T0CS	T0SE	PSA	PS2	PS1	PS0	14

Legend: x = unknown, u = unchanged, — = unimplemented, read as '0', Shaded cells = unimplemented, read as '0', α = depends on the condition

PIC12F529T39A

6.4 I/O Programming Considerations

6.4.1 BIDIRECTIONAL I/O PORTS

Some instructions operate internally as read followed by write operations. The BCF and BSF instructions, for example, read the entire port into the CPU, execute the bit operation and re-write the result. Caution must be used when these instructions are applied to a port where one or more pins are used as input/outputs. For example, a BSF operation on bit 5 of GPIO will cause all eight bits of GPIO to be read into the CPU, bit 5 to be set and the GPIO value to be written to the output latches. If another bit of GPIO is used as a bidirectional I/O pin (say bit 0) and it is defined as an input at this time, the input signal present on the pin itself would be read into the CPU and rewritten to the data latch of this particular pin, overwriting the previous content. As long as the pin stays in the Input mode, no problem occurs. However, if bit 0 is switched into Output mode later on, the content of the data latch may now be unknown.

Example 6-1 shows the effect of two sequential Read-Modify-Write instructions (e.g., BCF, BSF, etc.) on an I/O port.

A pin actively outputting a high or a low should not be driven from external devices at the same time in order to change the level on this pin (“wired OR”, “wired AND”). The resulting high output currents may damage the chip.

EXAMPLE 6-1: READ-MODIFY-WRITE INSTRUCTIONS ON AN I/O PORT

```

;Initial GPIO Settings
;GPIO<5:3> Inputs
;GPIO<2:0> Outputs
;
;
;           GPIO latch   GPIO pins
;           -----   -----
BCF   GPIO, 5 ;--01 -ppp  --11 pppp
BCF   GPIO, 4 ;--10 -ppp  --11 pppp
MOVLW 007h;
TRIS  GPIO   ;--10 -ppp  --11 pppp
;

```

Note 1: The user may have expected the pin values to be ‘--00 pppp’. The 2nd BCF caused GP5 to be latched as the pin value (High).

6.4.2 SUCCESSIVE OPERATIONS ON I/O PORTS

The actual write to an I/O port happens at the end of an instruction cycle, whereas for reading, the data must be valid at the beginning of the instruction cycle (Figure 6-6). Therefore, care must be exercised if a write, followed by a read operation, is carried out on the same I/O port. The sequence of instructions should allow the pin voltage to stabilize (load dependent) before the next instruction causes that file to be read into the CPU. Otherwise, the previous state of that pin may be read into the CPU rather than the new state. When in doubt, it is better to separate these instructions with a NOP or another instruction not accessing this I/O port.

FIGURE 6-6: SUCCESSIVE I/O OPERATION

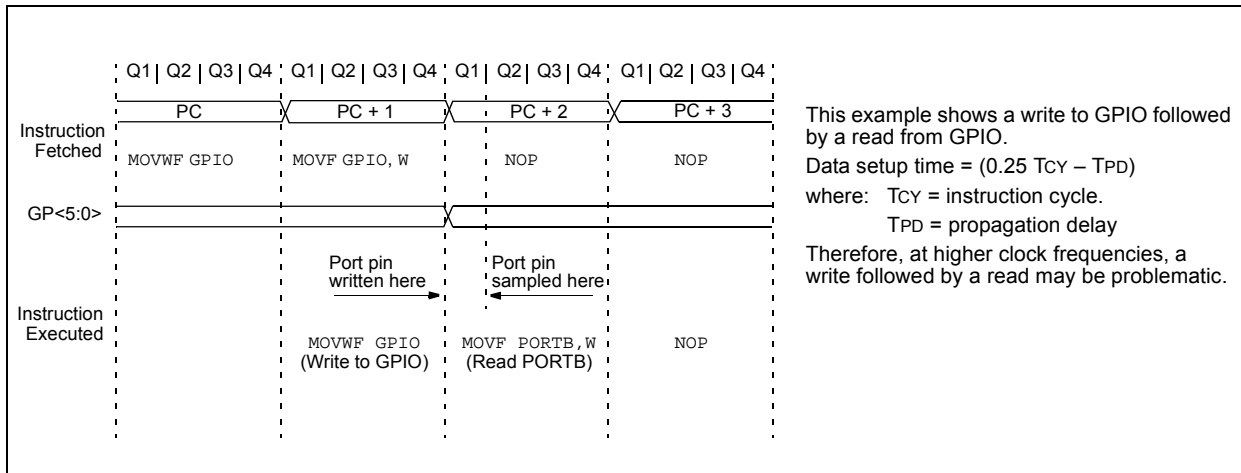

7.0 TIMER0 MODULE AND TMR0 REGISTER

The Timer0 module has the following features:

- 8-bit timer/counter register, TMR0
- Readable and writable
- 8-bit software programmable prescaler
- Internal or external clock select:
 - Edge select for external clock

Figure 7-1 is a simplified block diagram of the Timer0 module.

Timer mode is selected by clearing the T0CS bit (OPTION<5>). In Timer mode, the Timer0 module will increment every instruction cycle (without prescaler). If the TMR0 register is written, the increment is inhibited for the following two cycles (Figure 7-2 and Figure 7-3). The user can work around this by writing an adjusted value to the TMR0 register.

Counter mode is selected by setting the T0CS bit (OPTION<5>). In this mode, Timer0 will increment either on every rising or falling edge of pin T0CKI. The T0SE bit (OPTION<4>) determines the source edge. Clearing the T0SE bit selects the rising edge. Restrictions on the external clock input are discussed in detail in Section 7.1 “Using Timer0 with an External Clock”.

The prescaler may be used by either the Timer0 module or the Watchdog Timer, but not both. The prescaler assignment is controlled in software by the control bit, PSA (OPTION<3>). Clearing the PSA bit will assign the prescaler to Timer0. The prescaler is not readable or writable. When the prescaler is assigned to the Timer0 module, prescale values of 1:2, 1:4, ..., 1:256 are selectable. Section 7.2 “Prescaler” details the operation of the prescaler.

A summary of registers associated with the Timer0 module is found in Table 7-1.

The Timer0 contained in the CPU core follows the standard baseline definition.

FIGURE 7-1: TIMER0 BLOCK DIAGRAM

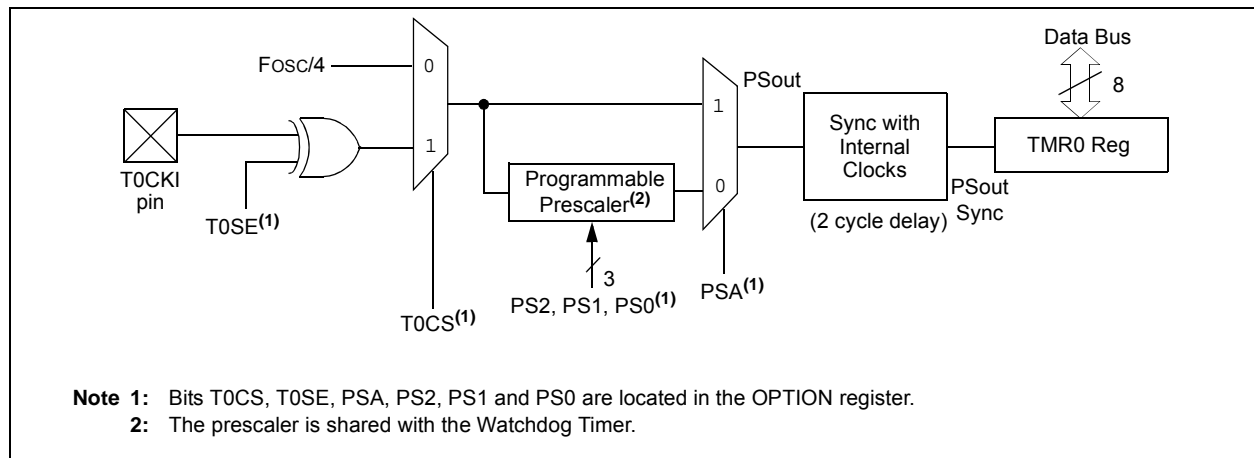
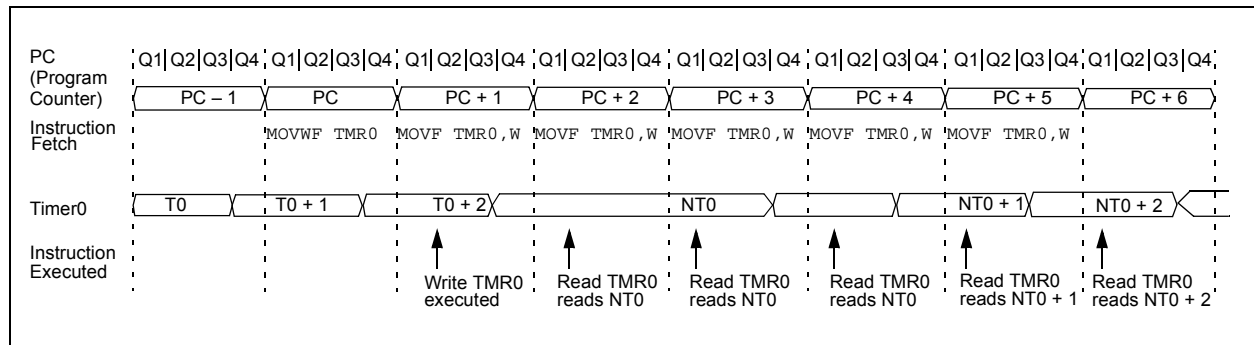

FIGURE 7-2: TIMER0 TIMING: INTERNAL CLOCK/NO PRESCALE



PIC12F529T39A

FIGURE 7-3: TIMER0 TIMING: INTERNAL CLOCK/PRESCALE 1:2

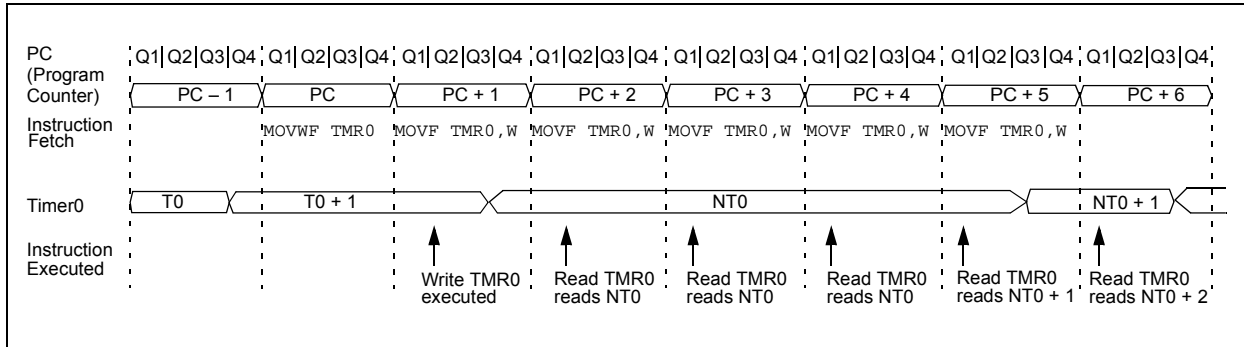

TABLE 7-1: REGISTERS ASSOCIATED WITH TIMER0

Address	Name	Bit 7	Bit 6	Bit 5	Bit 4	Bit 3	Bit 2	Bit 1	Bit 0	Register on Page
01h	TMR0	Timer0 – 8-bit Real-Time Clock/Counter								29*
N/A	OPTION	GPWU	GPPU	T0CS	T0SE	PSA	PS2	PS1	PS0	14
N/A	TRIS	—	—	TRISGPIO5	TRISGPIO4	TRISGPIO3	TRISGPIO2	TRISGPIO1	TRISGPIO0	—

Legend: x = unknown, u = unchanged, – = unimplemented, read as '0'. Shaded cells = unimplemented, read as '0'.

* Page provides register information.

7.1 Using Timer0 with an External Clock

When an external clock input is used for Timer0, it must meet certain requirements. The external clock requirement is due to internal phase clock (Tosc) synchronization. Also, there is a delay in the actual incrementing of Timer0 after synchronization.

7.1.1 EXTERNAL CLOCK SYNCHRONIZATION

When no prescaler is used, the external clock input is the same as the prescaler output. The synchronization of T0CKI with the internal phase clocks is accomplished by sampling the prescaler output on the Q2 and Q4 cycles of the internal phase clocks (Figure 7-4). Therefore, it is necessary for T0CKI to be high for at least two Tosc (and a small RC delay of two Tt0H) and low for at least two Tosc (and a small RC delay of two Tt0H). Refer to the electrical specification of the desired device.

When a prescaler is used, the external clock input is divided by the asynchronous ripple counter-type prescaler, so that the prescaler output is symmetrical. For the external clock to meet the sampling requirement, the ripple counter must be taken into account. Therefore, it is necessary for T0CKI to have a period of at least four Tosc (and a small RC delay of four Tt0H) divided by the prescaler value. The only requirement on T0CKI high and low time is that they do not violate the minimum pulse width requirement of Tt0H. Refer to parameters 40, 41 and 42 in the electrical specification of the desired device.

7.1.2 TIMER0 INCREMENT DELAY

Since the prescaler output is synchronized with the internal clocks, there is a small delay from the time the external clock edge occurs to the time the Timer0 module is actually incremented. Figure 7-4 shows the delay from the external clock edge to the timer incrementing.

FIGURE 7-4: TIMER0 TIMING WITH EXTERNAL CLOCK

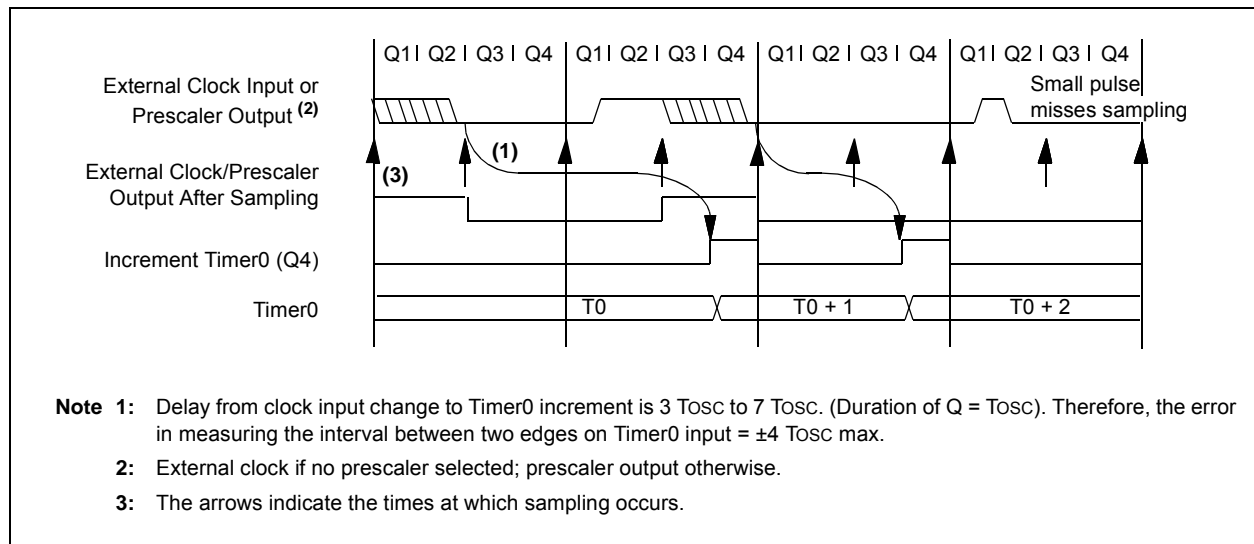

PIC12F529T39A

7.2 Prescaler

An 8-bit counter is available as a prescaler for the Timer0 module or as a postscaler for the Watchdog Timer (WDT), respectively (see [Section 8.6 “Watchdog Timer \(WDT\)”](#)). For simplicity, this counter is being referred to as “prescaler” throughout this data sheet.

Note: The prescaler may be used by either the Timer0 module or the WDT, but not both. Thus, a prescaler assignment for the Timer0 module means that there is no prescaler for the WDT and vice versa.

The PSA and PS<2:0> bits (OPTION<3:0>) determine prescaler assignment and prescale ratio.

When assigned to the Timer0 module, all instructions writing to the TMR0 register (e.g., CLRWF TMR0, MOVWF TMR0, etc.) will clear the prescaler. When assigned to WDT, a CLRWDT instruction will clear the prescaler along with the WDT. The prescaler is neither readable nor writable. On a Reset, the prescaler contains all '0's.

7.2.1 SWITCHING PRESCALER ASSIGNMENT

The prescaler assignment is fully under software control (i.e., it can be changed “on-the-fly” during program execution). To avoid an unintended device Reset, the following instruction sequence ([Example 7-1](#)) must be executed when changing the prescaler assignment from Timer0 to the WDT.

EXAMPLE 7-1: CHANGING PRESCALER (TIMER0 → WDT)

```
CLRWDT          ;Clear WDT
CLRWF  TMR0     ;Clear TMR0 and Prescaler
MOVLW  b'00xx1111'
OPTION

CLRWDT          ;PS<2:0> are 000 or 001
MOVLW  b'00xx1xxx' ;Set Postscaler to
OPTION          ;desired WDT rate
```

To change the prescaler from the WDT to the Timer0 module, use the sequence shown in [Example 7-2](#). This sequence must be used even if the WDT is disabled. A CLRWDT instruction should be executed before switching the prescaler.

EXAMPLE 7-2: CHANGING PRESCALER (WDT → TIMER0)

```
CLRWDT          ;Clear WDT and
                ;prescaler
MOVLW  b'xxxx0xxx' ;Select TMR0, new
                ;prescale value and
                ;clock source
OPTION
```

FIGURE 7-5: BLOCK DIAGRAM OF THE TIMER0/ WDT PRESCALER⁽¹⁾

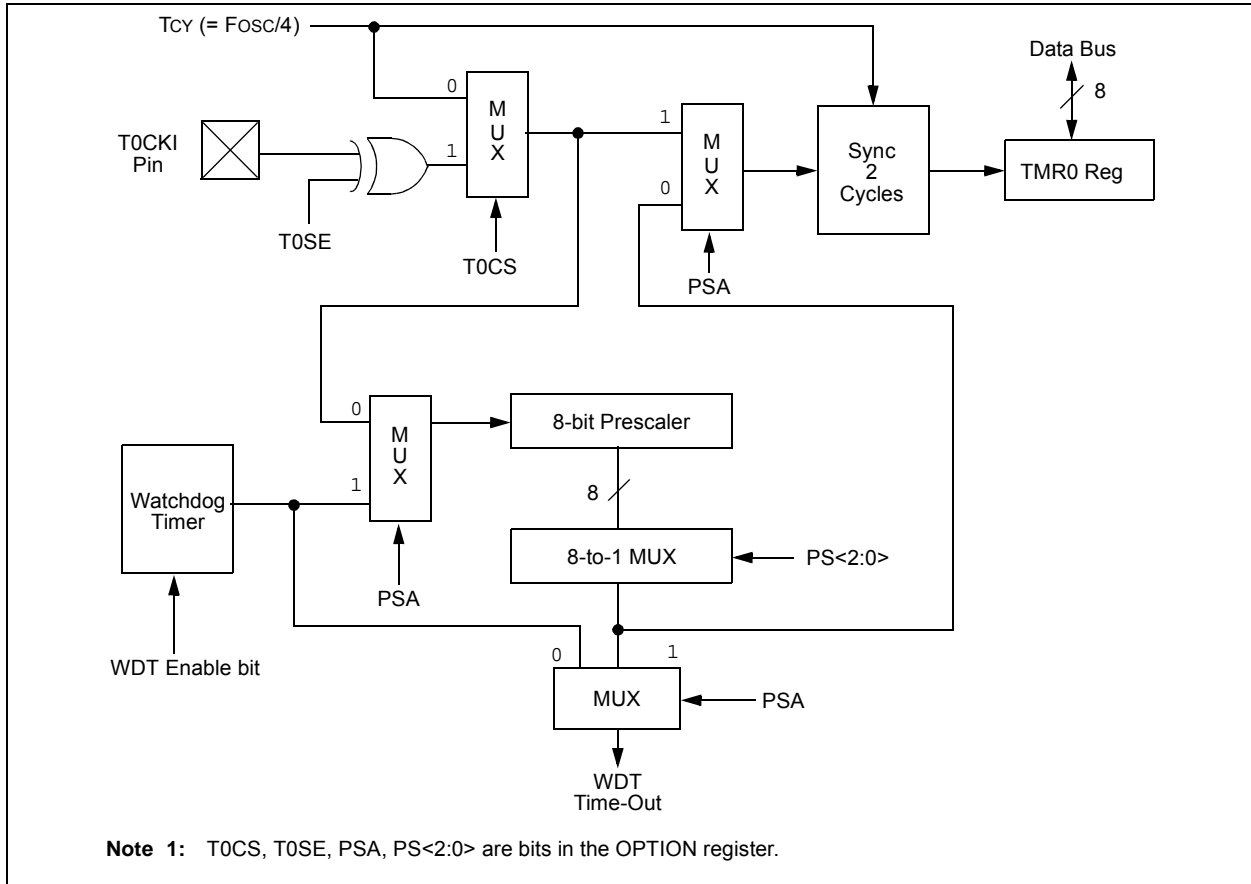

PIC12F529T39A

8.0 SPECIAL FEATURES OF THE CPU

What sets a microcontroller apart from other processors are special circuits that deal with the needs of real-time applications. The PIC12F529T39A microcontroller has a host of such features intended to maximize system reliability, minimize cost through elimination of external components, provide power-saving operating modes and offer code protection. These features are:

- Oscillator Selection
- Reset:
 - Power-on Reset (POR)
 - Device Reset Timer (DRT)
 - Wake-up from Sleep on Pin Change
- Watchdog Timer (WDT)
- Sleep
- Code Protection
- ID Locations
- In-Circuit Serial Programming™

The PIC12F529T39A device has a Watchdog Timer, which can be shut off only through Configuration bit WDTE. It runs off of its own RC oscillator for added reliability. If using XT or LP selectable oscillator options, there is always an 18 ms (nominal) delay provided by the Device Reset Timer (DRT), intended to keep the chip in Reset until the crystal oscillator is stable. If using INTRC or EXTRC, the DRT provides a 1 ms (nominal) delay.

The Sleep mode is designed to offer a very low-current Power-Down mode. The user can wake-up from Sleep through a change-on-input-pins or through a Watchdog Timer time-out. Several oscillator options are also made available to allow the part to fit the application, including an internal 4 MHz or 8 MHz oscillator. The EXTRC oscillator option saves system cost while the LP crystal option saves power. A set of Configuration bits are used to select various options.

8.1 Configuration Bits

The PIC12F529T39A Configuration Words consist of 12 bits. Configuration bits can be programmed to select various device configurations. Two bits are for the selection of the oscillator type; one bit is the Watchdog Timer enable bit, one bit is the MCLR enable bit and six bits are for code protection ([Register 8-1](#)).

REGISTER 8-1: CONFIG: CONFIGURATION WORD REGISTER⁽¹⁾

U-1	P-1	P-1	P-1	P-1	R/P-1	R/P-1	R/P-1	R/P-1	R/P-1	R/P-1	R/P-1
—	CP3	CP2	CP1	CP0	CPDF	IOSCF5	MCLRE	PARITY	WDTE	FOSC1	FOSC0
bit 11											bit 0

Legend:

R = Readable bit	W = Writable bit	U = Unimplemented bit, read as '0'
-n = Value at POR	'1' = Bit is set	'0' = Bit is cleared
		x = Bit is unknown

- bit 11 **Unimplemented:** Read as '1'
- bit 10-7 **CP<3:0>:** Enhanced Code Protect bits
 - 1011 = Code protect disabled
 - 0010 = Code protect enabled
 - All others = Memory access disabled⁽³⁾
- bit 6 **CPDF:** Code Protection bit – Flash Data Memory
 - 1 = Code protection off
 - 0 = Code protection on
- bit 5 **IOSCF5:** Internal Oscillator Frequency Select bit
 - 1 = 8 MHz INTOSC speed
 - 0 = 4 MHz INTOSC speed
- bit 4 **MCLRE:** Master Clear Enable bit
 - 1 = GP3/MCLR pin functions as MCLR
 - 0 = GP3/MCLR pin functions as GP3, MCLR internally tied to VDD
- bit 3 **PARITY:** Configuration Word Parity bit⁽⁴⁾
 - 1 = Parity bit set
 - 0 = Parity bit clear
- bit 2 **WDTE:** Watchdog Timer Enable bit
 - 1 = WDT enabled
 - 0 = WDT disabled
- bit 1-0 **FOSC<1:0>:** Oscillator Selection bits
 - 00 = LP oscillator with 18 ms DRT⁽²⁾
 - 01 = XT oscillator with 18 ms DRT⁽²⁾
 - 10 = INTRC with 1 ms DRT⁽²⁾
 - 11 = EXTRC with 1 ms DRT⁽²⁾

Note 1: Refer to the “PIC12F529T48A/T39A Memory Programming Specification” (DS41619) to determine how to program/erase the Configuration Word.

2: DRT length (18 ms or 1 ms) is a function of clock mode selection. It is the responsibility of the application designer to ensure the use of either 18 ms (nominal) DRT or the 1 ms (nominal) DRT will result in acceptable operation. Refer to [Figure 12-1](#) for VDD rise time and stability requirements for this mode of operation.

3: See [Section 8.9 “Program Verification/Code Protection”](#).

4: Set or clear to create odd parity with Configuration Word excluding CP<3:0>.

PIC12F529T39A

8.2 Oscillator Configurations

8.2.1 OSCILLATOR TYPES

The PIC12F529T39A device can be operated in up to four different oscillator modes. The user can program using the Configuration bits (FOSC<1:0>), to select one of these modes:

- LP: Low-Power Crystal
- XT: Crystal/Resonator
- INTRC: Internal 4 MHz or 8 MHz Oscillator
- EXTRC: External Resistor/Capacitor

8.2.2 CRYSTAL OSCILLATOR/CERAMIC RESONATORS

In XT or LP modes, a crystal or ceramic resonator is connected to the (GP5)/OSC1/(CLKIN) and (GP4)/OSC2 pins to establish oscillation (Figure 8-1). The PIC12F529T39A oscillator designs require the use of a parallel cut crystal. Use of a series cut crystal may give a frequency out of the crystal manufacturers specifications. When in XT or LP modes, the device can have an external clock source drive the (GP5)/OSC1/CLKIN pin (Figure 8-2). When the part is used in this manner, the output drive levels on the OSC2 pin are very weak. This pin should be left open and unloaded. Also when using this mode, the external clock should observe the frequency limits for the clock mode chosen (XT or LP).

Note 1: The user should verify that the device oscillator starts and performs as expected. Adjusting the loading capacitor values and/or the Oscillator mode may be required.

FIGURE 8-1: CRYSTAL OPERATION (OR CERAMIC RESONATOR) (XT OR LP OSC CONFIGURATION)

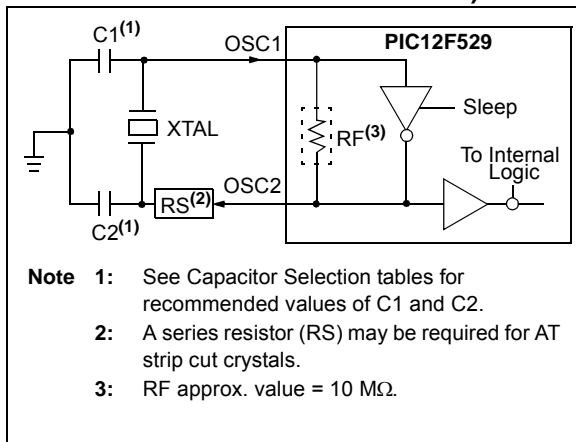

FIGURE 8-2: EXTERNAL CLOCK INPUT OPERATION (XT OR LP OSC CONFIGURATION)

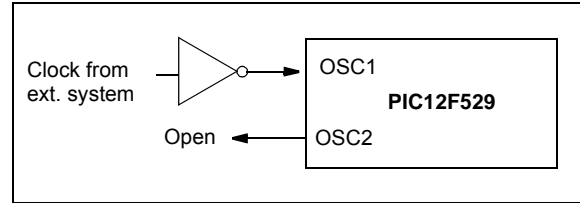

TABLE 8-1: CAPACITOR SELECTION FOR CERAMIC RESONATORS

Osc Type	Resonator Freq.	Cap. Range C1	Cap. Range C2
XT	4.0 MHz	30 pF	30 pF

Note: Component values shown are for design guidance only. Since each resonator has its own characteristics, the user should consult the resonator manufacturer for appropriate values of external components.

TABLE 8-2: CAPACITOR SELECTION FOR CRYSTAL OSCILLATOR – PIC12F529T39A⁽²⁾

Osc Type	Resonator Freq.	Cap. Range C1	Cap. Range C2
LP	32 kHz ⁽¹⁾	15 pF	15 pF
XT	200 kHz	47-68 pF	47-68 pF
	1 MHz	15 pF	15 pF
	4 MHz	15 pF	15 pF

Note 1: For VDD > 4.5V, C1 = C2 ≈ 30 pF is recommended.

2: Component values shown are for design guidance only. Rs may be required to avoid overdriving crystals with low-drive level specification. Since each crystal has its own characteristics, the user should consult the crystal manufacturer for appropriate values of external components.

8.2.3 EXTERNAL CRYSTAL OSCILLATOR CIRCUIT

Either a pre-packaged oscillator or a simple oscillator circuit with TTL gates can be used as an external crystal oscillator circuit. Pre-packaged oscillators provide a wide operating range and better stability. A well-designed crystal oscillator will provide good performance with TTL gates. Two types of crystal oscillator circuits can be used: one with parallel resonance, or one with series resonance.

Figure 8-3 shows implementation of a parallel resonant oscillator circuit. The circuit is designed to use the fundamental frequency of the crystal. The 74AS04 inverter performs the 180-degree phase shift that a parallel oscillator requires. The 4.7 kΩ resistor provides the negative feedback for stability. The 10 kΩ potentiometers bias the 74AS04 in the linear region. This circuit could be used for external oscillator designs.

FIGURE 8-3: EXTERNAL PARALLEL RESONANT CRYSTAL OSCILLATOR CIRCUIT

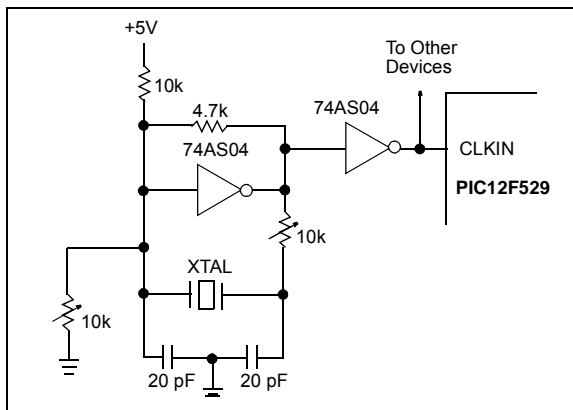
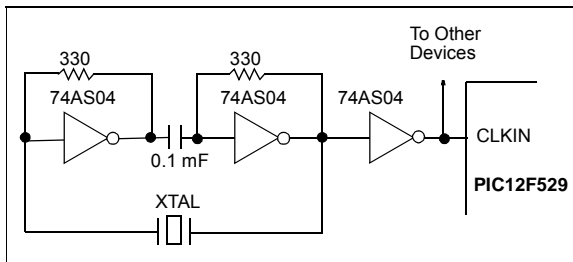

Figure 8-4 shows a series resonant oscillator circuit. This circuit is also designed to use the fundamental frequency of the crystal. The inverter performs a 180-degree phase shift in a series resonant oscillator circuit. The 330Ω resistors provide the negative feedback to bias the inverters in their linear region.

FIGURE 8-4: EXTERNAL SERIES RESONANT CRYSTAL OSCILLATOR CIRCUIT



8.2.4 EXTERNAL RC OSCILLATOR

For timing insensitive applications, the RC circuit option offers additional cost savings. The RC oscillator frequency is a function of the supply voltage, the resistor (R_{EXT}) and capacitor (C_{EXT}) values, and the operating temperature. In addition to this, the oscillator frequency will vary from unit-to-unit due to normal process parameter variation. Furthermore, the difference in lead frame capacitance between package types will also affect the oscillation frequency, especially for low C_{EXT} values. The user also needs to take into account variation due to tolerance of external R and C components used.

Figure 8-5 shows how the R/C combination is connected to the PIC12F529T39A device. For R_{EXT} values below 3.0 kΩ, the oscillator operation may become unstable, or stop completely. For very high R_{EXT} values (e.g., 1 MΩ), the oscillator becomes sensitive to noise, humidity and leakage. It is recommended keeping R_{EXT} between 5.0 kΩ and 100 kΩ.

Although the oscillator will operate with no external capacitor ($C_{EXT} = 0$ pF), it is recommended using values above 20 pF for noise and stability reasons. With no or small external capacitance, the oscillation frequency can vary dramatically due to changes in external capacitances, such as PCB trace capacitance or package lead frame capacitance. See Figure 12-1 and Figure 12-2.

FIGURE 8-5: EXTERNAL RC OSCILLATOR MODE

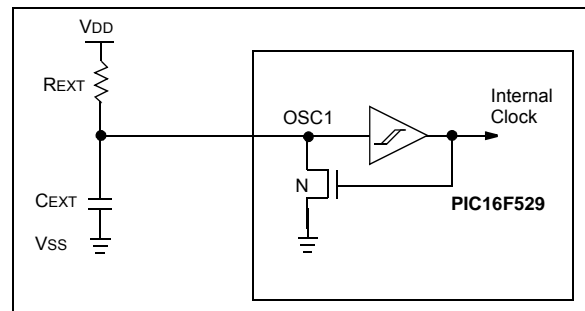

PIC12F529T39A

8.2.5 INTERNAL 4/8 MHz RC OSCILLATOR

The internal RC oscillator provides a fixed 4/8 MHz (nominal) system clock at $V_{DD} = 3.5V$ and $25^{\circ}C$, (see [Section 12.0 “Electrical Characteristics”](#) for information on variation over voltage and temperature).

In addition, a calibration instruction is programmed into the last address of memory, which contains the calibration value for the internal RC oscillator. This location is always non-code-protected, regardless of the code-protect settings. This value is programmed as a `MOVLW XX` instruction where `XX` is the calibration value, and is placed at the Reset vector. This will load the `W` register with the calibration value upon Reset and the PC will then roll over to the users program at address `0x000`. The user then has the option of writing the value to the `OSCCAL` register (`05h`) or ignoring it.

`OSCCAL`, when written to with the calibration value, will “trim” the internal oscillator to remove process variation from the oscillator frequency.

Note: Erasing the device will also erase the pre-programmed internal calibration value for the internal oscillator. The calibration value must be read prior to erasing the part so it can be reprogrammed correctly later.

For the PIC12F529T39A device, only bits $\langle 7:1 \rangle$ of `OSCCAL` are used for calibration. See [Register 4-3](#) for more information.

Note: The bit 0 of the `OSCCAL` register is unimplemented and should be written as ‘0’ when modifying `OSCCAL` for compatibility with future devices.

8.3 Reset

The device differentiates between various kinds of Reset:

- Power-on Reset (POR)
- \overline{MCLR} Reset during normal operation
- \overline{MCLR} Reset during Sleep
- WDT Time-out Reset during normal operation
- WDT Time-out Reset during Sleep
- Wake-up from Sleep on pin change

Some registers are not reset in any way, and they are unknown on Power-on Reset (POR) and unchanged in any other Reset. Most other registers are reset to “Reset state” on Power-on Reset (POR), \overline{MCLR} , WDT or Wake-up on pin change Reset during normal operation. They are not affected by a WDT Reset during Sleep or \overline{MCLR} Reset during Sleep, since these Resets are viewed as resumption of normal operation.

TABLE 8-3: RESET CONDITIONS FOR REGISTERS

Register	Address	Power-on Reset	\overline{MCLR} Reset, WDT Time-out, Wake-up On Pin Change
W	—	q q q q q q q 0 ⁽¹⁾	q q q q q q q 0 ⁽¹⁾
INDF	00h	x x x x x x x x	u u u u u u u u
TMR0	01h	x x x x x x x x	u u u u u u u u
PCL	02h	1 1 1 1 1 1 1 1	1 1 1 1 1 1 1 1
STATUS	03h	0 0 0 1 1 x x x	q 0 0 q q u u u ^{(2), (3)}
FSR	04h	1 1 0 x x x x x	1 1 u u u u u u
OSCCAL	05h	1 1 1 1 1 1 1 -	u u u u u u u -
PORTB	06h	- - x x x x x x	- - u u u u u u
OPTION	—	1 1 1 1 1 1 1 1	1 1 1 1 1 1 1 1
TRIS	—	- - 1 1 1 1 1 1	- - 1 1 1 1 1 1
BSR	—	- - - - - 0 0 0	- - - - - 0 0 0
EECON	21h	- - - 0 x 0 0 0	- - - 0 q 0 0 0
EEDATA	25h	x x x x x x x x	u u u u u u u u
EEADR	26h	- - x x x x x x	- - u u u u u u

Legend: u = unchanged, x = unknown, - = unimplemented bit, read as ‘0’, q = value depends on condition.

- Note 1:** Bits $\langle 7:1 \rangle$ of `W` register contain oscillator calibration values due to `MOVLW XX` instruction at top of memory.
- Note 2:** See [Table 8-4](#) for Reset value for specific conditions.
- Note 3:** If Reset was due to wake-up on pin change, then bit 7 = 1. All other Resets will cause bit 7 = 0.

TABLE 8-4: RESET CONDITION FOR SPECIAL REGISTERS

	STATUS Addr: 03h
Power-on Reset	0-01 1xxx
MCLR Reset during normal operation	0-0u uuuu
MCLR Reset during Sleep	0-01 0uuu
WDT Reset during Sleep	0-00 0uuu
WDT Reset normal operation	0-00 uuuu
Wake-up from Sleep on pin change	1-01 0uuu

Legend: u = unchanged, x = unknown

8.3.1 MCLR ENABLE

This Configuration bit, when unprogrammed (left in the '1' state), enables the external MCLR function. When programmed, the MCLR function is tied to the internal VDD and the pin is assigned to be a I/O. See [Figure 8-6](#).

FIGURE 8-6: MCLR SELECT

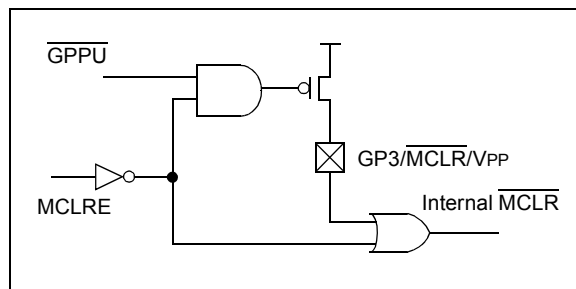

8.4 Power-on Reset (POR)

The PIC12F529T39A device incorporates an on-chip Power-on Reset (POR) circuitry, which provides an internal chip Reset for most power-up situations.

The on-chip POR circuit holds the chip in Reset until VDD has reached a high enough level for proper operation. To take advantage of the internal POR, program the GP3/MCLR/VPP pin as MCLR and tie through a resistor to VDD, or program the pin as GP3, in which case, an internal weak pull-up resistor is implemented using a transistor (refer to [Table 12-4](#) for the pull-up resistor ranges). This will eliminate external RC components usually needed to create a Power-on Reset. A maximum rise time for VDD is specified. See [Section 12.0 "Electrical Characteristics"](#) for details.

When the devices start normal operation (exit the Reset condition), device operating parameters (voltage, frequency, temperature,...) must be met to ensure operation. If these conditions are not met, the devices must be held in Reset until the operating parameters are met.

A simplified block diagram of the on-chip Power-on Reset circuit is shown in [Figure 8-7](#).

The Power-on Reset circuit and the Device Reset Timer (see [Section 8.5 "Device Reset Timer \(DRT\)"](#)) circuit are closely related. On power-up, the Reset latch is set and the DRT is reset. The DRT timer begins counting once it detects MCLR to be high. After the time-out period, which is typically 18 ms or 1 ms, it will reset the Reset latch and thus end the on-chip Reset signal.

A power-up example where MCLR is held low is shown in [Figure 8-8](#). VDD is allowed to rise and stabilize before bringing MCLR high. The chip will actually come out of Reset TDRT after MCLR goes high.

In [Figure 8-9](#), the on-chip Power-on Reset feature is being used (MCLR and VDD are tied together or the pin is programmed to be GP3). The VDD is stable before the Start-up timer times out and there is no problem in getting a proper Reset. However, [Figure 8-10](#) depicts a problem situation where VDD rises too slowly. The time between when the DRT senses that MCLR is high and when MCLR and VDD actually reach their full value, is too long. In this situation, when the start-up timer times out, VDD has not reached the VDD (min) value and the chip may not function correctly. For such situations, we recommend that external RC circuits be used to achieve longer POR delay times ([Figure 8-9](#)).

Note: When the devices start normal operation (exit the Reset condition), device operating parameters (voltage, frequency, temperature, etc.) must be met to ensure operation. If these conditions are not met, the device must be held in Reset until the operating conditions are met.

For additional information, refer to Application Note AN522, "Power-Up Considerations" (DS00522).

PIC12F529T39A

FIGURE 8-7: SIMPLIFIED BLOCK DIAGRAM OF ON-CHIP RESET CIRCUIT

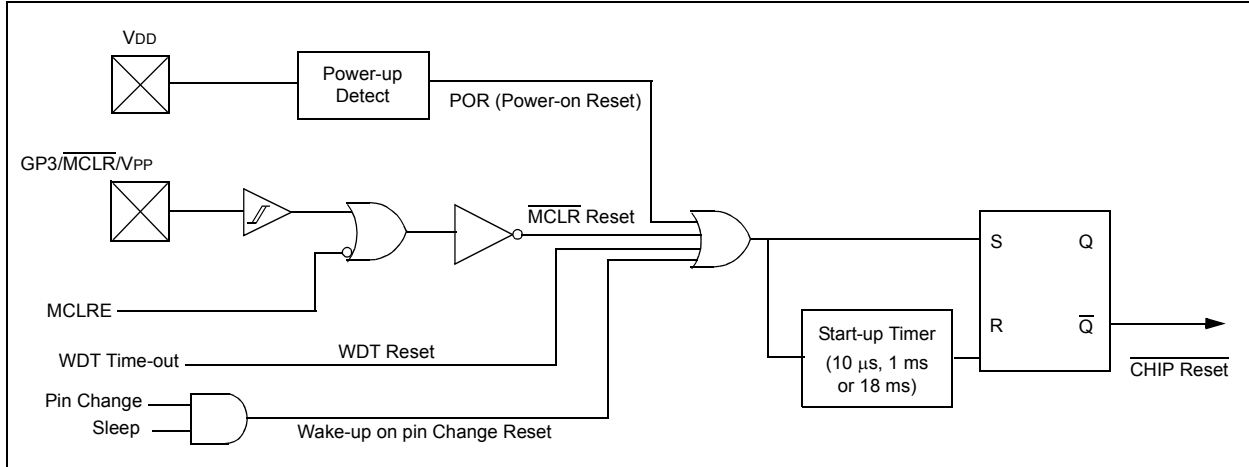

FIGURE 8-8: TIME-OUT SEQUENCE ON POWER-UP ($\overline{\text{MCLR}}$ PULLED LOW)

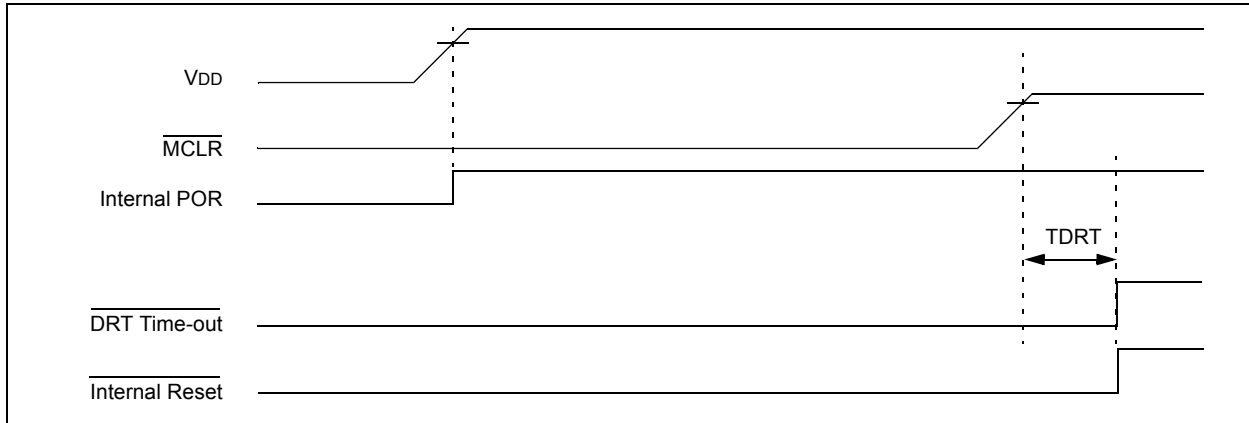

FIGURE 8-9: TIME-OUT SEQUENCE ON POWER-UP ($\overline{\text{MCLR}}$ TIED TO V_{DD}): FAST V_{DD} RISE TIME

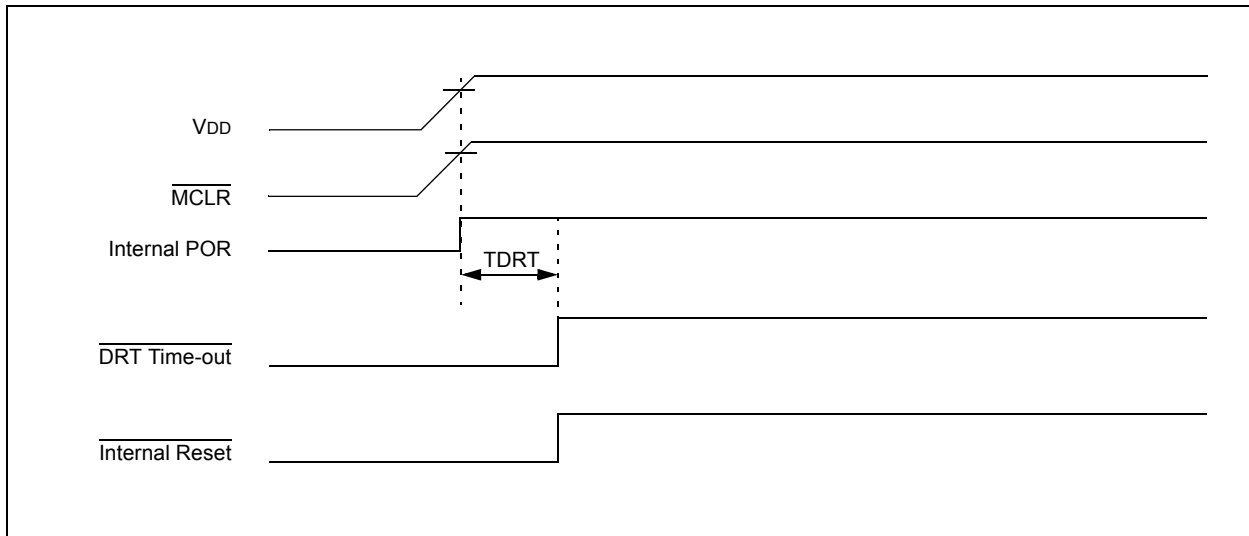
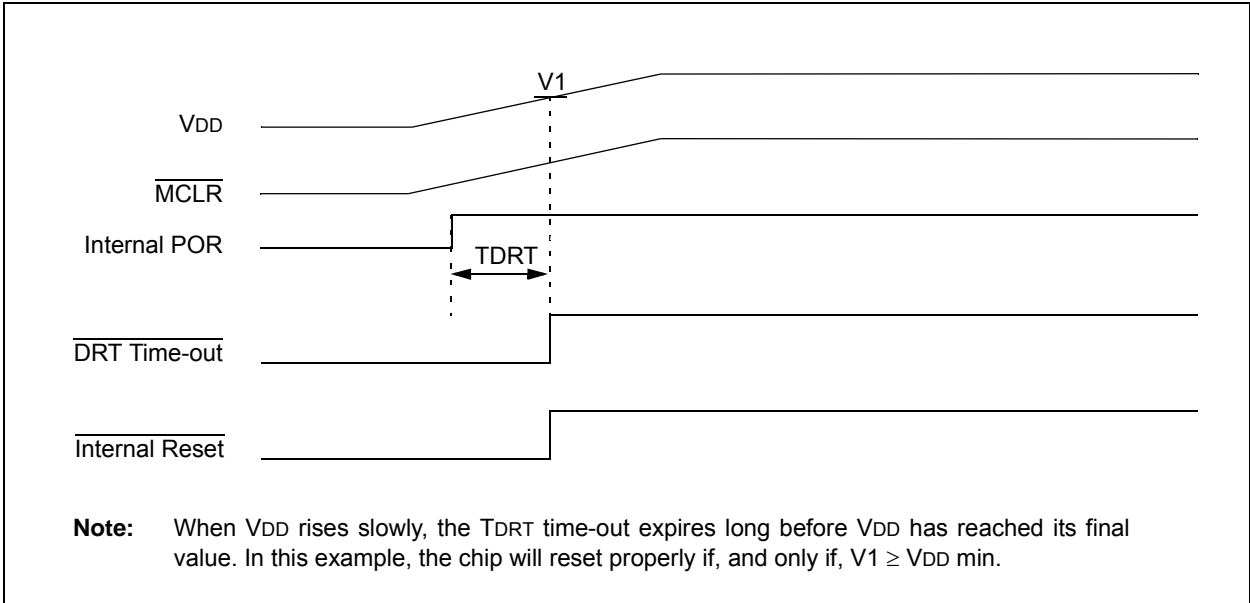

FIGURE 8-10: TIME-OUT SEQUENCE ON POWER-UP ($\overline{\text{MCLR}}$ TIED TO V_{DD}): SLOW V_{DD} RISE TIME



PIC12F529T39A

8.5 Device Reset Timer (DRT)

On the PIC12F529T39A device, the DRT runs any time the device is powered up. DRT runs from Reset and varies based on oscillator selection and Reset type (see [Table 8-5](#)).

The DRT operates on an internal RC oscillator. The processor is kept in Reset as long as the DRT is active. The DRT delay allows V_{DD} to rise above $V_{DD\ min}$. and for the oscillator to stabilize.

Oscillator circuits based on crystals or ceramic resonators require a certain time after power-up to establish a stable oscillation. The on-chip DRT keeps the devices in a Reset condition after \overline{MCLR} has reached a logic high ($V_{IH\ MCLR}$) level. Programming GP3/MCLR/VPP as MCLR and using an external RC network connected to the \overline{MCLR} input is not required in most cases. This allows savings in cost-sensitive and/or space restricted applications, as well as allowing the use of the GP3/MCLR/VPP pin as a general purpose input.

The Device Reset Time delays will vary from chip-to-chip due to V_{DD} , temperature and process variation. See AC parameters for details.

The DRT will also be triggered upon a Watchdog Timer time-out from Sleep. This is particularly important for applications using the WDT to wake from Sleep mode automatically.

Reset sources are POR, \overline{MCLR} , WDT time-out and wake-up on pin change. See [Section 8.8.2 “Wake-up from Sleep”](#), [Notes 1, 2 and 3](#).

TABLE 8-5: DRT (DEVICE RESET TIMER PERIOD)

Oscillator Configuration	POR Reset	Subsequent Resets
INTOSC, EXTRC	1 ms (typical)	10 μ s (typical)
LP, XT	18 ms (typical)	18 ms (typical)

8.6 Watchdog Timer (WDT)

The Watchdog Timer (WDT) is a free running on-chip RC oscillator, which does not require any external components. This RC oscillator is separate from the external RC oscillator of the (GP5)/OSC1/CLKIN pin and the internal 4 or 8 MHz oscillator. This means that the WDT will run even if the main processor clock has been stopped, for example, by execution of a SLEEP instruction. During normal operation or Sleep, a WDT Reset or wake-up Reset, generates a device Reset.

The TO bit (STATUS<4>) will be cleared upon a Watchdog Timer Reset.

The WDT can be permanently disabled by programming the configuration WDTE as a '0' (see [Section 8.1 “Configuration Bits”](#)). Refer to the PIC12F529T39A Programming Specification (DS41316) to determine how to access the Configuration Word.

8.6.1 WDT PERIOD

The WDT has a nominal time-out period of 18 ms, (with no prescaler). If a longer time-out period is desired, a prescaler with a division ratio of up to 1:128 can be assigned to the WDT (under software control) by writing to the OPTION register. Thus, a time-out period of a nominal 2.3 seconds can be realized. These periods vary with temperature, V_{DD} and part-to-part process variations (see DC specs).

Under worst-case conditions ($V_{DD} = \text{Min.}$, Temperature = Max., max. WDT prescaler), it may take several seconds before a WDT time-out occurs.

8.6.2 WDT PROGRAMMING CONSIDERATIONS

The CLRWDT instruction clears the WDT and the postscaler, if assigned to the WDT, and prevents it from timing out and generating a device Reset.

The SLEEP instruction resets the WDT and the postscaler, if assigned to the WDT. This gives the maximum Sleep time before a WDT wake-up Reset.

FIGURE 8-11: WATCHDOG TIMER BLOCK DIAGRAM

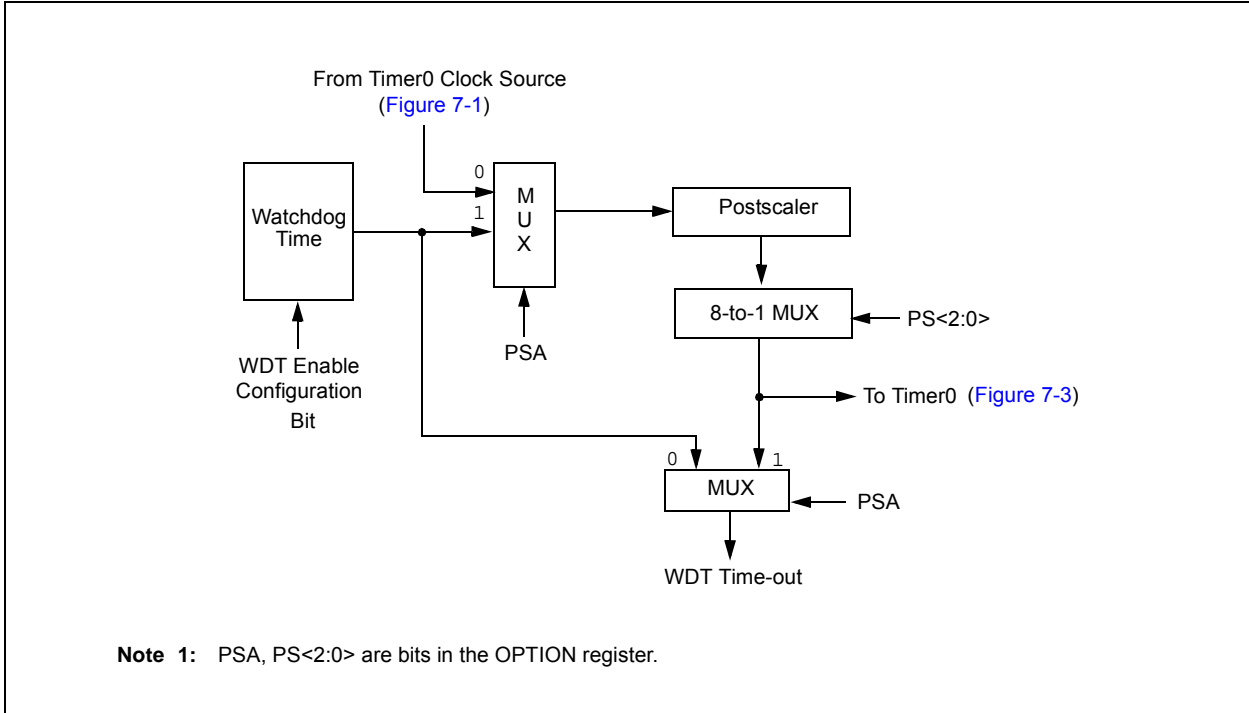

TABLE 8-6: SUMMARY OF REGISTER ASSOCIATED WITH THE WATCHDOG TIMER

Name	Bit 7	Bit 6	Bit 5	Bit 4	Bit 3	Bit 2	Bit 1	Bit 0	Register on Page
OPTION	GPWU	GPPU	T0CS	T0SE	PSA	PS2	PS1	PS0	14

Legend: Shaded boxes = Not used by Watchdog Timer.

PIC12F529T39A

8.7 Time-out Sequence, Power-down and Wake-up from Sleep Status Bits (\overline{TO} , \overline{PD} , GPWUF)

The \overline{TO} , \overline{PD} and (GPWUF) bits in the STATUS register can be tested to determine if a Reset condition has been caused by a power-up condition, a MCLR or Watchdog Timer (WDT) Reset.

TABLE 8-7: $\overline{TO}/\overline{PD}/(GPWUF)$ STATUS AFTER RESET

GPWUF	\overline{TO}	\overline{PD}	Reset Caused By
0	0	0	WDT wake-up from Sleep
0	0	u	WDT time-out (not from Sleep)
0	1	0	MCLR wake-up from Sleep
0	1	1	Power-up
0	u	u	MCLR not during Sleep
1	1	0	Wake-up from Sleep on pin change

Legend: u = unchanged

Note 1: The \overline{TO} , \overline{PD} and GPWUF bits maintain their status (u) until a Reset occurs. A low-pulse on the MCLR input does not change the \overline{TO} , \overline{PD} and GPWUF Status bits.

8.8 Power-down Mode (Sleep)

A device may be powered down (Sleep) and later powered up (wake-up from Sleep).

8.8.1 SLEEP

The Power-Down mode is entered by executing a SLEEP instruction.

If enabled, the Watchdog Timer will be cleared but keeps running, the \overline{TO} bit (STATUS<4>) is set, the \overline{PD} bit (STATUS<3>) is cleared and the oscillator driver is turned off. The I/O ports maintain the status they had before the SLEEP instruction was executed (driving high, driving low or high-impedance).

Note: A Reset generated by a WDT time-out does not drive the MCLR pin low.

For lowest current consumption while powered down, the T0CKI input should be at VDD or VSS and the GP3/MCLR/VPP pin must be at a logic high level if MCLR is enabled.

8.8.2 WAKE-UP FROM SLEEP

The device can wake-up from Sleep through one of the following events:

5. An external Reset input on GP3/MCLR/VPP pin, when configured as MCLR.
6. A Watchdog Timer Time-out Reset (if WDT was enabled).
7. A change on input pin GP0, GP1 and GP3 when wake-up on change is enabled.

These events cause a device Reset. The \overline{TO} , \overline{PD} and GPWUF bits can be used to determine the cause of device Reset. The \overline{TO} bit is cleared if a WDT time-out occurred (and caused wake-up). The \overline{PD} bit, which is set on power-up, is cleared when SLEEP is invoked. The GPWUF bit indicates a change in state while in Sleep at pins GP0, GP1 and GP3 (since the last file or bit operation on GPIO port).

Note: **Caution:** Right before entering Sleep, read the input pins. When in Sleep, wake-up occurs when the values at the pins change from the state they were in at the last reading. If a wake-up on change occurs and the pins are not read before re-entering Sleep, a wake-up will occur immediately even if no pins change while in Sleep mode.

The WDT is cleared when the device wakes from Sleep, regardless of the wake-up source.

8.9 Program Verification/Code Protection

Code protection is enabled or disabled by writing the correct value to the CP<3:0> bits of the Configuration register. These bits must be written every time the device is erased.

If the code protection bits have not been enabled, the on-chip program and data memory can be read out for verification purposes.

The last location (the oscillator calibration value) can be read, regardless of the setting of the program memory's code protection bit. If the code-protect bit specific to the Flash data memory is programmed, then none of the contents of this memory region can be verified externally.

Refer to *PIC12F529T48A/T39A Memory Programming Specification* (DS41619) for more information on programming the Configuration Word.

Note: The device code protection must be disabled before attempting to program Flash memory.

8.10 ID Locations

Four memory locations are designated as ID locations where users can store checksum or other code identification numbers. These locations are not accessible during normal execution, but are readable and writable during program/verify.

Use only the lower four bits of the ID locations. The upper bits should be programmed as '0's.

8.11 In-Circuit Serial Programming™

The PIC12F529T39A device can be serially programmed while in the end application circuit. This is simply done with two lines for clock and data, and three other lines for power, ground and the programming voltage. This allows users to manufacture boards with unprogrammed PIC12F519 device and then program the PIC12F519 device just before shipping the product. This also allows the most recent firmware, or a custom firmware, to be programmed.

The PIC12F529T39A device is placed into a Program/Verify mode by holding the GP1 and GP0 pins low while raising the MCLR (VPP) pin from V_{IL} to V_{IH} (see programming specification). The GP1 pin becomes the programming clock, and the GP0 pin becomes the programming data. Both GP1 and GP0 pins are Schmitt Trigger inputs in this mode.

After Reset, a 6-bit command is then supplied to the device. Depending on the command, 14 bits of program data are then supplied to or from the device, depending if the command was a Load or a Read. For complete details of serial programming, please refer to the "*PIC12F529T48A/T39A Memory Programming Specification*," (DS41619).

A typical In-Circuit Serial Programming connection is shown in [Figure 8-12](#).

FIGURE 8-12: TYPICAL IN-CIRCUIT SERIAL PROGRAMMING CONNECTION

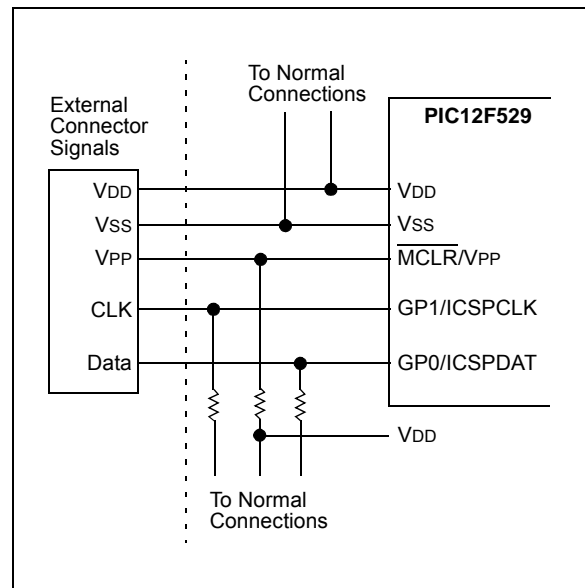

TABLE 9-1: RF TRANSMITTER PIN DESCRIPTION

Name	Function	Input Type	Output Type	Description
VDDRF	VDDRF	Power	—	RF Power Supply
CTRL	CTRL	CMOS	—	Configuration Selection and Configuration Clock
RFOUT	RFOUT	—	RF	Transmitter RF output
VSSRF	VSSRF	Power	—	RF Power Supply
DATA	DATA	CMOS	CMOS	Configuration Data and Transmit Data
XTAL	XTAL	XTAL	—	Crystal Oscillator

Note: The RF transmitter pins are independent from the microcontroller pins.

The RF transmitter contains of a sigma-delta fractional-N Phase-Locked Loop (PLL) frequency synthesizer. Frequency Shift Keying (FSK) modulation is made inside the PLL bandwidth. On-Off Keying (OOK) modulation is made by turning on and off the Power Amplifier (PA).

The reference frequency is generated by an internal crystal oscillator. An external quartz crystal resonator is connected to the XTAL pin and Ground (VSSRF). The choice of crystal frequency depends on the frequency band of choice.

The RF transmitter can deliver 0 dBm or +10 dBm into a 50Ω load via the RFOUT pin. An external matching network is required for each power setting and frequency band for the best efficiency to the antenna.

9.2 Configuring the RF Transmitter

The CTRL and DATA pins are used to configure the RF transmitter for transmit frequency, output power, modulation, FSK frequency deviation, and sleep time. Once configured, the DATA pin is used to encode transmit data.

9.2.1 POWER-ON RESET (POR)

At power-on, the CTRL pin is sampled as shown in Figure 9-2 and depending on the CTRL pin logic level, the RF transmitter will enter one of two Power-on Reset (POR) values as shown in Table 9-3 and Table 9-4. To continue using the RF transmitter with these POR values, maintain the CTRL pin stable and at the powered-on logic level. With the DATA pin at logic '0', the RF transmitter will enter Sleep mode.

Note: It is recommended that a weak pull-up or pull-down resistor be placed on the CTRL pin to ensure the desired preset mode is selected at power-on.

FIGURE 9-2: MODE SELECTION TIMING DIAGRAM

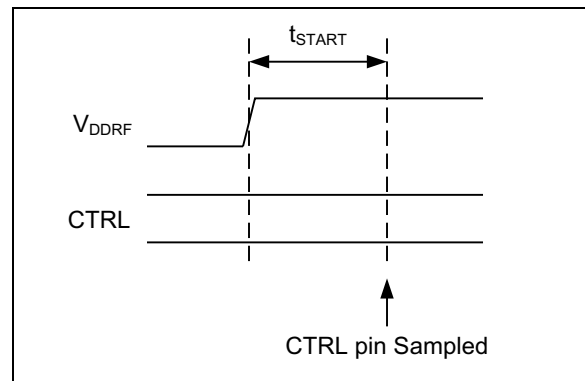

If the POR settings are satisfactory for the application, a microcontroller output pin can be freed by placing a weak pull-up or pull-down resistor on the CTRL pin. Only the DATA pin needs to be connected to an I/O pin.

9.2.2 RF TRANSMITTER REGISTERS

RF transmitter has three registers: Application, Frequency, and Status. These are used to write and read configuration parameters related to transmit frequency, output power, modulation, FSK frequency deviation, and Sleep time. A summary of register values are shown in Table 9-2. A detailed explanation of Application register is shown in Table 9-3, Frequency register values in Table 9-4, and STATUS register in Table 9-5.

To access the registers, the DATA line is sampled at each low-to-high transition on the CTRL pin. A total of 24 transitions are required on the CTRL pin to successfully write or read a value in the registers. Register write and read operations are shown in Figure 9-3.

Writing and reading the RF transmitter registers should be done when the device is in Sleep mode. See Section 9.2.4 "Sleep Mode".

PIC12F529T39A

In the event that spurious activity (for example MCU interrupt or Reset) or less than 24 clock cycles on the CTRL pin, a special sequence over the CTRL and

DATA pins can be used to recover serial communications with the RF transmitter. The recover sequence is shown in Figure 9-4.

FIGURE 9-3: REGISTER WRITE AND READ OPERATIONS

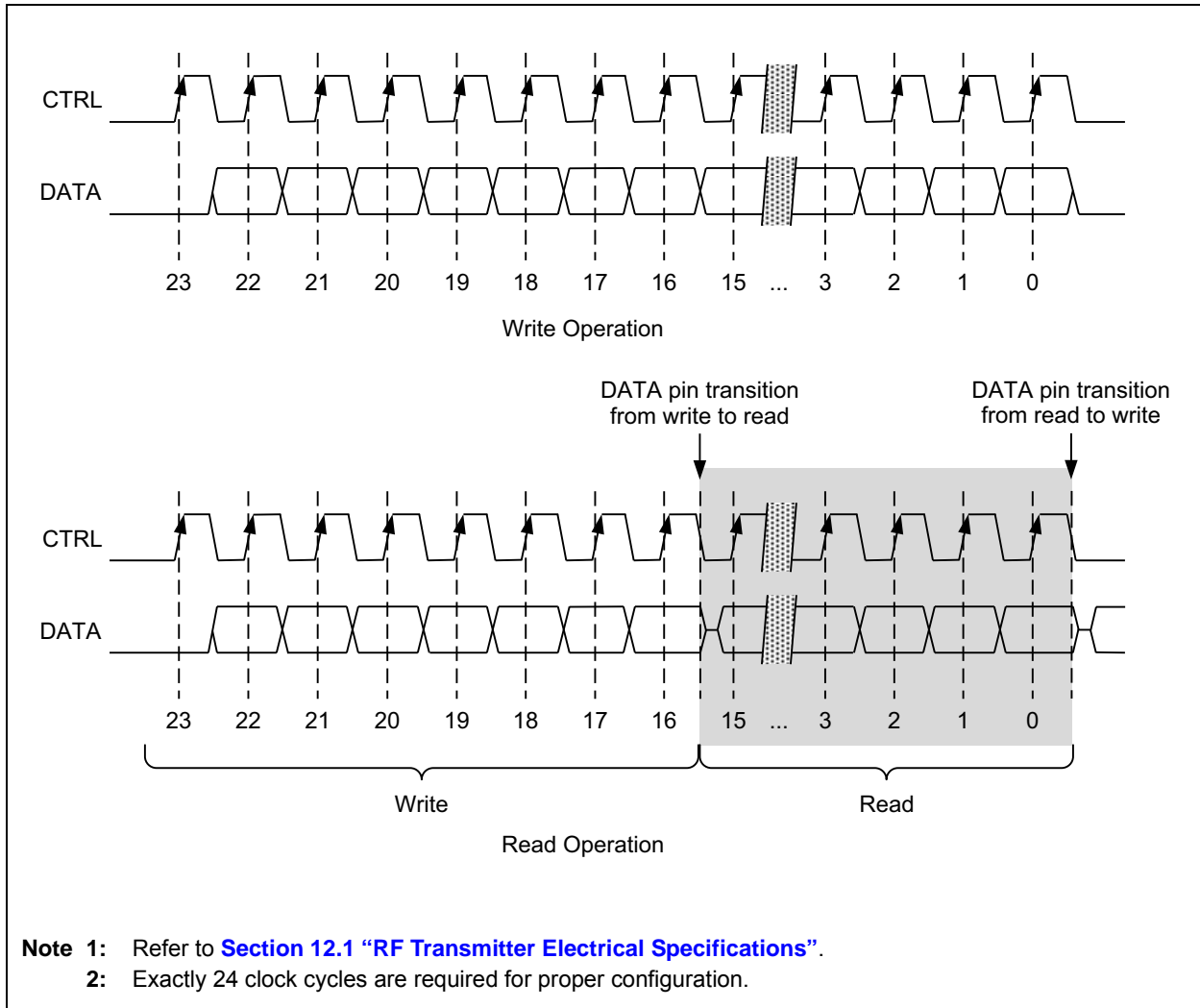

FIGURE 9-4: RECOVERY SEQUENCE TIMING

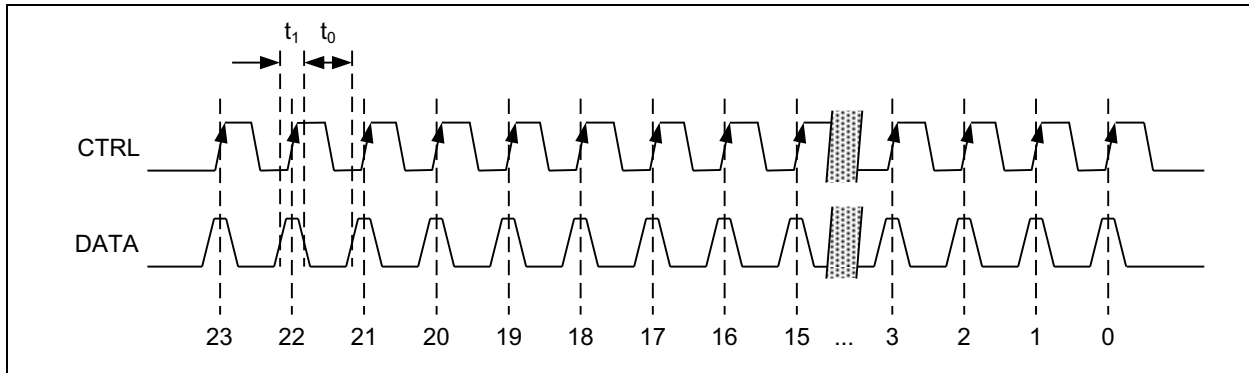

TABLE 9-2: RF TRANSMITTER REGISTER SUMMARY

23	22	21	20	19	18	17	16	15	14	13	12	11	10	9	8	7	6	5	4	3	2	1	0	Instruction	
0	0	0	0	0	0	0	0	DA<15:0>																Write	Application Register (see Table 9-3)
0	0	1	1	0	0	1	1	DA<15:0>																Read	
0	0	0	1	1	DF<18:0>																Write	Frequency Register (see Table 9-4)			
0	1	0	0	0	1	0	0	DF<15:0>																Read	
0	1	0	1	0	1	0	1	DV<7:0>						DS<4:0>				DF<18:16>				Read	STATUS Register (see Table 9-5)		

TABLE 9-3: APPLICATION REGISTER

Bit	Name	Value	Setting	Power-on Reset		Notes
				CTRL = 0	CTRL = 1	
DA15	Mode	0	Automatic	0	0	Refer to Section 9.2.5 “Manual Transmit Mode”.
		1	Manual			
DA14	Modulation	0	FSK	0	1	Refer to Section 9.3 “Modulation Selection”.
		1	OOK			
DA13	Band	0	310-450 MHz	1	0	Refer to Section 9.4 “Frequency Selection and Configuration”.
		1	860-870 MHz 902-928 MHz			
DA<12:5>	Frequency Deviation (f_{DEV})	—	—	—	0x06 ⁽¹⁾	FSK mode only. Refer to Section 9.4.3 “Frequency Calculation”.
DA4	Output Power	0	0 dBm	1	1	—
		1	10 dBm			
DA3	Transmitter Off Time (t_{OFFT})	0	2 ms	1	0	—
		1	20 ms			
DA<2:0>	Reserved	100 ⁽²⁾	—	100	100	—

- Note 1:** Actual frequency deviation value dependant on crystal frequency.
Note 2: When writing to the Application register, DA<2:0> must be 0b100.

TABLE 9-4: FREQUENCY REGISTER

Bit	Name	Value	Setting	Power-on Reset		Notes
				CTRL = 0	CTRL = 1	
DF<18:0>	Transmit Frequency (f_{TX})	—	—	0x42C1C ⁽¹⁾	0x42CAD ⁽¹⁾	Refer to Section 9.4 “Frequency Selection and Configuration”. When reading frequency, the Most Significant 3 bits are read from the STATUS register (see Table 9-5)

- Note 1:** Actual frequency value dependant on crystal frequency.

PIC12F529T39A

9.2.3 DATA TRANSMISSION

TABLE 9-5: STATUS REGISTER

Bit	Name	Value	Setting	Power-on Reset		Notes
				CTRL = 0	CTRL = 1	
DV<7:0>	Chip Version	0x11	—	0x11	0x11	0x11 = Version A1
DS<4:2>	Reserved	—	—	—	—	—
DS1	TX Ready	0	Sleep	—	—	
		1	Transmitting	—	—	
DS0	Reserved	—	—	—	—	
DF<18:16>	Transmit Frequency (f_{TX})	—	—	0b100	0b100	Refer to Section 9.4 “Frequency Selection and Configuration” . When reading frequency, the Most Significant 3 bits are read from the STATUS register (see Table 9-5)

RF data is transmitted when the DATA pin is at a logic '1' for greater than t_{WAKE} as shown in [Figure 9-5](#). The CTRL pin must remain stable (either logic '0' or '1'). If the modulation mode is OOK, the transmitted signal is turned on and off by the DATA pin. If the modulation mode is FSK, the transmitted signal is frequency shifted by the DATA pin. The encoding of the transmitted signal is determined by the length of time the DATA pin is held logic '0' or '1'.

9.2.4 SLEEP MODE

The RF transmitter will automatically enter Sleep mode when the DATA pin is a logic '0' for greater than t_{OFFT} , as shown in Figure 9-5. t_{OFFT} can be configured for 2 or 20 ms in the Application register (see Table 9-3).

FIGURE 9-5: DATA PIN TRANSMIT TIMING DIAGRAM

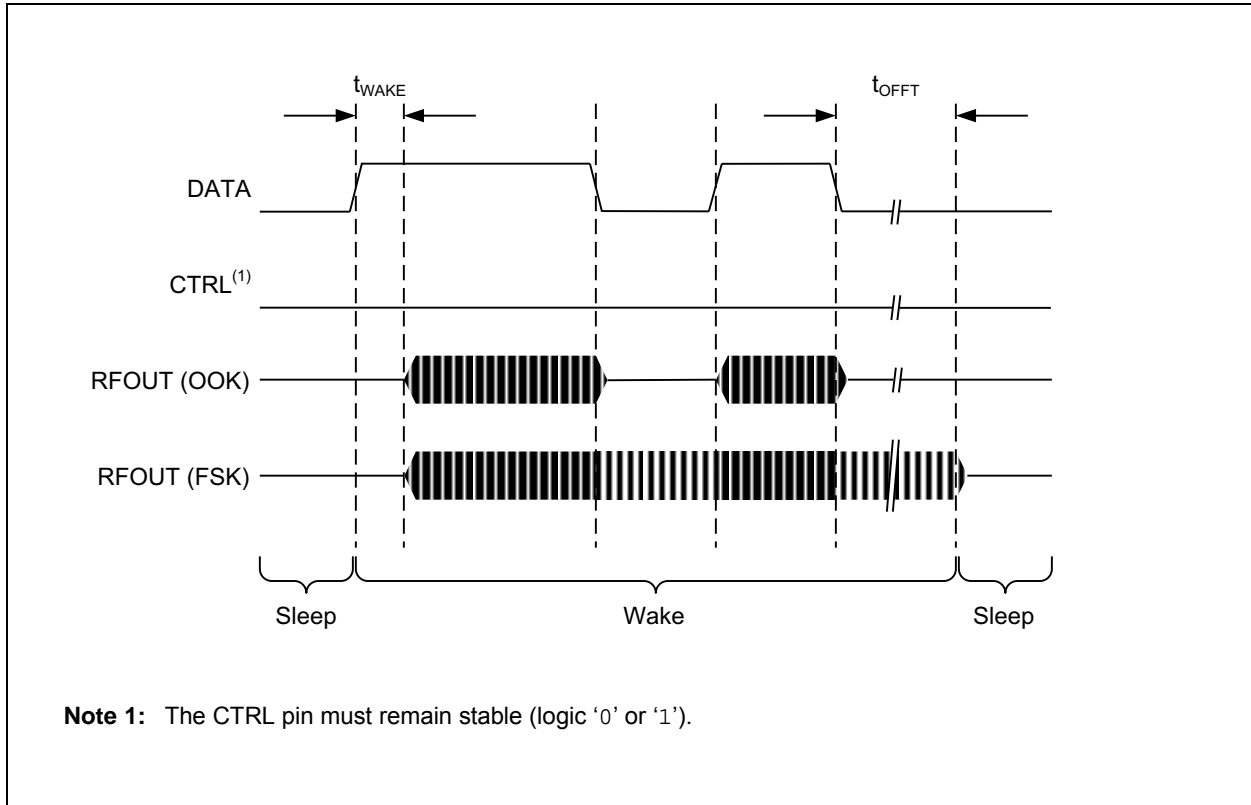

PIC12F529T39A

9.2.5 MANUAL TRANSMIT MODE

The RF transmitter can continuously transmit by setting the mode bit (DA15) to a logic '1' in the Applications register (see [Table 9-3](#)). It will continuously transmit RF data presented on the DATA pin without automatically entering Sleep mode. To cease transmission the mode bit must be cleared (DA15 = 0). [Figure 9-6](#) shows the Manual Transmit mode timing.

FIGURE 9-6: MANUAL TRANSMIT MODE TIMING

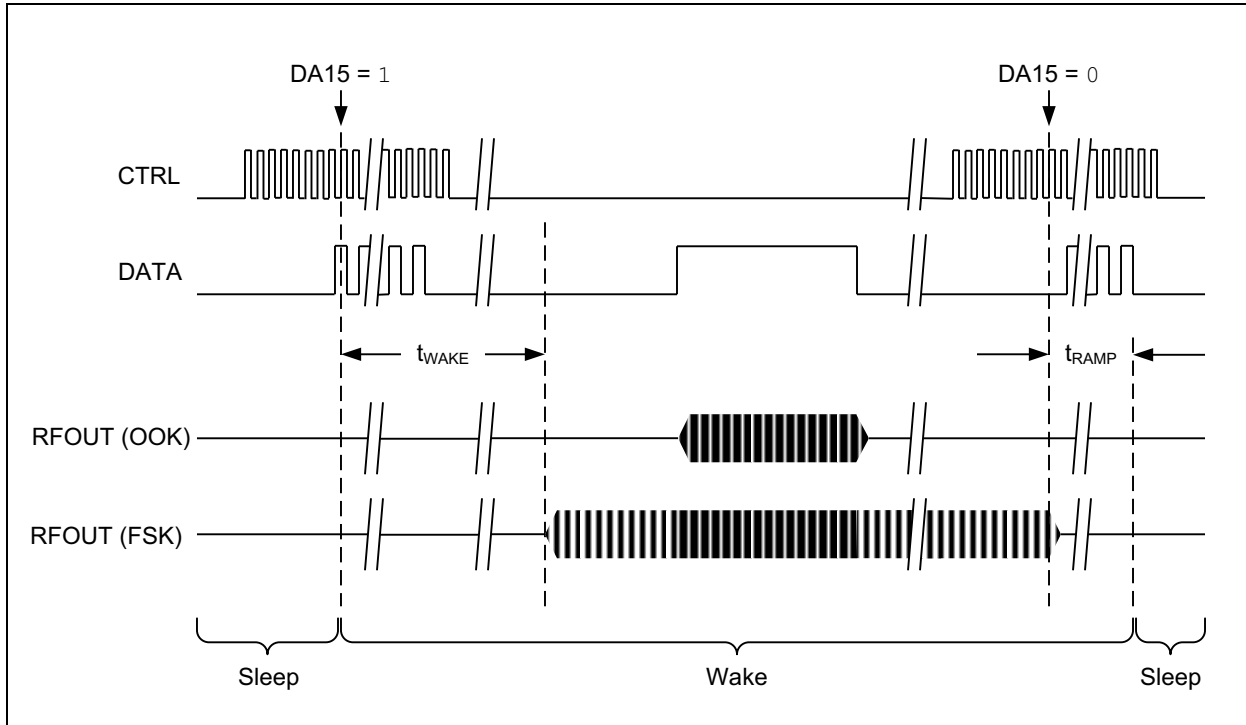

9.3 Modulation Selection

9.3.1 ON-OFF KEYING (OOK)

OOK modulation can be configured by setting the modulation DA14 bit in the Application register ([Table 9-3](#)). Data is transmitted as stated in [Section 9.2.3 "Data Transmission"](#).

9.3.2 FREQUENCY SHIFT KEYING (FSK)

FSK modulation can be configured by clearing the modulation DA14 bit in the Application register. Frequency Deviation (f_{DEV}) is configured by setting the DA<12:5> bits in the Application register. Data is transmitted as stated in [Section 9.2.3 "Data Transmission"](#).

9.3.3 DIGITAL TRANSMISSION SYSTEM (DTS)

In the United States and Canada, digital modulation techniques are permitted (FCC Part 15.247 and RSS-210, respectively). The RF transmitter can be configured for DTS mode by selecting FSK and $f_{DEV} = 200$ kHz. Data encoding techniques, such as data whitening, may be needed to ensure that the minimum 6 dB bandwidth is at least 500 kHz.

9.4 Frequency Selection and Configuration

The RF transmitter is capable of generating many of the popular RF frequencies that are permitted within the radio regulations of the country the finished product will be sold. The RF frequency configuration is performed by determining which frequency band, selecting the crystal frequency, and setting the frequency value in the Frequency register DF<18:0>. If FSK modulation is used, the frequency deviation is set in the Application register DA<12:5>. See [Section 9.2.2 “RF Transmitter Registers”](#) for information on Configuration register settings.

9.4.1 BAND SELECTION

The Band bit, DA13, in the Application register configures the RF transmitter for a range of frequencies for a given crystal frequency as shown in [Table 9-6](#).

TABLE 9-6: FREQUENCY BAND SELECTION

Band Setting DA<13>	Frequency Band (f_{RF})	Crystal Frequency (f_{XTAL})
0	310 -450 MHz	22 MHz
	312 -450 MHz	24 MHz
	338-450 MHz	26 MHz
1	863-870 MHz	22 MHz
	902-924 MHz	
	863-870 MHz	24 MHz
	902-928 MHz	26 MHz

9.4.2 CRYSTAL SELECTION

Once the frequency band has been selected, the choice of crystal frequency is flexible provided the crystal meets the specifications summarized in [Table 9-7](#), the boundaries of the Frequency register DF<18:0> are followed as shown in [Figure 9-7](#), and RF transmit frequency error is acceptable (see [Section 9.4.3 “Frequency Calculation”](#)).

TABLE 9-7: CRYSTAL RESONATOR SPECIFICATIONS

Symbol	Description	Min.	Typ.	Max.	Unit
FXTAL	Crystal Frequency	22	—	26	MHz
CL	Load Capacitance	—	15	—	pF
ESR	Equivalent Series Resistance	—	—	100	Ohms

The crystal frequency tolerance and frequency stability over the operating temperature range depends on the system frequency budget. Typically, the receiver crystal frequency tolerance, stability, and receiver bandwidth will have the greatest influence. For OOK modulation, the transmitted RF signal (f_{RF}) should remain inside the receiver bandwidth, otherwise signal degradation will occur. For FSK modulation, f_{RF} should remain inside the receiver bandwidth and within $0.5 * f_{DEV}$.

As a general practice, do not choose a RF transmit signal (f_{RF}) with an integer or near integer multiple of f_{XTAL} . This will result in higher noise and spurious emissions.

9.4.3 FREQUENCY CALCULATION

Once the frequency band and crystal frequency are selected, the RF transmit signal (f_{RF}) is calculated by setting the Frequency register DF(18:0) bits according to the formula shown in [Figure 9-7](#). If the calculated value for DF(18:0) is not an integer, there will be an associated transmit frequency error. Ensure that this error is within the acceptable system frequency budget. Similarly, the frequency deviation is calculated as shown in [Figure 9-7](#).

PIC12F529T39A

FIGURE 9-7: FREQUENCY CALCULATION

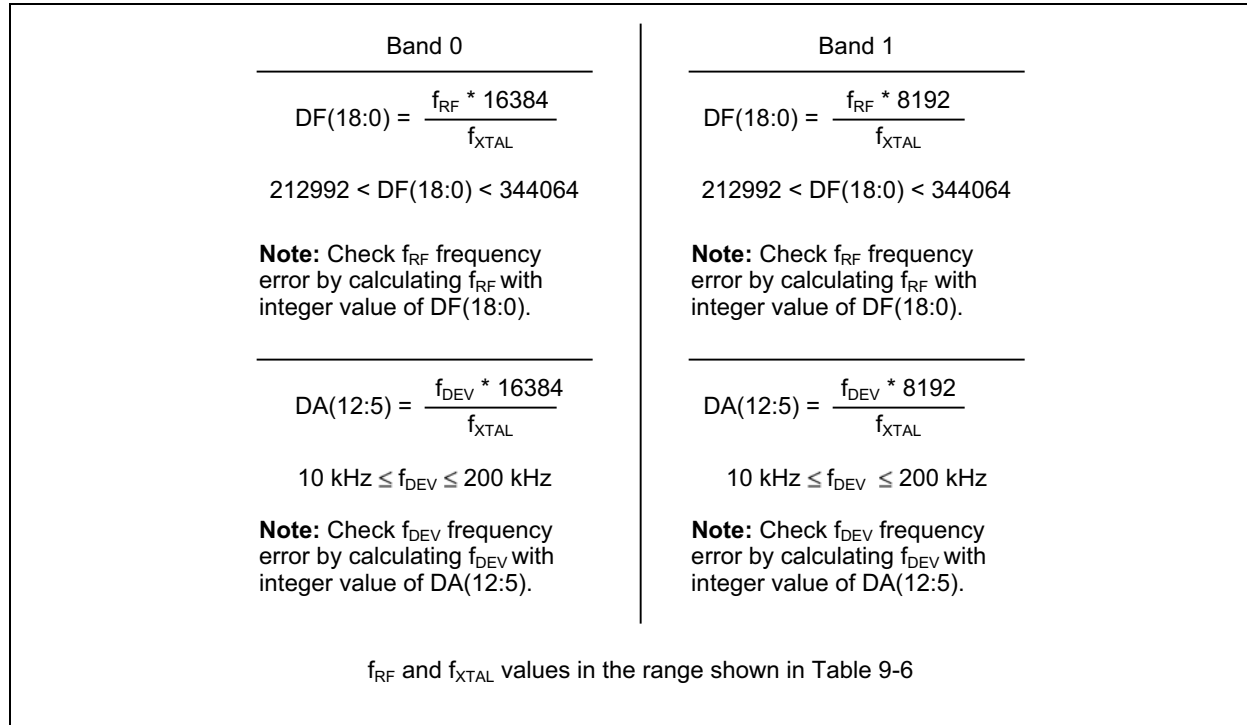

9.5 Applications

9.5.1 SOFTWARE INITIALIZATION

EXAMPLE 9-1: SAMPLE INITIALIZATION CODE

```

#define APP_REG_PREFIX 0
#define FREQ_REG_PREFIX 0x18

void sendTxCommand(unsigned char cmd)
{
    // The 'T39A samples data on the rising edge of clock. Clock is idle low.
    unsigned char i;
    for (i=0; i<8; i++)
    {
        if (cmd & 0x80)
            DATA_OUT = 1;
        else
            DATA_OUT = 0;

        CTRL_OUT = 1;
        NOP();
        NOP();
        CTRL_OUT = 0;
        cmd = cmd << 1;
    }
}

void TX_Init(void)
{
    unsigned char app_high = (T39A_APP_CONFIG & 0x00FF00) >> 8;
    unsigned char app_low  = (T39A_APP_CONFIG & 0x0000FF);

    unsigned char f_upper = (T39A_FREQ_CONFIG & 0x70000) >> 16;
    unsigned char f_high  = (T39A_FREQ_CONFIG & 0x0FF00) >> 8;
    unsigned char f_low   = (T39A_FREQ_CONFIG & 0x000FF);

    sendTxCommand(APP_REG_PREFIX);
    sendTxCommand(app_high);
    sendTxCommand(app_low);

    sendTxCommand(FREQ_REG_PREFIX | f_upper);
    sendTxCommand(f_high);
    sendTxCommand(f_low);

    return;
}

```

9.5.2 APPLICATION CIRCUIT

Figure 9-8 describes a sample four-button remote transmitter application schematic. Table 9-8 contains its bill of materials. This schematic and bill of materials is a design suggestion only. Actual component values will be dependent on implementation parameters.

FIGURE 9-8: APPLICATION SCHEMATIC

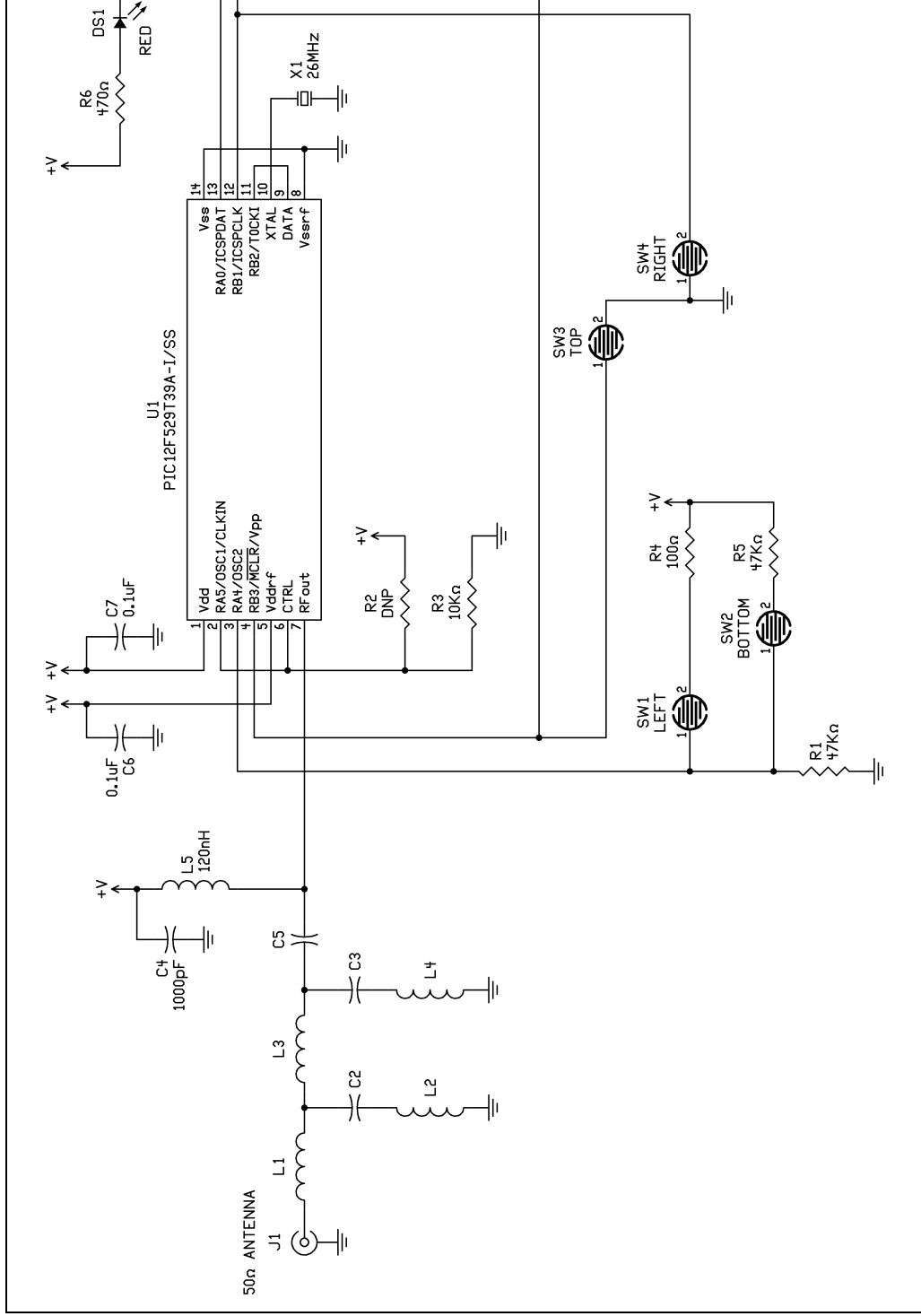

TABLE 9-8: BILL OF MATERIALS

	Designator	Value	Description
Common	U1	PIC12F529T39A	Microcontroller with integrated UHF transmitter
	C6, C7	0.1 μ F	Decoupling
	R6	470 Ω	Current limiting
	DS1	RED	LED
	R3	10 k Ω	Weak pull-down for RF configuration
	R4	100 Ω	Voltage divider
	R1, R5	47 k Ω	
	C4	1000 pF	
434 MHz	L5	120 nH	Matching to 50 Ω
	C5	100 pF	
	C3, L1, L3	0 Ω	
	L4	39 nH	
	C2	6.8 pF	
	L2	2.2 nH	
	X1	24 MHz	
868 MHz	L5	12 nH	Matching to 50 Ω
	C5	1 pF	
	C3, L4	DNP	
	L3	27 nH	
	C2	2.7 pF	
	L1, L2	0 Ω	
	X1	26 MHz	
915 MHz	L5	8.2 nH	Matching to 50 Ω
	L1, L4, C2	0 Ω	
	C5	4.7 pF	
	C3	1.2 pF	
	L3	2.4 nH	
	L2	10 nH	
	X1	26 MHz	

PIC12F529T39A

10.0 INSTRUCTION SET SUMMARY

The PIC12F529T39A instruction set is highly orthogonal and is comprised of three basic categories.

- **Byte-oriented** operations
- **Bit-oriented** operations
- **Literal and control** operations

Each PIC12F529T39A instruction is a 12-bit word divided into an **opcode**, which specifies the instruction type, and one or more **operands** which further specify the operation of the instruction. The formats for each of the categories is presented in [Figure 10-1](#), while the various opcode fields are summarized in [Table 10-1](#).

For **byte-oriented** instructions, 'f' represents a file register designator and 'd' represents a destination designator. The file register designator specifies which file register is to be used by the instruction.

The destination designator specifies where the result of the operation is to be placed. If 'd' is '0', the result is placed in the W register. If 'd' is '1', the result is placed in the file register specified in the instruction.

For **bit-oriented** instructions, 'b' represents a bit field designator which selects the number of the bit affected by the operation, while 'f' represents the number of the file in which the bit is located.

For **literal and control** operations, 'k' represents an 8 or 9-bit constant or literal value.

TABLE 10-1: OPCODE FIELD DESCRIPTIONS

Field	Description
f	Register file address (0x00 to 0x7F)
W	Working register (accumulator)
b	Bit address within an 8-bit file register
k	Literal field, constant data or label
x	Don't care location (= 0 or 1) The assembler will generate code with x = 0. It is the recommended form of use for compatibility with all Microchip software tools.
d	Destination select; d = 0 (store result in W) d = 1 (store result in file register 'f') Default is d = 1
label	Label name
TOS	Top-of-Stack
PC	Program Counter
WDT	Watchdog Timer counter
\overline{TO}	Time-out bit
\overline{PD}	Power-down bit
dest	Destination, either the W register or the specified register file location
[]	Options
()	Contents
→	Assigned to
< >	Register bit field
∈	In the set of
<i>italics</i>	User defined term (font is courier)

All instructions are executed within a single instruction cycle, unless a conditional test is true or the program counter is changed as a result of an instruction. In this case, the execution takes two instruction cycles. One instruction cycle consists of four oscillator periods. Thus, for an oscillator frequency of 4 MHz, the normal instruction execution time is 1 μs. If a conditional test is true or the program counter is changed as a result of an instruction, the instruction execution time is 2 μs.

[Figure 10-1](#) shows the three general formats that the instructions can have. All examples in the figure use the following format to represent a hexadecimal number:

0xhhh

where 'h' signifies a hexadecimal digit.

FIGURE 10-1: GENERAL FORMAT FOR INSTRUCTIONS

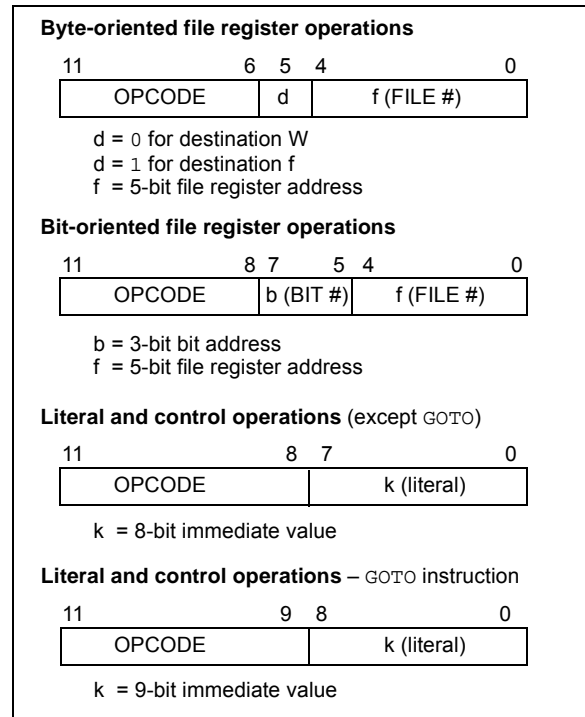

TABLE 10-2: INSTRUCTION SET SUMMARY

Mnemonic, Operands	Description	Cycles	12-Bit Opcode		Status Affected	Notes
			MSb	LSb		
ADDWF f, d	Add W and f	1	0001	11df ffff	C, DC, Z	1, 2, 4
ANDWF f, d	AND W with f	1	0001	01df ffff	Z	2, 4
CLRF f	Clear f	1	0000	011f ffff	Z	4
CLRW –	Clear W	1	0000	0100 0000	Z	
COMF f, d	Complement f	1	0010	01df ffff	Z	
DECF f, d	Decrement f	1	0000	11df ffff	Z	2, 4
DECFSZ f, d	Decrement f, Skip if 0	1(2)	0010	11df ffff	None	2, 4
INCF f, d	Increment f	1	0010	10df ffff	Z	2, 4
INCFSZ f, d	Increment f, Skip if 0	1(2)	0011	11df ffff	None	2, 4
IORWF f, d	Inclusive OR W with f	1	0001	00df ffff	Z	2, 4
MOVF f, d	Move f	1	0010	00df ffff	Z	2, 4
MOVWF f	Move W to f	1	0000	001f ffff	None	1, 4
NOP –	No Operation	1	0000	0000 0000	None	
RLF f, d	Rotate left f through Carry	1	0011	01df ffff	C	2, 4
RRF f, d	Rotate right f through Carry	1	0011	00df ffff	C	2, 4
SUBWF f, d	Subtract W from f	1	0000	10df ffff	C, DC, Z	1, 2, 4
SWAPF f, d	Swap f	1	0011	10df ffff	None	2, 4
XORWF f, d	Exclusive OR W with f	1	0001	10df ffff	Z	2, 4
BIT-ORIENTED FILE REGISTER OPERATIONS						
BCF f, b	Bit Clear f	1	0100	bbbbf ffff	None	2, 4
BSF f, b	Bit Set f	1	0101	bbbbf ffff	None	2, 4
BTFSC f, b	Bit Test f, Skip if Clear	1(2)	0110	bbbbf ffff	None	
BTFSS f, b	Bit Test f, Skip if Set	1(2)	0111	bbbbf ffff	None	
LITERAL AND CONTROL OPERATIONS						
ANDLW k	AND literal with W	1	1110	kkkk kkkk	Z	
CALL k	Call Subroutine	2	1001	kkkk kkkk	None	1
CLRWDT –	Clear Watchdog Timer	1	0000	0000 0100	TO, PD	
GOTO k	Unconditional branch	2	101k	kkkk kkkk	None	
IORLW k	Inclusive OR literal with W	1	1101	kkkk kkkk	Z	
MOVLW k	Move literal to W	1	1100	kkkk kkkk	None	
MOVLB k	Move literal to BSR	1	0000	0001 0kkk	None	
OPTION –	Load OPTION register	1	0000	0000 0010	None	
RETLW k	Return, place literal in W	2	1000	kkkk kkkk	None	
SLEEP –	Go into Standby mode	1	0000	0000 0011	TO, PD	3
TRIS f	Load TRISGPIO register	1	0000	0000 0fff	None	
XORLW k	Exclusive OR literal to W	1	1111	kkkk kkkk	Z	

Note 1: The 9th bit of the program counter will be forced to a '0' by any instruction that writes to the PC except for GOTO. See [Section 4.6 "Program Counter"](#).

- When an I/O register is modified as a function of itself (e.g. `MOVF GPIO, 1`), the value used will be that value present on the pins themselves. For example, if the data latch is '1' for a pin configured as input and is driven low by an external device, the data will be written back with a '0'.
- The instruction `TRIS f`, where `f = 6`, causes the contents of the W register to be written to the tri-state latches of GPIO. A '1' forces the pin to a high-impedance state and disables the output buffers.
- If this instruction is executed on the TMR0 register (and, where applicable, `d = 1`), the prescaler will be cleared (if assigned to TMR0).

PIC12F529T39A

ADDWF **Add W and f**

Syntax: [*label*] ADDWF f,d
Operands: $0 \leq f \leq 31$
 $d \in [0,1]$
Operation: (W) + (f) → (dest)
Status Affected: C, DC, Z
Description: Add the contents of the W register and register 'f'. If 'd' is '0', the result is stored in the W register. If 'd' is '1', the result is stored back in register 'f'.

ANDLW **AND literal with W**

Syntax: [*label*] ANDLW k
Operands: $0 \leq k \leq 255$
Operation: (W).AND. (k) → (W)
Status Affected: Z
Description: The contents of the W register are AND'ed with the 8-bit literal 'k'. The result is placed in the W register.

ANDWF **AND W with f**

Syntax: [*label*] ANDWF f,d
Operands: $0 \leq f \leq 31$
 $d \in [0,1]$
Operation: (W) .AND. (f) → (dest)
Status Affected: Z
Description: The contents of the W register are AND'ed with register 'f'. If 'd' is '0', the result is stored in the W register. If 'd' is '1', the result is stored back in register 'f'.

BCF **Bit Clear f**

Syntax: [*label*] BCF f,b
Operands: $0 \leq f \leq 31$
 $0 \leq b \leq 7$
Operation: $0 \rightarrow (f)$
Status Affected: None
Description: Bit 'b' in register 'f' is cleared.

BSF **Bit Set f**

Syntax: [*label*] BSF f,b
Operands: $0 \leq f \leq 31$
 $0 \leq b \leq 7$
Operation: $1 \rightarrow (f)$
Status Affected: None
Description: Bit 'b' in register 'f' is set.

BTFSC **Bit Test f, Skip if Clear**

Syntax: [*label*] BTFSC f,b
Operands: $0 \leq f \leq 31$
 $0 \leq b \leq 7$
Operation: skip if (f) = 0
Status Affected: None
Description: If bit 'b' in register 'f' is '0', then the next instruction is skipped.
 If bit 'b' is '0', then the next instruction fetched during the current instruction execution is discarded, and a NOP is executed instead, making this a 2-cycle instruction.

BTFSS	Bit Test f, Skip if Set
Syntax:	[<i>label</i>] BTFSS f,b
Operands:	$0 \leq f \leq 31$ $0 \leq b < 7$
Operation:	skip if (f) = 1
Status Affected:	None
Description:	If bit 'b' in register 'f' is '1', then the next instruction is skipped. If bit 'b' is '1', then the next instruction fetched during the current instruction execution, is discarded and a NOP is executed instead, making this a 2-cycle instruction.

CLRW	Clear W
Syntax:	[<i>label</i>] CLRW
Operands:	None
Operation:	00h → (W); 1 → Z
Status Affected:	Z
Description:	The W register is cleared. Zero bit (Z) is set.

CALL	Subroutine Call
Syntax:	[<i>label</i>] CALL k
Operands:	$0 \leq k \leq 255$
Operation:	(PC) + 1 → Top-of-Stack; k → PC<7:0>; (STATUS<6:5>) → PC<10:9>; 0 → PC<8>
Status Affected:	None
Description:	Subroutine call. First, return address (PC + 1) is pushed onto the stack. The 8-bit immediate address is loaded into PC bits <7:0>. The upper bits PC<10:9> are loaded from STATUS<6:5>, PC<8> is cleared. CALL is a 2-cycle instruction.

CLRWDT	Clear Watchdog Timer
Syntax:	[<i>label</i>] CLRWDT
Operands:	None
Operation:	00h → WDT; 0 → WDT prescaler (if assigned); 1 → \overline{TO} ; 1 → PD
Status Affected:	\overline{TO} , PD
Description:	The CLRWDT instruction resets the WDT. It also resets the prescaler, if the prescaler is assigned to the WDT and not Timer0. Status bits \overline{TO} and PD are set.

CLRF	Clear f
Syntax:	[<i>label</i>] CLRF f
Operands:	$0 \leq f \leq 31$
Operation:	00h → (f); 1 → Z
Status Affected:	Z
Description:	The contents of register 'f' are cleared and the Z bit is set.

COMF	Complement f
Syntax:	[<i>label</i>] COMF f,d
Operands:	$0 \leq f \leq 31$ d ∈ [0,1]
Operation:	(f) → (dest)
Status Affected:	Z
Description:	The contents of register 'f' are complemented. If 'd' is '0', the result is stored in the W register. If 'd' is '1', the result is stored back in register 'f'.

PIC12F529T39A

DECf **Decrement f**

Syntax: [*label*] DECf f,d

Operands: $0 \leq f \leq 31$
 $d \in [0,1]$

Operation: $(f) - 1 \rightarrow (\text{dest})$

Status Affected: Z

Description: Decrement register 'f'. If 'd' is '0', the result is stored in the W register. If 'd' is '1', the result is stored back in register 'f'.

INCF **Increment f**

Syntax: [*label*] INCF f,d

Operands: $0 \leq f \leq 31$
 $d \in [0,1]$

Operation: $(f) + 1 \rightarrow (\text{dest})$

Status Affected: Z

Description: The contents of register 'f' are incremented. If 'd' is '0', the result is placed in the W register. If 'd' is '1', the result is placed back in register 'f'.

DECFSZ **Decrement f, Skip if 0**

Syntax: [*label*] DECFSZ f,d

Operands: $0 \leq f \leq 31$
 $d \in [0,1]$

Operation: $(f) - 1 \rightarrow d$; skip if result = 0

Status Affected: None

Description: The contents of register 'f' are decremented. If 'd' is '0', the result is placed in the W register. If 'd' is '1', the result is placed back in register 'f'.

If the result is '0', the next instruction, which is already fetched, is discarded and a NOP is executed instead making it a 2-cycle instruction.

INCFSZ **Increment f, Skip if 0**

Syntax: [*label*] INCFSZ f,d

Operands: $0 \leq f \leq 31$
 $d \in [0,1]$

Operation: $(f) + 1 \rightarrow (\text{dest})$, skip if result = 0

Status Affected: None

Description: The contents of register 'f' are incremented. If 'd' is '0', the result is placed in the W register. If 'd' is '1', the result is placed back in register 'f'.

If the result is '0', then the next instruction, which is already fetched, is discarded and a NOP is executed instead making it a 2-cycle instruction.

GOTO **Unconditional Branch**

Syntax: [*label*] GOTO k

Operands: $0 \leq k \leq 511$

Operation: $k \rightarrow \text{PC}<8:0>$;
 $\text{STATUS}<6:5> \rightarrow \text{PC}<10:9>$

Status Affected: None

Description: GOTO is an unconditional branch. The 9-bit immediate value is loaded into PC bits <8:0>. The upper bits of PC are loaded from STATUS<6:5>. GOTO is a 2-cycle instruction.

IORLW **Inclusive OR literal with W**

Syntax: [*label*] IORLW k

Operands: $0 \leq k \leq 255$

Operation: $(W) .\text{OR. } (k) \rightarrow (W)$

Status Affected: Z

Description: The contents of the W register are OR'ed with the 8-bit literal 'k'. The result is placed in the W register.

IORWF **Inclusive OR W with f**

Syntax: [*label*] IORWF f,d

Operands: $0 \leq f \leq 31$
 $d \in [0,1]$

Operation: (W).OR. (f) → (dest)

Status Affected: Z

Description: Inclusive OR the W register with register 'f'. If 'd' is '0', the result is placed in the W register. If 'd' is '1', the result is placed back in register 'f'.

MOVWF **Move W to f**

Syntax: [*label*] MOVWF f

Operands: $0 \leq f \leq 31$

Operation: (W) → (f)

Status Affected: None

Description: Move data from the W register to register 'f'.

MOVF **Move f**

Syntax: [*label*] MOVF f,d

Operands: $0 \leq f \leq 31$
 $d \in [0,1]$

Operation: (f) → (dest)

Status Affected: Z

Description: The contents of register 'f' are moved to destination 'd'. If 'd' is '0', destination is the W register. If 'd' is '1', the destination is file register 'f'. 'd' = 1 is useful as a test of a file register, since status flag Z is affected.

NOP **No Operation**

Syntax: [*label*] NOP

Operands: None

Operation: No operation

Status Affected: None

Description: No operation.

MOVLB **Move literal to BSR**

Syntax: [*label*] MOVLB k

Operands: $0 \leq k \leq 7$

Operation: $k \rightarrow \text{BSR}$

Status Affected: None

Description: The 3-bit literal 'k' is loaded into the Bank Select Register (BSR). The "don't cares" will be assembled at '0'.

OPTION **Load OPTION Register**

Syntax: [*label*] OPTION

Operands: None

Operation: (W) → Option

Status Affected: None

Description: The content of the W register is loaded into the OPTION register.

MOVLW **Move Literal to W**

Syntax: [*label*] MOVLW k

Operands: $0 \leq k \leq 255$

Operation: $k \rightarrow (W)$

Status Affected: None

Description: The 8-bit literal 'k' is loaded into the W register. The "don't cares" will be assembled as '0's.

PIC12F529T39A

RETLW **Return with Literal in W**

Syntax: [*label*] RETLW *k*

Operands: $0 \leq k \leq 255$

Operation: $k \rightarrow (W)$;
 TOS \rightarrow PC

Status Affected: None

Description: The W register is loaded with the 8-bit literal 'k'. The program counter is loaded from the top of the stack (the return address). This is a 2-cycle instruction.

SLEEP **Enter SLEEP Mode**

Syntax: [*label*] SLEEP

Operands: None

Operation: 00h \rightarrow WDT;
 0 \rightarrow WDT prescaler;
 1 \rightarrow \overline{TO} ;
 0 \rightarrow PD

Status Affected: \overline{TO} , PD, GPWUF

Description: Time-out Status bit (\overline{TO}) is set. The Power-down Status bit (PD) is cleared. GPWUF is unaffected. The WDT and its prescaler are cleared. The processor is put into Sleep mode with the oscillator stopped. See [Section 8.8 "Power-down Mode \(Sleep\)"](#) on Sleep for more details.

RLF **Rotate Left f through Carry**

Syntax: [*label*] RLF *f,d*

Operands: $0 \leq f \leq 31$
 $d \in [0,1]$

Operation: See description below

Status Affected: C

Description: The contents of register 'f' are rotated one bit to the left through the Carry flag. If 'd' is '0', the result is placed in the W register. If 'd' is '1', the result is stored back in register 'f'.

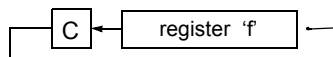

SUBWF **Subtract W from f**

Syntax: [*label*] SUBWF *f,d*

Operands: $0 \leq f \leq 31$
 $d \in [0,1]$

Operation: $(f) - (W) \rightarrow (dest)$

Status Affected: C, DC, Z

Description: Subtract (two's complement method) the W register from register 'f'. If 'd' is '0', the result is stored in the W register. If 'd' is '1', the result is stored back in register 'f'.

RRF **Rotate Right f through Carry**

Syntax: [*label*] RRF *f,d*

Operands: $0 \leq f \leq 31$
 $d \in [0,1]$

Operation: See description below

Status Affected: C

Description: The contents of register 'f' are rotated one bit to the right through the Carry flag. If 'd' is '0', the result is placed in the W register. If 'd' is '1', the result is placed back in register 'f'.

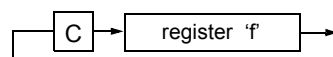

SWAPF **Swap Nibbles in f**

Syntax: [*label*] SWAPF *f,d*

Operands: $0 \leq f \leq 31$
 $d \in [0,1]$

Operation: $(f<3:0>) \rightarrow (dest<7:4>)$;
 $(f<7:4>) \rightarrow (dest<3:0>)$

Status Affected: None

Description: The upper and lower nibbles of register 'f' are exchanged. If 'd' is '0', the result is placed in W register. If 'd' is '1', the result is placed in register 'f'.

TRIS **Load TRIS Register**

Syntax: [*label*] TRIS *f*
Operands: *f* = 6
Operation: (*W*) → TRIS register *f*
Status Affected: None
Description: TRIS register '*f*' (*f* = 6 or 7) is loaded with the contents of the *W* register.

XORLW **Exclusive OR literal with W**

Syntax: [*label*] XORLW *k*
Operands: $0 \leq k \leq 255$
Operation: (*W*) .XOR. *k* → (*W*)
Status Affected: *Z*
Description: The contents of the *W* register are XOR'ed with the 8-bit literal '*k*'. The result is placed in the *W* register.

XORWF **Exclusive OR W with f**

Syntax: [*label*] XORWF *f,d*
Operands: $0 \leq f \leq 31$
 $d \in [0,1]$
Operation: (*W*) .XOR. (*f*) → (*dest*)
Status Affected: *Z*
Description: Exclusive OR the contents of the *W* register with register '*f*'. If '*d*' is '0', the result is stored in the *W* register. If '*d*' is '1', the result is stored back in register '*f*'.

11.0 DEVELOPMENT SUPPORT

The PIC[®] microcontrollers (MCU) and dsPIC[®] digital signal controllers (DSC) are supported with a full range of software and hardware development tools:

- Integrated Development Environment
 - MPLAB[®] X IDE Software
- Compilers/Assemblers/Linkers
 - MPLAB XC Compiler
 - MPASM[™] Assembler
 - MPLINK[™] Object Linker/
MPLIB[™] Object Librarian
 - MPLAB Assembler/Linker/Librarian for
Various Device Families
- Simulators
 - MPLAB X SIM Software Simulator
- Emulators
 - MPLAB REAL ICE[™] In-Circuit Emulator
- In-Circuit Debuggers/Programmers
 - MPLAB ICD 3
 - PICKit[™] 3
- Device Programmers
 - MPLAB PM3 Device Programmer
- Low-Cost Demonstration/Development Boards,
Evaluation Kits and Starter Kits
- Third-party development tools

11.1 MPLAB X Integrated Development Environment Software

The MPLAB X IDE is a single, unified graphical user interface for Microchip and third-party software, and hardware development tool that runs on Windows[®], Linux and Mac OS[®] X. Based on the NetBeans IDE, MPLAB X IDE is an entirely new IDE with a host of free software components and plug-ins for high-performance application development and debugging. Moving between tools and upgrading from software simulators to hardware debugging and programming tools is simple with the seamless user interface.

With complete project management, visual call graphs, a configurable watch window and a feature-rich editor that includes code completion and context menus, MPLAB X IDE is flexible and friendly enough for new users. With the ability to support multiple tools on multiple projects with simultaneous debugging, MPLAB X IDE is also suitable for the needs of experienced users.

Feature-Rich Editor:

- Color syntax highlighting
- Smart code completion makes suggestions and provides hints as you type
- Automatic code formatting based on user-defined rules
- Live parsing

User-Friendly, Customizable Interface:

- Fully customizable interface: toolbars, toolbar buttons, windows, window placement, etc.
- Call graph window

Project-Based Workspaces:

- Multiple projects
- Multiple tools
- Multiple configurations
- Simultaneous debugging sessions

File History and Bug Tracking:

- Local file history feature
- Built-in support for Bugzilla issue tracker

11.2 MPLAB XC Compilers

The MPLAB XC Compilers are complete ANSI C compilers for all of Microchip's 8, 16, and 32-bit MCU and DSC devices. These compilers provide powerful integration capabilities, superior code optimization and ease of use. MPLAB XC Compilers run on Windows, Linux or MAC OS X.

For easy source level debugging, the compilers provide debug information that is optimized to the MPLAB X IDE.

The free MPLAB XC Compiler editions support all devices and commands, with no time or memory restrictions, and offer sufficient code optimization for most applications.

MPLAB XC Compilers include an assembler, linker and utilities. The assembler generates relocatable object files that can then be archived or linked with other relocatable object files and archives to create an executable file. MPLAB XC Compiler uses the assembler to produce its object file. Notable features of the assembler include:

- Support for the entire device instruction set
- Support for fixed-point and floating-point data
- Command-line interface
- Rich directive set
- Flexible macro language
- MPLAB X IDE compatibility

11.3 MPASM Assembler

The MPASM Assembler is a full-featured, universal macro assembler for PIC10/12/16/18 MCUs.

The MPASM Assembler generates relocatable object files for the MPLINK Object Linker, Intel® standard HEX files, MAP files to detail memory usage and symbol reference, absolute LST files that contain source lines and generated machine code, and COFF files for debugging.

The MPASM Assembler features include:

- Integration into MPLAB X IDE projects
- User-defined macros to streamline assembly code
- Conditional assembly for multipurpose source files
- Directives that allow complete control over the assembly process

11.4 MPLINK Object Linker/ MPLIB Object Librarian

The MPLINK Object Linker combines relocatable objects created by the MPASM Assembler. It can link relocatable objects from precompiled libraries, using directives from a linker script.

The MPLIB Object Librarian manages the creation and modification of library files of precompiled code. When a routine from a library is called from a source file, only the modules that contain that routine will be linked in with the application. This allows large libraries to be used efficiently in many different applications.

The object linker/librarian features include:

- Efficient linking of single libraries instead of many smaller files
- Enhanced code maintainability by grouping related modules together
- Flexible creation of libraries with easy module listing, replacement, deletion and extraction

11.5 MPLAB Assembler, Linker and Librarian for Various Device Families

MPLAB Assembler produces relocatable machine code from symbolic assembly language for PIC24, PIC32 and dsPIC DSC devices. MPLAB XC Compiler uses the assembler to produce its object file. The assembler generates relocatable object files that can then be archived or linked with other relocatable object files and archives to create an executable file. Notable features of the assembler include:

- Support for the entire device instruction set
- Support for fixed-point and floating-point data
- Command-line interface
- Rich directive set
- Flexible macro language
- MPLAB X IDE compatibility

11.6 MPLAB X SIM Software Simulator

The MPLAB X SIM Software Simulator allows code development in a PC-hosted environment by simulating the PIC MCUs and dsPIC DSCs on an instruction level. On any given instruction, the data areas can be examined or modified and stimuli can be applied from a comprehensive stimulus controller. Registers can be logged to files for further run-time analysis. The trace buffer and logic analyzer display extend the power of the simulator to record and track program execution, actions on I/O, most peripherals and internal registers.

The MPLAB X SIM Software Simulator fully supports symbolic debugging using the MPLAB XC Compilers, and the MPASM and MPLAB Assemblers. The software simulator offers the flexibility to develop and debug code outside of the hardware laboratory environment, making it an excellent, economical software development tool.

11.7 MPLAB REAL ICE In-Circuit Emulator System

The MPLAB REAL ICE In-Circuit Emulator System is Microchip's next generation high-speed emulator for Microchip Flash DSC and MCU devices. It debugs and programs all 8, 16 and 32-bit MCU, and DSC devices with the easy-to-use, powerful graphical user interface of the MPLAB X IDE.

The emulator is connected to the design engineer's PC using a high-speed USB 2.0 interface and is connected to the target with either a connector compatible with in-circuit debugger systems (RJ-11) or with the new high-speed, noise tolerant, Low-Voltage Differential Signal (LVDS) interconnection (CAT5).

The emulator is field upgradable through future firmware downloads in MPLAB X IDE. MPLAB REAL ICE offers significant advantages over competitive emulators including full-speed emulation, run-time variable watches, trace analysis, complex breakpoints, logic probes, a ruggedized probe interface and long (up to three meters) interconnection cables.

11.8 MPLAB ICD 3 In-Circuit Debugger System

The MPLAB ICD 3 In-Circuit Debugger System is Microchip's most cost-effective, high-speed hardware debugger/programmer for Microchip Flash DSC and MCU devices. It debugs and programs PIC Flash microcontrollers and dsPIC DSCs with the powerful, yet easy-to-use graphical user interface of the MPLAB IDE.

The MPLAB ICD 3 In-Circuit Debugger probe is connected to the design engineer's PC using a high-speed USB 2.0 interface and is connected to the target with a connector compatible with the MPLAB ICD 2 or MPLAB REAL ICE systems (RJ-11). MPLAB ICD 3 supports all MPLAB ICD 2 headers.

11.9 PICkit 3 In-Circuit Debugger/Programmer

The MPLAB PICkit 3 allows debugging and programming of PIC and dsPIC Flash microcontrollers at a most affordable price point using the powerful graphical user interface of the MPLAB IDE. The MPLAB PICkit 3 is connected to the design engineer's PC using a full-speed USB interface and can be connected to the target via a Microchip debug (RJ-11) connector (compatible with MPLAB ICD 3 and MPLAB REAL ICE). The connector uses two device I/O pins and the Reset line to implement in-circuit debugging and In-Circuit Serial Programming™ (ICSP™).

11.10 MPLAB PM3 Device Programmer

The MPLAB PM3 Device Programmer is a universal, CE compliant device programmer with programmable voltage verification at VDDMIN and VDDMAX for maximum reliability. It features a large LCD display (128 x 64) for menus and error messages, and a modular, detachable socket assembly to support various package types. The ICSP cable assembly is included as a standard item. In Stand-Alone mode, the MPLAB PM3 Device Programmer can read, verify and program PIC devices without a PC connection. It can also set code protection in this mode. The MPLAB PM3 connects to the host PC via an RS-232 or USB cable. The MPLAB PM3 has high-speed communications and optimized algorithms for quick programming of large memory devices, and incorporates an MMC card for file storage and data applications.

11.11 Demonstration/Development Boards, Evaluation Kits, and Starter Kits

A wide variety of demonstration, development and evaluation boards for various PIC MCUs and dsPIC DSCs allows quick application development on fully functional systems. Most boards include prototyping areas for adding custom circuitry and provide application firmware and source code for examination and modification.

The boards support a variety of features, including LEDs, temperature sensors, switches, speakers, RS-232 interfaces, LCD displays, potentiometers and additional EEPROM memory.

The demonstration and development boards can be used in teaching environments, for prototyping custom circuits and for learning about various microcontroller applications.

In addition to the PICDEM™ and dsPICDEM™ demonstration/development board series of circuits, Microchip has a line of evaluation kits and demonstration software for analog filter design, KEELOQ® security ICs, CAN, IrDA®, PowerSmart battery management, SEEVAL® evaluation system, Sigma-Delta ADC, flow rate sensing, plus many more.

Also available are starter kits that contain everything needed to experience the specified device. This usually includes a single application and debug capability, all on one board.

Check the Microchip web page (www.microchip.com) for the complete list of demonstration, development and evaluation kits.

11.12 Third-Party Development Tools

Microchip also offers a great collection of tools from third-party vendors. These tools are carefully selected to offer good value and unique functionality.

- Device Programmers and Gang Programmers from companies, such as SoftLog and CCS
- Software Tools from companies, such as Gimpel and Trace Systems
- Protocol Analyzers from companies, such as Saleae and Total Phase
- Demonstration Boards from companies, such as MikroElektronika, Digilent® and Olimex
- Embedded Ethernet Solutions from companies, such as EZ Web Lynx, WIZnet and IPLogika®

PIC12F529T39A

12.0 ELECTRICAL CHARACTERISTICS

Absolute Maximum Ratings^(†)

Ambient temperature under bias	-40°C to +85°C
Storage temperature	-55°C to +150°C
Voltage on VDD with respect to VSS	0 to +6.5V
Voltage on VDDRF with respect to VSSRF	0 to +3.9V
Voltage on MCLR with respect to VSS	0 to +13.5V
Voltage on all other pins with respect to VSS	-0.3V to (VDD + 0.3V)
Total power dissipation ⁽¹⁾	700 mW
Max. current out of VSS pin	200 mA
Max. current into VDD pin	150 mA
Input clamp current, I _{IK} (V _I < 0 or V _I > V _{DD})	±20 mA
Output clamp current, I _{OK} (V _O < 0 or V _O > V _{DD})	±20 mA
Max. output current sunk by any I/O pin	25 mA
Max. output current sourced by any I/O pin	25 mA
Max. output current sourced by I/O port	75 mA
Max. output current sunk by I/O port	75 mA

Note 1: Power dissipation is calculated as follows: $P_{DIS} = V_{DD} \times \{I_{DD} - \sum I_{OH}\} + \sum \{(V_{DD} - V_{OH}) \times I_{OH}\} + \sum (V_{OL} \times I_{OL})$

[†]NOTICE: Stresses above those listed under “Absolute Maximum Ratings” may cause permanent damage to the device. This is a stress rating only and functional operation of the device at those or any other conditions above those indicated in the operation listings of this specification is not implied. Exposure to maximum rating conditions for extended periods may affect device reliability.

12.1 RF Transmitter Electrical Specifications

Symbol	Description	Conditions	Min.	Typ.	Max.	Unit
Current Consumption						
IDDSL	Supply Current in Sleep mode	—	—	0.5	1	μA
IDDT_315	Supply Current in Transmit mode at 315 MHz*	RFOP = +10 dBm 50% OOK	—	11	—	mA
		RFOP = +10 dBm FSK	—	15	—	mA
		RFOP = 0 dBm FSK	—	9	—	mA
IDDT_915	Supply Current in Transmit mode at 915 MHz*	RFOP = +10 dBm FSK	—	17.5	—	mA
		RFOP = 0 dBm FSK	—	10.5	—	mA
RF and Baseband Specifications						
FBAND	Accessible Frequency Bands See details in Table 7	Band 0, with FXOSC = 22 MHz	310	—	450	MHz
		Band 0, with FXOSC = 24 MHz	312	—	450	MHz
		Band 0, with FXOSC = 26 MHz	338	—	450	MHz
		Band 1, with FXOSC = 26 MHz	860 902	— —	870 928	MHz MHz
FDA	Frequency deviation, FSK	—	10	—	200	kHz
BRF	Bit rate, FSK	Permissible Range	0.5	—	100	kbps
BRO	Bit rate, OOK	Permissible Range	0.5	—	10	kbps
OOK_B	OOK Modulation Depth	—	—	45	—	dB
RFOP	RF output power in 50 Ohms in either frequency bands	High-Power Setting	7	10	—	dBm
		Low-Power Setting*	-3	0	—	dBm
RFOPFL	RF output power flatness	From 315 to 390 MHz	—	2	—	dB
DRFOPV	Variation in RF output power with supply voltage	2.5V to 3.3V	—	—	3	dB
		1.8V to 3.7V	—	—	7	dB
PHN	Transmitter phase noise	At offset: 100 kHz	—	-82	-76	dBc/Hz
		350 kHz	—	-92	-81	dBc/Hz
		550 kHz	—	-96	-91	dBc/Hz
		1.15 MHz	—	-103	-101	dBc/Hz
STEP_22	RF frequency step	FXOSC = 22 MHz, Band 0	—	1.34277	—	kHz
STEP_24	RF frequency step	FXOSC = 24 MHz, Band 0	—	1.46484	—	kHz
STEP_26	RF frequency step	FXOSC = 26 MHz, Band 0	—	1.58691	—	kHz
		FXOSC = 26 MHz, Band 1	—	3.17383	—	kHz
FXOSC	Crystal Oscillator Frequency	—	—	22	—	MHz
		—	—	24	—	MHz
		—	—	26	—	MHz
Timing Specifications						
t _{WAKE}	Time from Sleep to Tx mode	XTAL dependant, with spec'd XTAL	—	650	2000	us
t _{OFFT}	Timer from Tx data activity to Sleep	Programmable	—	2	—	ms
			—	20	—	ms
t _{RAMP}	PA Ramp up and down time	—	—	20	—	us
t _{START}	Time before CTRL pin mode selection	Time from power on to sampling of CTRL	—	1	—	ms
f _{CTRL}	CTRL Clock Frequency	—	—	—	10	MHz
t _{CH}	CTRL Clock High time	—	45	—	—	ns
t _{CL}	CTRL Clock Low time	—	45	—	—	ns
t _{RISE}	CTRL Clock Rise time	—	—	—	5	ns
t _{FALL}	CTRL Clock Fall time	—	—	—	5	ns

PIC12F529T39A

12.1 RF Transmitter Electrical Specifications

Symbol	Description	Conditions	Min.	Typ.	Max.	Unit
t_{SETUP}	DATA Setup time	From DATA transition to CTRL rising edge	45	—	—	ns
t_{HOLD}	DATA Hold time	From CTRL rising edge to DATA transition	45	—	—	ns
t_0	Time at '1' on DATA during Recovery Sequence Timing	See Figure 9-4	—	—	5	ns
t_1	Time at '0' on DATA during Recovery Sequence Timing	See Figure 9-4	5	—	—	ns

TABLE 12-1: POWER CONSUMPTION IN TX MODE

Frequency Band	Conditions	Typical Current Drain
310 to 450 MHz	POUT = +10 dBm, OOK modulation with 50% duty cycle	11 mA
	POUT = +10 dBm, FSK modulation	15 mA
	POUT = 0 dBm, FSK modulation	9 mA
860 to 870 MHz	POUT = +10 dBm, FSK modulation	16.5 mA
	POUT = 0 dBm, FSK modulation	10 mA
902 to 928 MHz	POUT = +10 dBm, FSK modulation	17.5 mA
	POUT = 0 dBm, FSK modulation	10.5 mA

FIGURE 12-1: PIC12F529T39A VOLTAGE-FREQUENCY GRAPH, $-40^{\circ}\text{C} \leq T_A \leq +85^{\circ}\text{C}$

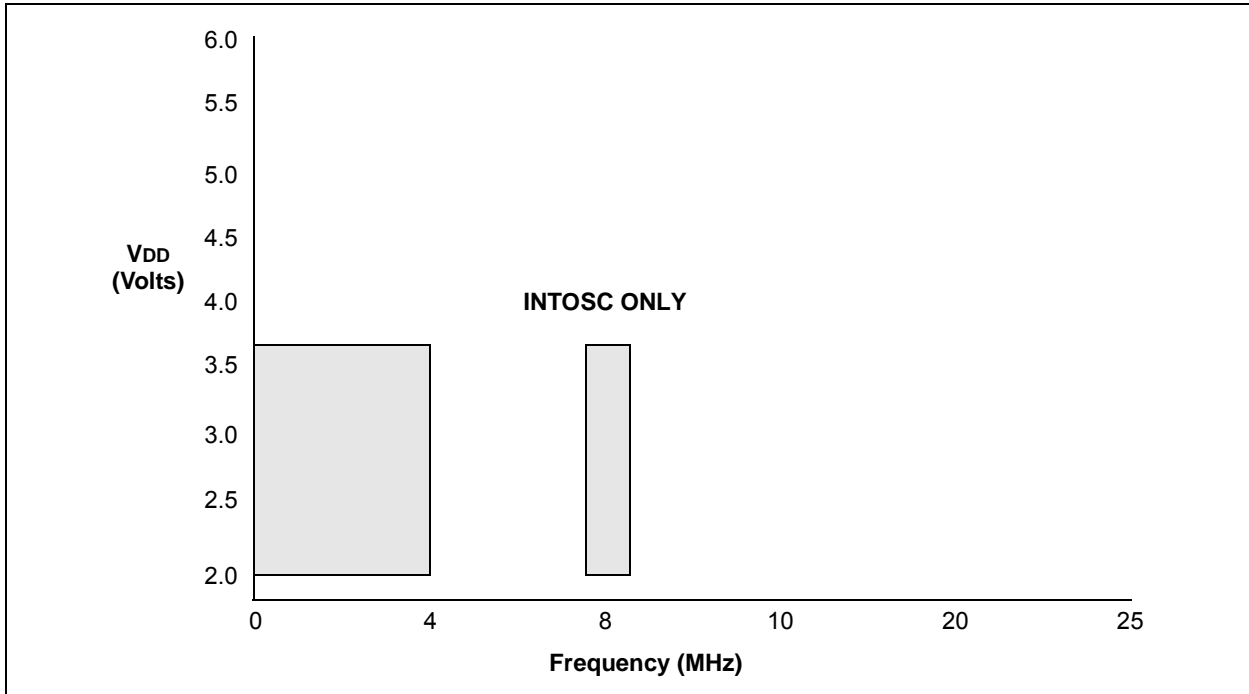
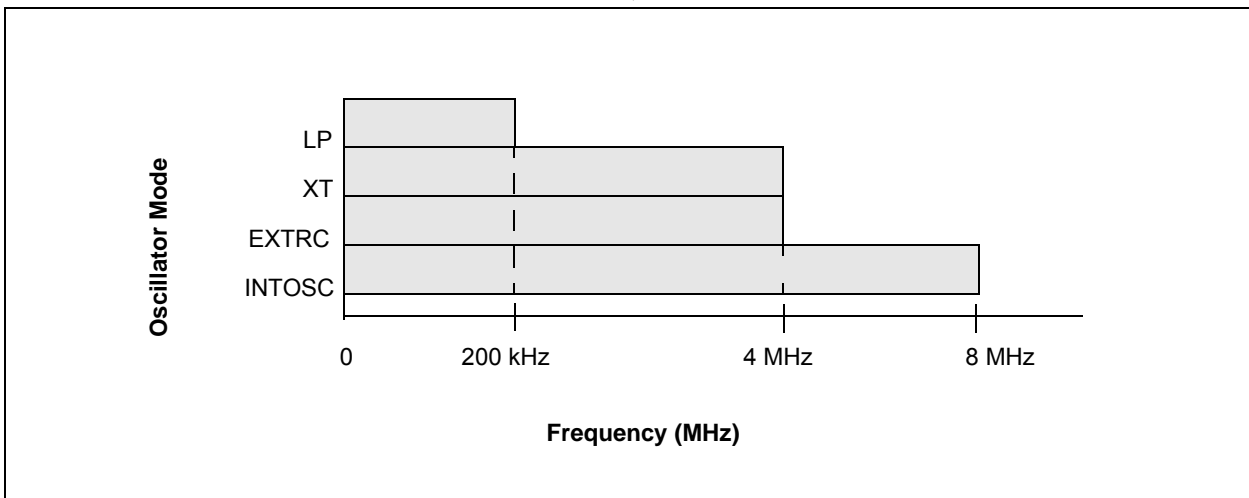

FIGURE 12-2: MAXIMUM OSCILLATOR FREQUENCY TABLE



PIC12F529T39A

12.2 DC Characteristics

TABLE 12-2: DC CHARACTERISTICS: PIC12F529T39A (INDUSTRIAL)

DC CHARACTERISTICS			Standard Operating Conditions (unless otherwise specified) Operating Temperature $-40^{\circ}\text{C} \leq T_A \leq +85^{\circ}\text{C}$ (industrial)				
Param No.	Sym.	Characteristic	Min.	Typ ⁽¹⁾	Max.	Units	Conditions
D001	VDD	Supply Voltage	2.0		3.7	V	See Figure 12-1
D002	VDR	RAM Data Retention Voltage⁽²⁾	—	1.5*	—	V	Device in Sleep mode
D003	VPOR	VDD Start Voltage to ensure Power-on Reset	—	VSS	—	V	See Section 8.4 “Power-on Reset (POR)” for details
D004	SVDD	VDD Rise Rate to ensure Power-on Reset	0.05*	—	—	V/ms	See Section 8.4 “Power-on Reset (POR)” for details
D005	IDDP	Supply Current During Prog/Erase.	—	250*	—	μA	
D010	IDD	Supply Current^(3,4)	—	175	250	μA	FOSC = 4 MHz, VDD = 2.0V
			—	250	400	μA	FOSC = 8 MHz, VDD = 2.0V
			—	11	20	μA	FOSC = 32 kHz, VDD = 2.0V
D020	IPD	Power-down Current⁽⁵⁾	—	0.1	1.2	μA	VDD = 2.0V
D022	IWDT	WDT Current	—	1.0	3.0	μA	VDD = 2.0V

* These parameters are characterized but not tested.

- Note 1:** Data in the Typical (“Typ”) column is based on characterization results at 25°C. This data is for design guidance only and is not tested.
- 2:** This is the limit to which VDD can be lowered in Sleep mode without losing RAM data.
- 3:** The supply current is mainly a function of the operating voltage and frequency. Other factors such as bus loading, oscillator type, bus rate, internal code execution pattern and temperature also have an impact on the current consumption.
- 4:** The test conditions for all IDD measurements in active operation mode are:
OSC1 = external square wave, from rail-to-rail for external clock modes; all I/O pins tri-stated, pulled to VSS, TOCKI = VDD, MCLR = VDD; WDT enabled/disabled as specified.
- 5:** For standby current measurements, the conditions are the same as IDD, except that the device is in Sleep mode. If a module current is listed, the current is for that specific module enabled and the device in Sleep.

TABLE 12-3: DC CHARACTERISTICS: PIC12F529T39A (Industrial)

DC CHARACTERISTICS		Standard Operating Conditions (unless otherwise specified) Operating temperature $-40^{\circ}\text{C} \leq T_A \leq +85^{\circ}\text{C}$ (industrial) Operating voltage V_{DD} range as described in DC specification.					
Param No.	Sym.	Characteristic	Min.	Typ†	Max.	Units	Conditions
		Input Low Voltage					
D030A	V _{IL}	I/O ports	V _{SS}	—	0.15 V _{DD}	V	Otherwise (Note 1)
D031		with Schmitt Trigger buffer	V _{SS}	—	0.15 V _{DD}	V	
D032		MCLR, T0CKI	V _{SS}	—	0.15 V _{DD}	V	
D033		OSC1 (EXTRC mode)	V _{SS}	—	0.15 V _{DD}	V	
D033A		OSC1 (XT and LP modes)	V _{SS}	—	0.3	V	
		Input High Voltage					
D040A	V _{IH}	I/O ports	0.25 V _{DD} + 0.8V	—	V _{DD}	V	Otherwise
D041		with Schmitt Trigger buffer	0.85 V _{DD}	—	V _{DD}	V	For entire V _{DD} range (Note 1)
D042		MCLR, T0CKI	0.85 V _{DD}	—	V _{DD}	V	
D042A		OSC1 (EXTRC mode)	0.85 V _{DD}	—	V _{DD}	V	
D043		OSC1 (XT and LP modes)	1.6	—	V _{DD}	V	
D070	IPUR	I/O PORT weak pull-up current⁽⁵⁾	50	250	400	μA	
		Input Leakage Current^{(2), (3)}					
D060	I _{IL}	I/O ports	—	—	±1	μA	V _{SS} ≤ V _{PIN} ≤ V _{DD} , Pin at high-impedance
D061		GP3/MCLR ⁽⁴⁾	—	±0.7	±5	μA	V _{SS} ≤ V _{PIN} ≤ V _{DD}
D063		OSC1	—	—	±5	μA	V _{SS} ≤ V _{PIN} ≤ V _{DD} , XT and LP osc configuration
		Output Low Voltage					
D080		I/O ports	—	—	0.6	V	I _{OL} = 8.5 mA, V _{DD} = 4.5V, -40°C to +85°C
		Output High Voltage					
D090		I/O ports ⁽³⁾	V _{DD} - 0.7	—	—	V	I _{OH} = -3.0 mA, V _{DD} = 4.5V, -40°C to +85°C
		Capacitive Loading Specs on Output Pins					
D101		All I/O pins	—	—	50	pF	
		Flash Data Memory					
D120	E _D	Byte endurance	100K	1M	—	E/W	-40°C ≤ T _A ≤ +85°C
D121	V _{DRW}	V _{DD} for read/write	V _{MIN}	—	3.7	V	

† Data in "Typ" column is at 5V, 25°C unless otherwise stated. These parameters are for design guidance only and are not tested.

- Note 1:** In EXTRC oscillator configuration, the OSC1/CLKIN pin is a Schmitt Trigger input. It is not recommended that the PIC12F529T39A be driven with external clock in RC mode.
- 2:** The leakage current on the MCLR pin is strongly dependent on the applied voltage level. The specified levels represent normal operating conditions. Higher leakage current may be measured at different input voltages.
- 3:** Negative current is defined as coming out of the pin.
- 4:** This specification applies to GP3/MCLR configured as GP3 with internal pull-up disabled.
- 5:** This specification applies to all weak pull-up devices, including the weak pull-up found on GP3/MCLR. The current value listed will be the same whether or not the pin is configured as GP3 with pull-up enabled or MCLR.

PIC12F529T39A

TABLE 12-4: PULL-UP RESISTOR RANGES

V _{DD} (Volts)	Temperature (°C)	Min.	Typ.	Max.	Units
GP0/GP1					
2.0	-40	73K	105K	186K	Ω
	25	73K	113K	187K	Ω
	85	82K	123K	190K	Ω
GP3					
2.0	-40	63K	81K	96K	Ω
	25	77K	93K	116K	Ω
	85	82K	96K	116K	Ω

12.3 Timing Parameter Symbology and Load Conditions – PIC12F529T39A

The timing parameter symbols have been created following one of the following formats:

1. TppS2ppS
2. TppS

T	F Frequency	T Time
----------	-------------	--------

Lowercase subscripts (pp) and their meanings:

pp	2 to	mc	$\overline{\text{MCLR}}$
	ck CLKOUT	osc	Oscillator
	cy Cycle time	os	OSC1
	drt Device Reset Timer	t0	T0CKI
	io I/O port	wdt	Watchdog Timer

Uppercase letters and their meanings:

S	F Fall	P	Period
	H High	R	Rise
	I Invalid (high-impedance)	V	Valid
	L Low	Z	High-impedance

FIGURE 12-3: LOAD CONDITIONS – PIC12F529T39A

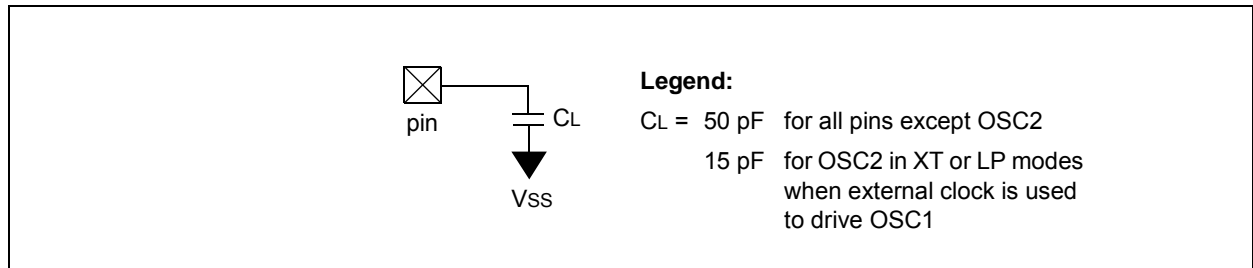
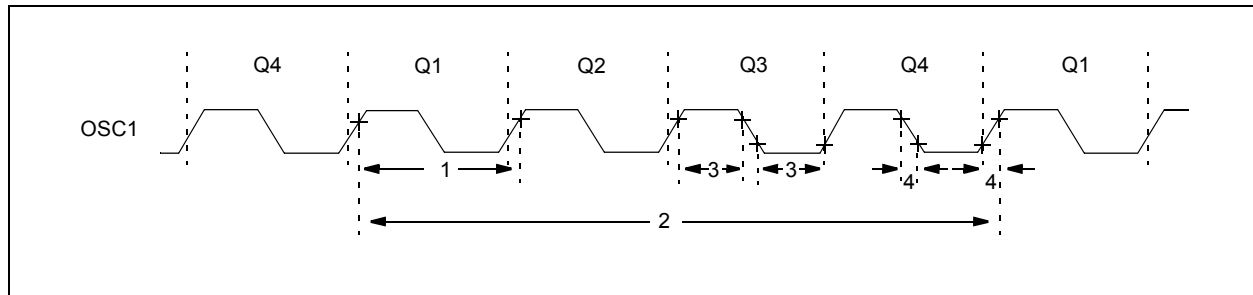

FIGURE 12-4: EXTERNAL CLOCK TIMING – PIC12F529T39A



PIC12F529T39A

12.4 AC Characteristics

TABLE 12-5: EXTERNAL CLOCK TIMING REQUIREMENTS

AC CHARACTERISTICS			Standard Operating Conditions (unless otherwise specified) Operating Temperature $-40^{\circ}\text{C} \leq T_A \leq +85^{\circ}\text{C}$ (industrial), Operating Voltage V_{DD} range is described in Section 12.0 “Electrical Characteristics” .				
Param No.	Sym.	Characteristic	Min.	Typ	Max.	Units	Conditions
1A	Fosc	External CLKIN Frequency ⁽¹⁾	DC	—	4	MHz	XT Oscillator mode
			DC	—	200	kHz	LP Oscillator mode
		Oscillator Frequency ⁽¹⁾	DC	—	4	MHz	EXTRC Oscillator mode
			DC	—	200	kHz	LP Oscillator mode
1	Tosc	External CLKIN Period ⁽¹⁾	250	—	—	ns	XT Oscillator mode
			5	—	—	μs	LP Oscillator mode
		Oscillator Period ⁽¹⁾	250	—	—	ns	EXTRC Oscillator mode
			250	—	10,000	ns	XT Oscillator mode
5	—	—	μs	LP Oscillator mode			
2	Tcy	Instruction Cycle Time	200	4/Fosc	DC	ns	
3	TosL, TosH	Clock in (OSC1) Low or High Time	50*	—	—	ns	XT Oscillator
			2*	—	—	μs	LP Oscillator
4	TosR, TosF	Clock in (OSC1) Rise or Fall Time	—	—	25*	ns	XT Oscillator
			—	—	50*	ns	LP Oscillator

* These parameters are characterized but not tested.

Note 1: All specified values are based on characterization data for that particular oscillator type under standard operating conditions with the device executing code. Exceeding these specified limits may result in an unstable oscillator operation and/or higher than expected current consumption. When an external clock input is used, the “max” cycle time limit is “DC” (no clock) for all devices.

TABLE 12-6: CALIBRATED INTERNAL RC FREQUENCIES

AC CHARACTERISTICS			Standard Operating Conditions (unless otherwise specified) Operating Temperature $-40^{\circ}\text{C} \leq T_A \leq +85^{\circ}\text{C}$ (industrial), Operating Voltage V_{DD} range is described in Section 12.0 “Electrical Characteristics” .					
Param No.	Sym.	Characteristic	Freq. Tolerance	Min.	Typ†	Max.	Units	Conditions
F10	Fosc	Internal Calibrated INTOSC Frequency ⁽¹⁾	±1%	7.92	8.00	8.08	MHz	3.5V, 25°C
			±2%	7.84	8.00	8.16	MHz	2.5V ≤ V _{DD} ≤ 3.7V 0°C ≤ T _A ≤ +85°C
			±5%	7.60	8.00	8.40	MHz	2.0V ≤ V _{DD} ≤ 3.7V -40°C ≤ T _A ≤ +85°C (Ind.)

* These parameters are characterized but not tested.

† Data in the Typical (“Typ”) column is at 3.7V, 25°C unless otherwise stated. These parameters are for design guidance only and are not tested.

Note 1: To ensure these oscillator frequency tolerances, V_{DD} and V_{SS} must be capacitively decoupled as close to the device as possible. 0.1 μF and 0.01 μF values in parallel are recommended.

FIGURE 12-5: I/O TIMING

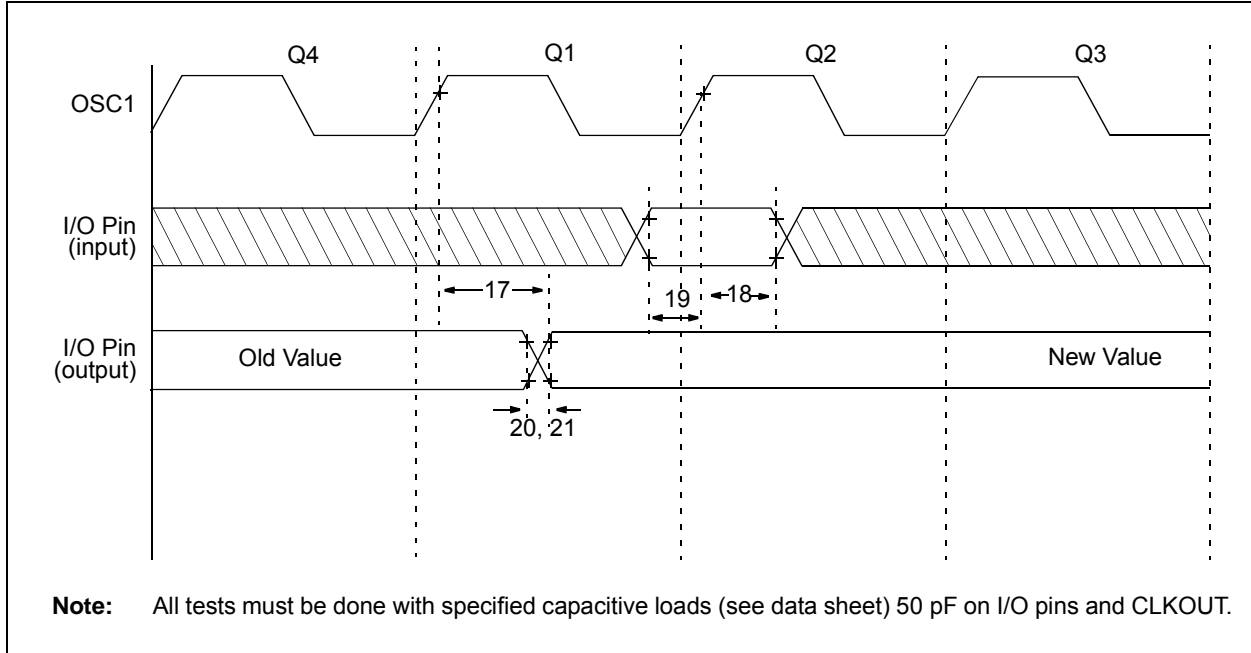

TABLE 12-7: TIMING REQUIREMENTS

AC CHARACTERISTICS		Standard Operating Conditions (unless otherwise specified) Operating Temperature $-40^{\circ}\text{C} \leq T_A \leq +85^{\circ}\text{C}$ (industrial) Operating Voltage V_{DD} range is described in Section 12.0 "Electrical Characteristics" .				
Param No.	Sym.	Characteristic	Min.	Typ ⁽¹⁾	Max.	Units
17	ToSH2iOV	OSC1 \uparrow (Q1 cycle) to Port Out Valid ^{(2), (3)}	—	—	100*	ns
18	ToSH2iOI	OSC1 \uparrow (Q2 cycle) to Port Input Invalid (I/O in hold time) ⁽²⁾	50	—	—	ns
19	TiOV2oS	Port Input Valid to OSC1 \uparrow (I/O in setup time)	20	—	—	ns
20	TiOR	Port Output Rise Time ⁽³⁾	—	10	50**	ns
21	TiOF	Port Output Fall Time ⁽³⁾	—	10	50**	ns

TBD = To be determined.

* These parameters are characterized but not tested.

** These parameters are design targets and are not tested.

Note 1: Data in the Typical ("Typ") column is at 3.7V, 25°C unless otherwise stated. These parameters are for design guidance only and are not tested.

2: Measurements are taken in EXTRC mode.

3: See [Figure 12-3](#) for loading conditions.

PIC12F529T39A

FIGURE 12-6: RESET, WATCHDOG TIMER AND DEVICE RESET TIMER TIMING

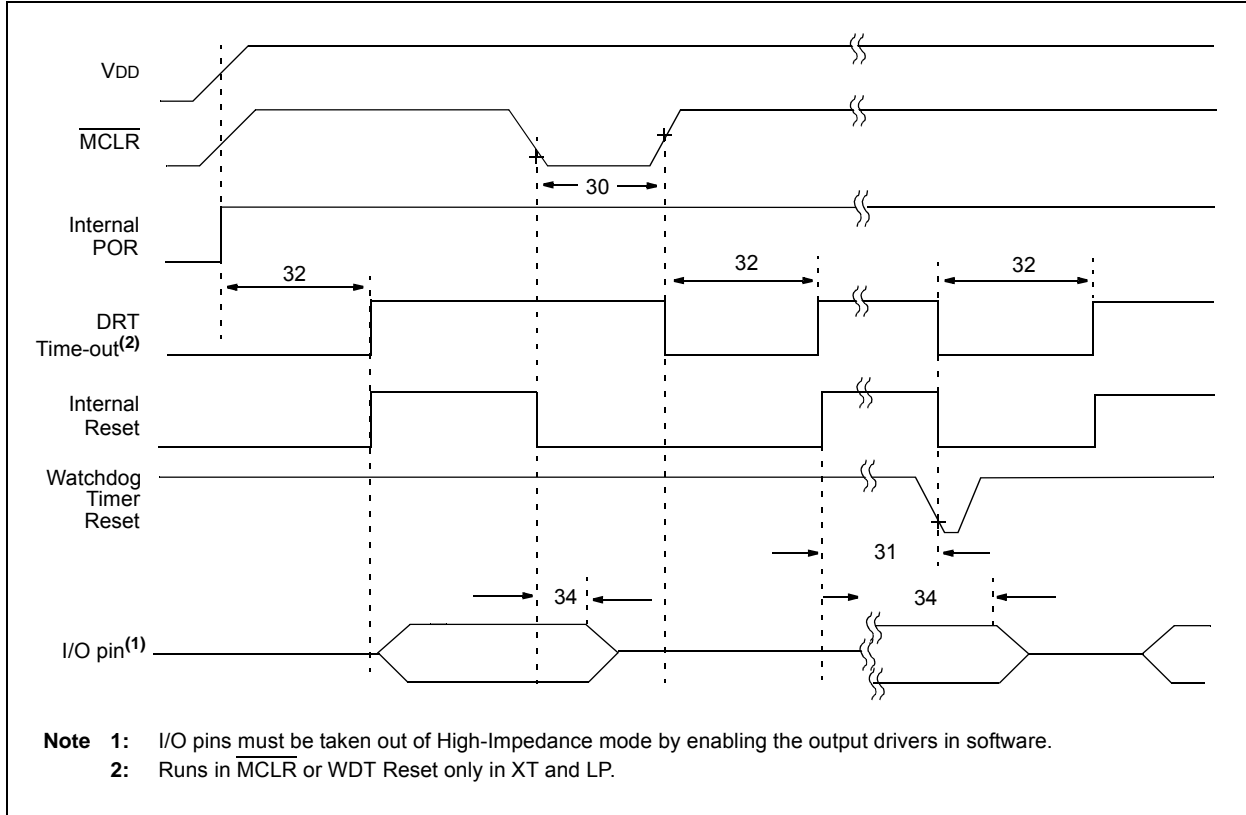

TABLE 12-8: RESET, WATCHDOG TIMER AND DEVICE RESET TIMER – PIC12F529T39A

AC CHARACTERISTICS			Standard Operating Conditions (unless otherwise specified) Operating Temperature $-40^{\circ}\text{C} \leq T_A \leq +85^{\circ}\text{C}$ (industrial) Operating Voltage V_{DD} range is described in Table 12-3 .				
Param No.	Sym.	Characteristic	Min.	Typ ⁽¹⁾	Max.	Units	Conditions
30	TMCL	MCLR Pulse Width (low)	2000*	—	—	ns	$V_{DD} = 3.0\text{V}$
31	TWDT	Watchdog Timer Time-out Period (no prescaler)	9*	20*	35*	ms	$V_{DD} = 3.0\text{V}$ (Industrial)
32	TDRT	Device Reset Timer Period					
		Standard	9*	20*	35*	ms	$V_{DD} = 3.0\text{V}$ (Industrial)
		Short	0.5*	1.125*	2*	ms	$V_{DD} = 3.0\text{V}$ (Industrial)
34	TIOZ	I/O High-impedance from MCLR low	—	—	2000*	ns	

* These parameters are characterized but not tested.

Note 1: Data in the Typical ("Typ") column is at 3.7V, 25°C unless otherwise stated. These parameters are for design guidance only and are not tested.

TABLE 12-9: DRT (DEVICE RESET TIMER PERIOD)

Oscillator Configuration	POR Reset	Subsequent Resets
IntRC and ExtRC	1 ms (typical)	10 μs (typical)
XT and LP	18 ms (typical)	18 ms (typical)

FIGURE 12-7: TIMER0 CLOCK TIMINGS

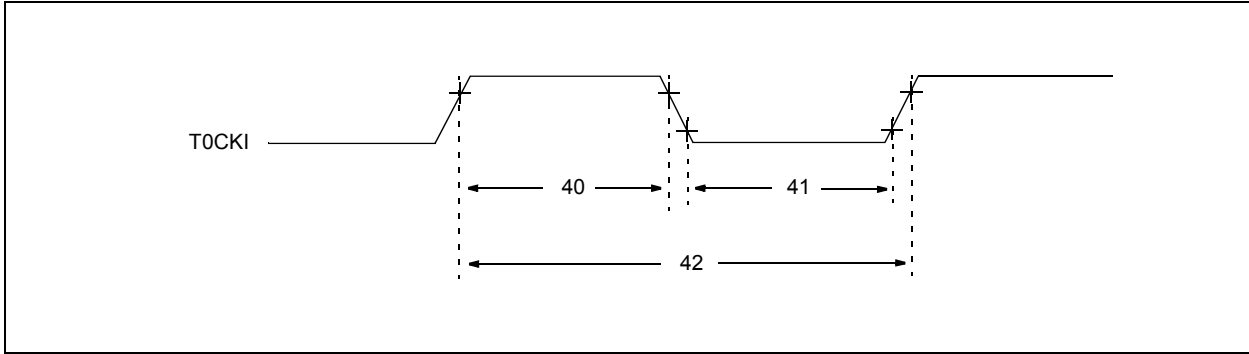

TABLE 12-10: TIMER0 CLOCK REQUIREMENTS

AC CHARACTERISTICS		Standard Operating Conditions (unless otherwise specified) Operating Temperature $-40^{\circ}\text{C} \leq T_A \leq +85^{\circ}\text{C}$ (industrial) Operating Voltage V_{DD} range is described in Table 12-3 .					
Param No.	Sym.	Characteristic	Min.	Typ ⁽¹⁾	Max.	Units	Conditions
40	Tt0H	T0CKI High Pulse Width	No Prescaler	$0.5 T_{CY} + 20^*$	—	—	ns
			With Prescaler	10^*	—	—	ns
41	Tt0L	T0CKI Low Pulse Width	No Prescaler	$0.5 T_{CY} + 20^*$	—	—	ns
			With Prescaler	10^*	—	—	ns
42	Tt0P	T0CKI Period	20 or $T_{CY} + 40^* N$	—	—	ns	Whichever is greater. N = Prescale Value (1, 2, 4, ..., 256)

* These parameters are characterized but not tested.

Note 1: Data in the Typical (“Typ”) column is at 3.7V, 25°C unless otherwise stated. These parameters are for design guidance only and are not tested.

TABLE 12-11: FLASH DATA MEMORY WRITE/ERASE REQUIREMENTS

AC CHARACTERISTICS		Standard Operating Conditions (unless otherwise specified) Operating Temperature $-40^{\circ}\text{C} \leq T_A \leq +85^{\circ}\text{C}$ (industrial) Operating Voltage V_{DD} range is described in Table 12-2 .					
Param No.	Sym.	Characteristic	Min.	Typ ⁽¹⁾	Max.	Units	Conditions
43	T _{DW}	Flash Data Memory Write Cycle Time	2	3.5	5	ms	
44	T _{DE}	Flash Data Memory Erase Cycle Time	2	3	4	ms	

* These parameters are characterized but not tested.

Note 1: Data in the Typical (“Typ”) column is at 3.7V, 25°C unless otherwise stated. These parameters are for design guidance only and are not tested.

PIC12F529T39A

13.0 DC AND AC CHARACTERISTICS GRAPHS AND CHARTS

The graphs and tables provided in this section are for **design guidance** and are **not tested**.

In some graphs or tables, the data presented are **outside specified operating range** (i.e., outside specified V_{DD} range). This is for **information only** and devices are ensured to operate properly only within the specified range.

Note: The graphs and tables provided following this note are a statistical summary based on a limited number of samples and are provided for informational purposes only. The performance characteristics listed herein are not tested or guaranteed. In some graphs or tables, the data presented may be outside the specified operating range (e.g., outside specified power supply range) and therefore, outside the warranted range.

“Typical” represents the mean of the distribution at 25°C. “Maximum” or “minimum” represents (mean + 3 σ) or (mean - 3 σ) respectively, where σ is a standard deviation, over each temperature range.

FIGURE 13-1: TYPICAL I_{DD} vs. Fosc OVER V_{DD} (XT, EXTRC mode)

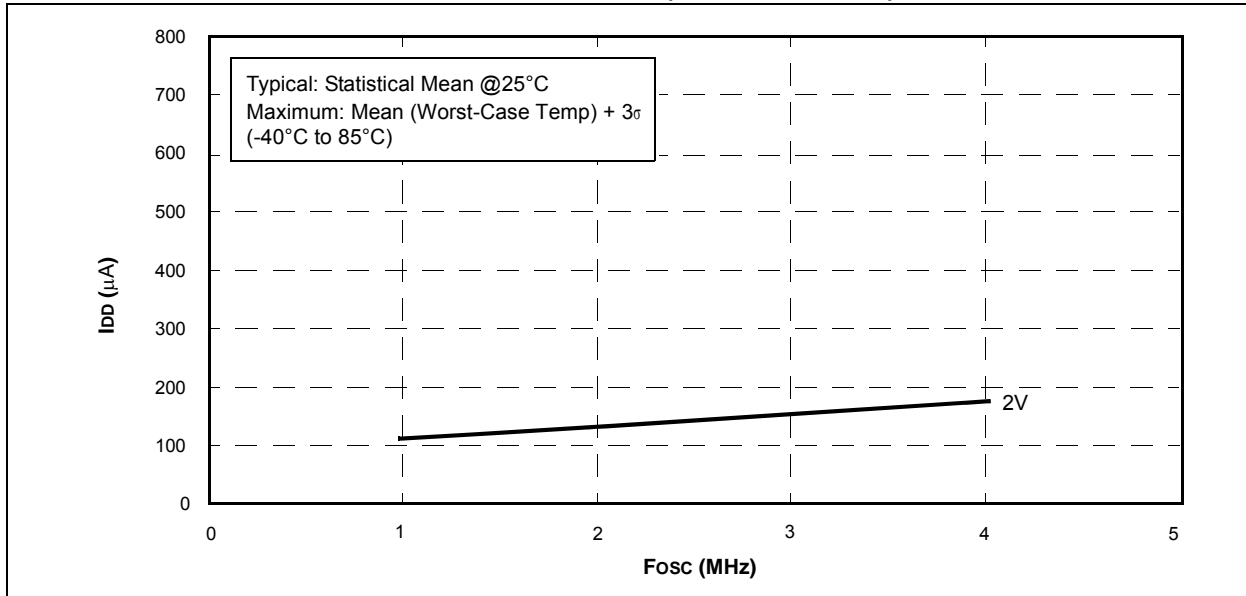

FIGURE 13-2: MAXIMUM I_{DD} vs. Fosc OVER V_{DD} (XT, EXTRC mode)

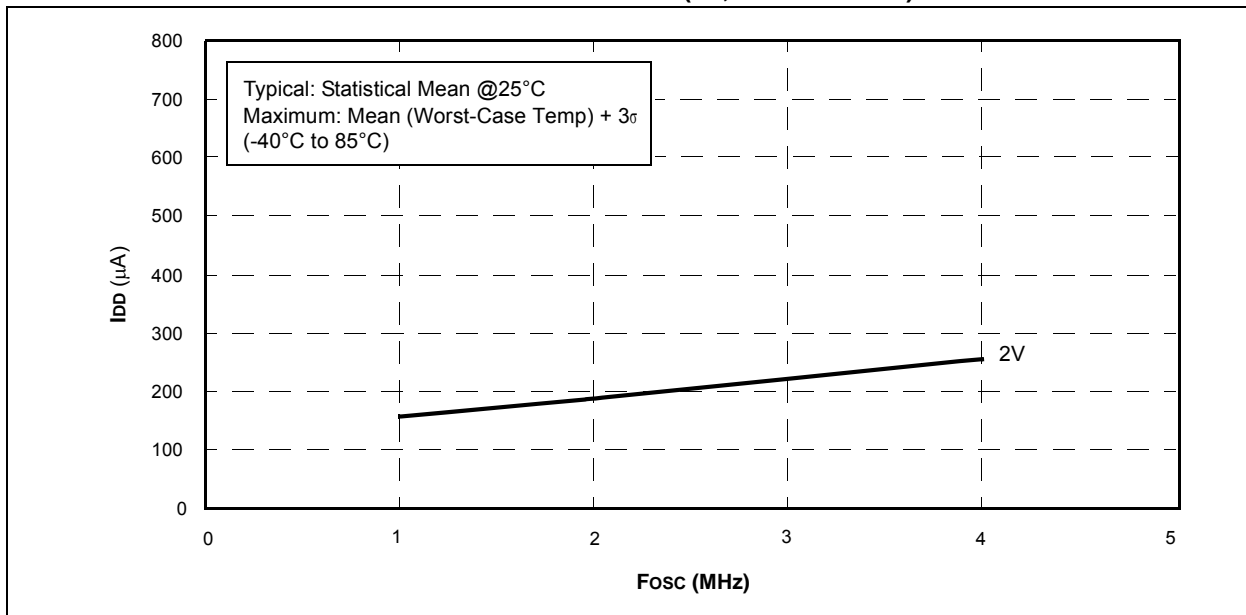
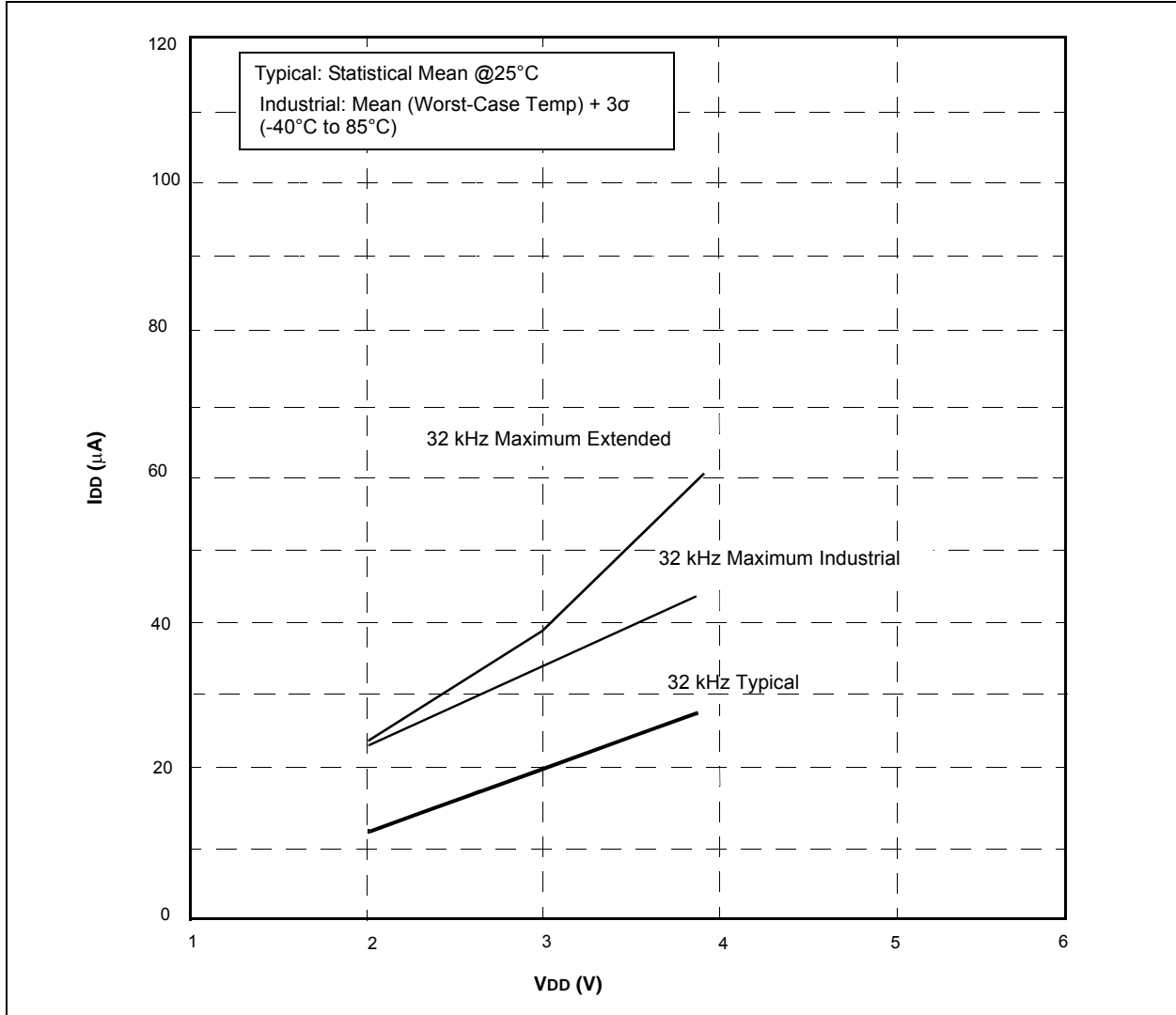

FIGURE 13-3: I_{DD} vs. V_{DD} OVER F_{osc} (LP MODE)



PIC12F529T39A

FIGURE 13-4: TYPICAL IPD vs. VDD (SLEEP MODE, ALL PERIPHERALS DISABLED)

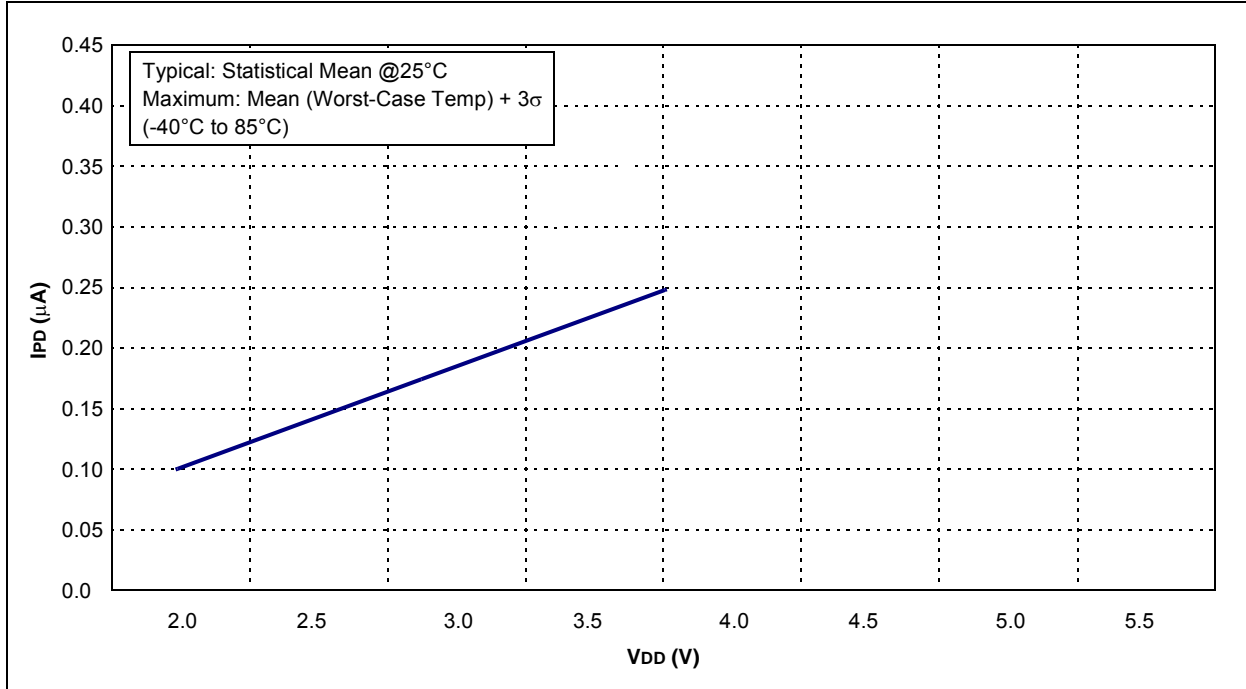

FIGURE 13-5: MAXIMUM IPD vs. VDD (SLEEP MODE, ALL PERIPHERALS DISABLED)

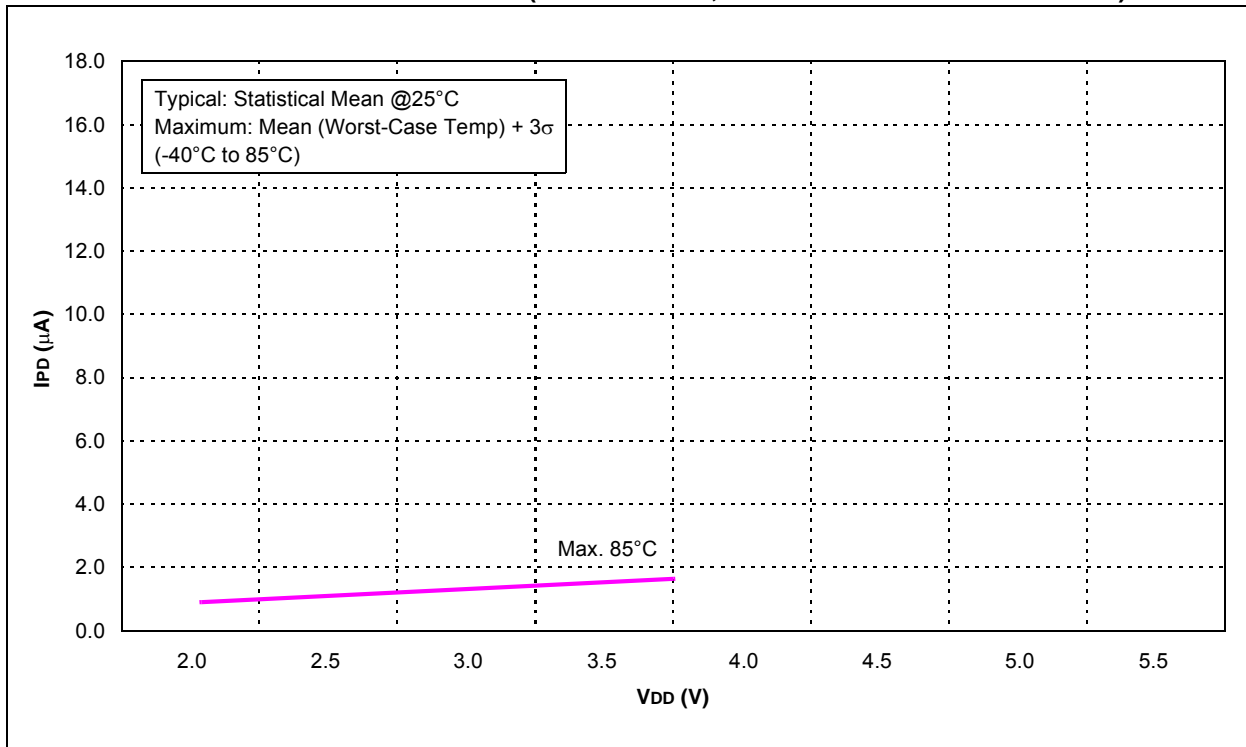

FIGURE 13-6: TYPICAL WDT IPD vs. VDD

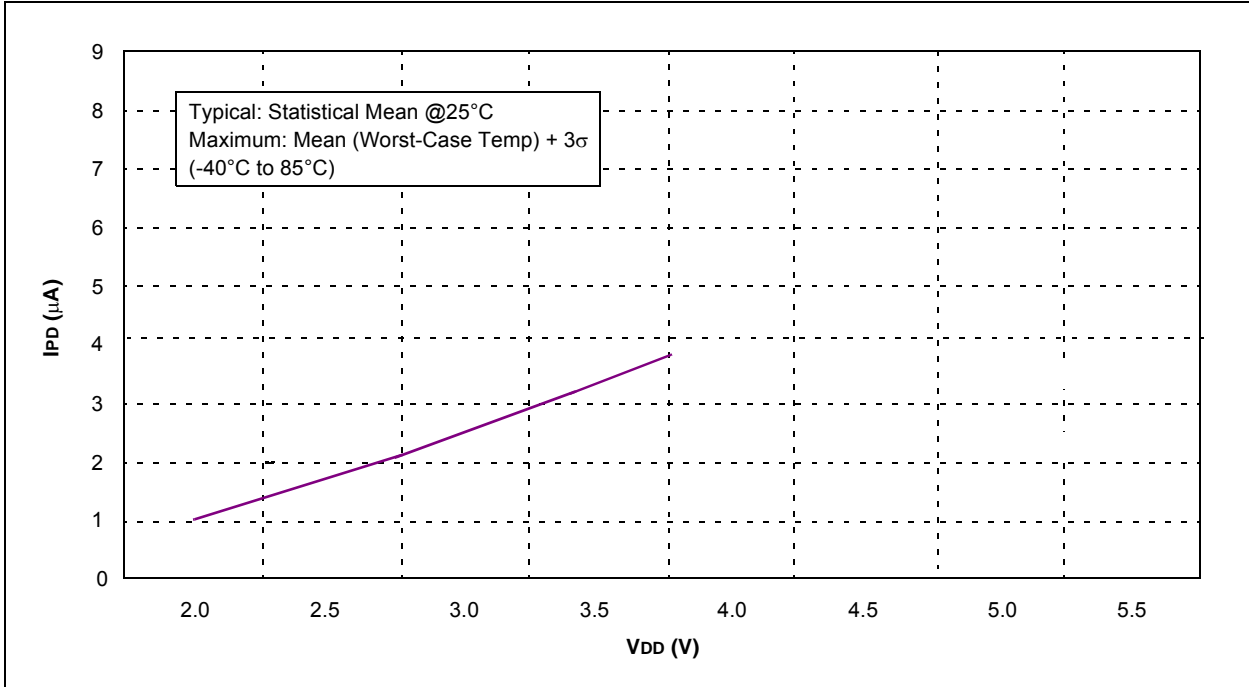
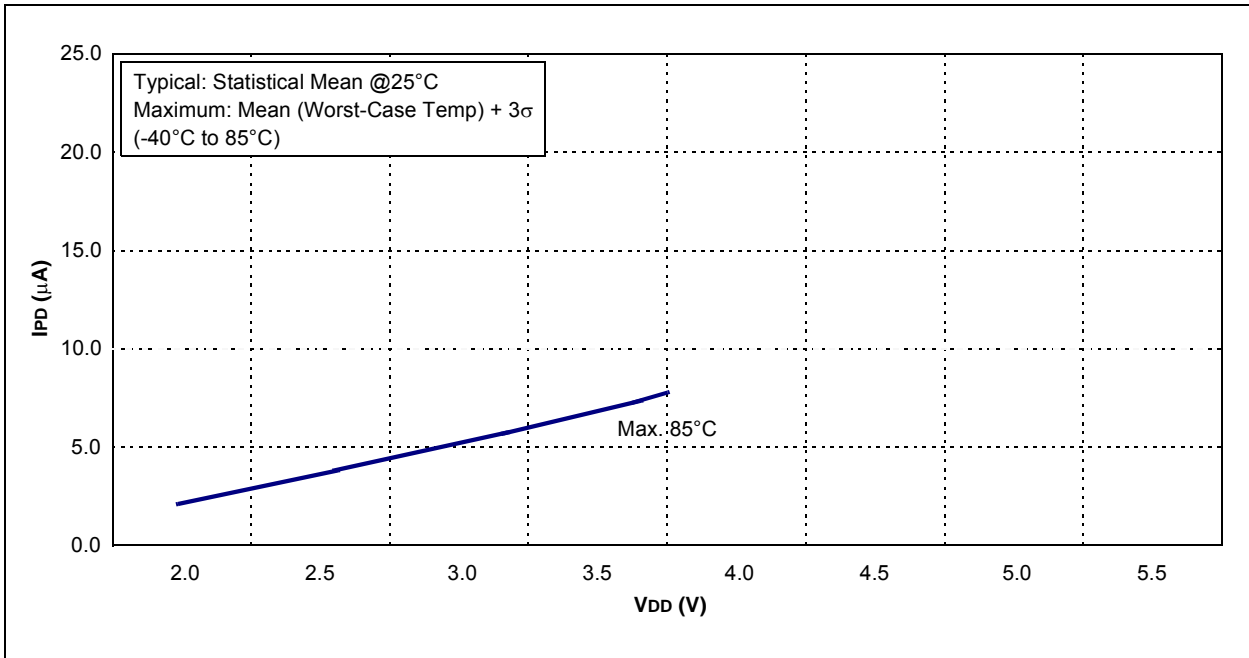

FIGURE 13-7: MAXIMUM WDT IPD vs. VDD OVER TEMPERATURE



PIC12F529T39A

FIGURE 13-8: WDT TIME-OUT vs. V_{DD} OVER TEMPERATURE (NO PRESCALER)

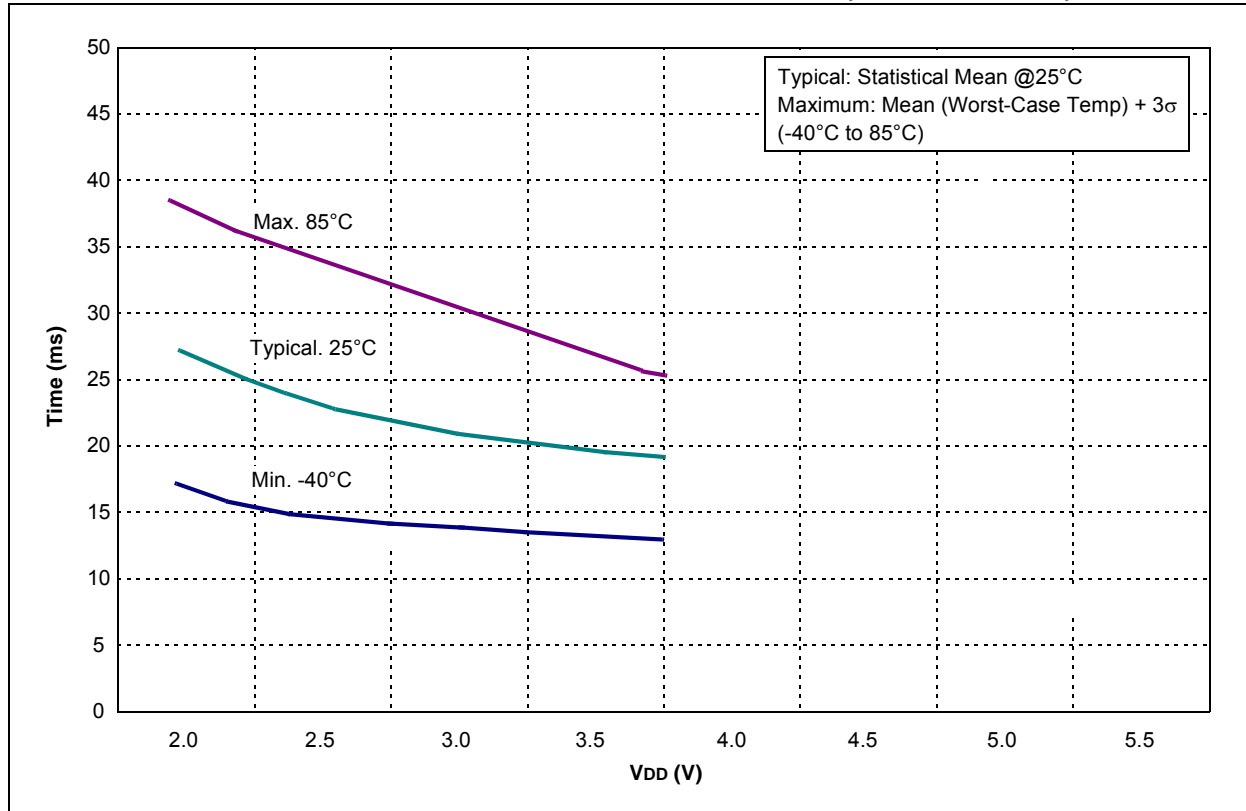

FIGURE 13-9: VOL vs. IOL OVER TEMPERATURE (VDD = 3.0V)

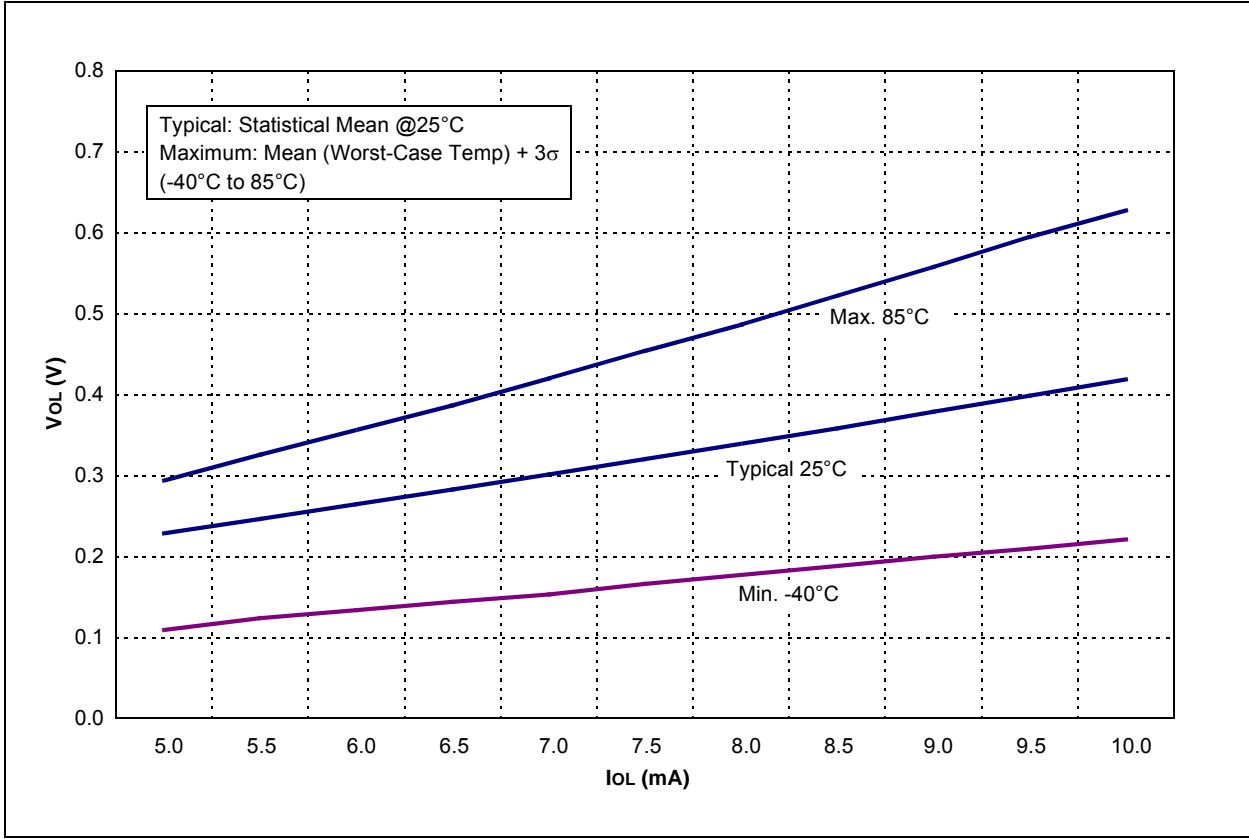
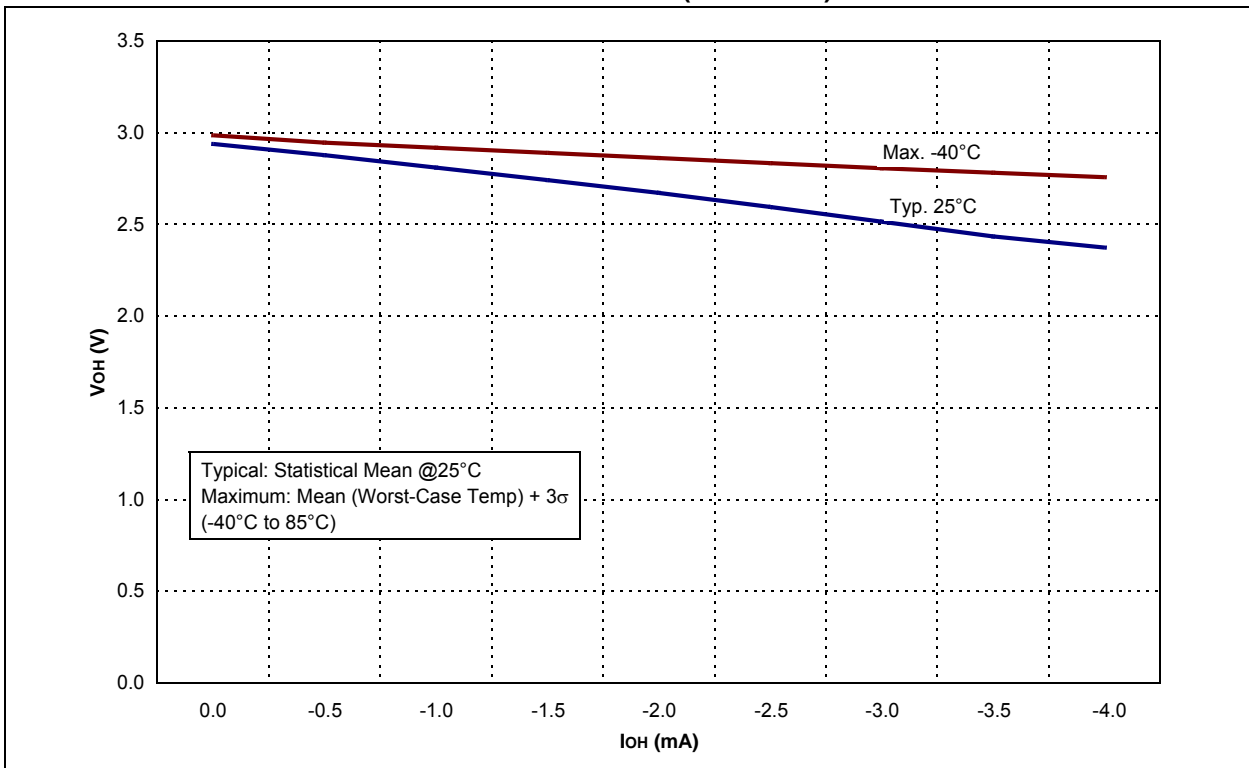

FIGURE 13-10: VOH vs. IOH OVER TEMPERATURE (VDD = 3.0V)



PIC12F529T39A

FIGURE 13-11: TTL INPUT THRESHOLD V_{IN} vs. V_{DD}

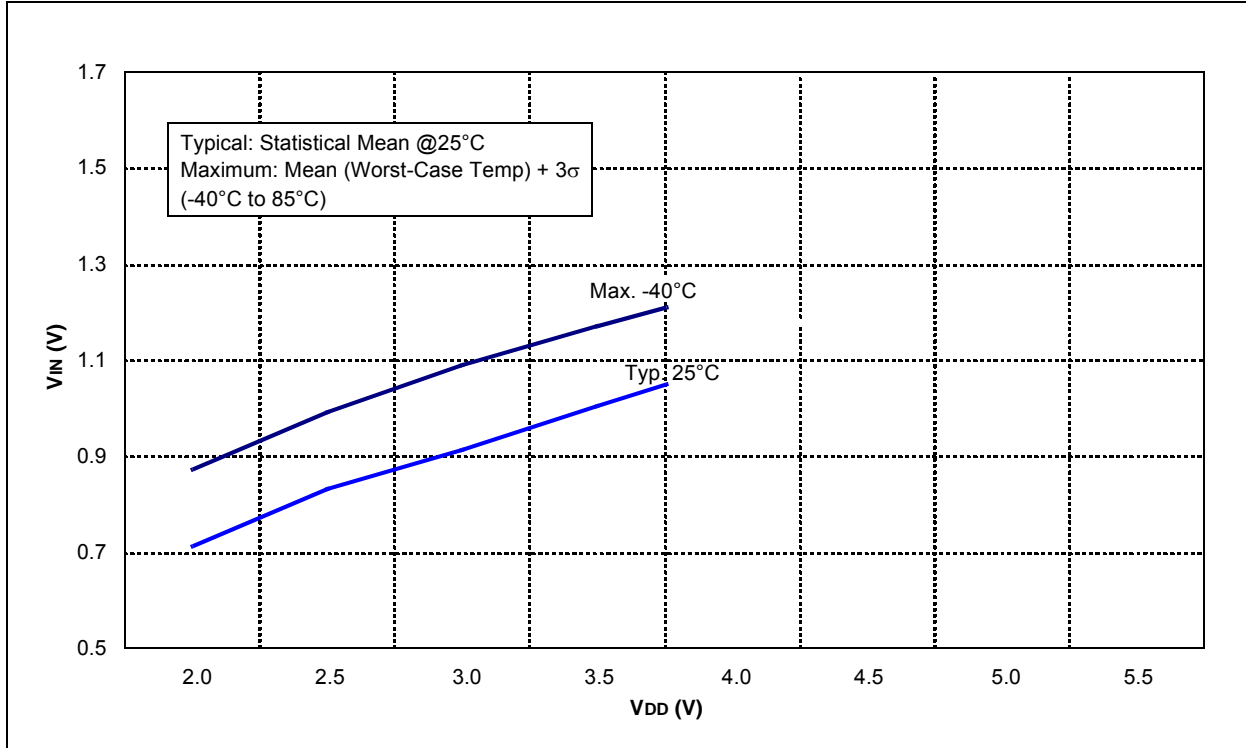

FIGURE 13-12: SCHMITT TRIGGER INPUT THRESHOLD V_{IN} vs. V_{DD}

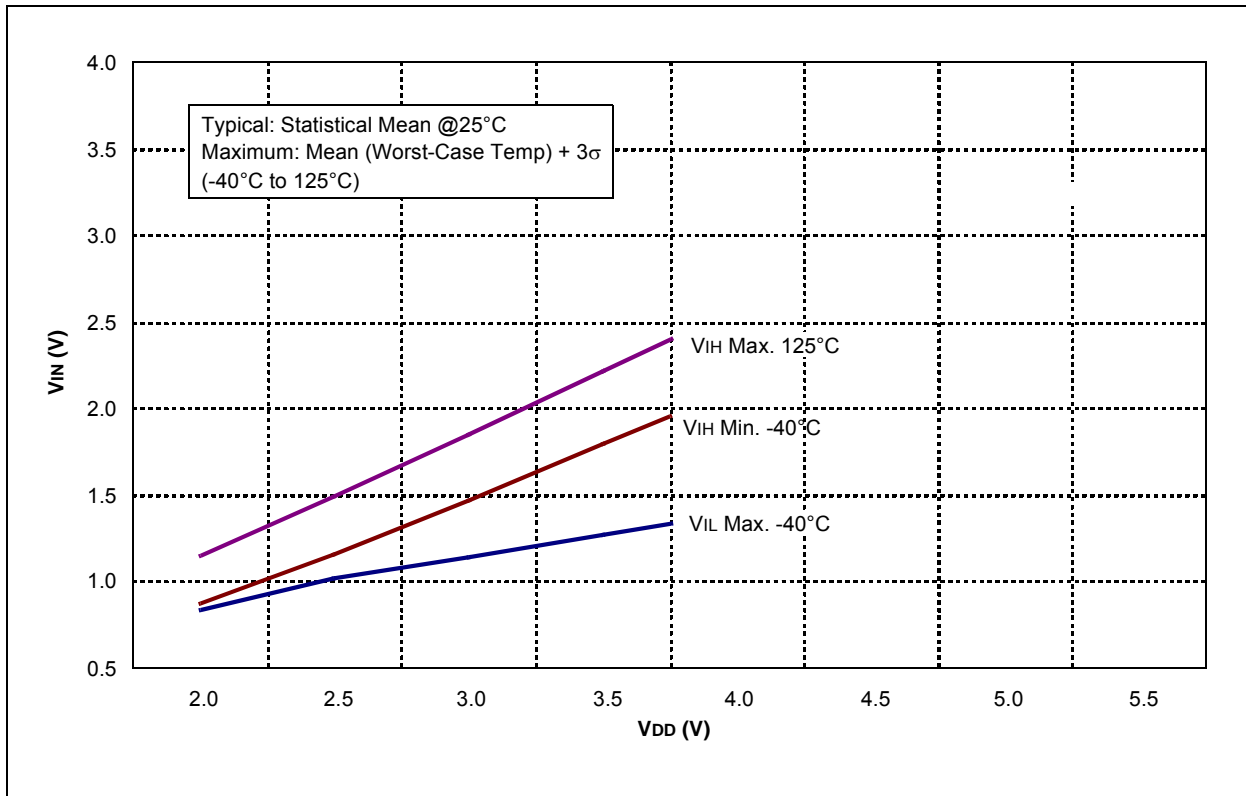
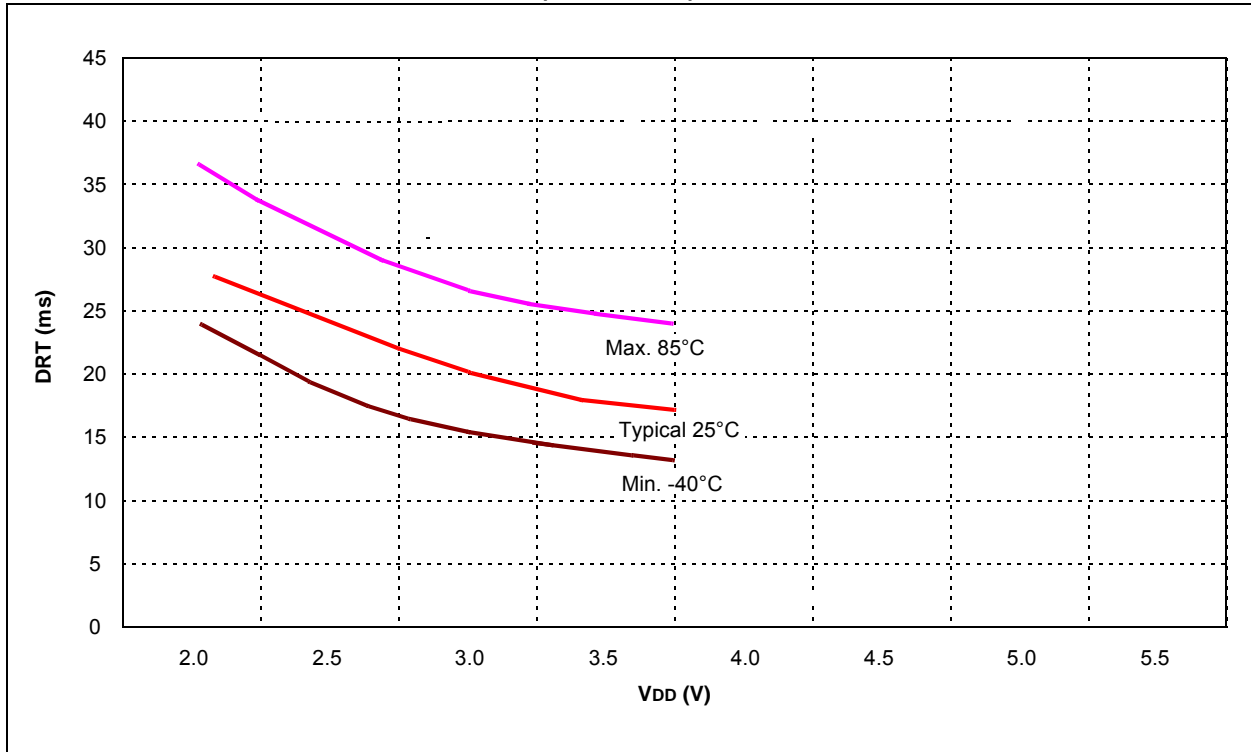

FIGURE 13-13: DEVICE RESET TIMER (XT AND LP) vs. VDD



PIC12F529T39A

14.0 PACKAGING INFORMATION

14.1 Package Marking Information

14-Lead TSSOP (4.4 mm)

Example

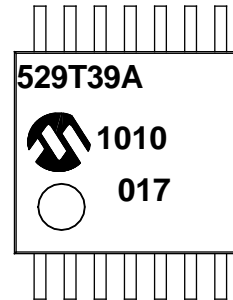
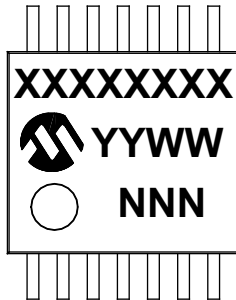

Legend:	XX...X	Customer-specific information
	Y	Year code (last digit of calendar year)
	YY	Year code (last 2 digits of calendar year)
	WW	Week code (week of January 1 is week '01')
	NNN	Alphanumeric traceability code
	(e3)	Pb-free JEDEC designator for Matte Tin (Sn)
	*	This package is Pb-free. The Pb-free JEDEC designator (e3) can be found on the outer packaging for this package.
Note:	In the event the full Microchip part number cannot be marked on one line, it will be carried over to the next line, thus limiting the number of available characters for customer-specific information.	

14.2 Package Details

The following sections give the technical details of the packages.

14-Lead Plastic Thin Shrink Small Outline (ST) - 4.4 mm Body [TSSOP]

Note: For the most current package drawings, please see the Microchip Packaging Specification located at <http://www.microchip.com/packaging>

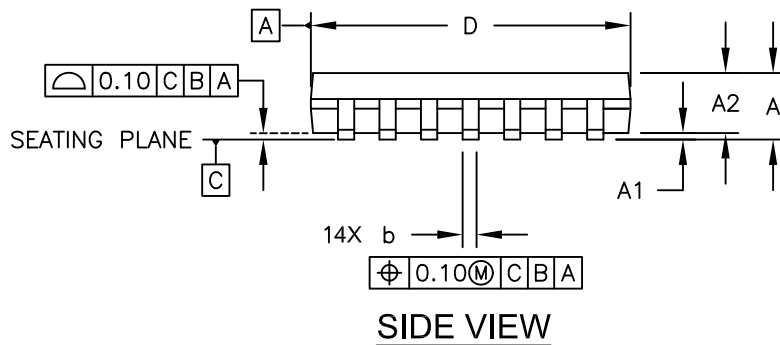
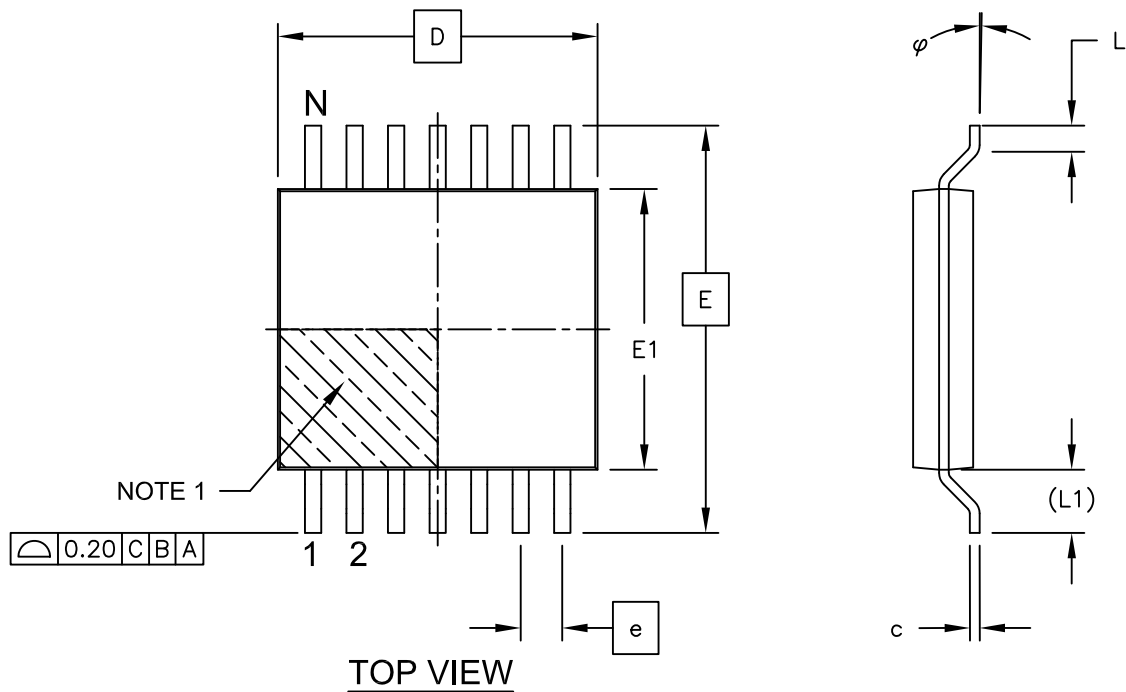

Microchip Technology Drawing C04-087C Sheet 1 of 2

PIC12F529T39A

14-Lead Plastic Thin Shrink Small Outline (ST) - 4.4 mm Body [TSSOP]

Note: For the most current package drawings, please see the Microchip Packaging Specification located at <http://www.microchip.com/packaging>

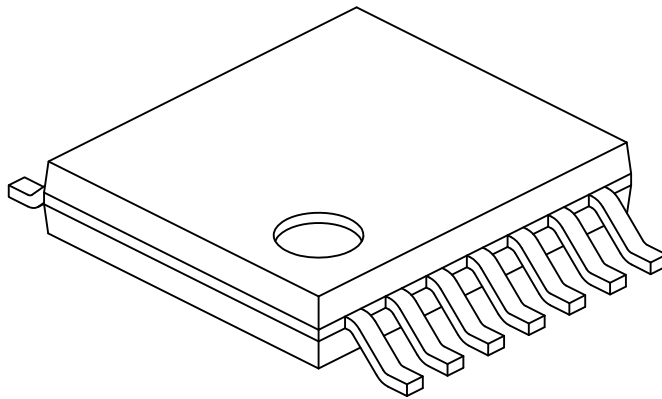

Dimension Limits	Units	MILLIMETERS		
		MIN	NOM	MAX
Number of Pins	N	14		
Pitch	e	0.65 BSC		
Overall Height	A	-	-	1.20
Molded Package Thickness	A2	0.80	1.00	1.05
Standoff	A1	0.05	-	0.15
Overall Width	E	6.40 BSC		
Molded Package Width	E1	4.30	4.40	4.50
Molded Package Length	D	4.90	5.00	5.10
Foot Length	L	0.45	0.60	0.75
Footprint	(L1)	1.00 REF		
Foot Angle	φ	0°	-	8°
Lead Thickness	c	0.09	-	0.20
Lead Width	b	0.19	-	0.30

Notes:

1. Pin 1 visual index feature may vary, but must be located within the hatched area.
2. Dimensions D and E1 do not include mold flash or protrusions. Mold flash or protrusions shall not exceed 0.15mm per side.
3. Dimensioning and tolerancing per ASME Y14.5M

BSC: Basic Dimension. Theoretically exact value shown without tolerances.

REF: Reference Dimension, usually without tolerance, for information purposes only.

Microchip Technology Drawing No. C04-087C Sheet 2 of 2

14-Lead Plastic Thin Shrink Small Outline (ST) - 4.4 mm Body [TSSOP]

Note: For the most current package drawings, please see the Microchip Packaging Specification located at <http://www.microchip.com/packaging>

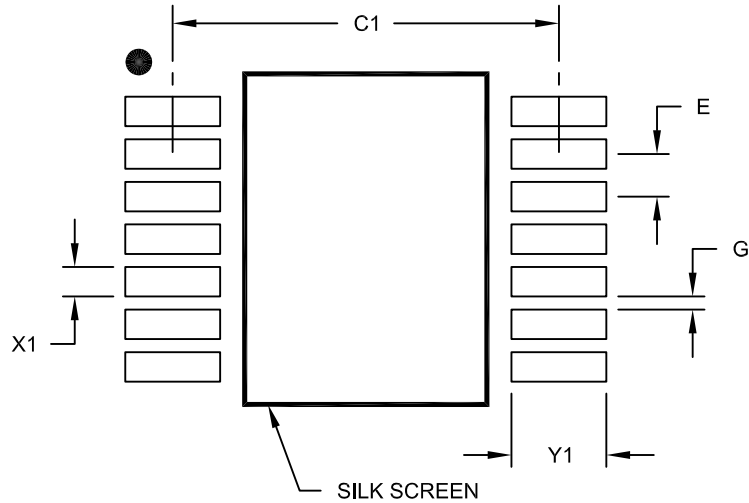

RECOMMENDED LAND PATTERN

		Units	MILLIMETERS		
Dimension Limits			MIN	NOM	MAX
Contact Pitch	E		0.65 BSC		
Contact Pad Spacing	C1			5.90	
Contact Pad Width (X14)	X1				0.45
Contact Pad Length (X14)	Y1				1.45
Distance Between Pads	G	0.20			

Notes:

1. Dimensioning and tolerancing per ASME Y14.5M

BSC: Basic Dimension. Theoretically exact value shown without tolerances.

Microchip Technology Drawing No. C04-2087A

PIC12F529T39A

APPENDIX A: DATA SHEET REVISION HISTORY

Revision A (05/2012)

Initial release.

Revision B (01/2015)

Updated Register 8-1 and Table 9-3; Other minor corrections.

THE MICROCHIP WEB SITE

Microchip provides online support via our WWW site at www.microchip.com. This web site is used as a means to make files and information easily available to customers. Accessible by using your favorite Internet browser, the web site contains the following information:

- **Product Support** – Data sheets and errata, application notes and sample programs, design resources, user's guides and hardware support documents, latest software releases and archived software
- **General Technical Support** – Frequently Asked Questions (FAQ), technical support requests, online discussion groups, Microchip consultant program member listing
- **Business of Microchip** – Product selector and ordering guides, latest Microchip press releases, listing of seminars and events, listings of Microchip sales offices, distributors and factory representatives

CUSTOMER CHANGE NOTIFICATION SERVICE

Microchip's customer notification service helps keep customers current on Microchip products. Subscribers will receive e-mail notification whenever there are changes, updates, revisions or errata related to a specified product family or development tool of interest.

To register, access the Microchip web site at www.microchip.com. Under "Support", click on "Customer Change Notification" and follow the registration instructions.

CUSTOMER SUPPORT

Users of Microchip products can receive assistance through several channels:

- Distributor or Representative
- Local Sales Office
- Field Application Engineer (FAE)
- Technical Support

Customers should contact their distributor, representative or Field Application Engineer (FAE) for support. Local sales offices are also available to help customers. A listing of sales offices and locations is included in the back of this document.

Technical support is available through the web site at: <http://microchip.com/support>

PIC12F529T39A

PRODUCT IDENTIFICATION SYSTEM

To order or obtain information, e.g., on pricing or delivery, refer to the factory or the listed sales office.

<u>PART NO.</u>	<u>[X]⁽¹⁾</u>	-	<u>X</u>	<u>/XX</u>	<u>XXX</u>
Device	Tape and Reel Option		Temperature Range	Package	Pattern
Device:	PIC12F529T39A				
Tape and Reel Option:	Blank = Standard packaging (tube or tray) T = Tape and Reel ⁽¹⁾				
Temperature Range:	I = -40°C to +85°C (Industrial)				
Package:	ST = TSSOP				
Pattern:	QTP, SQTP, Code or Special Requirements (blank otherwise)				

Examples:

a) PIC12F529T39AT - I/ST 301
Tape and Reel,
Industrial temperature,
TSSOP package
QTP pattern #301

Note 1: Tape and Reel identifier only appears in the catalog part number description. This identifier is used for ordering purposes and is not printed on the device package. Check with your Microchip Sales Office for package availability with the Tape and Reel option.

Note the following details of the code protection feature on Microchip devices:

- Microchip products meet the specification contained in their particular Microchip Data Sheet.
- Microchip believes that its family of products is one of the most secure families of its kind on the market today, when used in the intended manner and under normal conditions.
- There are dishonest and possibly illegal methods used to breach the code protection feature. All of these methods, to our knowledge, require using the Microchip products in a manner outside the operating specifications contained in Microchip's Data Sheets. Most likely, the person doing so is engaged in theft of intellectual property.
- Microchip is willing to work with the customer who is concerned about the integrity of their code.
- Neither Microchip nor any other semiconductor manufacturer can guarantee the security of their code. Code protection does not mean that we are guaranteeing the product as “unbreakable.”

Code protection is constantly evolving. We at Microchip are committed to continuously improving the code protection features of our products. Attempts to break Microchip's code protection feature may be a violation of the Digital Millennium Copyright Act. If such acts allow unauthorized access to your software or other copyrighted work, you may have a right to sue for relief under that Act.

Information contained in this publication regarding device applications and the like is provided only for your convenience and may be superseded by updates. It is your responsibility to ensure that your application meets with your specifications. MICROCHIP MAKES NO REPRESENTATIONS OR WARRANTIES OF ANY KIND WHETHER EXPRESS OR IMPLIED, WRITTEN OR ORAL, STATUTORY OR OTHERWISE, RELATED TO THE INFORMATION, INCLUDING BUT NOT LIMITED TO ITS CONDITION, QUALITY, PERFORMANCE, MERCHANTABILITY OR FITNESS FOR PURPOSE. Microchip disclaims all liability arising from this information and its use. Use of Microchip devices in life support and/or safety applications is entirely at the buyer's risk, and the buyer agrees to defend, indemnify and hold harmless Microchip from any and all damages, claims, suits, or expenses resulting from such use. No licenses are conveyed, implicitly or otherwise, under any Microchip intellectual property rights.

Trademarks

The Microchip name and logo, the Microchip logo, dsPIC, FlashFlex, flexPWR, JukeBlox, KEELOQ, KEELOQ logo, Klear, LANCheck, MediaLB, MOST, MOST logo, MPLAB, OptoLyzer, PIC, PICSTART, PIC³² logo, RightTouch, SpyNIC, SST, SST Logo, SuperFlash and UNI/O are registered trademarks of Microchip Technology Incorporated in the U.S.A. and other countries.

The Embedded Control Solutions Company and mTouch are registered trademarks of Microchip Technology Incorporated in the U.S.A.

Analog-for-the-Digital Age, BodyCom, chipKIT, chipKIT logo, CodeGuard, dsPICDEM, dsPICDEM.net, ECAN, In-Circuit Serial Programming, ICSP, Inter-Chip Connectivity, KlearNet, KlearNet logo, MiWi, MPASM, MPF, MPLAB Certified logo, MPLIB, MPLINK, MultiTRAK, NetDetach, Omniscient Code Generation, PICDEM, PICDEM.net, PICkit, PICtail, RightTouch logo, REAL ICE, SQI, Serial Quad I/O, Total Endurance, TSHARC, USBCheck, VariSense, ViewSpan, WiperLock, Wireless DNA, and ZENA are trademarks of Microchip Technology Incorporated in the U.S.A. and other countries.

SQTP is a service mark of Microchip Technology Incorporated in the U.S.A.

Silicon Storage Technology is a registered trademark of Microchip Technology Inc. in other countries.

GestIC is a registered trademarks of Microchip Technology Germany II GmbH & Co. KG, a subsidiary of Microchip Technology Inc., in other countries.

All other trademarks mentioned herein are property of their respective companies.

© 2012-2015, Microchip Technology Incorporated, Printed in the U.S.A., All Rights Reserved.

ISBN: 978-1-63276-934-3

QUALITY MANAGEMENT SYSTEM
CERTIFIED BY DNV
== ISO/TS 16949 ==

Microchip received ISO/TS-16949:2009 certification for its worldwide headquarters, design and wafer fabrication facilities in Chandler and Tempe, Arizona; Gresham, Oregon and design centers in California and India. The Company's quality system processes and procedures are for its PIC[®] MCUs and dsPIC[®] DSCs, KEELOQ[®] code hopping devices, Serial EEPROMs, microperipherals, nonvolatile memory and analog products. In addition, Microchip's quality system for the design and manufacture of development systems is ISO 9001:2000 certified.



MICROCHIP

Worldwide Sales and Service

AMERICAS

Corporate Office
2355 West Chandler Blvd.
Chandler, AZ 85224-6199
Tel: 480-792-7200
Fax: 480-792-7277
Technical Support:
<http://www.microchip.com/support>
Web Address:
www.microchip.com

Atlanta
Duluth, GA
Tel: 678-957-9614
Fax: 678-957-1455

Austin, TX
Tel: 512-257-3370

Boston
Westborough, MA
Tel: 774-760-0087
Fax: 774-760-0088

Chicago
Itasca, IL
Tel: 630-285-0071
Fax: 630-285-0075

Cleveland
Independence, OH
Tel: 216-447-0464
Fax: 216-447-0643

Dallas
Addison, TX
Tel: 972-818-7423
Fax: 972-818-2924

Detroit
Novi, MI
Tel: 248-848-4000

Houston, TX
Tel: 281-894-5983

Indianapolis
Noblesville, IN
Tel: 317-773-8323
Fax: 317-773-5453

Los Angeles
Mission Viejo, CA
Tel: 949-462-9523
Fax: 949-462-9608

New York, NY
Tel: 631-435-6000

San Jose, CA
Tel: 408-735-9110

Canada - Toronto
Tel: 905-673-0699
Fax: 905-673-6509

ASIA/PACIFIC

Asia Pacific Office
Suites 3707-14, 37th Floor
Tower 6, The Gateway
Harbour City, Kowloon
Hong Kong
Tel: 852-2943-5100
Fax: 852-2401-3431

Australia - Sydney
Tel: 61-2-9868-6733
Fax: 61-2-9868-6755

China - Beijing
Tel: 86-10-8569-7000
Fax: 86-10-8528-2104

China - Chengdu
Tel: 86-28-8665-5511
Fax: 86-28-8665-7889

China - Chongqing
Tel: 86-23-8980-9588
Fax: 86-23-8980-9500

China - Hangzhou
Tel: 86-571-8792-8115
Fax: 86-571-8792-8116

China - Hong Kong SAR
Tel: 852-2943-5100
Fax: 852-2401-3431

China - Nanjing
Tel: 86-25-8473-2460
Fax: 86-25-8473-2470

China - Qingdao
Tel: 86-532-8502-7355
Fax: 86-532-8502-7205

China - Shanghai
Tel: 86-21-5407-5533
Fax: 86-21-5407-5066

China - Shenyang
Tel: 86-24-2334-2829
Fax: 86-24-2334-2393

China - Shenzhen
Tel: 86-755-8864-2200
Fax: 86-755-8203-1760

China - Wuhan
Tel: 86-27-5980-5300
Fax: 86-27-5980-5118

China - Xian
Tel: 86-29-8833-7252
Fax: 86-29-8833-7256

China - Xiamen
Tel: 86-592-2388138
Fax: 86-592-2388130

China - Zhuhai
Tel: 86-756-3210040
Fax: 86-756-3210049

ASIA/PACIFIC

India - Bangalore
Tel: 91-80-3090-4444
Fax: 91-80-3090-4123

India - New Delhi
Tel: 91-11-4160-8631
Fax: 91-11-4160-8632

India - Pune
Tel: 91-20-3019-1500

Japan - Osaka
Tel: 81-6-6152-7160
Fax: 81-6-6152-9310

Japan - Tokyo
Tel: 81-3-6880-3770
Fax: 81-3-6880-3771

Korea - Daegu
Tel: 82-53-744-4301
Fax: 82-53-744-4302

Korea - Seoul
Tel: 82-2-554-7200
Fax: 82-2-558-5932 or
82-2-558-5934

Malaysia - Kuala Lumpur
Tel: 60-3-6201-9857
Fax: 60-3-6201-9859

Malaysia - Penang
Tel: 60-4-227-8870
Fax: 60-4-227-4068

Philippines - Manila
Tel: 63-2-634-9065
Fax: 63-2-634-9069

Singapore
Tel: 65-6334-8870
Fax: 65-6334-8850

Taiwan - Hsin Chu
Tel: 886-3-5778-366
Fax: 886-3-5770-955

Taiwan - Kaohsiung
Tel: 886-7-213-7830

Taiwan - Taipei
Tel: 886-2-2508-8600
Fax: 886-2-2508-0102

Thailand - Bangkok
Tel: 66-2-694-1351
Fax: 66-2-694-1350

EUROPE

Austria - Wels
Tel: 43-7242-2244-39
Fax: 43-7242-2244-393

Denmark - Copenhagen
Tel: 45-4450-2828
Fax: 45-4485-2829

France - Paris
Tel: 33-1-69-53-63-20
Fax: 33-1-69-30-90-79

Germany - Dusseldorf
Tel: 49-2129-3766400

Germany - Munich
Tel: 49-89-627-144-0
Fax: 49-89-627-144-44

Germany - Pforzheim
Tel: 49-7231-424750

Italy - Milan
Tel: 39-0331-742611
Fax: 39-0331-466781

Italy - Venice
Tel: 39-049-7625286

Netherlands - Drunen
Tel: 31-416-690399
Fax: 31-416-690340

Poland - Warsaw
Tel: 48-22-3325737

Spain - Madrid
Tel: 34-91-708-08-90
Fax: 34-91-708-08-91

Sweden - Stockholm
Tel: 46-8-5090-4654

UK - Wokingham
Tel: 44-118-921-5800
Fax: 44-118-921-5820

03/25/14

Looking for pricing, stock, or lifecycle information?

Click below to explore more details on WIN SOURCE:

- ⊖ [View PIC12F529T39A-I/ST on WIN SOURCE](#)
- ⊖ [Microchip Technology](#) Information

Optimize Your Supply Chain with WIN SOURCE Solutions

- ✓ Global Sourcing Solution
- ✓ Obsolete Management
- ✓ Cost Control Management
- ✓ Shortage Management
- ✓ Alternative Solution
- ✓ Excess Inventory Management