



**THE DATASHEET OF  
TPA2006D1DRBT**



# TPA2006D1 1.45-W MONO Filter-free Class-D Audio Power Amplifier with 1.8-V Compatible Input Thresholds

## 1 Features

- Maximum Battery Life and Minimum Heat
  - Efficiency With an 8-Ω Speaker:
    - 88% at 400 mW
    - 80% at 100 mW
  - 2.8-mA Quiescent Current
  - 0.5-μA Shutdown Current
- SHUTDOWN Pin has 1.8-V Compatible Thresholds
- Capable of Driving an 8-Ω Speaker ( $2.5\text{ V} \leq V_{DD} \leq 5.5\text{ V}$ ) and a 4-Ω Speaker ( $2.5\text{ V} \leq V_{DD} \leq 4.2\text{ V}$ )
- Only Three External Components
  - Optimized PWM Output Stage Eliminates LC Output Filter
  - Internally Generated 250-kHz Switching Frequency Eliminates Capacitor and Resistor
  - Improved PSRR (–75 dB) and Wide Supply Voltage (2.5 V to 5.5 V) Eliminates Need for a Voltage Regulator
  - Fully Differential Design Reduces RF Rectification and Eliminates Bypass Capacitor
  - Improved CMRR Eliminates Two Input Coupling Capacitors
- Space-Saving 3 mm x 3 mm VSON Package (DRB)

## 2 Applications

Ideal for Wireless or Cellular Handsets and PDAs

## 3 Description

The TPA2006D1 device is a 1.45-W high efficiency filter-free class-D audio power amplifier in a 3 mm × 3 mm VSON package that requires only three external components. The SHUTDOWN pin is fully compatible with 1.8-V logic GPIO, such as are used on low-power cellular chipsets.

Features like 88% efficiency, –75-dB PSRR, improved RF-rectification immunity, and small total PCB footprint make the TPA2006D1 device ideal for cellular handsets. A fast start-up time of 1 ms with minimal pop makes the TPA2006D1 device ideal for PDA applications.

In cellular handsets, the earpiece, speaker phone, and melody ringer can each be driven by the TPA2006D1 device. The TPA2006D1 device allows independent gain while summing signals from separate sources, and has a low 36-μV noise floor, A-weighted.

The TPA2006D1 device has short-circuit and thermal protection.

### Device Information<sup>(1)</sup>

PART NUMBER	PACKAGE	BODY SIZE (NOM)
TPA2006D1	VSON (8)	3.00 mm × 3.00 mm

(1) For all available packages, see the orderable addendum at the end of the datasheet.

### Application Circuit

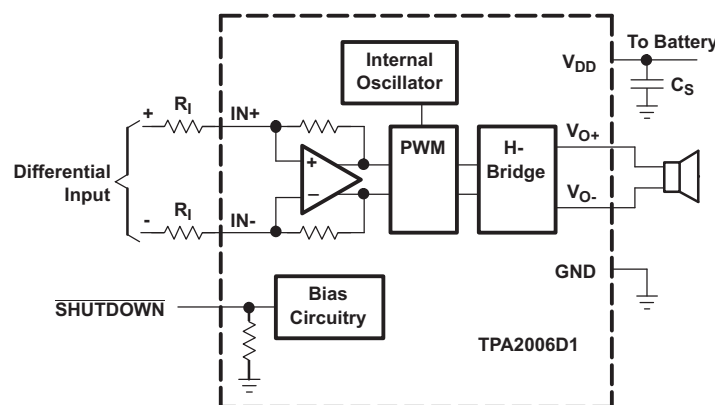

## Table of Contents

<b>1 Features</b> .....	<b>1</b>	9.3 Feature Description .....	<b>11</b>
<b>2 Applications</b> .....	<b>1</b>	9.4 Device Functional Modes .....	<b>15</b>
<b>3 Description</b> .....	<b>1</b>	<b>10 Application and Implementation</b> .....	<b>19</b>
<b>4 Revision History</b> .....	<b>2</b>	10.1 Application Information .....	<b>19</b>
<b>5 Device Comparison Table</b> .....	<b>3</b>	10.2 Typical Application .....	<b>19</b>
<b>6 Pin Configuration and Functions</b> .....	<b>3</b>	10.3 System Examples .....	<b>22</b>
<b>7 Specifications</b> .....	<b>4</b>	<b>11 Power Supply Recommendations</b> .....	<b>22</b>
7.1 Absolute Maximum Ratings .....	<b>4</b>	11.1 Power Supply Decoupling Capacitors .....	<b>22</b>
7.2 ESD Ratings .....	<b>4</b>	<b>12 Layout</b> .....	<b>23</b>
7.3 Recommended Operating Conditions .....	<b>4</b>	12.1 Layout Guidelines .....	<b>23</b>
7.4 Thermal Information .....	<b>4</b>	12.2 Layout Example .....	<b>23</b>
7.5 Electrical Characteristics .....	<b>5</b>	<b>13 Device and Documentation Support</b> .....	<b>24</b>
7.6 Operating Characteristics .....	<b>5</b>	13.1 Community Resources .....	<b>24</b>
7.7 Typical Characteristics .....	<b>6</b>	13.2 Trademarks .....	<b>24</b>
<b>8 Parameter Measurement Information</b> .....	<b>10</b>	13.3 Electrostatic Discharge Caution .....	<b>24</b>
<b>9 Detailed Description</b> .....	<b>11</b>	13.4 Glossary .....	<b>24</b>
9.1 Overview .....	<b>11</b>	<b>14 Mechanical, Packaging, and Orderable Information</b> .....	<b>24</b>
9.2 Functional Block Diagram .....	<b>11</b>		

## 4 Revision History

NOTE: Page numbers for previous revisions may differ from page numbers in the current version.

<b>Changes from Revision A (July 2008) to Revision B</b>	<b>Page</b>
<ul style="list-style-type: none"> <li>Added ESD Rating table, Feature Description section, Device Functional Modes, Application and Implementation section, Power Supply Recommendations section, Layout section, Device and Documentation Support section, and Mechanical, Packaging, and Orderable Information section .....</li> </ul>	<b>1</b>

<b>Changes from Original (September 2006) to Revision A</b>	<b>Page</b>
<ul style="list-style-type: none"> <li>Added Capable of Driving an 8-Ω Speaker and a 4-Ω Speaker .....</li> </ul>	<b>1</b>
<ul style="list-style-type: none"> <li>Added To Description: The TPA2006D1 device has short-circuit and thermal protection. ....</li> </ul>	<b>1</b>
<ul style="list-style-type: none"> <li>Added R<sub>L</sub> Load resistance, to the Abs Max Ratings Table .....</li> </ul>	<b>4</b>
<ul style="list-style-type: none"> <li>Changed Storage Temp - From: –65°C to 85°C To: –65°C to 150°C .....</li> </ul>	<b>4</b>
<ul style="list-style-type: none"> <li>Added graph, <a href="#">Figure 2</a> .....</li> </ul>	<b>6</b>
<ul style="list-style-type: none"> <li>Changed graph, <a href="#">Figure 3</a> .....</li> </ul>	<b>6</b>
<ul style="list-style-type: none"> <li>Changed graph, <a href="#">Figure 7</a> .....</li> </ul>	<b>6</b>
<ul style="list-style-type: none"> <li>Changed graph, <a href="#">Figure 8</a> .....</li> </ul>	<b>6</b>
<ul style="list-style-type: none"> <li>Added graph, <a href="#">Figure 16</a> .....</li> </ul>	<b>7</b>
<ul style="list-style-type: none"> <li>Added graph, <a href="#">Figure 17</a> .....</li> </ul>	<b>8</b>
<ul style="list-style-type: none"> <li>Added graph, <a href="#">Figure 18</a> .....</li> </ul>	<b>8</b>
<ul style="list-style-type: none"> <li>Added and causes pop. Any capacitor in the audio path should have a rating of X7R or better .....</li> </ul>	<b>21</b>

## 5 Device Comparison Table

DEVICE NUMBER	SPEAKER CHANNELS	SPEAKER AMP TYPE	OUTPUT POWER (W)	PSRR (dB)	SUPPLY MIN (V)	SUPPLY MAX (V)	PACKAGE FAMILY
TPA2006D1	Mono	Class D	1.45	75	2.5	5.5	VSON
TPA2005D1	Mono	Class D	1.4	75	2.5	5.5	BGA MICROSTAR JUNIOR
							HVSSOP
							VSON

## 6 Pin Configuration and Functions

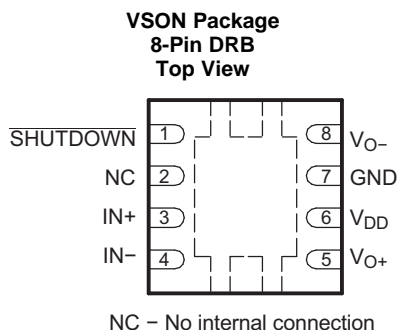

### Pin Functions

PIN		I/O	DESCRIPTION
NAME	NO.		
GND	7	O	High-current ground
IN-	4	I	Negative differential input
IN+	3	I	Positive differential input
NC	2	–	No Connect, not connected internal to the device. May be left unconnected.
SHUTDOWN	1	I	Shutdown pin (active low logic)
V <sub>DD</sub>	6	I	Power supply
V <sub>O+</sub>	5	O	Positive BTL output
V <sub>O-</sub>	8	O	Negative BTL output
Thermal Pad	—	—	Must be soldered to a grounded thermal pad on PCB for best thermal performance.

## 7 Specifications

### 7.1 Absolute Maximum Ratings

 over operating free-air temperature range (unless otherwise noted)<sup>(1)</sup>

		MIN	MAX	UNIT
V <sub>DD</sub>	Supply voltage			
	In active mode	-0.3	6	V
	In $\overline{\text{SHUTDOWN}}$ mode	-0.3	7	V
V <sub>I</sub>	Input voltage	-0.3	V <sub>DD</sub> + 0.3	Ω
R <sub>L</sub>	Load resistance	2.5 ≤ V <sub>DD</sub> ≤ 4.2 V	3.2	Ω
		4.2 < V <sub>DD</sub> ≤ 6 V	6.4	
T <sub>A</sub>	Operating free-air temperature	-40	85	°C
T <sub>J</sub>	Operating junction temperature	-40	150	°C
T <sub>stg</sub>	Storage temperature	-65	150	°C

- (1) Stresses beyond those listed under *Absolute Maximum Ratings* may cause permanent damage to the device. These are stress ratings only, which do not imply functional operation of the device at these or any other conditions beyond those indicated under *Recommended Operating Conditions*. Exposure to absolute-maximum-rated conditions for extended periods may affect device reliability.

### 7.2 ESD Ratings

			VALUE	UNIT
V <sub>(ESD)</sub>	Electrostatic discharge	Human-body model (HBM), per ANSI/ESDA/JEDEC JS-001 <sup>(1)</sup>	±2000	V
		Charged-device model (CDM), per JEDEC specification JESD22-C101 <sup>(2)</sup>	±1500	

- (1) JEDEC document JEP155 states that 500-V HBM allows safe manufacturing with a standard ESD control process.  
 (2) JEDEC document JEP157 states that 250-V CDM allows safe manufacturing with a standard ESD control process.

### 7.3 Recommended Operating Conditions

over operating free-air temperature range (unless otherwise noted)

		MIN	NOM	MAX	UNIT
V <sub>DD</sub>	Supply voltage	2.5		5.5	V
V <sub>IH</sub>	High-level input voltage	$\overline{\text{SHUTDOWN}}$		V <sub>DD</sub>	V
V <sub>IL</sub>	Low-level input voltage	$\overline{\text{SHUTDOWN}}$		0.35	V
R <sub>I</sub>	Input resistor	Gain ≤ 20 V/V (26 dB)	15		kΩ
V <sub>IC</sub>	Common mode input voltage range	V <sub>DD</sub> = 2.5 V, 5.5 V, CMRR ≤ -49 dB	0.5	V <sub>DD</sub> - 0.8	V
T <sub>A</sub>	Operating free-air temperature	-40		85	°C

### 7.4 Thermal Information

THERMAL METRIC <sup>(1)</sup>		TPA2006D1	UNIT
		VSON (DRB)	
		8 PINS	
R <sub>θJA</sub>	Junction-to-ambient thermal resistance	50.9	°C/W
R <sub>θJC(top)</sub>	Junction-to-case (top) thermal resistance	66.2	°C/W
R <sub>θJB</sub>	Junction-to-board thermal resistance	25.9	°C/W
Ψ <sub>JT</sub>	Junction-to-top characterization parameter	1.4	°C/W
Ψ <sub>JB</sub>	Junction-to-board characterization parameter	26	°C/W
R <sub>θJC(bot)</sub>	Junction-to-case (bottom) thermal resistance	7	°C/W

- (1) For more information about traditional and new thermal metrics, see the *Semiconductor and IC Package Thermal Metrics* application report, [SPRA953](#).

## 7.5 Electrical Characteristics

 $T_A = 25^\circ\text{C}$ , over operating free-air temperature range (unless otherwise noted)

PARAMETER		TEST CONDITIONS	MIN	TYP	MAX	UNIT
$ V_{OS} $	Output offset voltage (measured differentially)	$V_I = 0\text{ V}$ , $A_V = 2\text{ V/V}$ , $V_{DD} = 2.5\text{ V to } 5.5\text{ V}$			25	mV
PSRR	Power supply rejection ratio	$V_{DD} = 2.5\text{ V to } 5.5\text{ V}$		-75	-55	dB
CMRR	Common mode rejection ratio	$V_{DD} = 2.5\text{ V to } 5.5\text{ V}$ , $V_{IC} = V_{DD}/2\text{ to } 0.5\text{ V}$ , $V_{IC} = V_{DD}/2\text{ to } V_{DD} - 0.8\text{ V}$		-68	-49	dB
$ I_{IH} $	High-level input current	$V_{DD} = 5.5\text{ V}$ , $V_I = 5.8\text{ V}$			100	$\mu\text{A}$
$ I_{IL} $	Low-level input current	$V_{DD} = 5.5\text{ V}$ , $V_I = -0.3\text{ V}$			5	$\mu\text{A}$
$I_{(Q)}$	Quiescent current	$V_{DD} = 5.5\text{ V}$ , no load		3.4	4.9	mA
		$V_{DD} = 3.6\text{ V}$ , no load		2.8		
		$V_{DD} = 2.5\text{ V}$ , no load		2.2	3.2	
$I_{(SD)}$	Shutdown current	$V_{(SHUTDOWN)} = 0.35\text{ V}$ , $V_{DD} = 2.5\text{ V to } 5.5\text{ V}$		0.5	2	$\mu\text{A}$
$r_{DS(on)}$	Static drain-source on-state resistance	$V_{DD} = 2.5\text{ V}$		770		m $\Omega$
		$V_{DD} = 3.6\text{ V}$		590		
		$V_{DD} = 5.5\text{ V}$		500		
	Output impedance in $\overline{\text{SHUTDOWN}}$	$V_{(SHUTDOWN)} = 0.35\text{ V}$		>1		k $\Omega$
$f_{(sw)}$	Switching frequency	$V_{DD} = 2.5\text{ V to } 5.5\text{ V}$	200	250	300	kHz
	Gain	$V_{DD} = 2.5\text{ V to } 5.5\text{ V}$	$\frac{285\text{ k}\Omega}{R_I}$	$\frac{300\text{ k}\Omega}{R_I}$	$\frac{315\text{ k}\Omega}{R_I}$	$\frac{\text{V}}{\text{V}}$
	Resistance from shutdown to GND			300		k $\Omega$

## 7.6 Operating Characteristics

 $T_A = 25^\circ\text{C}$ , Gain = 2 V/V,  $R_L = 8\ \Omega$  (unless otherwise noted)

PARAMETER		TEST CONDITIONS	MIN	TYP	MAX	UNIT
$P_O$	Output power	THD + N = 10%, $f = 1\text{ kHz}$ , $R_L = 8\ \Omega$	$V_{DD} = 5\text{ V}$		1.45	W
			$V_{DD} = 3.6\text{ V}$		0.73	
			$V_{DD} = 2.5\text{ V}$		0.33	
		THD + N = 1%, $f = 1\text{ kHz}$ , $R_L = 8\ \Omega$	$V_{DD} = 5\text{ V}$		1.19	W
			$V_{DD} = 3.6\text{ V}$		0.59	
			$V_{DD} = 2.5\text{ V}$		0.26	
THD+N	Total harmonic distortion plus noise	$V_{DD} = 5\text{ V}$ , $P_O = 1\text{ W}$ , $R_L = 8\ \Omega$ , $f = 1\text{ kHz}$		0.19%		
		$V_{DD} = 3.6\text{ V}$ , $P_O = 0.5\text{ W}$ , $R_L = 8\ \Omega$ , $f = 1\text{ kHz}$		0.19%		
		$V_{DD} = 2.5\text{ V}$ , $P_O = 200\text{ mW}$ , $R_L = 8\ \Omega$ , $f = 1\text{ kHz}$		0.20%		
$k_{SVR}$	Supply ripple rejection ratio	$V_{DD} = 3.6\text{ V}$ , Inputs ac-grounded with $C_i = 2\ \mu\text{F}$	$f = 217\text{ Hz}$ , $V_{(RIPPLE)} = 200\text{ mV}_{PP}$		-67	dB
SNR	Signal-to-noise ratio	$V_{DD} = 5\text{ V}$ , $P_O = 1\text{ W}$ , $R_L = 8\ \Omega$ , A-weighted		97		dB
$V_n$	Output voltage noise	$V_{DD} = 3.6\text{ V}$ , $f = 20\text{ Hz to } 20\text{ kHz}$ , Inputs ac-grounded with $C_i = 2\ \mu\text{F}$	No weighting		48	$\mu\text{V}_{RMS}$
			A weighting		36	
CMRR	Common mode rejection ratio	$V_{DD} = 3.6\text{ V}$ , $V_{IC} = 1\text{ V}_{PP}$	$f = 217\text{ Hz}$		-63	dB
$Z_I$	Input impedance		142	150	158	k $\Omega$
	Start-up time from shutdown	$V_{DD} = 3.6\text{ V}$		1		ms

## 7.7 Typical Characteristics

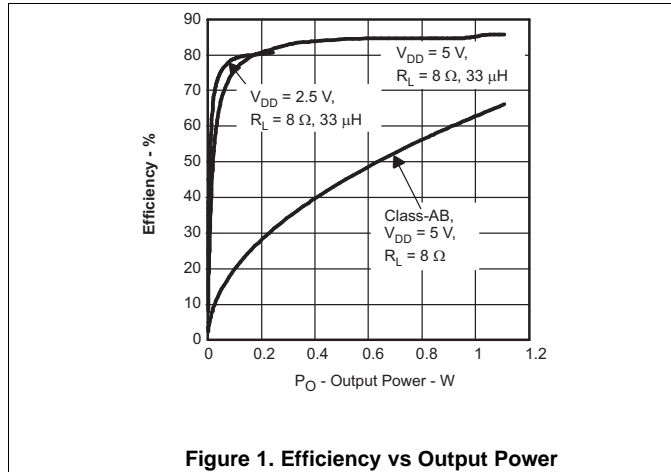

Figure 1. Efficiency vs Output Power

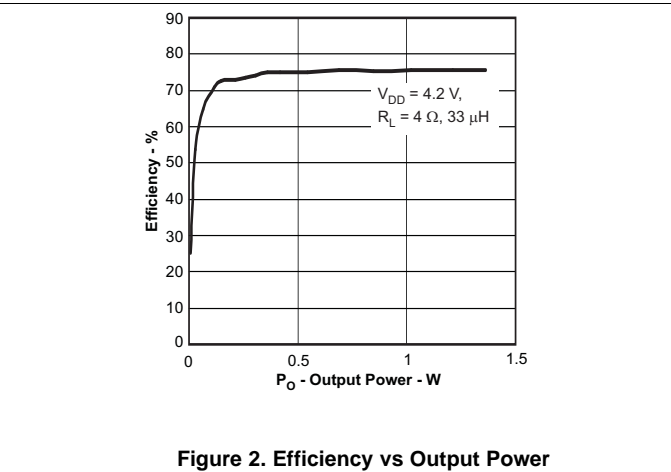

Figure 2. Efficiency vs Output Power

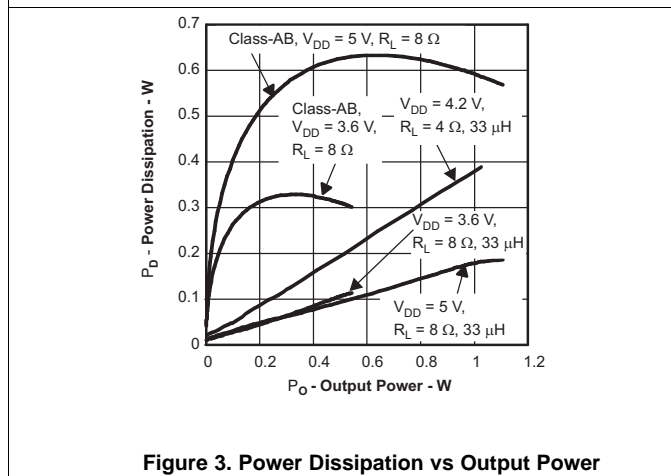

Figure 3. Power Dissipation vs Output Power

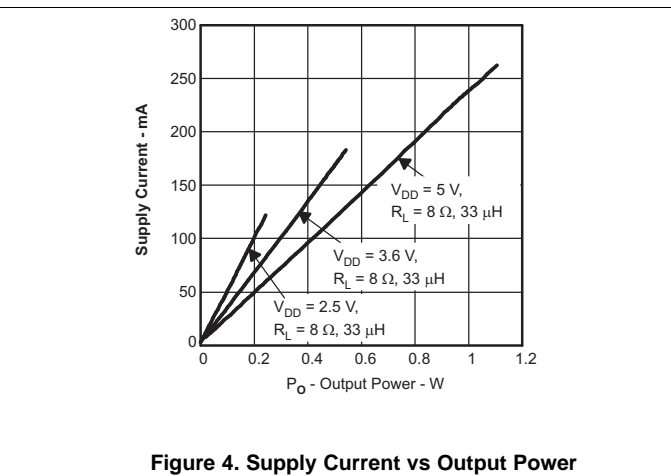

Figure 4. Supply Current vs Output Power

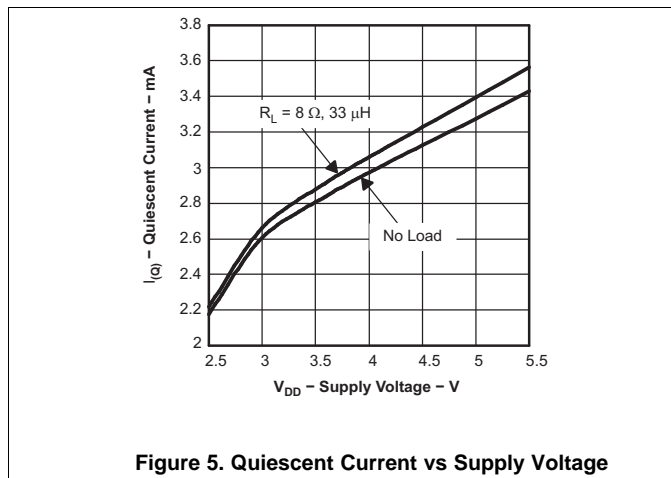

Figure 5. Quiescent Current vs Supply Voltage

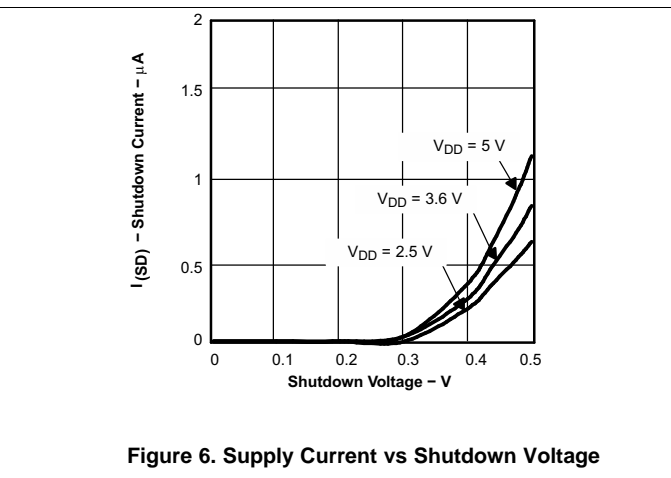

Figure 6. Supply Current vs Shutdown Voltage

Typical Characteristics (continued)

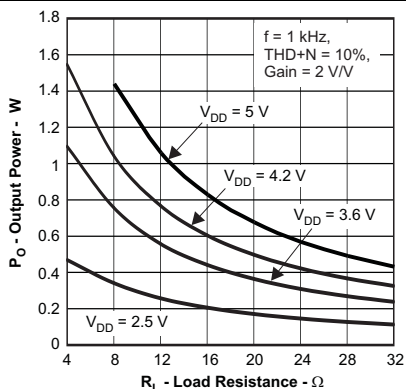

Figure 7. Output Power vs Load Resistance

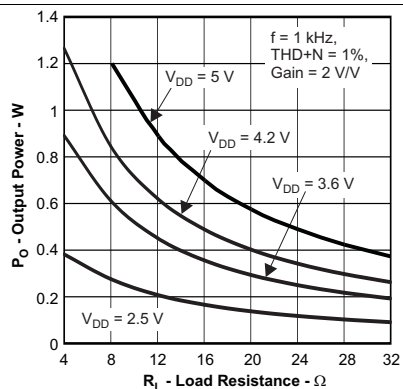

Figure 8. Output Power vs Load Resistance

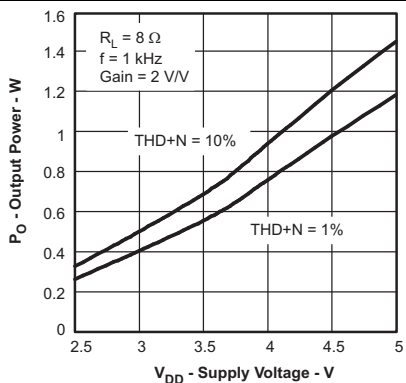

Figure 9. Output Power vs Supply Voltage

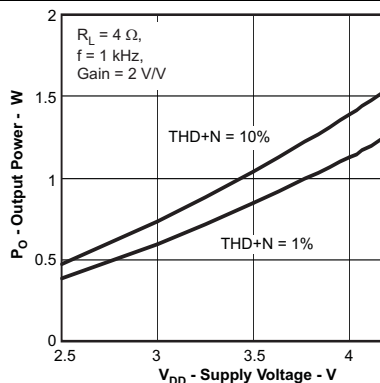

Figure 10. Output Power vs Supply Voltage

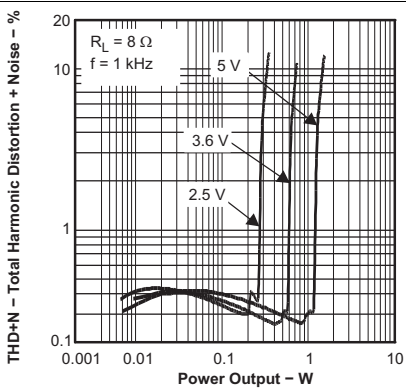

Figure 11. Total Harmonic Distortion + Noise vs Output Power

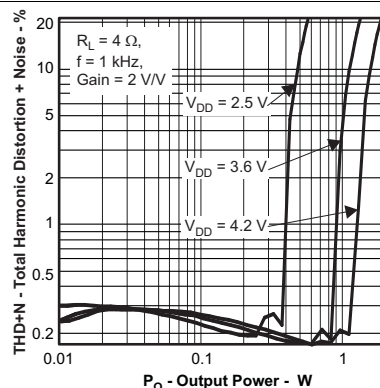

Figure 12. Total Harmonic Distortion + Noise vs Output Power

Typical Characteristics (continued)

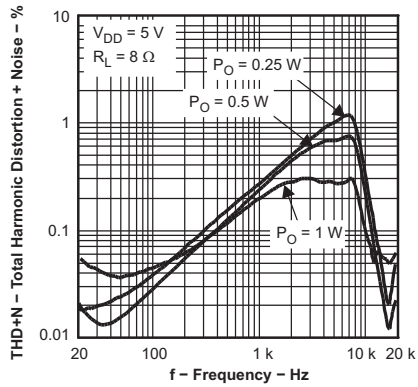

Figure 13. Total Harmonic Distortion + Noise vs Frequency

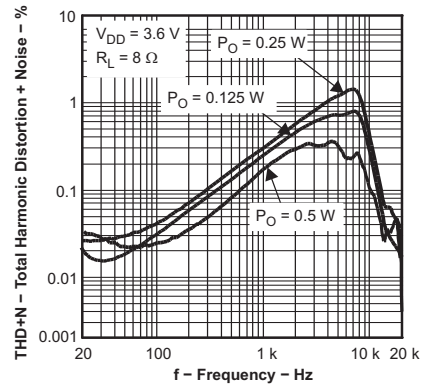

Figure 14. Total Harmonic Distortion + Noise vs Frequency

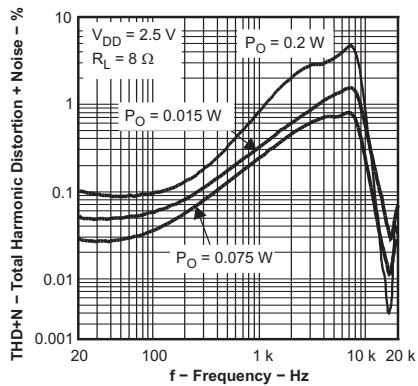

Figure 15. Total Harmonic Distortion + Noise vs Frequency

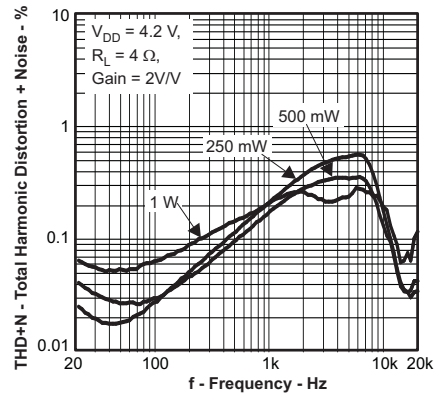

Figure 16. Total Harmonic Distortion + Noise vs Frequency

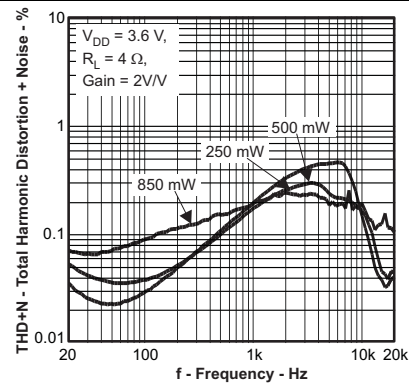

Figure 17. Total Harmonic Distortion + Noise vs Frequency

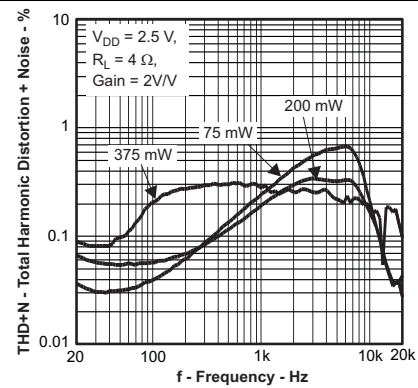

Figure 18. Total Harmonic Distortion + Noise vs Frequency

Typical Characteristics (continued)

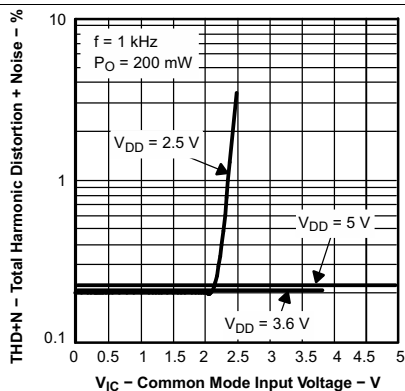

Figure 19. Total Harmonic Distortion + Noise vs Common Mode Input Voltage

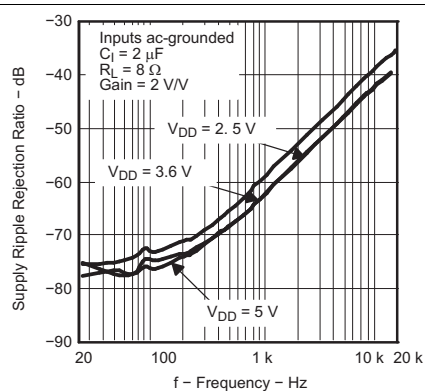

Figure 20. Supply Ripple Rejection Ratio vs Frequency

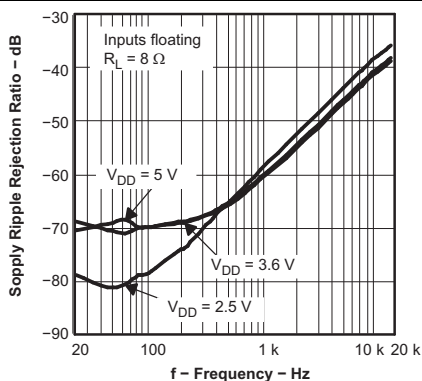

Figure 21. Supply Ripple Rejection Ratio vs Frequency

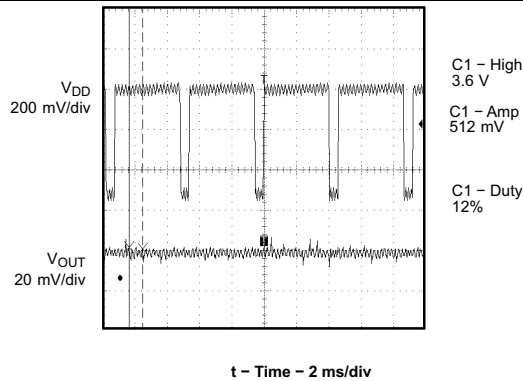

Figure 22. GSM Power Supply Rejection vs Time

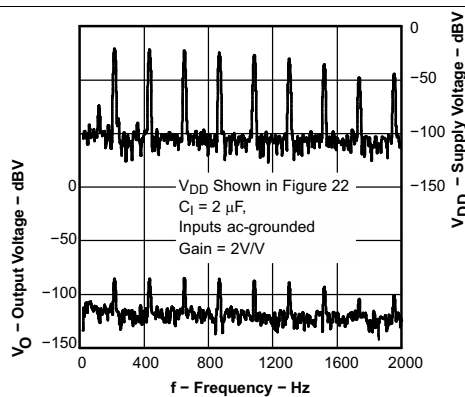

Figure 23. GSM Power Supply Rejection vs Frequency

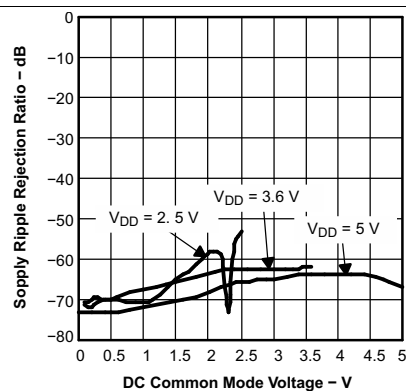
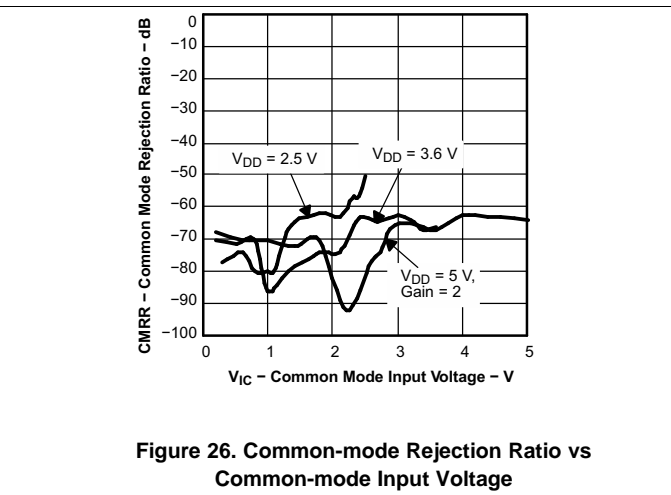
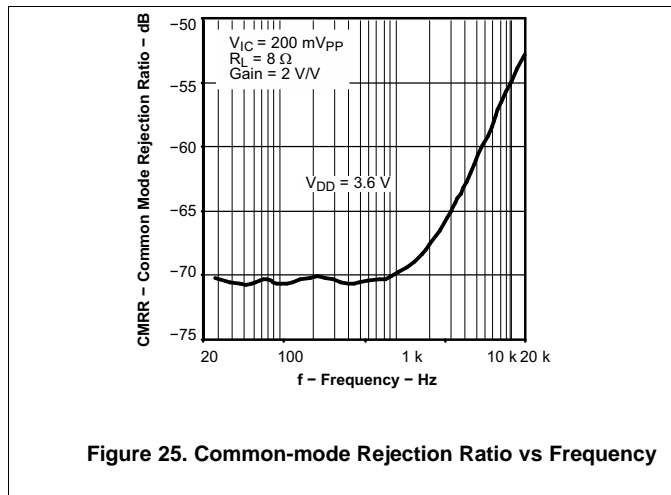

Figure 24. Supply Ripple Rejection Ratio vs DC Common Mode Voltage

### Typical Characteristics (continued)



## 8 Parameter Measurement Information

All parameters are measured according to the conditions described in the [Specifications](#) section.

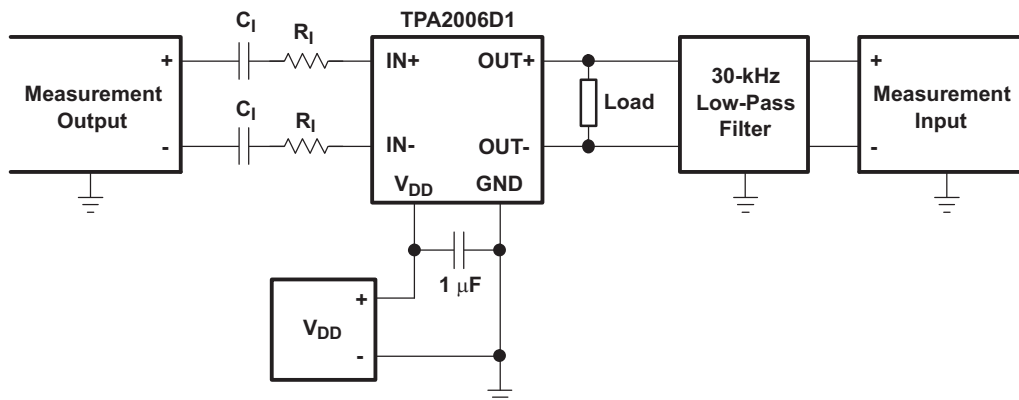

- A.  $C_1$  is shorted for any common-mode input voltage measurement.
- B. A 33- $\mu$ H inductor is placed in series with the load resistor to emulate a small speaker for efficiency measurements.
- C. The 30-kHz low-pass filter is required even if the analyzer has an internal low-pass filter. An RC low-pass filter (100  $\Omega$ , 47 nF) is used on each output for the data sheet graphs.

**Figure 27. Test Set-up for Graphs**

## 9 Detailed Description

### 9.1 Overview

The TPA2006D1 device is a high-efficiency, filter-free, Class-D audio amplifier capable of delivering up to 1.45 W into 8-Ω loads with 5-V power supply. Shutdown control is fully compatible with 1.8-V logic levels.

The fully differential design of this amplifier avoids the usage of bypass capacitors and the improved CMRR eliminates the usage of input coupling capacitors. This makes the device size a perfect choice for small, portable applications as only three external components are required.

The advanced modulation used in the TPA2006D1 device PWM output stage eliminates the need for an output filter.

### 9.2 Functional Block Diagram

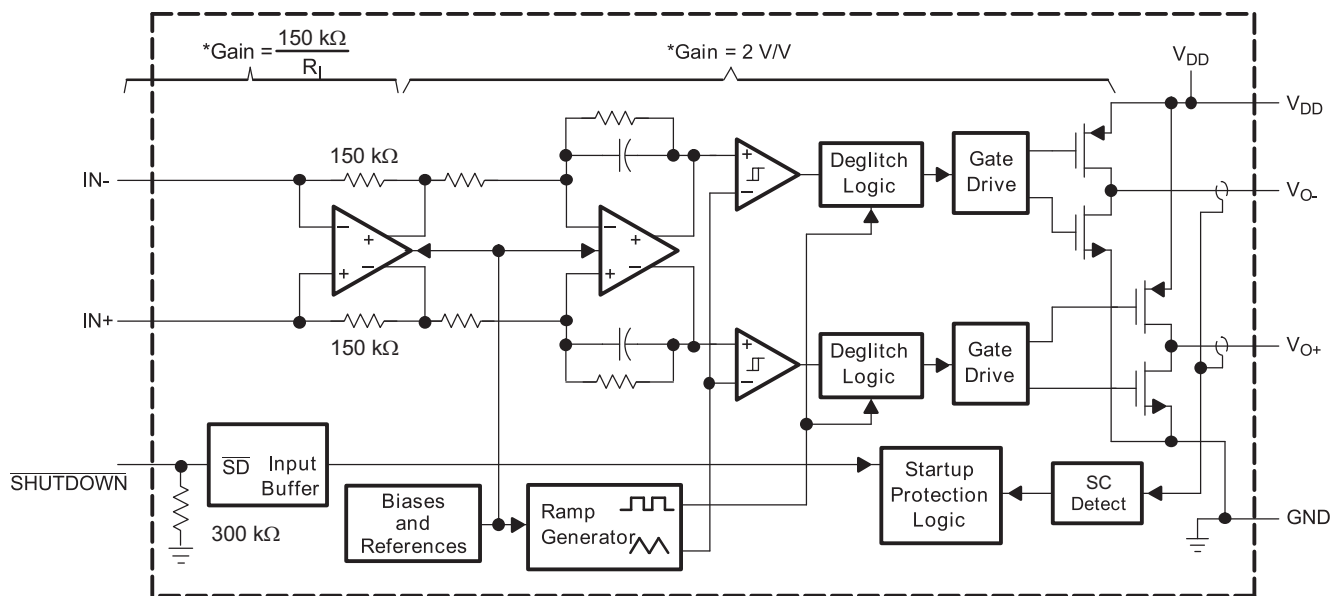

Notes:

$$* \text{ Total gain} = 2 \times \frac{150 \text{ k}\Omega}{R_1}$$

### 9.3 Feature Description

#### 9.3.1 Fully Differential Amplifier

The TPA2006D1 device is a fully differential amplifier with differential inputs and outputs. The fully differential amplifier consists of a differential amplifier and a common-mode amplifier. The differential amplifier ensures that the amplifier outputs a differential voltage on the output that is equal to the differential input times the gain. The common-mode feedback ensures that the common-mode voltage at the output is biased around  $V_{DD}/2$  regardless of the common-mode voltage at the input. The fully differential TPA2006D1 device can still be used with a single-ended input; however, the TPA2006D1 device must be used with differential inputs when in a noisy environment, like a wireless handset, to ensure maximum noise rejection.

##### 9.3.1.1 Advantages of Fully Differential Amplifiers

- Input-coupling capacitors not required:
  - The fully differential amplifier allows the inputs to be biased at voltage other than mid-supply. For example, if a codec has a mid-supply lower than the mid-supply of the TPA2006D1 device, the common-mode feedback circuit will adjust, and the TPA2006D1 device outputs will still be biased at mid-supply of the TPA2006D1 device. The inputs of the TPA2006D1 device can be biased from 0.5 V to  $V_{DD} - 0.8$  V. If the inputs are biased outside of that range, input-coupling capacitors are required.

## Feature Description (continued)

- Mid-supply bypass capacitor,  $C_{(BYPASS)}$ , not required:
  - The fully differential amplifier does not require a bypass capacitor. This is because any shift in the midsupply affects both positive and negative channels equally and cancels at the differential output.
- Better RF-immunity:
  - GSM handsets save power by turning on and shutting off the RF transmitter at a rate of 217 Hz. The transmitted signal is picked-up on input and output traces. The fully differential amplifier cancels the signal much better than the typical audio amplifier.

### 9.3.2 Efficiency and Thermal Information

The maximum ambient temperature depends on the heat-sinking ability of the PCB system. The derating factor for the DRB package is shown in the dissipation rating table. Converting this to  $\theta_{JA}$ :

$$\theta_{JA} = \frac{1}{\text{Derating Factor}} = \frac{1}{0.0218} = 45.9^{\circ}\text{C/W} \quad (1)$$

Given  $\theta_{JA}$  of 45.9°C/W, the maximum allowable junction temperature of 125°C, and the maximum internal dissipation of 0.2 W ( $P_o = 1.45$  W, 8-Ω load, 5-V supply, from [Figure 3](#)), the maximum ambient temperature can be calculated with [Equation 2](#).

$$T_{A\text{Max}} = T_{J\text{Max}} - \theta_{JA}P_{D\text{max}} = 125 - 45.9(0.2) = 115.8^{\circ}\text{C} \quad (2)$$

[Equation 2](#) shows that the calculated maximum ambient temperature is 115.8°C at maximum power dissipation with a 5-V supply and 8-Ω a load, see [Figure 3](#). The TPA2006D1 device is designed with thermal protection that turns the device off when the junction temperature surpasses 150°C to prevent damage to the device.

### 9.3.3 Eliminating the Output Filter With the TPA2006D1 Device

This section focuses on why the user can eliminate the output filter with the TPA2006D1 device.

#### 9.3.3.1 Effect on Audio

The class-D amplifier outputs a pulse-width modulated (PWM) square wave, which is the sum of the switching waveform and the amplified input audio signal. The human ear acts as a band-pass filter such that only the frequencies between approximately 20 Hz and 20 kHz are passed. The switching frequency components are much greater than 20 kHz, so the only signal heard is the amplified input audio signal.

#### 9.3.3.2 Traditional Class-D Modulation Scheme

The traditional class-D modulation scheme, which is used in the TPA005Dxx family, has a differential output where each output is 180 degrees out of phase and changes from ground to the supply voltage,  $V_{DD}$ . Therefore, the differential pre-filtered output varies between positive and negative  $V_{DD}$ , where filtered 50% duty cycle yields 0 volts across the load. The traditional class-D modulation scheme with voltage and current waveforms is shown in [Figure 28](#). Note that even at an average of 0 volts across the load (50% duty cycle), the current to the load is high causing a high loss and thus causing a high supply current.

Feature Description (continued)

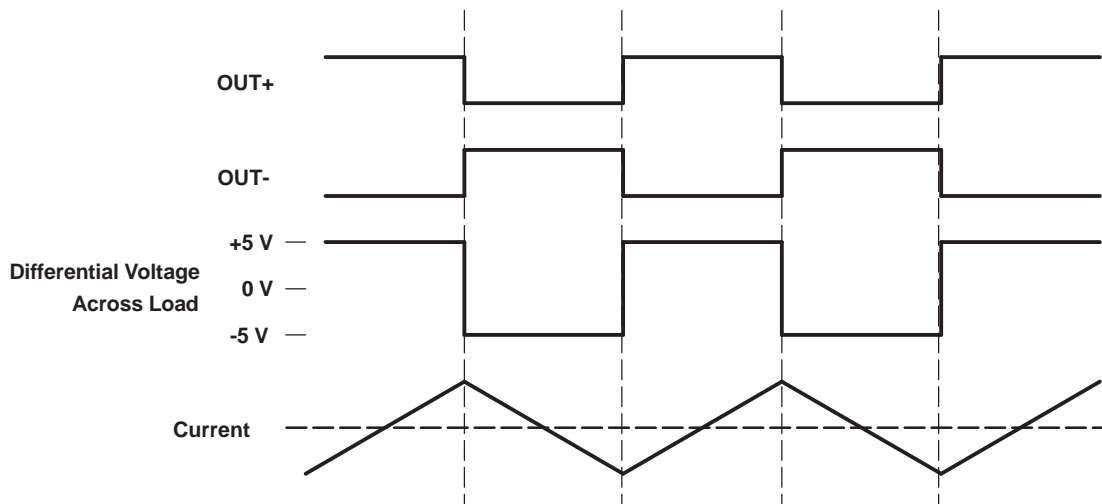

Figure 28. Traditional Class-D Modulation Scheme's Output Voltage and Current Waveforms into an Inductive Load With no Input

9.3.3.3 TPA2006D1 Device Modulation Scheme

The TPA2006D1 device uses a modulation scheme that still has each output switching from 0 to the supply voltage. However, OUT+ and OUT- are now in phase with each other with no input. The duty cycle of OUT+ is greater than 50% and OUT- is less than 50% for positive voltages. The duty cycle of OUT+ is less than 50% and OUT- is greater than 50% for negative voltages. The voltage across the load sits at 0 volts throughout most of the switching period greatly reducing the switching current, which reduces any  $I^2R$  losses in the load.

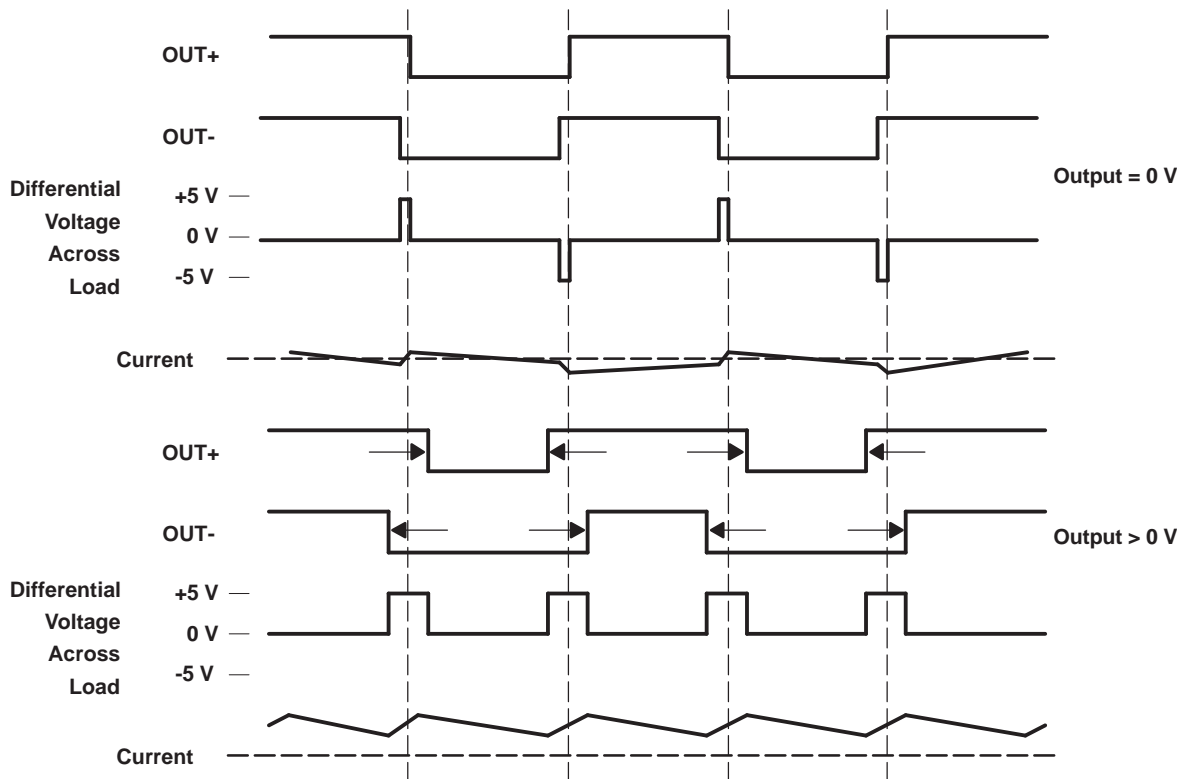

Figure 29. The TPA2006D1 Device Output Voltage and Current Waveforms into an Inductive Load

## Feature Description (continued)

### 9.3.3.4 Efficiency: Why A Filter is Needed With the Traditional Class-D Modulation Scheme

The main reason that the traditional class-D amplifier needs an output filter is that the switching waveform results in maximum current flow. This causes more loss in the load, which causes lower efficiency. The ripple current is large for the traditional modulation scheme because the ripple current is proportional to voltage multiplied by the time at that voltage. The differential voltage swing is  $2 \times V_{DD}$  and the time at each voltage is half the period for the traditional modulation scheme. An ideal LC filter is needed to store the ripple current from each half cycle for the next half cycle, while any resistance causes power dissipation. The speaker is both resistive and reactive, whereas an LC filter is almost purely reactive.

The TPA2006D1 device modulation scheme has little loss in the load without a filter because the pulses are short and the change in voltage is  $V_{DD}$  instead of  $2 \times V_{DD}$ . As the output power increases, the pulses widen making the ripple current larger. Ripple current could be filtered with an LC filter for increased efficiency, but for most applications the filter is not needed.

An LC filter with a cutoff frequency less than the class-D switching frequency allows the switching current to flow through the filter instead of the load. The filter has less resistance than the speaker that results in less power dissipated, which increases efficiency.

### 9.3.3.5 Effects of Applying a Square Wave into a Speaker

If the amplitude of a square wave is high enough and the frequency of the square wave is within the bandwidth of the speaker, a square wave could cause the voice coil to jump out of the air gap and/or scar the voice coil. A 250-kHz switching frequency, however, is not significant because the speaker cone movement is proportional to  $1/f^2$  for frequencies beyond the audio band. Therefore, the amount of cone movement at the switching frequency is small. However, damage could occur to the speaker if the voice coil is not designed to handle the additional power. To size the speaker for added power, the ripple current dissipated in the load needs to be calculated by subtracting the theoretical supplied power,  $P_{SUP\_THEORETICAL}$ , from the actual supply power,  $P_{SUP}$ , at maximum output power,  $P_{OUT}$ . The switching power dissipated in the speaker is the inverse of the measured efficiency,  $\eta_{MEASURED}$ , minus the theoretical efficiency,  $\eta_{THEORETICAL}$ .

$$P_{SPKR} = P_{SUP} - P_{SUP\_THEORETICAL} \quad (\text{at max output power}) \quad (3)$$

$$P_{SPKR} = \frac{P_{SUP}}{P_{OUT}} - \frac{P_{SUP\_THEORETICAL}}{P_{OUT}} \quad (\text{at max output power}) \quad (4)$$

$$P_{SPKR} = P_{OUT} \left( \frac{1}{\eta_{MEASURED}} - \frac{1}{\eta_{THEORETICAL}} \right) \quad (\text{at max output power}) \quad (5)$$

$$\eta_{THEORETICAL} = \frac{R_L}{R_L + 2r_{DS(on)}} \quad (\text{at max output power}) \quad (6)$$

The maximum efficiency of the TPA2006D1 device with a 3.6-V supply and an 8-Ω load is 86% from [Equation 6](#). Using [Equation 5](#) with the efficiency at maximum power (84%), we see that there is an additional 17 mW dissipated in the speaker. The added power dissipated in the speaker is not an issue as long as it is taken into account when choosing the speaker.

## Feature Description (continued)

### 9.3.3.6 When to Use an Output Filter

Design the TPA2006D1 device without an output filter if the traces from amplifier to speaker are short. The TPA2006D1 device passed FCC and CE radiated emissions with no shielding with speaker trace wires 100 mm long or less. Wireless handsets and PDAs are great applications for class-D without a filter.

A ferrite bead filter can often be used if the design is failing radiated emissions without an LC filter, and the frequency sensitive circuit is greater than 1 MHz. This is good for circuits that just have to pass FCC and CE because FCC and CE only test radiated emissions greater than 30 MHz. If choosing a ferrite bead, choose one with high impedance at high frequencies, but low impedance at low frequencies.

Use an LC output filter if there are low frequency (< 1 MHz) EMI sensitive circuits and/or there are long leads from amplifier to speaker.

Figure 30 and Figure 31 show typical ferrite bead and LC output filters.

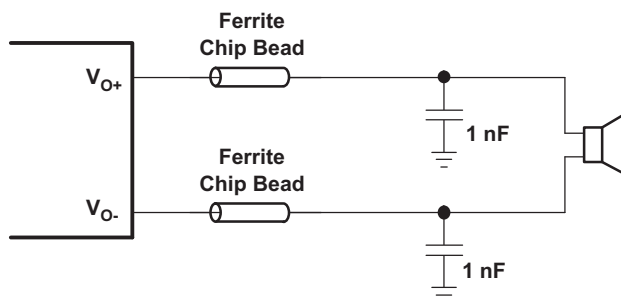

Figure 30. Typical Ferrite Chip Bead Filter (Chip Bead Example: NEC/Tokin: N2012ZPS121)

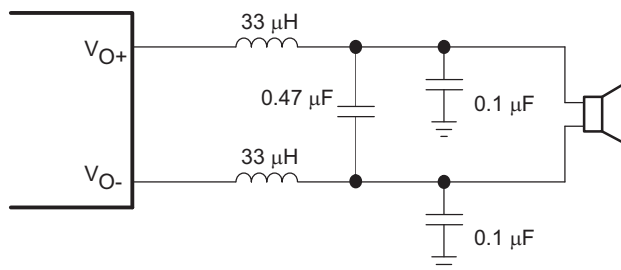

Figure 31. Typical LC Output Filter, Cutoff Frequency of 27 kHz

### 9.3.4 Thermal and Short-Circuit Protection

The TPA2006D1 device features thermal and short-circuit protection. When the protection circuit is triggered, the device will enter in shutdown mode, setting the outputs of the device into High Impedance. Thermal protection turns the device off when the junction temperature surpasses 150°C to prevent damage to the device.

## 9.4 Device Functional Modes

### 9.4.1 Summing Input Signals with the TPA2006D1 Device

Most wireless phones or PDAs need to sum signals at the audio power amplifier or just have two signal sources that need separate gain. The TPA2006D1 device makes it easy to sum signals or use separate signal sources with different gains. Many phones now use the same speaker for the earpiece and ringer, where the wireless phone would require a much lower gain for the phone earpiece than for the ringer. PDAs and phones that have stereo headphones require summing of the right and left channels to output the stereo signal to the mono speaker.

**Device Functional Modes (continued)**
**9.4.1.1 Summing Two Differential Input Signals**

Two extra resistors are needed for summing differential signals (a total of 5 components). The gain for each input source can be set independently (see [Equation 7](#) and [Equation 8](#), and [Figure 32](#)).

$$\text{Gain 1} = \frac{V_O}{V_{I1}} = \frac{2 \times 150 \text{ k}\Omega}{R_{I1}} \left( \frac{\text{V}}{\text{V}} \right) \quad (7)$$

$$\text{Gain 2} = \frac{V_O}{V_{I2}} = \frac{2 \times 150 \text{ k}\Omega}{R_{I2}} \left( \frac{\text{V}}{\text{V}} \right) \quad (8)$$

If summing left and right inputs with a gain of 1 V/V, use  $R_{I1} = R_{I2} = 300 \text{ k}\Omega$ .

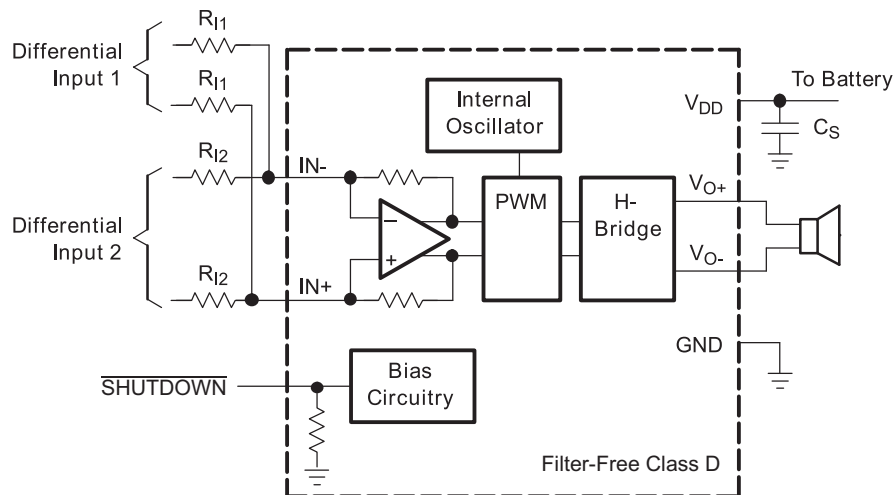

**Figure 32. Application Schematic With TPA2006D1 Device Summing Two Differential Inputs**

## Device Functional Modes (continued)

### 9.4.1.2 Summing a Differential Input Signal and a Single-Ended Input Signal

Figure 33 shows how to sum a differential input signal and a single-ended input signal. Ground noise can couple in through IN+ with this method. It is better to use differential inputs. The corner frequency of the single-ended input is set by C<sub>I2</sub>, shown in Equation 11. To assure that each input is balanced, the single-ended input must be driven by a low-impedance source even if the input is not in use

$$\text{Gain 1} = \frac{V_O}{V_{I1}} = \frac{2 \times 150 \text{ k}\Omega}{R_{I1}} \left( \frac{V}{V} \right) \quad (9)$$

$$\text{Gain 2} = \frac{V_O}{V_{I2}} = \frac{2 \times 150 \text{ k}\Omega}{R_{I2}} \left( \frac{V}{V} \right) \quad (10)$$

$$C_{I2} = \frac{1}{(2\pi R_{I2} f_{c2})} \quad (11)$$

If summing a ring tone and a phone signal, the phone signal must use a differential input signal while the ring tone might be limited to a single-ended signal.

The high pass corner frequency of the single-ended input is set by C<sub>I2</sub>. If the desired corner frequency is less than 20 Hz:

$$C_{I2} > \frac{1}{(2\pi 150 \text{ k}\Omega 20 \text{ Hz})} \quad (12)$$

$$C_{I2} > 53 \text{ nF} \quad (13)$$

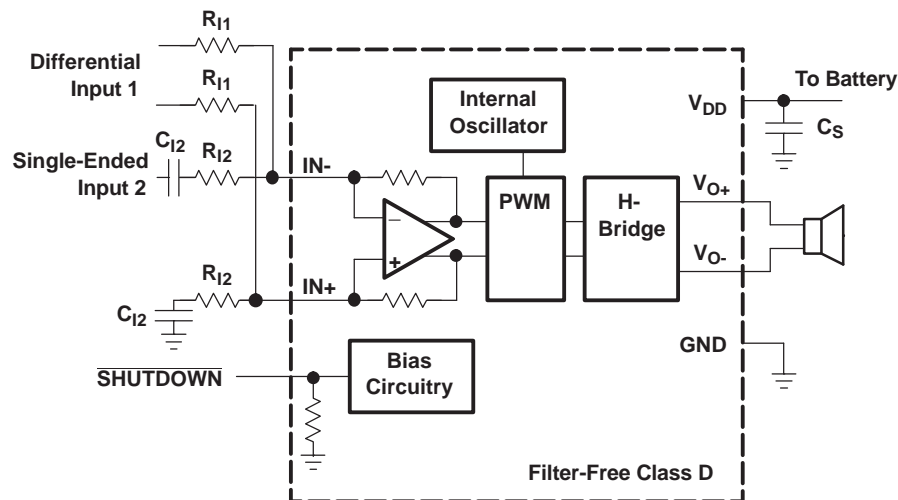

Figure 33. Application Schematic With TPA2006D1 Device Summing Differential Input and Single-Ended Input Signals

### 9.4.1.3 Summing Two Single-Ended Input Signals

Four resistors and three capacitors are needed for summing single-ended input signals. The gain and corner frequencies ( $f_{c1}$  and  $f_{c2}$ ) for each input source can be set independently (see Equation 14 through Equation 17, and Figure 34). Resistor, R<sub>P</sub>, and capacitor, C<sub>P</sub>, are needed on the IN+ terminal to match the impedance on the IN- terminal. The single-ended inputs must be driven by low impedance sources even if one of the inputs is not outputting an AC signal.

$$\text{Gain 1} = \frac{V_O}{V_{I1}} = \frac{2 \times 150 \text{ k}\Omega}{R_{I1}} \left( \frac{V}{V} \right) \quad (14)$$

**Device Functional Modes (continued)**

$$\text{Gain 2} = \frac{V_O}{V_{I2}} = \frac{2 \times 150 \text{ k}\Omega}{R_{I2}} \quad \left(\frac{V}{V}\right) \quad (15)$$

$$C_{I1} = \frac{1}{(2\pi R_{I1} f_{c1})} \quad (16)$$

$$C_{I2} = \frac{1}{(2\pi R_{I2} f_{c2})} \quad (17)$$

$$C_P = C_{I1} + C_{I2} \quad (18)$$

$$R_P = \frac{R_{I1} \times R_{I2}}{(R_{I1} + R_{I2})} \quad (19)$$

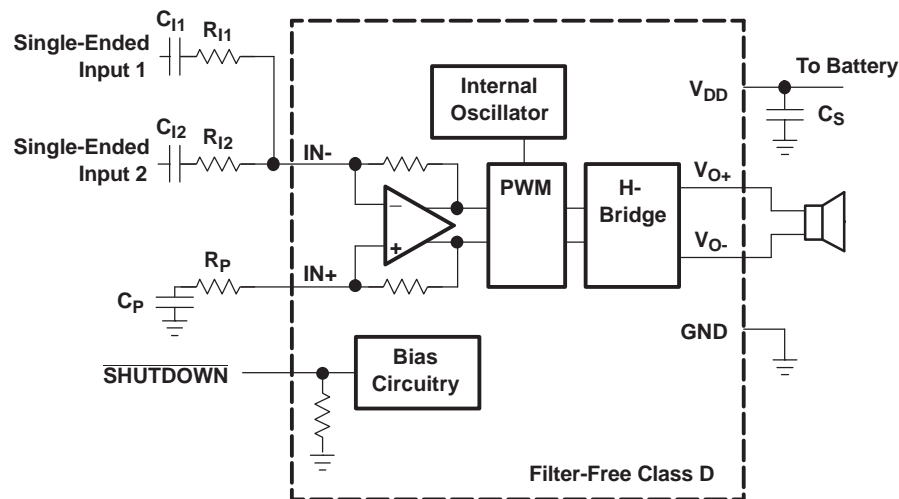

**Figure 34. Application Schematic With TPA2006D1 Device Summing Two Single-Ended Inputs**

**9.4.2 Shutdown Mode**

The TPA2006D1 device can be put in shutdown mode when asserting SHUTDOWN pin to a logic LOW. While in shutdown mode, the device output stage is turned off and set into High Impedance, making the current consumption very low. The device exits shutdown mode when a HIGH logic level is applied to SHUTDOWN pin.

## 10 Application and Implementation

### NOTE

Information in the following applications sections is not part of the TI component specification, and TI does not warrant its accuracy or completeness. TI's customers are responsible for determining suitability of components for their purposes. Customers should validate and test their design implementation to confirm system functionality.

### 10.1 Application Information

These typical connection diagrams highlight the required external components and system level connections for proper operation of the device in several popular use cases. Each of these configurations can be realized using the evaluation modules (EVMs) for the device. These flexible modules allow full evaluation of the device in the most common modes of operation. Any design variation can be supported by TI through schematic and layout reviews. Visit <http://e2e.ti.com> for design assistance and join the audio amplifier discussion forum for additional information.

### 10.2 Typical Application

Figure 35 details the recommended component selection and board configurations for the TPA2006D1 device (see also [System Examples](#)).

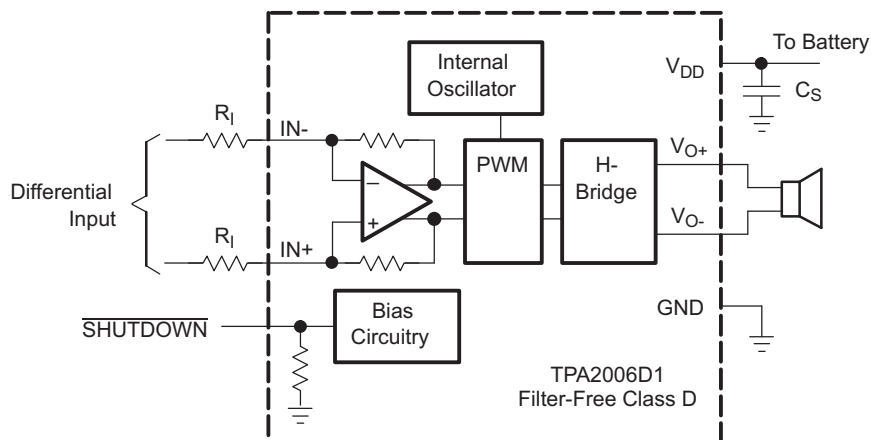

Figure 35. Typical TPA2006D1 Device Application Schematic With Differential Input for a Wireless Phone

#### 10.2.1 Design Requirements

For typical mono filter-free Class-D audio power amplifier applications, use the parameters listed in [Table 1](#).

Table 1. Design Parameters

PARAMETER	EXAMPLE
Power supply	5 V
Shutdown input	High > 1.3 V
	Low < 0.35 V
Speaker	8 Ω

## 10.2.2 Detailed Design Procedure

### 10.2.2.1 Component Selection

Figure 35 shows the TPA2006D1 device typical schematic with differential inputs and Figure 38 shows the TPA2006D1 device with differential inputs and input capacitors, and Figure 39 shows the TPA2006D1 device with single-ended inputs. Differential inputs should be used whenever possible because the single-ended inputs are much more susceptible to noise.

**Table 2. Typical Component Values**

REF DES	VALUE	EIA SIZE	MANUFACTURER	PART NUMBER
R <sub>I</sub>	150 kΩ (±0.5%)	0402	Panasonic	ERJ2RHD154V
C <sub>S</sub>	1 μF (+22%, -80%)	0402	Murata	GRP155F50J105Z
C <sub>I</sub> <sup>(1)</sup>	3.3 nF (±10%)	0201	Murata	GRP033B10J332K

(1) C<sub>I</sub> is only needed for single-ended input or if V<sub>ICM</sub> is not between 0.5 V and V<sub>DD</sub> – 0.8 V. C<sub>I</sub> = 3.3 nF (with R<sub>I</sub> = 150 kΩ) gives a high-pass corner frequency of 321 Hz.

### 10.2.2.2 Input Resistors (R<sub>I</sub>)

The input resistors (R<sub>I</sub>) set the gain of the amplifier according to Equation 20.

$$\text{Gain} = \frac{2 \times 150 \text{ k}\Omega}{R_I} \left( \frac{V}{V} \right) \quad (20)$$

Resistor matching is important in fully differential amplifiers. The balance of the output on the reference voltage depends on matched ratios of the resistors. CMRR, PSRR, and cancellation of the second harmonic distortion diminish if resistor mismatch occurs. Therefore, it is recommended to use 1% tolerance resistors or better to keep the performance optimized. Matching is more important than overall tolerance. Resistor arrays with 1% matching can be used with a tolerance greater than 1%.

Place the input resistors close to the TPA2006D1 device to limit noise injection on the high-impedance nodes.

For optimal performance the gain must be set to 2 V/V or lower. Lower gain allows the TPA2006D1 device to operate at its best and keeps a high voltage at the input making the inputs less susceptible to noise.

### 10.2.2.3 Decoupling Capacitor (C<sub>S</sub>)

The TPA2006D1 device is a high-performance class-D audio amplifier that requires adequate power supply decoupling to ensure the efficiency is high and total harmonic distortion (THD) is low. For higher frequency transients, spikes, or digital hash on the line, a good low equivalent-series-resistance (ESR) ceramic capacitor, typically 1 μF, placed as close as possible to the device V<sub>DD</sub> lead works best. Placing this decoupling capacitor close to the device is important for the efficiency of the class-D amplifier, because any resistance or inductance in the trace between the device and the capacitor can cause a loss in efficiency. For filtering lower-frequency noise signals, a 10-μF or greater capacitor placed near the audio power amplifier would also help, but it is not required in most applications because of the high PSRR of this device.

### 10.2.2.4 Input Capacitors (C<sub>I</sub>)

The TPA2006D1 device does not require input coupling capacitors if the design uses a differential source that is biased from 0.5 V to V<sub>DD</sub> – 0.8 V (shown in Figure 35). If the input signal is not biased within the recommended common-mode input range, if needing to use the input as a high pass filter (shown in Figure 38), or if using a single-ended source (shown in Figure 39), input coupling capacitors are required.

The input capacitors and input resistors form a high-pass filter with the corner frequency, f<sub>c</sub>, determined in Equation 21.

$$f_c = \frac{1}{(2\pi R_I C_I)} \quad (21)$$

The value of the input capacitor is important to consider as it directly affects the bass (low frequency) performance of the circuit. Speakers in wireless phones cannot usually respond well to low frequencies, so the corner frequency can be set to block low frequencies in this application.

Equation 22 is reconfigured to solve for the input coupling capacitance.

$$C_I = \frac{1}{(2\pi R_I f_C)} \tag{22}$$

If the corner frequency is within the audio band, the capacitors must have a tolerance of ±10% or better, because any mismatch in capacitance causes an impedance mismatch at the corner frequency and below, and causes pop. Any capacitor in the audio path should have a rating of X7R or better.

For a flat low-frequency response, use large input coupling capacitors (1 µF). However, in a GSM phone the ground signal is fluctuating at 217 Hz, but the signal from the codec does not have the same 217-Hz fluctuation. The difference between the two signals is amplified, sent to the speaker, and heard as a 217-Hz hum.

### 10.2.3 Application Curves

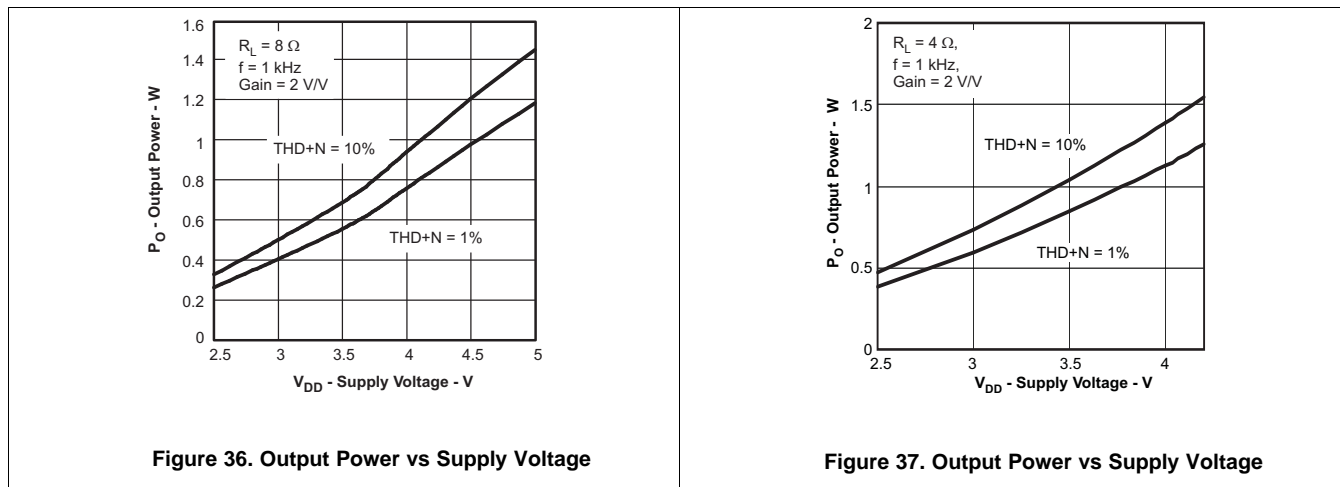

## 10.3 System Examples

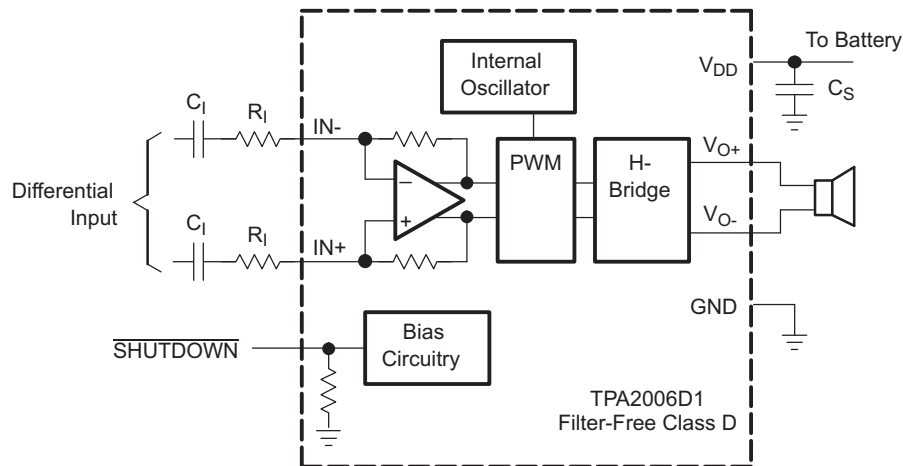

**Figure 38. TPA2006D1 Device Application Schematic With Differential Input and Input Capacitors**

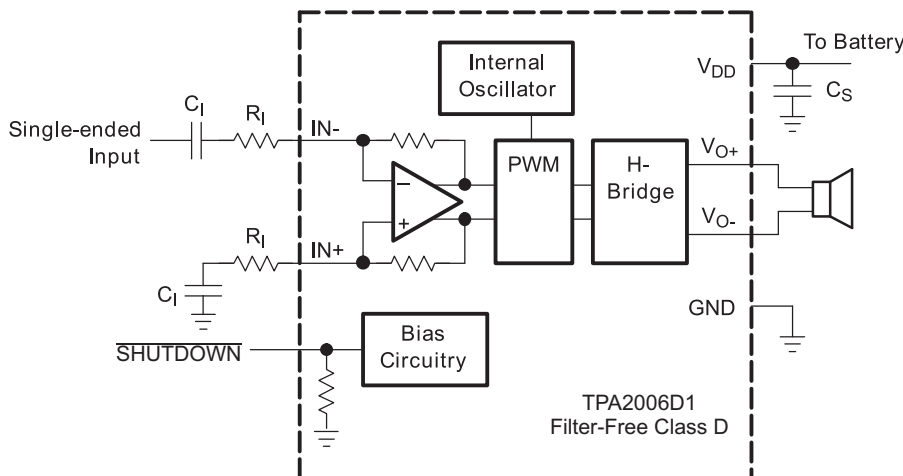

**Figure 39. TPA2006D1 Device Application Schematic With Single-Ended Input**

## 11 Power Supply Recommendations

The TPA2006D1 device is designed to operate from an input voltage supply range between 2.5 V and 5.2 V. Therefore, the output voltage range of power supply Must be within this range and well regulated. The current capability of upper power should not exceed the maximum current limit of the power switch.

### 11.1 Power Supply Decoupling Capacitors

The TPA2006D1 device requires adequate power supply decoupling to ensure a high-efficiency operation with low total harmonic distortion (THD).

Place a low equivalent-series-resistance (ESR) ceramic capacitor, typically 0.1  $\mu\text{F}$ , within 2 mm of the  $V_{\text{DD}}$  pin. This choice of capacitor and placement helps with higher frequency transients, spikes, or digital hash on the line. In addition to the 0.1- $\mu\text{F}$  ceramic capacitor, it is recommended to place a 2.2- $\mu\text{F}$  to 10- $\mu\text{F}$  capacitor on the  $V_{\text{DD}}$  supply trace. This larger capacitor acts as a charge reservoir, providing energy faster than the board supply, thus helping to prevent any droop in the supply voltage.

## 12 Layout

### 12.1 Layout Guidelines

Place all the external components close to the TPA2006D1 device. The input resistors need to be close to the TPA2006D1 device input pins so noise does not couple on the high impedance nodes between the input resistors and the input amplifier of the TPA2006D1 device. Placing the decoupling capacitor,  $C_S$ , close to the TPA2006D1 device is important for the efficiency of the class-D amplifier. Any resistance or inductance in the trace between the device and the capacitor can cause a loss in efficiency.

### 12.2 Layout Example

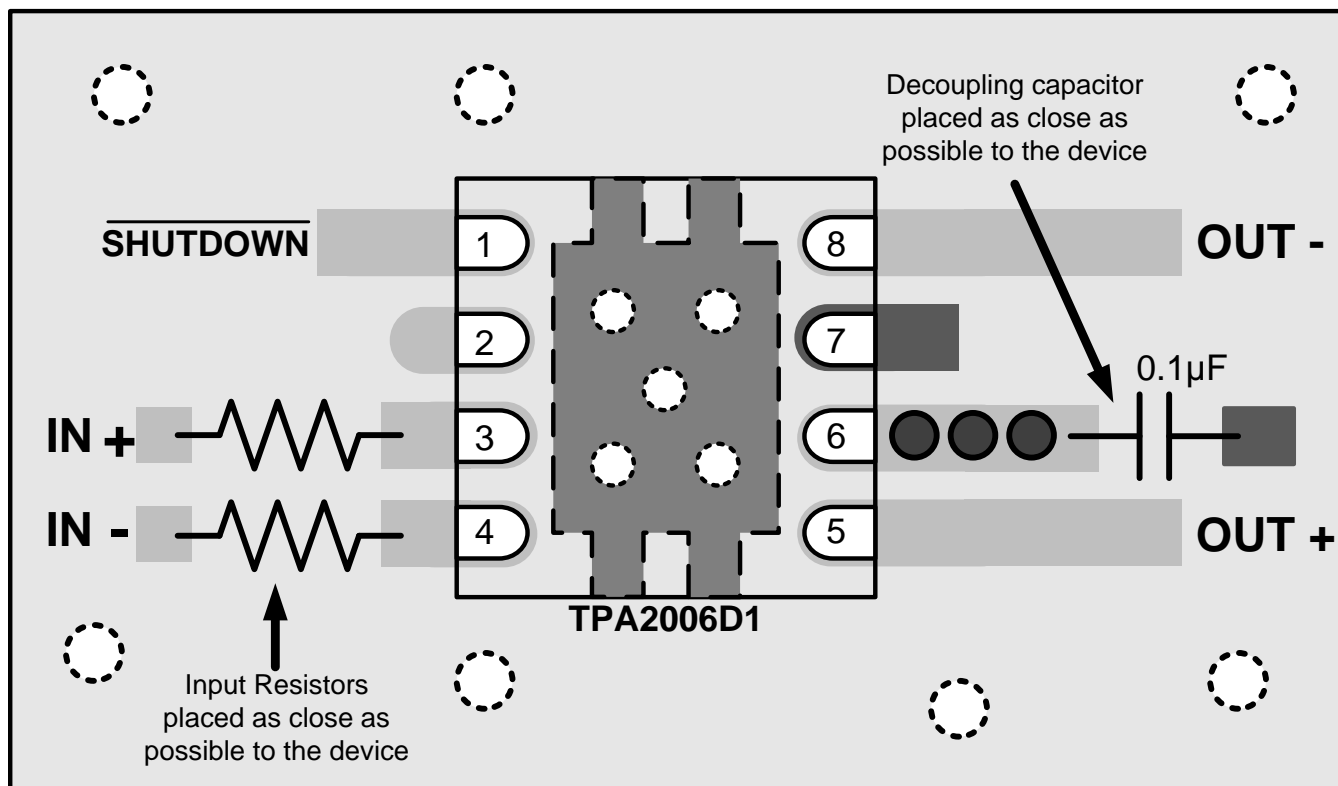

Figure 40. TPA2006D1 Device DRB Package Layout Example

## 13 Device and Documentation Support

### 13.1 Community Resources

The following links connect to TI community resources. Linked contents are provided "AS IS" by the respective contributors. They do not constitute TI specifications and do not necessarily reflect TI's views; see TI's [Terms of Use](#).

**TI E2E™ Online Community** *TI's Engineer-to-Engineer (E2E) Community*. Created to foster collaboration among engineers. At [e2e.ti.com](http://e2e.ti.com), you can ask questions, share knowledge, explore ideas and help solve problems with fellow engineers.

**Design Support** *TI's Design Support* Quickly find helpful E2E forums along with design support tools and contact information for technical support.

### 13.2 Trademarks

E2E is a trademark of Texas Instruments.  
All other trademarks are the property of their respective owners.

### 13.3 Electrostatic Discharge Caution



These devices have limited built-in ESD protection. The leads should be shorted together or the device placed in conductive foam during storage or handling to prevent electrostatic damage to the MOS gates.

### 13.4 Glossary

[SLYZ022](#) — *TI Glossary*.

This glossary lists and explains terms, acronyms, and definitions.

## 14 Mechanical, Packaging, and Orderable Information

The following pages include mechanical, packaging, and orderable information. This information is the most current data available for the designated devices. This data is subject to change without notice and revision of this document. For browser-based versions of this data sheet, refer to the left-hand navigation.

## PACKAGING INFORMATION

Orderable Device	Status (1)	Package Type	Package Drawing	Pins	Package Qty	Eco Plan (2)	Lead/Ball Finish (6)	MSL Peak Temp (3)	Op Temp (°C)	Device Marking (4/5)	Samples
TPA2006D1DRBR	ACTIVE	SON	DRB	8	3000	Green (RoHS & no Sb/Br)	CU NIPDAU	Level-2-260C-1 YEAR	-40 to 85	BTQ	<a href="#">Samples</a>
TPA2006D1DRBRG4	ACTIVE	SON	DRB	8	3000	Green (RoHS & no Sb/Br)	CU NIPDAU	Level-2-260C-1 YEAR	-40 to 85	BTQ	<a href="#">Samples</a>
TPA2006D1DRBT	ACTIVE	SON	DRB	8	250	Green (RoHS & no Sb/Br)	CU NIPDAU	Level-2-260C-1 YEAR	-40 to 85	BTQ	<a href="#">Samples</a>
TPA2006D1DRBTG4	ACTIVE	SON	DRB	8	250	Green (RoHS & no Sb/Br)	CU NIPDAU	Level-2-260C-1 YEAR	-40 to 85	BTQ	<a href="#">Samples</a>

(1) The marketing status values are defined as follows:

**ACTIVE:** Product device recommended for new designs.

**LIFEBUY:** TI has announced that the device will be discontinued, and a lifetime-buy period is in effect.

**NRND:** Not recommended for new designs. Device is in production to support existing customers, but TI does not recommend using this part in a new design.

**PREVIEW:** Device has been announced but is not in production. Samples may or may not be available.

**OBSELETE:** TI has discontinued the production of the device.

(2) Eco Plan - The planned eco-friendly classification: Pb-Free (RoHS), Pb-Free (RoHS Exempt), or Green (RoHS & no Sb/Br) - please check <http://www.ti.com/productcontent> for the latest availability information and additional product content details.

**TBD:** The Pb-Free/Green conversion plan has not been defined.

**Pb-Free (RoHS):** TI's terms "Lead-Free" or "Pb-Free" mean semiconductor products that are compatible with the current RoHS requirements for all 6 substances, including the requirement that lead not exceed 0.1% by weight in homogeneous materials. Where designed to be soldered at high temperatures, TI Pb-Free products are suitable for use in specified lead-free processes.

**Pb-Free (RoHS Exempt):** This component has a RoHS exemption for either 1) lead-based flip-chip solder bumps used between the die and package, or 2) lead-based die adhesive used between the die and leadframe. The component is otherwise considered Pb-Free (RoHS compatible) as defined above.

**Green (RoHS & no Sb/Br):** TI defines "Green" to mean Pb-Free (RoHS compatible), and free of Bromine (Br) and Antimony (Sb) based flame retardants (Br or Sb do not exceed 0.1% by weight in homogeneous material)

(3) MSL, Peak Temp. - The Moisture Sensitivity Level rating according to the JEDEC industry standard classifications, and peak solder temperature.

(4) There may be additional marking, which relates to the logo, the lot trace code information, or the environmental category on the device.

(5) Multiple Device Markings will be inside parentheses. Only one Device Marking contained in parentheses and separated by a "~" will appear on a device. If a line is indented then it is a continuation of the previous line and the two combined represent the entire Device Marking for that device.

(6) Lead/Ball Finish - Orderable Devices may have multiple material finish options. Finish options are separated by a vertical ruled line. Lead/Ball Finish values may wrap to two lines if the finish value exceeds the maximum column width.

**Important Information and Disclaimer:** The information provided on this page represents TI's knowledge and belief as of the date that it is provided. TI bases its knowledge and belief on information provided by third parties, and makes no representation or warranty as to the accuracy of such information. Efforts are underway to better integrate information from third parties. TI has taken and continues to take reasonable steps to provide representative and accurate information but may not have conducted destructive testing or chemical analysis on incoming materials and chemicals. TI and TI suppliers consider certain information to be proprietary, and thus CAS numbers and other limited information may not be available for release.

In no event shall TI's liability arising out of such information exceed the total purchase price of the TI part(s) at issue in this document sold by TI to Customer on an annual basis.

## TAPE AND REEL INFORMATION



### QUADRANT ASSIGNMENTS FOR PIN 1 ORIENTATION IN TAPE



\*All dimensions are nominal

Device	Package Type	Package Drawing	Pins	SPQ	Reel Diameter (mm)	Reel Width W1 (mm)	A0 (mm)	B0 (mm)	K0 (mm)	P1 (mm)	W (mm)	Pin1 Quadrant
TPA2006D1DRBR	SON	DRB	8	3000	330.0	12.4	3.3	3.3	1.1	8.0	12.0	Q2
TPA2006D1DRBT	SON	DRB	8	250	180.0	12.4	3.3	3.3	1.1	8.0	12.0	Q2

**TAPE AND REEL BOX DIMENSIONS**

\*All dimensions are nominal

Device	Package Type	Package Drawing	Pins	SPQ	Length (mm)	Width (mm)	Height (mm)
TPA2006D1DRBR	SON	DRB	8	3000	367.0	367.0	35.0
TPA2006D1DRBT	SON	DRB	8	250	210.0	185.0	35.0

**DRB 8**

**GENERIC PACKAGE VIEW**

**VSON - 1 mm max height**

PLASTIC SMALL OUTLINE - NO LEAD



Images above are just a representation of the package family, actual package may vary.  
Refer to the product data sheet for package details.

4203482/L

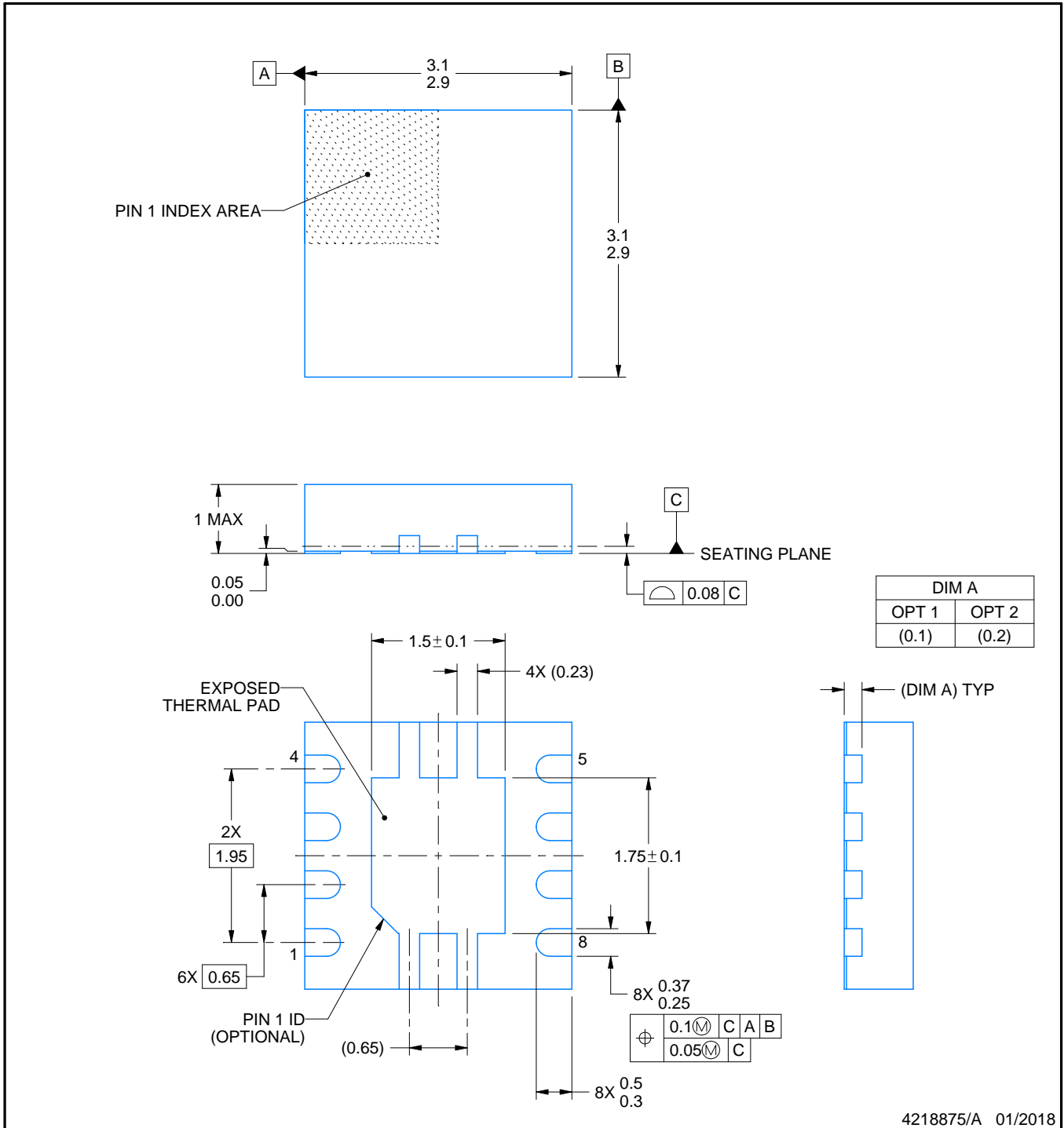

4218875/A 01/2018

NOTES:

1. All linear dimensions are in millimeters. Any dimensions in parenthesis are for reference only. Dimensioning and tolerancing per ASME Y14.5M.
2. This drawing is subject to change without notice.
3. The package thermal pad must be soldered to the printed circuit board for thermal and mechanical performance.

# EXAMPLE BOARD LAYOUT

DRB0008A

VSON - 1 mm max height

PLASTIC SMALL OUTLINE - NO LEAD

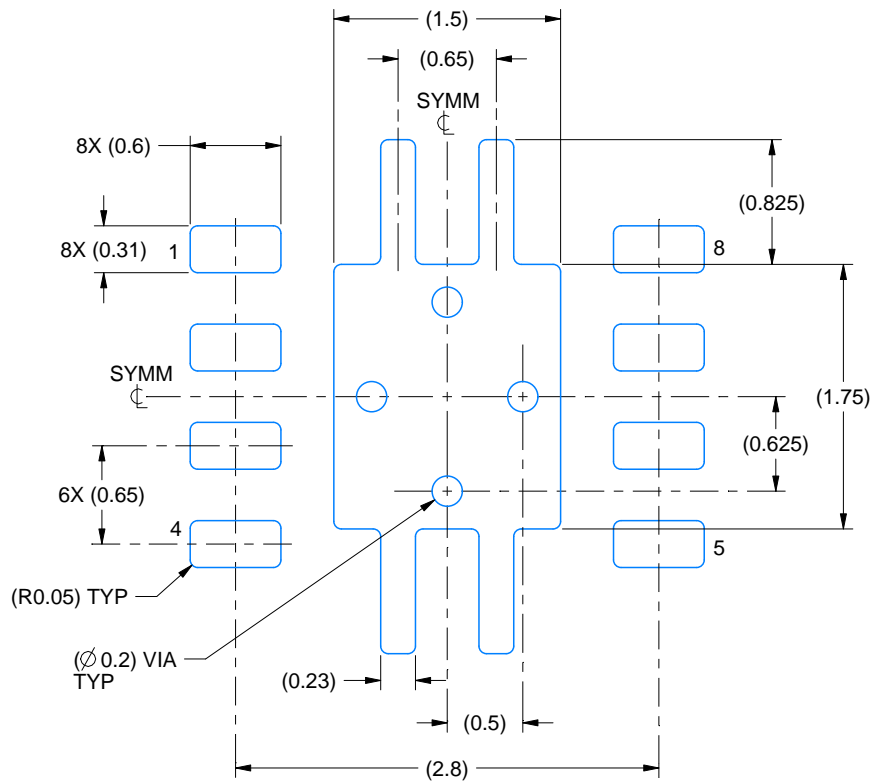

LAND PATTERN EXAMPLE  
EXPOSED METAL SHOWN  
SCALE:20X

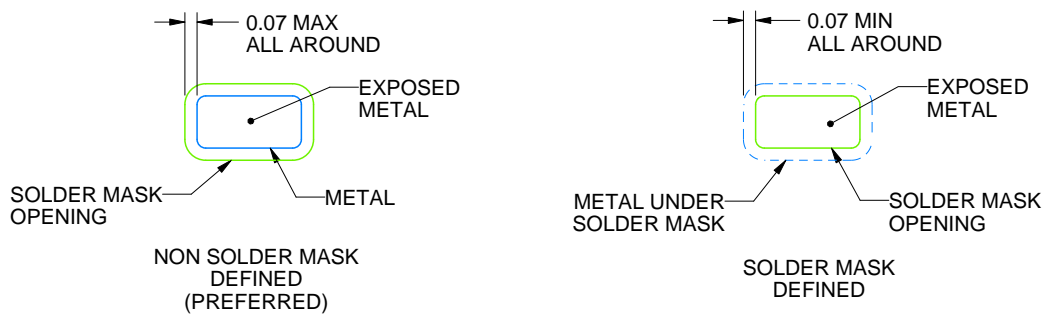

SOLDER MASK DETAILS

4218875/A 01/2018

NOTES: (continued)

4. This package is designed to be soldered to a thermal pad on the board. For more information, see Texas Instruments literature number SLUA271 ([www.ti.com/lit/slua271](http://www.ti.com/lit/slua271)).
5. Vias are optional depending on application, refer to device data sheet. If any vias are implemented, refer to their locations shown on this view. It is recommended that vias under paste be filled, plugged or tented.

# EXAMPLE STENCIL DESIGN

DRB0008A

VSON - 1 mm max height

PLASTIC SMALL OUTLINE - NO LEAD



SOLDER PASTE EXAMPLE  
BASED ON 0.125 mm THICK STENCIL

EXPOSED PAD  
84% PRINTED SOLDER COVERAGE BY AREA  
SCALE:25X

4218875/A 01/2018

NOTES: (continued)

6. Laser cutting apertures with trapezoidal walls and rounded corners may offer better paste release. IPC-7525 may have alternate design recommendations.

## IMPORTANT NOTICE

Texas Instruments Incorporated (TI) reserves the right to make corrections, enhancements, improvements and other changes to its semiconductor products and services per JESD46, latest issue, and to discontinue any product or service per JESD48, latest issue. Buyers should obtain the latest relevant information before placing orders and should verify that such information is current and complete.

TI's published terms of sale for semiconductor products (<http://www.ti.com/sc/docs/stdterms.htm>) apply to the sale of packaged integrated circuit products that TI has qualified and released to market. Additional terms may apply to the use or sale of other types of TI products and services.

Reproduction of significant portions of TI information in TI data sheets is permissible only if reproduction is without alteration and is accompanied by all associated warranties, conditions, limitations, and notices. TI is not responsible or liable for such reproduced documentation. Information of third parties may be subject to additional restrictions. Resale of TI products or services with statements different from or beyond the parameters stated by TI for that product or service voids all express and any implied warranties for the associated TI product or service and is an unfair and deceptive business practice. TI is not responsible or liable for any such statements.

Buyers and others who are developing systems that incorporate TI products (collectively, "Designers") understand and agree that Designers remain responsible for using their independent analysis, evaluation and judgment in designing their applications and that Designers have full and exclusive responsibility to assure the safety of Designers' applications and compliance of their applications (and of all TI products used in or for Designers' applications) with all applicable regulations, laws and other applicable requirements. Designer represents that, with respect to their applications, Designer has all the necessary expertise to create and implement safeguards that (1) anticipate dangerous consequences of failures, (2) monitor failures and their consequences, and (3) lessen the likelihood of failures that might cause harm and take appropriate actions. Designer agrees that prior to using or distributing any applications that include TI products, Designer will thoroughly test such applications and the functionality of such TI products as used in such applications.

TI's provision of technical, application or other design advice, quality characterization, reliability data or other services or information, including, but not limited to, reference designs and materials relating to evaluation modules, (collectively, "TI Resources") are intended to assist designers who are developing applications that incorporate TI products; by downloading, accessing or using TI Resources in any way, Designer (individually or, if Designer is acting on behalf of a company, Designer's company) agrees to use any particular TI Resource solely for this purpose and subject to the terms of this Notice.

TI's provision of TI Resources does not expand or otherwise alter TI's applicable published warranties or warranty disclaimers for TI products, and no additional obligations or liabilities arise from TI providing such TI Resources. TI reserves the right to make corrections, enhancements, improvements and other changes to its TI Resources. TI has not conducted any testing other than that specifically described in the published documentation for a particular TI Resource.

Designer is authorized to use, copy and modify any individual TI Resource only in connection with the development of applications that include the TI product(s) identified in such TI Resource. NO OTHER LICENSE, EXPRESS OR IMPLIED, BY ESTOPPEL OR OTHERWISE TO ANY OTHER TI INTELLECTUAL PROPERTY RIGHT, AND NO LICENSE TO ANY TECHNOLOGY OR INTELLECTUAL PROPERTY RIGHT OF TI OR ANY THIRD PARTY IS GRANTED HEREIN, including but not limited to any patent right, copyright, mask work right, or other intellectual property right relating to any combination, machine, or process in which TI products or services are used. Information regarding or referencing third-party products or services does not constitute a license to use such products or services, or a warranty or endorsement thereof. Use of TI Resources may require a license from a third party under the patents or other intellectual property of the third party, or a license from TI under the patents or other intellectual property of TI.

TI RESOURCES ARE PROVIDED "AS IS" AND WITH ALL FAULTS. TI DISCLAIMS ALL OTHER WARRANTIES OR REPRESENTATIONS, EXPRESS OR IMPLIED, REGARDING RESOURCES OR USE THEREOF, INCLUDING BUT NOT LIMITED TO ACCURACY OR COMPLETENESS, TITLE, ANY EPIDEMIC FAILURE WARRANTY AND ANY IMPLIED WARRANTIES OF MERCHANTABILITY, FITNESS FOR A PARTICULAR PURPOSE, AND NON-INFRINGEMENT OF ANY THIRD PARTY INTELLECTUAL PROPERTY RIGHTS. TI SHALL NOT BE LIABLE FOR AND SHALL NOT DEFEND OR INDEMNIFY DESIGNER AGAINST ANY CLAIM, INCLUDING BUT NOT LIMITED TO ANY INFRINGEMENT CLAIM THAT RELATES TO OR IS BASED ON ANY COMBINATION OF PRODUCTS EVEN IF DESCRIBED IN TI RESOURCES OR OTHERWISE. IN NO EVENT SHALL TI BE LIABLE FOR ANY ACTUAL, DIRECT, SPECIAL, COLLATERAL, INDIRECT, PUNITIVE, INCIDENTAL, CONSEQUENTIAL OR EXEMPLARY DAMAGES IN CONNECTION WITH OR ARISING OUT OF TI RESOURCES OR USE THEREOF, AND REGARDLESS OF WHETHER TI HAS BEEN ADVISED OF THE POSSIBILITY OF SUCH DAMAGES.

Unless TI has explicitly designated an individual product as meeting the requirements of a particular industry standard (e.g., ISO/TS 16949 and ISO 26262), TI is not responsible for any failure to meet such industry standard requirements.

Where TI specifically promotes products as facilitating functional safety or as compliant with industry functional safety standards, such products are intended to help enable customers to design and create their own applications that meet applicable functional safety standards and requirements. Using products in an application does not by itself establish any safety features in the application. Designers must ensure compliance with safety-related requirements and standards applicable to their applications. Designer may not use any TI products in life-critical medical equipment unless authorized officers of the parties have executed a special contract specifically governing such use. Life-critical medical equipment is medical equipment where failure of such equipment would cause serious bodily injury or death (e.g., life support, pacemakers, defibrillators, heart pumps, neurostimulators, and implantables). Such equipment includes, without limitation, all medical devices identified by the U.S. Food and Drug Administration as Class III devices and equivalent classifications outside the U.S.

TI may expressly designate certain products as completing a particular qualification (e.g., Q100, Military Grade, or Enhanced Product). Designers agree that it has the necessary expertise to select the product with the appropriate qualification designation for their applications and that proper product selection is at Designers' own risk. Designers are solely responsible for compliance with all legal and regulatory requirements in connection with such selection.

Designer will fully indemnify TI and its representatives against any damages, costs, losses, and/or liabilities arising out of Designer's non-compliance with the terms and provisions of this Notice.

## Looking for pricing, stock, or lifecycle information?

Click below to explore more details on WIN SOURCE:

 [View TPA2006D1DRBT on WIN SOURCE](#)

 [Texas Instruments](#) Information

## Optimize Your Supply Chain with WIN SOURCE Solutions

-  Global Sourcing Solution
-  Obsolete Management
-  Cost Control Management
-  Shortage Management
-  Alternative Solution
-  Excess Inventory Management