



**THE DATASHEET OF  
SP3220EUEA-L**





# SP3220E/EB/EU

## +3.0V to +5.5V RS-232 Driver/Receiver Pair

### FEATURES

- Meets all EIA/TIA-232-F Standards from a +3.0V to +5.5V power supply
  - Interoperable with RS-232 and V.28 at +2.7V
- Supports High Serial Data Rates:
  - 120kbps SP3220E
  - 250kbps SP3220EB
  - 1Mbps SP3220EU
- 1µA Low Power Shutdown Mode
- Footprint Compatible with MAX3221E, ISL3221
- 4 x 1.0µF External Charge Pump Capacitors
- Improved ESD Specifications:
  - ±15kV Human Body Model
  - ±15kV IEC61000-4-2 Air Discharge
  - ±8kV IEC61000-4-2 Contact Discharge

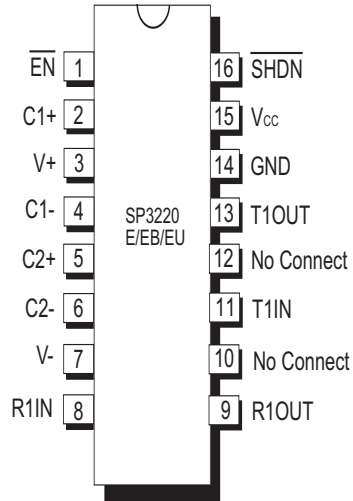

Now Available in Lead Free Packaging

### DESCRIPTION

The **SP3220E** devices are RS-232 driver/receiver solutions intended for portable or hand-held applications such as palmtop computers, instrumentation and consumer products. These devices incorporate a high-efficiency, charge-pump power supply that allows the **SP3220E** devices to deliver true RS-232 performance from a single power supply ranging from +3.0V to +5.0V. This charge pump requires only 0.1µF capacitors in 3.3V operation. The ESD tolerance of these devices are over +/-15kV for both Human Body Model and IEC61000-4-2 Air discharge test methods. All devices have a low-power shutdown mode where the driver outputs and charge pumps are disabled. During shutdown, the supply current falls to less than 1µA.

### SELECTION TABLE

MODEL	Power Supplies	RS-232 Drivers	RS-232 Receivers	External Components	Shutdown	Data Rate
SP3220E	+3.0V to +5.5V	1	1	4 Capacitors	Yes	120kbps
SP3220EB	+3.0V to +5.5V	1	1	4 Capacitors	Yes	250kbps
SP3220EU	+3.0V to +5.5V	1	1	4 Capacitors	Yes	1Mbps

These are stress ratings only and functional operation of the device at these ratings or any other above those indicated in the operation sections of the specifications below is not implied. Exposure to absolute maximum rating conditions for extended periods of time may affect reliability and cause permanent damage to the device.

V <sub>CC</sub> .....	-0.3V to +6.0V
V+ (NOTE 1).....	-0.3V to +7.0V
V- (NOTE 1).....	+0.3V to -7.0V
V+ +  V-  (NOTE 1).....	+13V
I <sub>CC</sub> (DC V <sub>CC</sub> or GND current).....	±100mA

**Power Dissipation per package**

16-pin SSOP (derate 9.69mW/°C above +70°C).....	775mW
16-pin TSSOP (derate 10.5mW/°C above +70°C).....	840mW

**Input Voltages**

TxIN, EN, SHDN.....	-0.3V to V <sub>CC</sub> + 0.3V
RxIN.....	±25V

**Output Voltages**

TxOUT.....	±13.2V
RxOUT, .....	-0.3V to (V <sub>CC</sub> +0.3V)

**Short-Circuit Duration**

TxOUT.....	Continuous
Storage Temperature.....	-65°C to +150°C

**NOTE 1:** V+ and V- can have maximum magnitudes of 7V, but their absolute difference cannot exceed 13V.

## ELECTRICAL CHARACTERISTICS

Unless otherwise noted, the following specifications apply for V<sub>CC</sub> = +3.0V to +5.5V with T<sub>AMB</sub> = T<sub>MIN</sub> to T<sub>MAX</sub>. Typical values apply at V<sub>CC</sub> = +3.3V or +5.0V and T<sub>AMB</sub> = 25°C, C1 - C4 = 0.1µF.

PARAMETER	MIN.	TYP.	MAX.	UNITS	CONDITIONS
<b>DC CHARACTERISTICS</b>					
Supply Current		0.3	1.0	mA	no load, V <sub>CC</sub> = 3.3V, T <sub>AMB</sub> = 25°C, TxIN = GND or V <sub>CC</sub>
Shutdown Supply Current		1.0	10	µA	SHDN = GND, V <sub>CC</sub> = 3.3V, T <sub>AMB</sub> = 25°C, TxIN = V <sub>CC</sub> or GND
<b>LOGIC INPUTS AND RECEIVER OUTPUTS</b>					
Input Logic Threshold LOW	GND		0.8	V	TxIN, EN, SHDN, Note 2
Input Logic Threshold HIGH	2.0			V	V <sub>CC</sub> = 3.3V, Note 2
Input Logic Threshold HIGH	2.4			V	V <sub>CC</sub> = 5.0V, Note 2
Input Leakage Current		±0.01	±1.0	µA	TxIN, EN, SHDN, T <sub>AMB</sub> = +25°C, V <sub>IN</sub> = 0V to V <sub>CC</sub>
Output Leakage Current		±0.05	±10	µA	Receivers disabled, V <sub>OUT</sub> = 0V to V <sub>CC</sub>
Output Voltage LOW			0.4	V	I <sub>OUT</sub> = 1.6mA
Output Voltage HIGH	V <sub>CC</sub> -0.6	V <sub>CC</sub> -0.1		V	I <sub>OUT</sub> = -1.0mA
<b>DRIVER OUTPUTS</b>					
Output Voltage Swing	±5.0	±5.4		V	Driver output loaded with 3KΩ to GND, T <sub>AMB</sub> = +25°C

NOTE 2: Driver input hysteresis is typically 250mV.

## ELECTRICAL CHARACTERISTICS

Unless otherwise noted, the following specifications apply for  $V_{CC} = +3.0V$  to  $+5.5V$  with  $T_{AMB} = T_{MIN}$  to  $T_{MAX}$ .  
 Typical values apply at  $V_{CC} = +3.3V$  or  $+5.0V$  and  $T_{AMB} = 25^{\circ}C$ .

PARAMETER	MIN.	TYP.	MAX.	UNITS	CONDITIONS
<b>DRIVER OUTPUTS (continued)</b>					
Output Resistance	300			$\Omega$	$V_{CC} = V+ = V- = 0V, T_{OUT} = \pm 2V$
Output Short-Circuit Current		$\pm 35$	$\pm 60$	mA	$V_{OUT} = 0V$
Output Leakage Current			$\pm 25$	$\mu A$	$V_{OUT} = \pm 12V, V_{CC} = GND$ to $5.5V$ , Drivers disabled
<b>RECEIVER INPUTS</b>					
Input Voltage Range	-15		+15	V	
Input Threshold LOW	0.6	1.2		V	$V_{CC} = 3.3V$
Input Threshold LOW	0.8	1.5		V	$V_{CC} = 5.0V$
Input Threshold HIGH		1.5	2.4	V	$V_{CC} = 3.3V$
Input Threshold HIGH		1.8	2.4	V	$V_{CC} = 5.0V$
Input Hysteresis		0.3		V	
Input Resistance	3	5	7	k $\Omega$	
<b>TIMING CHARACTERISTICS</b>					
Data Rate SP3220E	120	235		kbps	$R_L = 3K\Omega, C_L = 1000pF$
Data Rate SP3220EB	250			kbps	$R_L = 3K\Omega, C_L = 1000pF$
Data Rate SP3220EU	1000			kbps	$R_L = 3K\Omega, C_L = 250pF$
Receiver Propagation Delay, $t_{PHL}$		0.15		$\mu s$	Receiver input to Receiver output, $C_L = 150pF$
Receiver Propagation Delay, $t_{PLH}$		0.15		$\mu s$	Receiver input to Receiver output, $C_L = 150pF$
Receiver Output Enable Time		200		ns	
Receiver Output Disable Time		200		ns	
Driver Skew		100		ns	$ t_{PHL} - t_{PLH} , T_{AMB} = 25^{\circ}C$
Receiver Skew		50		ns	$ t_{PHL} - t_{PLH} $
Transition-Region Slew Rate			30	V/ $\mu s$	$V_{CC} = 3.3V, R_L = 3k\Omega, T_{AMB} = 25^{\circ}C$ , measurements taken from $-3.0V$ to $+3.0V$ or $+3.0V$ to $-3.0V$ (SP3220E and SP3220EB)
Transition-Region Slew Rate		90		V/ $\mu s$	$V_{CC} = 3.3V, R_L = 3k\Omega, T_{AMB} = 25^{\circ}C$ , measurements taken from $-3.0V$ to $+3.0V$ or $+3.0V$ to $-3.0V$ (SP3220EU)

## TYPICAL PERFORMANCE CHARACTERISTICS

Unless otherwise noted, the following performance characteristics apply for  $V_{CC} = +3.3V$ , 250kbps data rate, all drivers loaded with  $3k\Omega$ ,  $0.1\mu F$  charge pump capacitors, and  $T_{AMB} = +25^{\circ}C$ .

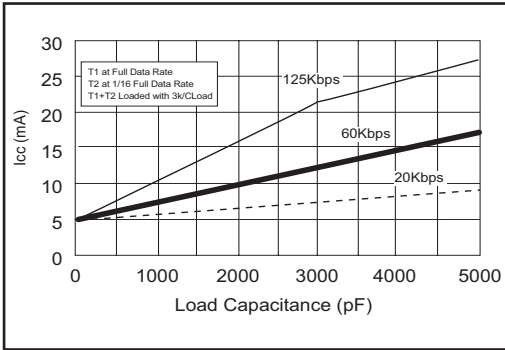

Figure 1.  $I_{cc}$  vs Load Capacitance for the SP3220EB.

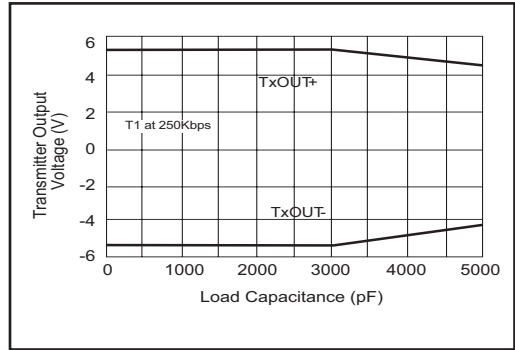

Figure 2. Transmitter Output Voltage vs Load Capacitance for the SP3220EB.

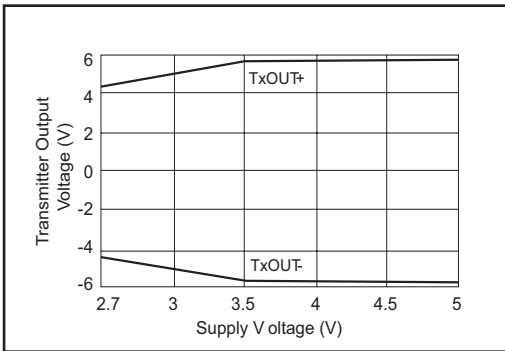

Figure 3. Transmitter Output Voltage vs Supply Voltage for the SP3220EB.

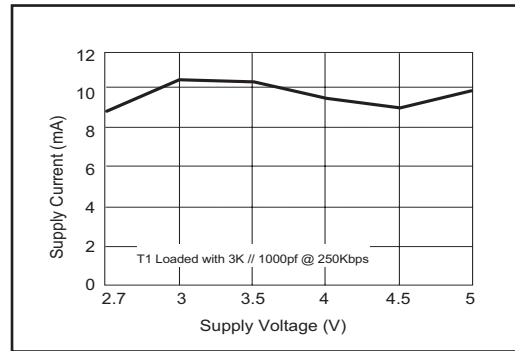

Figure 4. Supply Current vs Supply Voltage for the SP3220EB.

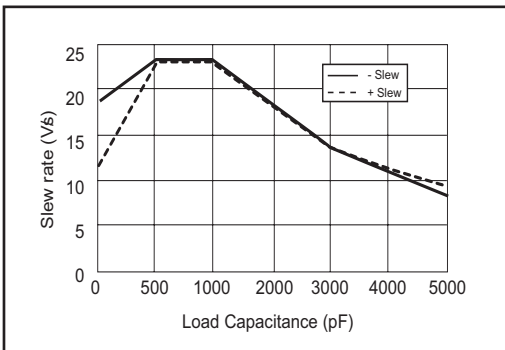

Figure 5. Slew Rate vs Load Capacitance for the SP3220EB.

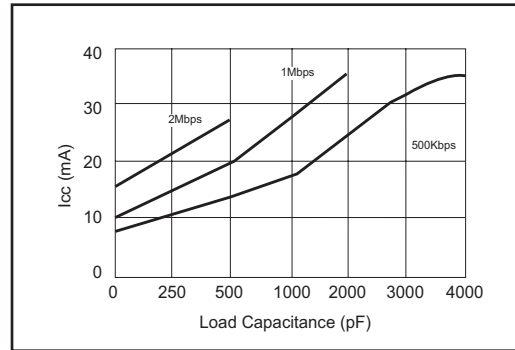

Figure 6. Supply Current vs Supply Voltage for the SP3220EU.

## TYPICAL PERFORMANCE CHARACTERISTICS: Continued

Unless otherwise noted, the following performance characteristics apply for  $V_{CC} = +3.3V$ , 250kbps data rate, all drivers loaded with  $3k\Omega$ ,  $0.1\mu F$  charge pump capacitors, and  $T_{AMB} = +25^{\circ}C$ .

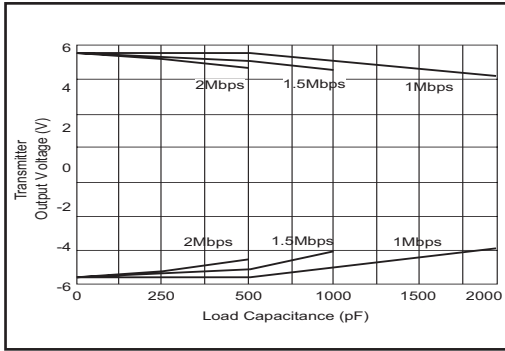

Figure 7. Transmitter Output Voltage vs Load Capacitance for the SP3220EU.

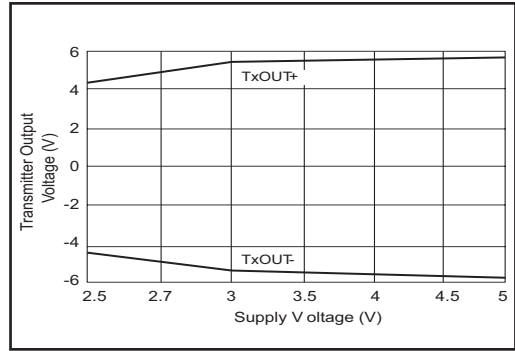

Figure 8. Transmitter Output Voltage vs Supply Voltage for the SP3220EU.

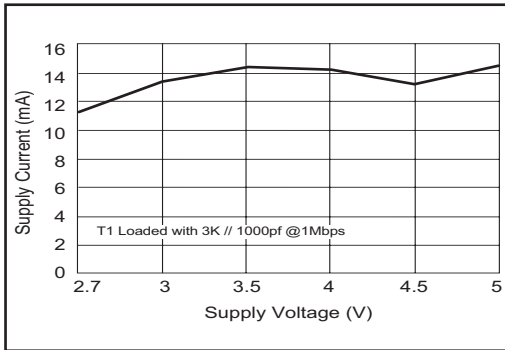

Figure 9. Supply Current vs Supply Voltage for the SP3220EU.

NAME	FUNCTION	PIN NUMBER
$\overline{\text{EN}}$	Receiver Enable. Apply Logic LOW for normal operation. Apply logic HIGH to disable the receiver outputs (high-Z state)	1
C1+	Positive terminal of the voltage doubler charge-pump capacitor	2
V+	+5.5V output generated by the charge pump	3
C1-	Negative terminal of the voltage doubler charge-pump capacitor	4
C2+	Positive terminal of the inverting charge-pump capacitor	5
C2-	Negative terminal of the inverting charge-pump capacitor	6
V-	-5.5V output generated by the charge pump	7
R <sub>1</sub> IN	RS-232 receiver input	8
R <sub>1</sub> OUT	TTL/CMOS receiver output	9
T <sub>1</sub> IN	TTL/CMOS driver input	11
T <sub>1</sub> OUT	RS-232 driver output.	13
GND	Ground	14
V <sub>CC</sub>	+3.0V to +5.5V supply voltage	15
$\overline{\text{SHDN}}$	Shutdown Control Input. Drive HIGH for normal device operation. Drive LOW to shutdown the drivers (high-Z output) and the on-board power supply	16
N.C.	No Connect	10, 12

Table 1. Device Pin Description

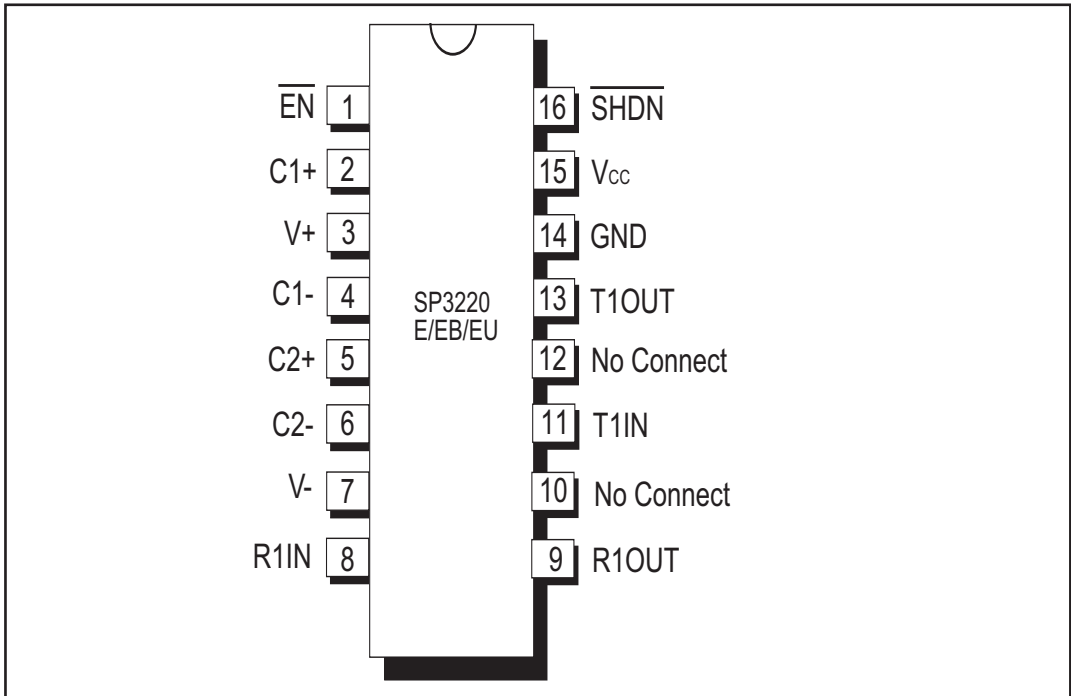

Figure 10. Pinout Configurations for the SP3220E/EB/EU

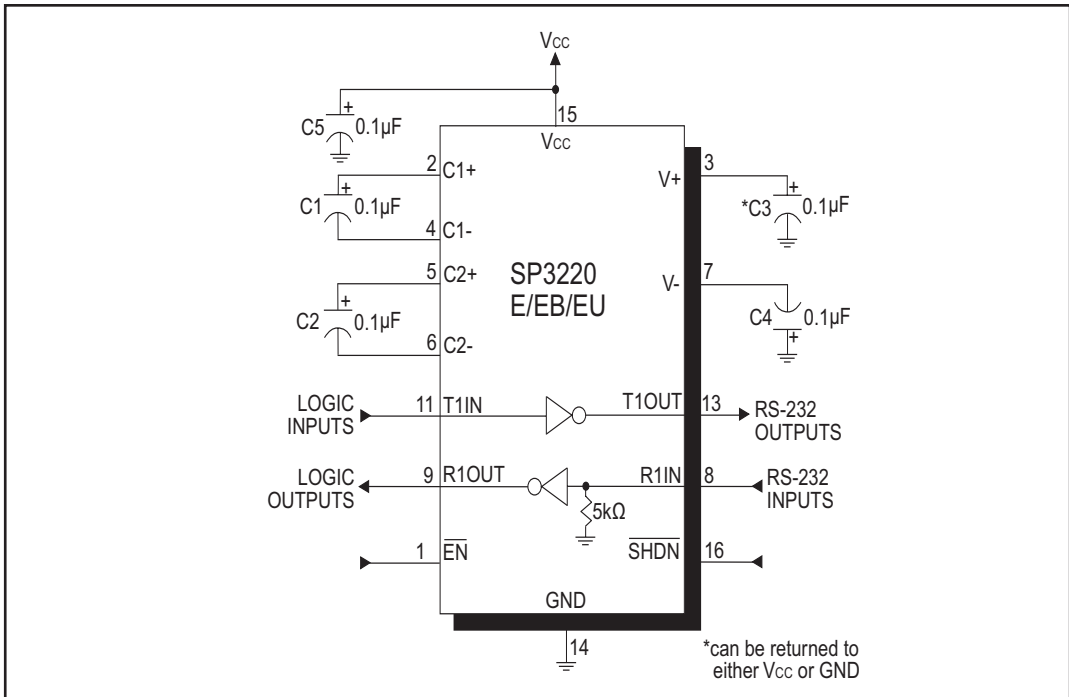

Figure 11. SP3220E/EB/EU Typical Operating Circuit

The **SP3220E/EB/EU** devices meet the EIA/TIA-232 and ITU-T V.28/V.24 communication protocols and can be implemented in battery-powered, portable, or hand-held applications such as notebook or palmtop computers. The **SP3220E/EB/EU** devices feature **Exar's** proprietary on-board charge pump circuitry that generates  $\pm 5.5\text{V}$  for RS-232 voltage levels from a single  $+3.0\text{V}$  to  $+5.5\text{V}$  power supply. This series is ideal for  $+3.3\text{V}$ -only systems, mixed  $+3.3\text{V}$  to  $+5.5\text{V}$  systems, or  $+5.0\text{V}$ -only systems that require true RS-232 performance. The **SP3220EB** device has a driver that can operate at a data rate of 250kbps fully loaded. The **SP3220EU** can operate at 1000kbps; the **SP3220E** device can operate at a typical data rate of 235kbps when fully loaded.

The **SP3220E/EB/EU** is a 1-driver/1-receiver device ideal for portable or hand-held applications. The **SP3220E/EB/EU** features a  $1\mu\text{A}$  shutdown mode that reduces power consumption and extends battery life in portable systems. Its receivers remain active in shutdown mode, allowing external devices such as modems to be monitored using only  $1\mu\text{A}$  supply current.

## THEORY OF OPERATION

The **SP3220E/EB/EU** series is made up of three basic circuit blocks:

1. Driver
2. Receiver
3. The Exar proprietary charge pump

### Driver

The driver is an inverting level transmitter that converts TTL or CMOS logic levels to  $\pm 5.0\text{V}$  EIA/TIA-232 levels with an inverted sense relative to the input logic levels. Typically, the RS-232 output voltage swing is  $\pm 5.5\text{V}$  with no load and at least  $\pm 5\text{V}$  minimum fully loaded. The driver outputs are protected against infinite short-circuits to ground without degradation in reliability. Driver outputs

will meet EIA/TIA-562 levels of  $\pm 3.7\text{V}$  with supply voltages as low as  $2.7\text{V}$ .

The **SP3220EB** driver can guarantee a data rate of 250kbps fully loaded with  $3\text{k}\Omega$  in parallel with  $1000\text{pF}$ , ensuring compatibility with PC-to-PC communication software. The **SP3220EU** driver can guarantee a data rate of 1000kbps fully loaded with  $3\text{k}\Omega$  in parallel with  $250\text{pF}$ .

The slew rate of the **SP3220E** and **SP3220EB** outputs are internally limited to a maximum of  $30\text{V}/\mu\text{s}$  in order to meet the EIA standards (EIA RS-232D 2.1.7, Paragraph 5). The transition of the loaded output from HIGH to LOW also meet the monotonicity requirements of the standard. The slew rate of the **SP3220EU** is not limited. This allows it to transmit at much faster data rates.

Figure 12 shows a loopback test circuit used to test the RS-232 Driver. Figure 13 shows the test results of the loopback circuit with the **SP3220EB** driver active at 250kbps with RS-232 load in parallel with a  $1000\text{pF}$  capacitor. Figure 14 shows the test results where the **SP3220EU** driver was active at 1000kbps and loaded with an RS-232 receiver in parallel with  $250\text{pF}$  capacitors. A solid RS-232 data transmission rate of 250kbps provides compatibility with many designs in personal computer peripherals and LAN applications.

The **SP3220E/EB/EU** driver's output stage is turned off (tri-state) when the device is in shutdown mode. When the power is off, the **SP3220E/EB/EU** device permits the outputs to be driven up to  $\pm 12\text{V}$ . The driver's inputs do not have pull-up resistors. Designers should connect unused inputs to  $V_{cc}$  or GND.

In the shutdown mode, the supply current falls to less than  $1\mu\text{A}$ , where  $\text{SHDN} = \text{LOW}$ . When the **SP3220E/EB/EU** device is shut down, the device's driver output is disabled

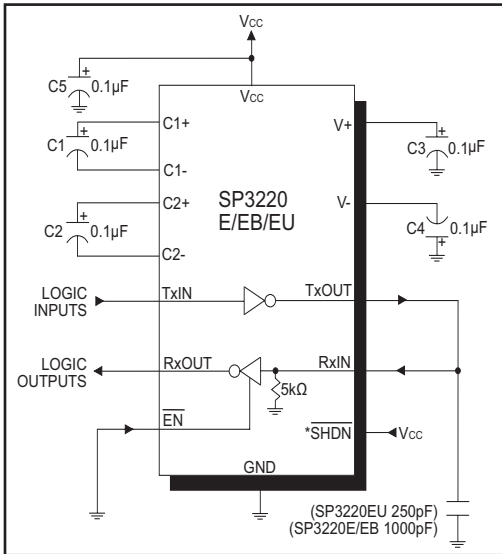

Figure 12. SP3220E/EB/EU Driver Loopback Test Circuit

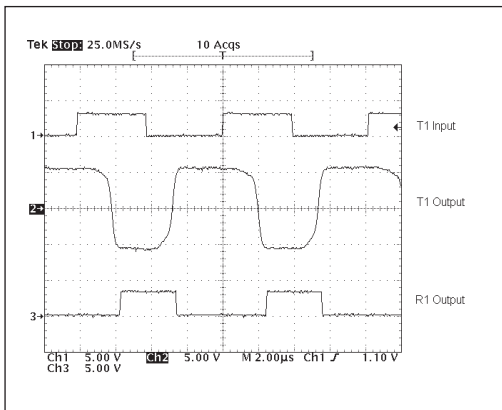

Figure 13. SP3220EB Loopback Test results at 250kbps

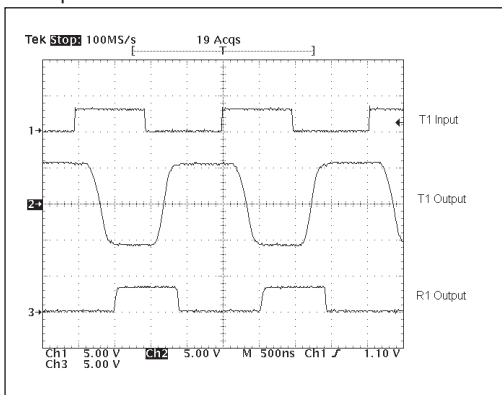

Figure 14. SP3220EU Loopback Test results at 1Mbps

(tri-stated) and the charge pump is turned off with V+ pulled down to Vcc and V- pulled to GND. The time required to exit shutdown is typically 100ms. Connect SHDN to Vcc if the shutdown mode is not used. SHDN has no effect on RxOUT. Note that the driver is enabled only when the magnitude of V- exceeds approximately 3V.

**Receiver**

The receiver converts EIA/TIA-232 levels to TTL or CMOS logic output levels. The receiver has an inverting high-impedance output. This receiver output (RxOUT) is at high-impedance when the enable control EN = HIGH. In the shutdown mode, the receiver can be active or inactive. EN has no effect on TxOUT. The truth table logic of the **SP3220E/EB/EU** driver and receiver outputs can be found in Table 2.

SHDN	EN	TxOUT	RxOUT
0	0	Tri-state	Active
0	1	Tri-state	Tri-state
1	0	Active	Active
1	1	Active	Tri-state

Table 2. SP3220E/EB/EU Truth Table Logic for Shutdown and Enable Control

Since receiver input is usually from a transmission line where long cable lengths and system interference can degrade the signal, the inputs have a typical hysteresis margin of 300mV. This ensures that the receiver is virtually immune to noisy transmission lines. Should an input be left unconnected, an internal 5KΩ pull-down resistor to ground will commit the output of the receiver to a HIGH state.

## Charge Pump

The charge pump is an Exar-patented design (U.S. 5,306,954) and uses a unique approach compared to older less-efficient designs. The charge pump still requires four external capacitors, but uses a four-phase voltage shifting technique to attain symmetrical 5.5V power supplies. The internal power supply consists of a regulated dual charge pump that provides output voltages of +/-5.5V regardless of the input voltage ( $V_{CC}$ ) over the +3.0V to +5.5V range.

In most circumstances, decoupling the power supply can be achieved adequately using a 0.1 $\mu$ F bypass capacitor at C5 (refer to figures 6 and 7). In applications that are sensitive to power-supply noise, decouple  $V_{CC}$  to ground with a capacitor of the same value as charge-pump capacitor C1. Physically connect bypass capacitor as close to the IC as possible.

The charge pump operates in a discontinuous mode using an internal oscillator. If the output voltages are less than a magnitude of 5.5V, the charge pump is enabled. If the output voltages exceed a magnitude of 5.5V, the charge pump is disabled. This oscillator controls the four phases of the voltage shifting. A description of each phase follows.

### Phase 1

—  $V_{SS}$  charge storage — During this phase of the clock cycle, the positive side of capacitors  $C_1$  and  $C_2$  are initially charged to  $V_{CC}$ .  $C_1^+$  is then switched to GND and the charge in  $C_1^-$  is transferred to  $C_2^-$ . Since  $C_2^+$  is connected to  $V_{CC}$ , the voltage potential across capacitor  $C_2$  is now 2 times  $V_{CC}$ .

### Phase 2

—  $V_{SS}$  transfer — Phase two of the clock connects the negative terminal of  $C_2$  to the  $V_{SS}$  storage capacitor and the positive terminal of  $C_2$  to GND. This transfers a negative generated voltage to  $C_3$ . This generated voltage is regulated to a minimum voltage of -5.5V.

Simultaneous with the transfer of the voltage to  $C_3$ , the positive side of capacitor  $C_1$  is switched to  $V_{CC}$  and the negative side is connected to GND.

### Phase 3

—  $V_{DD}$  charge storage — The third phase of the clock is identical to the first phase — the charge transferred in  $C_1$  produces  $-V_{CC}$  in the negative terminal of  $C_1$ , which is applied to the negative side of capacitor  $C_2$ . Since  $C_2^+$  is at  $V_{CC}$ , the voltage potential across  $C_2$  is 2 times  $V_{CC}$ .

### Phase 4

—  $V_{DD}$  transfer — The fourth phase of the clock connects the negative terminal of  $C_2$  to GND, and transfers this positive generated voltage across  $C_2$  to  $C_4$ , the  $V_{DD}$  storage capacitor. This voltage is regulated to +5.5V. At this voltage, the internal oscillator is disabled. Simultaneous with the transfer of the voltage to  $C_4$ , the positive side of capacitor  $C_1$  is switched to  $V_{CC}$  and the negative side is connected to GND, allowing the charge pump cycle to begin again. The charge pump cycle will continue as long as the operational conditions for the internal oscillator are present.

Since both  $V^+$  and  $V^-$  are separately generated from  $V_{CC}$ , in a no-load condition  $V^+$  and  $V^-$  will be symmetrical. Older charge pump approaches that generate  $V^-$  from  $V^+$  will show a decrease in the magnitude of  $V^-$  compared to  $V^+$  due to the inherent inefficiencies in the design.

## Charge Pump Design Guidelines

The charge pump operates with 0.1 $\mu$ F capacitors for 3.3V operation. For other supply voltages, see the table for required capacitor values. Do not use values smaller than those listed. Increasing the capacitor values (e.g., by doubling in value) reduces ripple on the transmitter outputs and may slightly reduce power consumption. C2, C3, and C4 may be increased without changing C1's value.

Minimum recommended charge pump capacitor value	
Input Voltage Vcc	Charge pump capacitor value for SP3220E/EB/EU
3.0V to 3.6V	C1 - C4 = 0.1 $\mu$ F
3.0V to 5.5V	C1 - C4 = 0.22 $\mu$ F

The charge pump oscillator typically operates at greater than 250kHz allowing the pump to run efficiently with small 0.1 $\mu$ F capacitors. Efficient operation depends on rapidly charging and discharging C1 and C2, therefore capacitors should be mounted close to the IC and have low ESR (equivalent series resistance).

Low cost surface mount ceramic capacitors (such as are widely used for power-supply decoupling) are ideal for use on the charge pump. However the charge pumps are designed to be able to function properly with a wide range of capacitor styles and values. If polarized capacitors are used the positive and negative terminals should be connected as shown in the Typical Operating Circuit.

Voltage potential across any of the capacitors will never exceed 2 x VCC. Therefore capacitors with working voltages as low as 6.3V rating may be used with a 3.0V VCC supply. The reference terminal of the V+ capacitor may be connected either to VCC or ground, but if connected to ground a minimum 10V working voltage is required. Higher working voltages and/or capacitance values may be advised if operating at higher VCC or to provide greater stability as the capacitors age.

Under lightly loaded conditions the intelligent pump oscillator maximizes efficiency by running only as needed to maintain V+ and V-. Since interface transceivers often spend much of their time at idle this power-efficient innovation can greatly reduce total power consumption. This improvement is made possible by the independent phase sequence of the Exar charge-pump design.

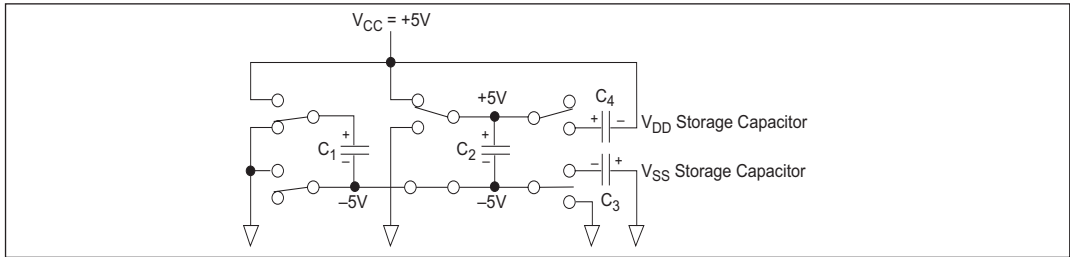

Figure 15. Charge Pump — Phase 1

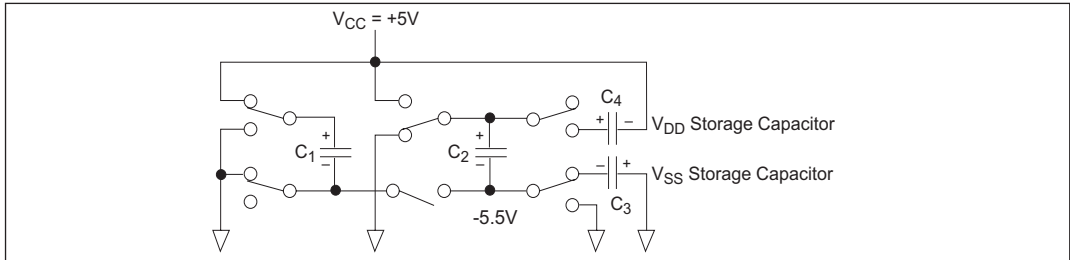

Figure 16. Charge Pump — Phase 2

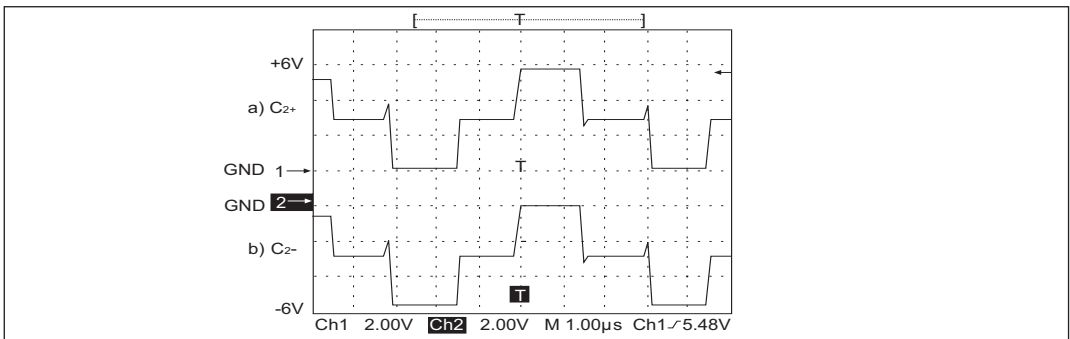

Figure 17. Charge Pump Waveforms

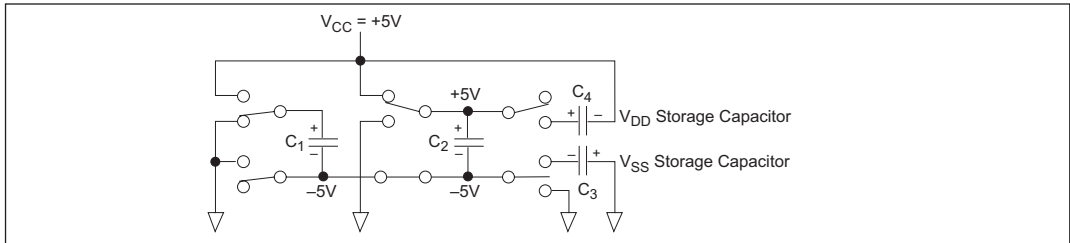

Figure 18. Charge Pump — Phase 3

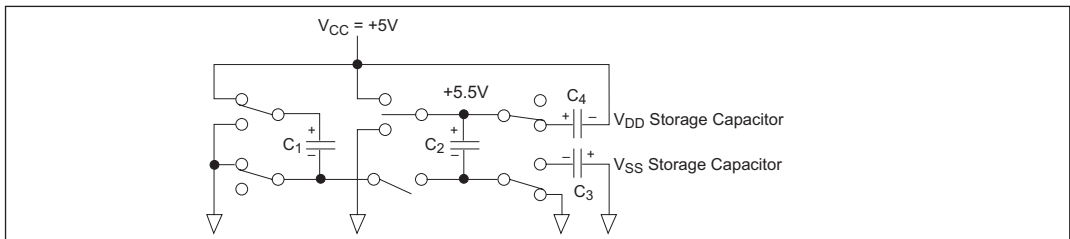

Figure 19. Charge Pump — Phase 4

## ESD TOLERANCE

The **SP3220E/EB/EU** device incorporates ruggedized ESD cells on all driver output and receiver input pins. The ESD structure is improved over our previous family for more rugged applications and environments sensitive to electro-static discharges and associated transients. The improved ESD tolerance is at least  $\pm 15\text{kV}$  without damage nor latch-up.

There are different methods of ESD testing applied:

- a) MIL-STD-883, Method 3015.7
- b) IEC61000-4-2 Air-Discharge
- c) IEC61000-4-2 Direct Contact

The Human Body Model has been the generally accepted ESD testing method for semi-conductors. This method is also specified in MIL-STD-883, Method 3015.7 for ESD testing. The premise of this ESD test is to simulate the human body's potential to store electro-static energy and discharge it to an integrated circuit. The simulation is performed by using a test model as shown in Figure 20. This method will test the IC's capability to withstand an ESD transient during normal handling such as in manufacturing areas where the IC's tend to be handled frequently.

The IEC-61000-4-2, formerly IEC801-2, is generally used for testing ESD on equipment and systems. For system manufacturers, they must guarantee a certain amount of ESD protection since the system itself is exposed to the outside environment and human presence. The premise with IEC61000-4-2 is that

the system is required to withstand an amount of static electricity when ESD is applied to points and surfaces of the equipment that are accessible to personnel during normal usage. The transceiver IC receives most of the ESD current when the ESD source is applied to the connector pins. The test circuit for IEC61000-4-2 is shown on Figure 21. There are two methods within IEC61000-4-2, the Air Discharge method and the Contact Discharge method.

With the Air Discharge Method, an ESD voltage is applied to the equipment under test (EUT) through air. This simulates an electrically charged person ready to connect a cable onto the rear of the system only to find an unpleasant zap just before the person touches the back panel. The high energy potential on the person discharges through an arcing path to the rear panel of the system before he or she even touches the system. This energy, whether discharged directly or through air, is predominantly a function of the discharge current rather than the discharge voltage. Variables with an air discharge such as approach speed of the object carrying the ESD potential to the system and humidity will tend to change the discharge current. For example, the rise time of the discharge current varies with the approach speed.

The Contact Discharge Method applies the ESD current directly to the EUT. This method was devised to reduce the unpredictability of the ESD arc. The discharge current rise time is constant since the energy is directly transferred without the air-gap arc. In situations such as hand held systems, the ESD charge can be directly discharged to the

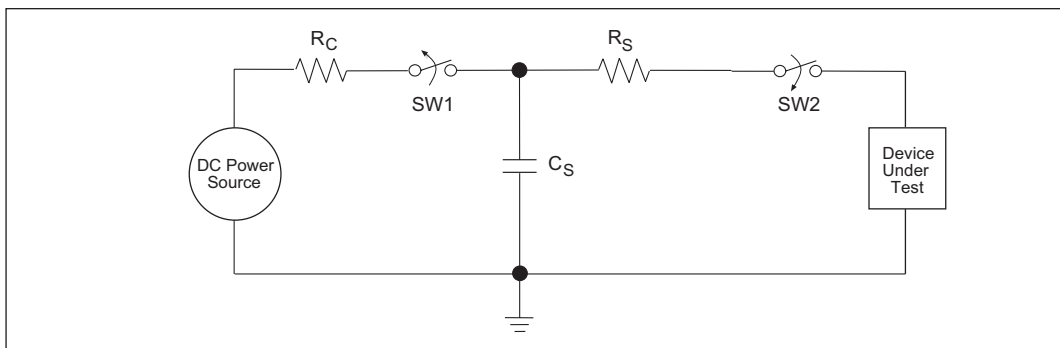

Figure 20. ESD Test Circuit for Human Body Model

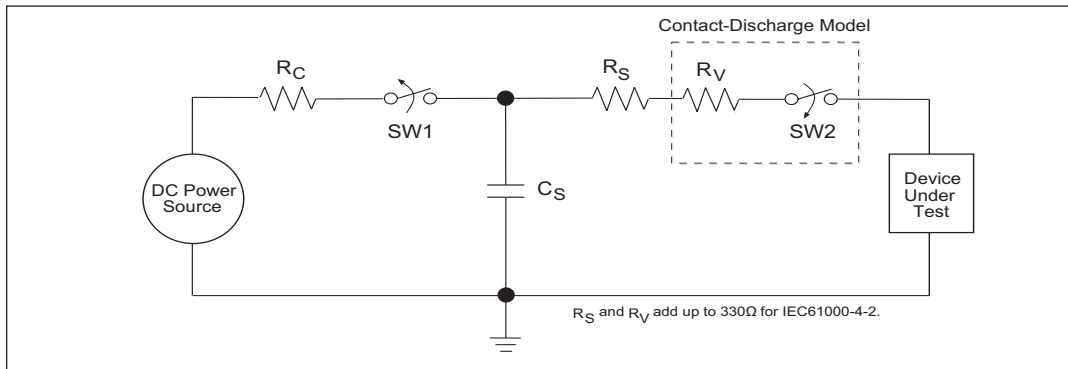

Figure 21. ESD Test Circuit for IEC61000-4-2

equipment from a person already holding the equipment. The current is transferred on to the keypad or the serial port of the equipment directly and then travels through the PCB and finally to the IC.

The circuit models in Figures 20 and 21 represent the typical ESD testing circuit used for all three methods. The  $C_s$  is initially charged with the DC power supply when the first switch (SW1) is on. Now that the capacitor is charged, the second switch (SW2) is on while SW1 switches off. The voltage stored in the capacitor is then applied through  $R_s$ , the current limiting resistor, onto the device under test (DUT). In ESD tests, the SW2 switch is pulsed so that the device under test receives a duration of voltage.

For the Human Body Model, the current limiting resistor ( $R_s$ ) and the source capacitor ( $C_s$ ) are  $1.5k\Omega$  and  $100pF$ , respectively. For IEC-61000-4-2, the current limiting resistor ( $R_s$ ) and the source capacitor ( $C_s$ ) are  $330\Omega$  and  $150pF$ , respectively.

The higher  $C_s$  value and lower  $R_s$  value in the IEC61000-4-2 model are more stringent than the Human Body Model. The larger storage capacitor injects a higher voltage to the test point when SW2 is switched on. The lower current limiting resistor increases the current charge onto the test point.

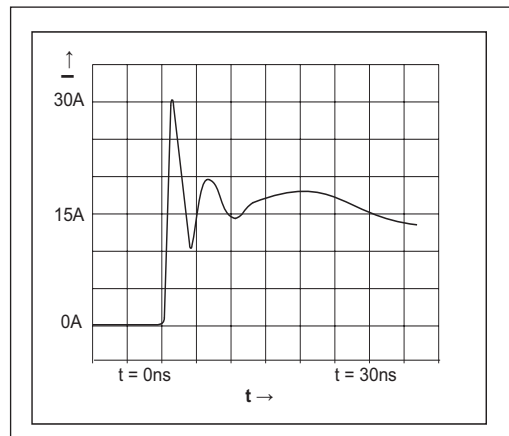
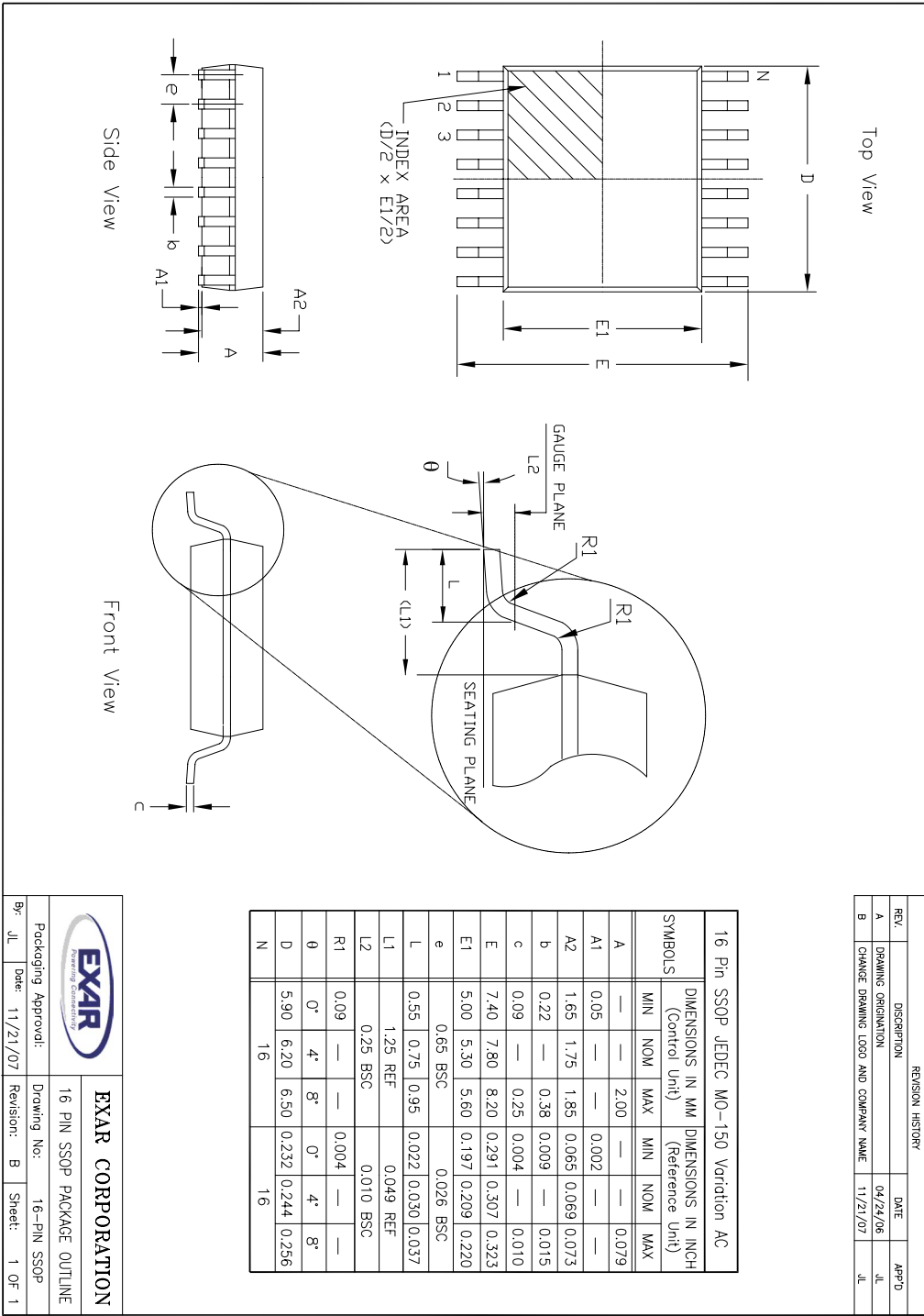

Figure 22. ESD Test Waveform for IEC61000-4-2

DEVICE PIN TESTED	HUMAN BODY MODEL	IEC61000-4-2		
		Air Discharge	Direct Contact	Level
Driver Outputs	$\pm 15kV$	$\pm 15kV$	$+8kV$	4
Receiver Inputs	$\pm 15kV$	$\pm 15kV$	$\pm 8kV$	4

Table 3. Transceiver ESD Tolerance Levels



REVISION HISTORY			
REV.	DESCRIPTION	DATE	APP'D
A	DRAWING ORIENTATION	04/24/06	JL
B	CHANGE DRAWING LOGO AND COMPANY NAME	11/21/07	JL

16 Pin SSOP JEDEC MO-150 Variation AC						
SYMBOLS	DIMENSIONS IN MM (Control Unit)			DIMENSIONS IN INCH (Reference Unit)		
	MIN	NOM	MAX	MIN	NOM	MAX
A	—	—	2.00	—	—	0.079
A1	0.05	—	—	0.002	—	—
A2	1.65	1.75	1.85	0.065	0.069	0.073
b	0.22	—	0.38	0.009	—	0.015
c	0.09	—	0.25	0.004	—	0.010
E	7.40	7.80	8.20	0.291	0.307	0.323
E1	5.00	5.30	5.60	0.197	0.209	0.220
e	0.65 BSC			0.026 BSC		
L	0.55	0.75	0.95	0.022	0.030	0.037
L1	1.25 REF			0.049 REF		
L2	0.25 BSC			0.010 BSC		
R1	0.09	—	—	0.004	—	—
θ	0°	4°	8°	0°	4°	8°
D	5.90	6.20	6.50	0.232	0.244	0.256
N	16			16		

		<b>EXAR CORPORATION</b>	
Packaging Approval:		Drawing No:	
Bf: JL		16 PIN SSOP PACKAGE OUTLINE	
Date: 11/21/07		Revision: B	
		Sheet: 1 OF 1	

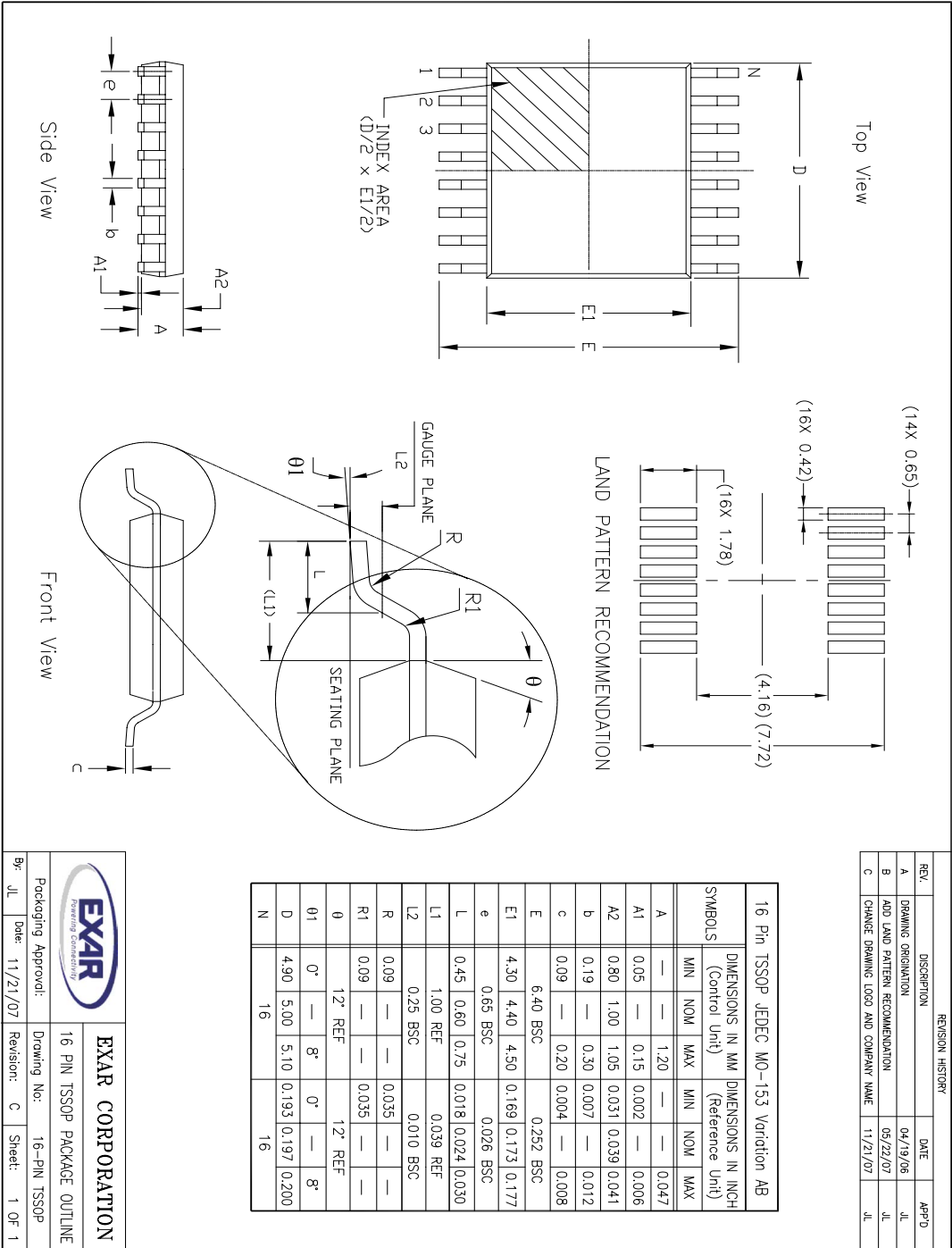

REVISION HISTORY			
REV.	DESCRIPTION	DATE	APP'D
A	DRAWING ORIGINATOR	04/19/06	JL
B	ADD LAND PATTERN RECOMMENDATION	05/22/07	JL
C	CHANGE DRAWING LOGO AND COMPANY NAME	11/21/07	JL

16 Pin TSSOP JEDEC MO-153 Variation AB						
SYMBOLS	DIMENSIONS IN MM (Control Unit)			DIMENSIONS IN INCH (Reference Unit)		
	MIN	NOM	MAX	MIN	NOM	MAX
A	—	1.20	—	—	—	0.047
A1	0.05	—	0.15	0.002	—	0.006
A2	0.80	1.00	1.05	0.031	0.039	0.041
b	0.19	—	0.30	0.007	—	0.012
c	0.09	—	0.20	0.004	—	0.008
E	6.40 BSC			0.252 BSC		
E1	4.30	4.40	4.50	0.169	0.173	0.177
e	0.65 BSC			0.026 BSC		
L	0.45	0.60	0.75	0.018	0.024	0.030
L1	1.00 REF			0.039 REF		
L2	0.25 BSC			0.010 BSC		
R	0.09	—	—	0.035	—	—
R1	0.09	—	—	0.035	—	—
0	12° REF		12° REF		—	
01	0°	—	8°	0°	—	8°
D	4.90	5.00	5.10	0.193	0.197	0.200
N	16			16		

		<b>EXAR CORPORATION</b> <small>REVISION CONTROL</small>	
Packaging Approval:		Drawing No.:	
Date: 11/21/07		Revision: C	
By: JL		Sheet: 1 OF 1	

## ORDERING INFORMATION<sup>(1)</sup>

Part Number	Operating Temperature Range	Lead-Free	Package	Package Method
SP3220EBCA-L/TR	0°C to 70°C	Yes <sup>(2)</sup>	SSOP	Tape and Reel
SP3220EBCY-L/TR	0°C to 70°C		TSSOP	Tape and Reel
SP3220EBCY-L	0°C to 70°C		TSSOP	Rail
SP3220EBEA-L/TR	-40°C to 85°C		SSOP	Tape and Reel
SP3220EBEA-L	-40°C to 85°C		SSOP	Rail
SP3220EBEY-L/TR	-40°C to 85°C		TSSOP	Tape and Reel
SP3220EBEY-L	-40°C to 85°C		TSSOP	Rail
SP3220ECA-L/TR	0°C to 70°C		SSOP	Tape and Reel
SP3220ECA-L	0°C to 70°C		SSOP	Rail
SP3220ECY-L/TR	0°C to 70°C		TSSOP	Tape and Reel
SP3220ECY-L	0°C to 70°C		TSSOP	Rail
SP3220EEA-L/TR	-40°C to 85°C		SSOP	Tape and Reel
SP3220EEA-L	-40°C to 85°C		SSOP	Rail
SP3220EEY-L/TR	-40°C to 85°C		TSSOP	Tape and Reel
SP3220EEY-L	-40°C to 85°C		TSSOP	Rail
SP3220EUEY-L/TR	-40°C to 85°C		TSSOP	Tape and Reel

**NOTES:**

1. Refer to [www.exar.com/SP3220E](http://www.exar.com/SP3220E), [www.exar.com/SP3220EB](http://www.exar.com/SP3220EB), [www.exar.com/SP3220EU](http://www.exar.com/SP3220EU) for the most up-to-date Ordering Information.
2. Visit [www.exar.com](http://www.exar.com) for additional information on Environmental Rating.

## REVISION HISTORY

Date	Revision	Description
08/30/05	--	Legacy Sipex Datasheet
02/02/11	1.0.0	Convert to Exar Format and update ordering information.
06/03/11	1.0.1	Remove SP3220EUCA-L(/TR) and SP3220EUEA-L(/TR) per PDN 110510-01
10/20/16	1.0.2	Update input voltage range of receiver from +/-25V to +/-15V, update ordering information table, remove WSOIC package information

### Notice

EXAR Corporation reserves the right to make changes to any products contained in this publication in order to improve design, performance or reliability. EXAR Corporation assumes no representation that the circuits are free of patent infringement. Charts and schedules contained herein are only for illustration purposes and may vary depending upon a user's specific application. While the information in this publication has been carefully checked; no responsibility, however, is assumed for inaccuracies.

EXAR Corporation does not recommend the use of any of its products in life support applications where the failure or malfunction of the product can reasonably be expected to cause failure of the life support system or to significantly affect its safety or effectiveness. Products are not authorized for use in such applications unless EXAR Corporation receives, in writing, assurances to its satisfaction that: (a) the risk of injury or damage has been minimized ; (b) the user assumes all such risks; (c) potential liability of EXAR Corporation is adequately protected under the circumstances.

Copyright 2012-16 EXAR Corporation



Datasheet October 2016

For technical questions please email Exar's Serial Technical Support group at: [serialtechsupport@exar.com](mailto:serialtechsupport@exar.com)







Reproduction, in part or whole, without the prior written consent of EXAR Corporation is prohibited.

## Looking for pricing, stock, or lifecycle information?

Click below to explore more details on WIN SOURCE:

-  [View SP3220EUEA-L on WIN SOURCE](#)
-  [Exar Corporation](#) Information

## Optimize Your Supply Chain with WIN SOURCE Solutions

-  Global Sourcing Solution
-  Obsolete Management
-  Cost Control Management
-  Shortage Management
-  Alternative Solution
-  Excess Inventory Management