



# Dual DC/DC Converter with USB Power Manager and Li-Ion Battery Charger

## FEATURES

- **Seamless Transition between Input Power Sources: Li-Ion Battery, USB, and 5V Wall Adapter**
- **Accurate USB Current Limiting (500mA/100mA)**
- **Two High Efficiency DC/DC Converters: Up to 96%**
- **Thermal Regulation Maximizes Battery Charge Rate without Risk of Overheating**
- Full-Featured Li-Ion Battery Charger with 4.2V Float Voltage for LTC3455 and 4.1V for LTC3455-1
- 4.1V Float Voltage (LTC3455-1) Improves Battery Life and High Temperature Safety Margin
- Hot Swap™ Output for SDIO and Memory Cards
- Pin-Selectable Burst Mode® Operation
- Output Disconnect: All Outputs Discharged to Ground During Shutdown
- Available in a 4mm × 4mm × 0.75mm 24-Pin QFN Package

## APPLICATIONS

- Handheld Computers
- Digital Cameras
- MP3 Players

## DESCRIPTION

The LTC®3455/LTC3455-1 are complete power management solutions for a variety of portable applications. These devices contain two synchronous step-down DC/DC converters, a USB power controller, a full-featured Li-Ion battery charger, a Hot Swap output, a low-battery indicator, and numerous internal protection features. The LTC3455/LTC3455-1 provide a small, simple solution for obtaining power from three different power sources: a single-cell Li-Ion battery, a USB port, and a wall adapter. Current drawn from the USB bus is accurately limited under all conditions. Whenever a USB or a wall adapter is present, the battery charger is enabled and all internal power for the device is drawn from the appropriate external power source. All outputs are discharged to ground during shutdown to provide complete output disconnect. These devices are available in a 4mm × 4mm 24-pin exposed-pad QFN package.

LT, LT, LTC, LTM and Burst Mode are registered trademarks of Linear Technology Corporation. Hot Swap is a trademark of Linear Technology Corporation. All other trademarks are the property of their respective owners. Protected by U.S. Patents including 6522118.

## TYPICAL APPLICATION

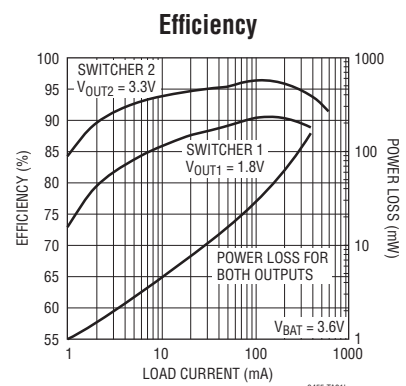
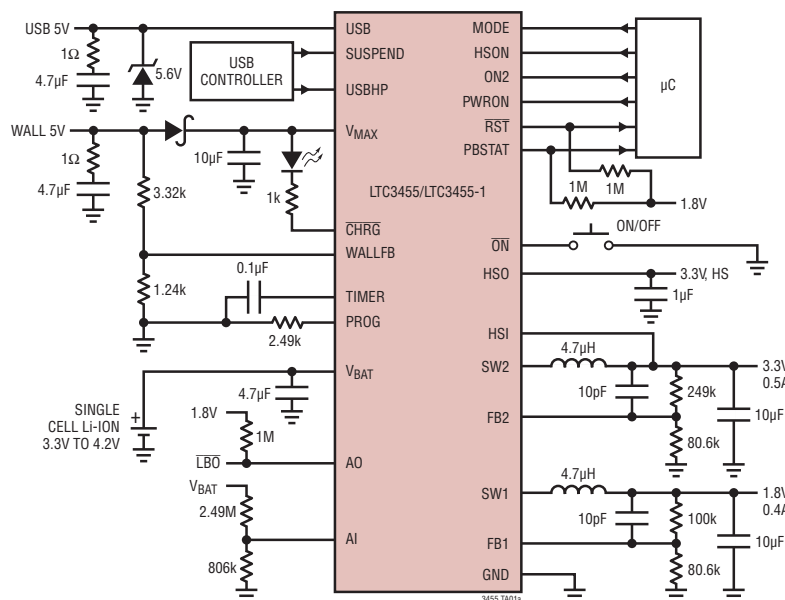

## ABSOLUTE MAXIMUM RATINGS

(Note 1)

Transient ( $t < 1\text{ms}$  and Duty Cycle  $< 1\%$ ):

$V_{\text{MAX}}$  USB Voltages.....  $-0.3\text{V}$  to  $7\text{V}$   
Steady State:

$V_{\text{BAT}}$ ,  $V_{\text{MAX}}$ , USB Voltages .....  $-0.3\text{V}$  to  $6\text{V}$   
SW1, SW2 Voltages .....  $-0.3\text{V}$  to  $(V_{\text{MAX}} + 0.3\text{V})$   
TIMER Voltage .....  $-0.3\text{V}$  to  $(V_{\text{MAX}} + 0.3\text{V})$   
PWRON,  $\overline{\text{ON}}$ , ON2, HSON Voltages .....  $-0.3\text{V}$  to  $6\text{V}$   
PBSTAT,  $\overline{\text{RST}}$ ,  $\overline{\text{CHRG}}$ , AO Voltages .....  $-0.3\text{V}$  to  $6\text{V}$   
HSI, HSO Voltages .....  $-0.3\text{V}$  to  $6\text{V}$   
MODE, USBHP, SUSPEND Voltages.....  $-0.3\text{V}$  to  $6\text{V}$   
WALLFB, AI, PROG Voltages.....  $-0.3\text{V}$  to  $2\text{V}$   
FB1, FB2 Voltages .....  $-0.3\text{V}$  to  $2\text{V}$   
Junction Temperature .....  $125^\circ\text{C}$   
Operating Temperature Range (Note 2)....  $-40^\circ\text{C}$  to  $85^\circ\text{C}$   
Storage Temperature Range- .....  $-65^\circ\text{C}$  to  $125^\circ\text{C}$

## PIN CONFIGURATION

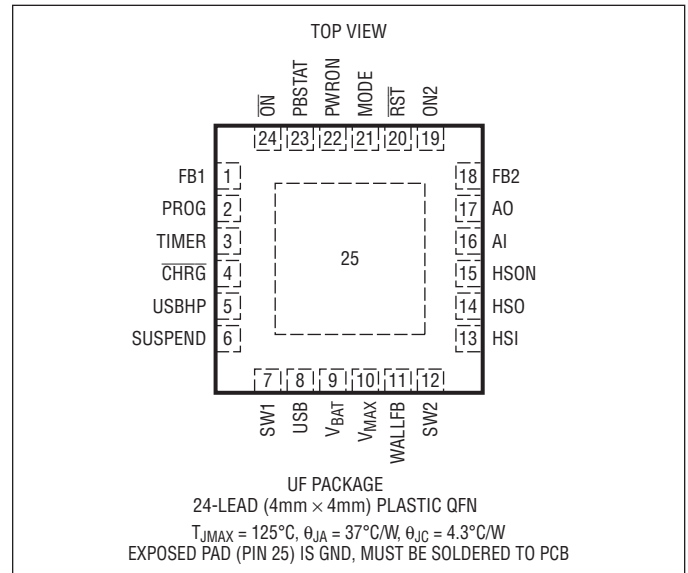

## ORDER INFORMATION

LEAD FREE FINISH	TAPE AND REEL	PART MARKING	PACKAGE DESCRIPTION	TEMPERATURE RANGE
LTC3455EUF#PBF	LTC3455EUF#TRPBF	3455	24-Lead (4mm × 4mm) Plastic QFN	$-40^\circ\text{C}$ to $85^\circ\text{C}$
LTC3455EUF-1#PBF	LTC3455EUF-1#TRPBF	34551	24-Lead (4mm × 4mm) Plastic QFN	$-40^\circ\text{C}$ to $85^\circ\text{C}$

Consult LTC Marketing for parts specified with wider operating temperature ranges.

Consult LTC Marketing for information on non-standard lead based finish parts.

For more information on lead free part marking, go to: <http://www.linear.com/leadfree/>

For more information on tape and reel specifications, go to: <http://www.linear.com/tapeandreeel/>

**ELECTRICAL CHARACTERISTICS** The ● denotes the specifications which apply over the full operating temperature range, otherwise specifications are at  $T_{\text{A}} = 25^\circ\text{C}$ .  $V_{\text{BAT}} = 3.6\text{V}$ ,  $V_{\text{MAX}} = 3.6\text{V}$ ,  $V_{\text{PWRON}} = 2\text{V}$ ,  $V_{\overline{\text{ON}}}$  is open,  $V_{\text{ON2}} = 0\text{V}$ ,  $V_{\text{USB}} = 0\text{V}$ ,  $V_{\text{WALLFB}} = 0\text{V}$  unless otherwise noted.

PARAMETER	CONDITIONS	MIN	TYP	MAX	UNITS
Battery Undervoltage Lockout Voltage	$V_{\text{BAT}}$ Rising	2.9	3.0	3.2	V
Battery Undervoltage Lockout Hysteresis			450		mV
$V_{\text{BAT}}$ Pin Quiescent Current (Note 3)					$\mu\text{A}$
Burst Mode, Battery Powered	$V_{\text{ON2}} = V_{\text{MODE}} = 1\text{V}$ , Not Switching		110	160	$\mu\text{A}$
PWM Mode, Battery Powered	$V_{\text{ON2}} = 1\text{V}$ , $V_{\text{MODE}} = 0\text{V}$ , Not Switching		500	800	$\mu\text{A}$
USB Powered	$V_{\text{USB}} = 5\text{V}$ , Charger Off		10	20	$\mu\text{A}$
Wall Powered	$V_{\text{WALL}} = 1.5\text{V}$ , $V_{\text{MAX}} = 4.5\text{V}$ , Charger Off		10	20	$\mu\text{A}$
Shutdown	$V_{\text{PWRON}} = 0\text{V}$ , $V_{\text{MAX}} = 0\text{V}$		2	4	$\mu\text{A}$
$\overline{\text{ON}}$ Pin Threshold			0.8	1.1	V
PWRON Pin Threshold			0.8	1.0	V
ON2 Pin Threshold			0.8	1.0	V
MODE Pin Threshold			0.8	1.0	V
WALLFB Pin Threshold Voltage	WALLFB Rising ●	1.20	1.23	1.26	V
WALLFB Pin Hysteresis			60		mV

**ELECTRICAL CHARACTERISTICS** The ● denotes the specifications which apply over the full operating temperature range, otherwise specifications are at  $T_A = 25^\circ\text{C}$ .  $V_{\text{BAT}} = 3.6\text{V}$ ,  $V_{\text{MAX}} = 3.6\text{V}$ ,  $V_{\text{PWRON}} = 2\text{V}$ ,  $V_{\text{ON1}}$  is open,  $V_{\text{ON2}} = 0\text{V}$ ,  $V_{\text{USB}} = 0\text{V}$ ,  $V_{\text{WALLFB}} = 0\text{V}$  unless otherwise noted.

PARAMETER	CONDITIONS		MIN	TYP	MAX	UNITS
ON Pin Pullup Current	$V_{\text{ON}} = 1\text{V}$			2.5		$\mu\text{A}$
PWRON Pin Pulldown Current	$V_{\text{PWRON}} = 1\text{V}$			2.5		$\mu\text{A}$
ON2 Pin Pulldown Current	$V_{\text{ON2}} = 1\text{V}$			2.5		$\mu\text{A}$
MODE Pin Pullup Current	$V_{\text{MODE}} = 1\text{V}$			2.5		$\mu\text{A}$
WALLFB Pin Input Bias Current	$V_{\text{WALLFB}} = 1.35\text{V}$	●		$\pm 1$	$\pm 30$	nA
PBSTAT Pin Low Voltage	$V_{\text{ON}} = 0\text{V}$ , $I_{\text{PBSTAT}} = 100\mu\text{A}$ $V_{\text{ON}} = 0\text{V}$ , $I_{\text{PBSTAT}} = 1\text{mA}$			0.02 0.20	0.10 0.35	V V
RST Pin Low Voltage	$I_{\text{RST}} = 100\mu\text{A}$ $I_{\text{RST}} = 1\text{mA}$			0.02 0.20	0.10 0.35	V V
RST Pulse Duration	After FB1 and FB2 in Regulation			200		ms
<b>Battery-<math>V_{\text{MAX}}</math> PMOS</b>						
$V_{\text{MAX}}$ PMOS Switch On-Resistance				0.15		$\Omega$
$V_{\text{MAX}}$ Switch Current Limit			2.5	4.0		A
$V_{\text{MAX}}$ Switch Current Limit at Startup	With $V_{\text{MAX}}$ Rising, $V_{\text{MAX}} = 3\text{V}$ , $V_{\text{BAT}} = 3.6\text{V}$		0.4	0.9		A
<b>Gain Block</b>						
AI Pin Threshold Voltage		●	0.784	0.805	0.826	V
AI Pin/FB2 Pin Voltage Difference	$V_{\text{FB2}} - V_{\text{AI}}$		-8	0	8	mV
AI Pin Input Bias Current	$V_{\text{AI}} = 0.85\text{V}$	●		$\pm 1$	$\pm 25$	nA
AO Pin Sink Current	$V_{\text{AI}} = 0.6\text{V}$ , $V_{\text{AO}} = 1.5\text{V}$		1.0	1.8	2.5	mA
AO Pin Voltage	$V_{\text{AI}} = 0.6\text{V}$ , $I_{\text{AO}} = 1\text{mA}$			0.8	1.2	V
<b>Switching Regulators</b>						
FB1, FB2 Voltage		●	0.784	0.805	0.826	V
FB1, FB2 Voltage Line Regulation	$V_{\text{MAX}} = 3\text{V}$ to $5\text{V}$			0.01		%/V
FB1, FB2 Voltage Burst Mode Hysteresis	$V_{\text{MODE}} = 2\text{V}$			8		mV
FB1, FB2 Pin Input Bias Current	$V_{\text{FB1}} = V_{\text{FB2}} = 0.85\text{V}$	●		$\pm 1$	$\pm 25$	nA
Switching Frequency	Both Switchers		1.2	1.5	1.8	MHz
PMOS Switch On-Resistance	Both Switchers			0.35		$\Omega$
NMOS Switch On-Resistance	Both Switchers			0.45		$\Omega$
PMOS Switch Current Limit	Switcher 1 Switcher 2		450 700	600 900	850 1300	mA mA
<b>USB Power Manager</b>						
USB Undervoltage Lockout Voltage	From Low to High		3.75	3.90	4.10	V
USB Undervoltage Lockout Hysteresis				150		mV
USB Minimum Voltage to Charge Battery				4.0		V
USB PMOS Switch On-Resistance	$V_{\text{USB}} = 5\text{V}$			0.5		$\Omega$
USB Current Limit	$V_{\text{USB}} = 5\text{V}$ , $V_{\text{USBHP}} = 2\text{V}$ $V_{\text{USB}} = 5\text{V}$ , $V_{\text{USBHP}} = 0\text{V}$	● ●	440 60	475 80	500 100	mA mA
USB Suspend Mode Bias Current	$V_{\text{USB}} = 5\text{V}$ , $V_{\text{SUSPEND}} = 2\text{V}$			4	20	$\mu\text{A}$
SUSPEND Pin Threshold				0.8	1.1	V
USBHP Pin Threshold				0.8	1.1	V
SUSPEND Pin Pulldown Current	$V_{\text{SUSPEND}} = 0.5\text{V}$			2.5		$\mu\text{A}$
USBHP Pin Pulldown Current	$V_{\text{USBHP}} = 0.5\text{V}$			2.5		$\mu\text{A}$

# LTC3455/LTC3455-1

**ELECTRICAL CHARACTERISTICS** The ● denotes the specifications which apply over the full operating temperature range, otherwise specifications are at  $T_A = 25^\circ\text{C}$ .  $V_{\text{BAT}} = 3.6\text{V}$ ,  $V_{\text{MAX}} = 3.6\text{V}$ ,  $V_{\text{PWRON}} = 2\text{V}$ ,  $V_{\text{ON1}}$  is open,  $V_{\text{ON2}} = 0\text{V}$ ,  $V_{\text{USB}} = 0\text{V}$ ,  $V_{\text{WALLFB}} = 0\text{V}$  unless otherwise noted.

PARAMETER	CONDITIONS	MIN	TYP	MAX	UNITS
<b>Hot Swap Output</b>					
Hot Swap PMOS Switch On-Resistance	$V_{\text{HSI}} = 3.3\text{V}$		0.9		$\Omega$
Hot Swap PMOS Switch Current Limit	$V_{\text{HSI}} = 3.3\text{V}$ , $V_{\text{HSO}} = 2.5\text{V}$	120	160		mA
HSON Pin Threshold			0.8	1.1	V
HSON Pin Pulldown Current			2.5		$\mu\text{A}$
<b>Battery Charger</b>					
Regulated Charger $V_{\text{BAT}}$ Voltage	$0^\circ\text{C} \leq T_A \leq 85^\circ\text{C}$ (LTC3455) $0^\circ\text{C} \leq T_A \leq 85^\circ\text{C}$ (LTC3455-1)	4.158 4.058	4.200 4.1	4.242 4.142	V V
Charger Current Limit (USB Powered)	$R_{\text{PROG}} = 2.49\text{k}\Omega$ , $V_{\text{USBHP}} = 2\text{V}$ , $V_{\text{USB}} = 5\text{V}$ , $0^\circ\text{C} \leq T_A \leq 85^\circ\text{C}$ $R_{\text{PROG}} = 2.49\text{k}\Omega$ , $V_{\text{USBHP}} = 0\text{V}$ , $V_{\text{USB}} = 5\text{V}$ , $0^\circ\text{C} \leq T_A \leq 85^\circ\text{C}$	425	400 50	470 90	mA mA
Charger Current Limit (Wall Powered)	$R_{\text{PROG}} = 2.49\text{k}\Omega$ , $V_{\text{MAX}} = 4.5\text{V}$ , $0^\circ\text{C} \leq T_A \leq 85^\circ\text{C}$		500	575	mA
Recharge Battery Voltage Threshold	$V_{\text{BAT(REGULATED)}} - V_{\text{RECHARGE}}$		150		mV
Trickle Charge Trip Threshold	Battery Voltage Rising		2.85		V
Trickle Charge Trip Hysteresis			60		mV
Trickle Charge Current	$R_{\text{PROG}} = 2.49\text{k}\Omega$ , $V_{\text{BAT}} = 2\text{V}$		65		mA
PROG Pin Current	Internal Pull-Up Current, No $R_{\text{PROG}}$		2		$\mu\text{A}$
PROG Pin Voltage	$R_{\text{PROG}} = 2.49\text{k}\Omega$		1.23		V
CHRG Pin Output Low Voltage	$I_{\text{CHRG}} = 5\text{mA}$		0.75		V
Timer Accuracy	$C_{\text{TIMER}} = 0.1\mu\text{F}$		$\pm 10$		%
Junction Temperature in Constant Temperature Mode			105		$^\circ\text{C}$

**Note 1:** Stresses beyond those listed under Absolute Maximum Ratings may cause permanent damage to the device. Exposure to any Absolute Maximum Rating condition for extended periods may affect device reliability and lifetime.

**Note 2:** The LTC3455/LTC3455-1 are guaranteed to meet specified performance from  $0^\circ\text{C}$  to  $85^\circ\text{C}$  and is designed, characterized and

expected to meet these extended temperature limits, but is not 100% tested at  $-40^\circ\text{C}$  and  $85^\circ\text{C}$ .

**Note 3:** Quiescent current is pulled from the  $V_{\text{BAT}}$  pin when neither USB or wall power is present, and from the  $V_{\text{MAX}}$  pin when either USB or Wall power is present.

## TYPICAL PERFORMANCE CHARACTERISTICS

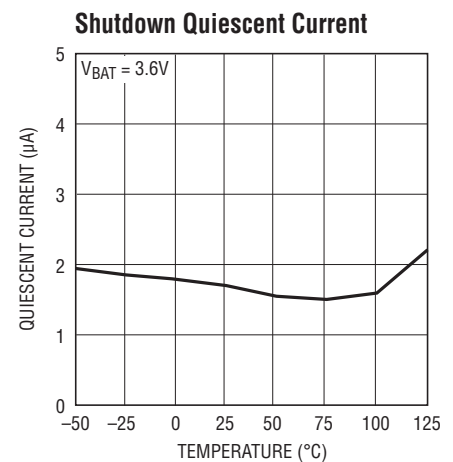
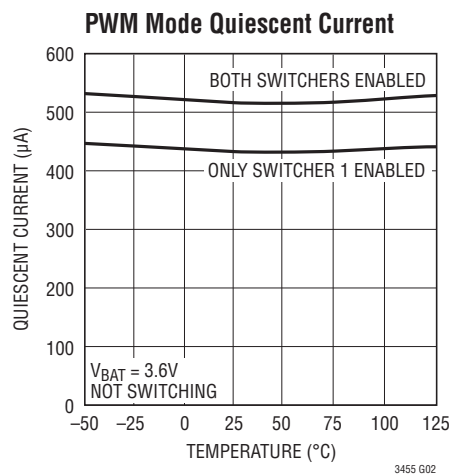
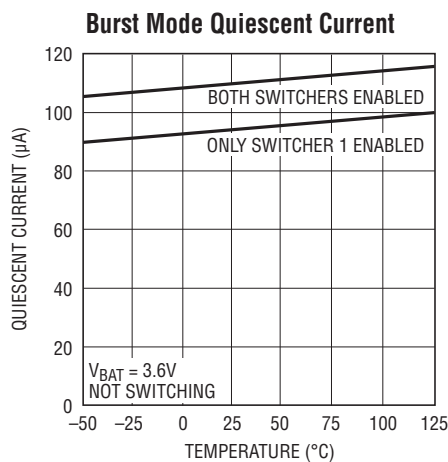

# TYPICAL PERFORMANCE CHARACTERISTICS

**Feedback Pins (FB1, FB2) and AI Pin Voltage**

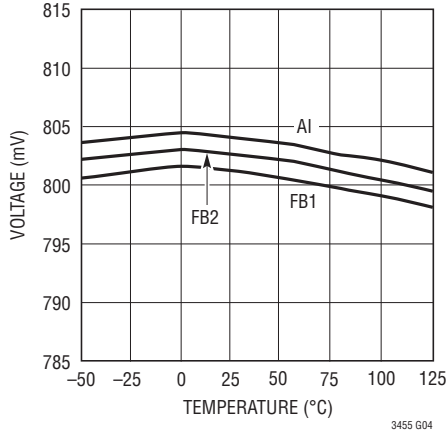

**Switching Regulator Oscillator Frequency**

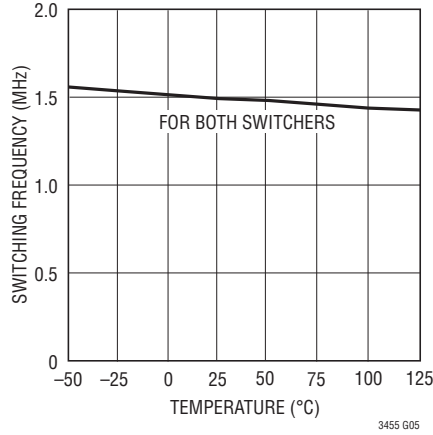

**Switching Regulator Current Limit**

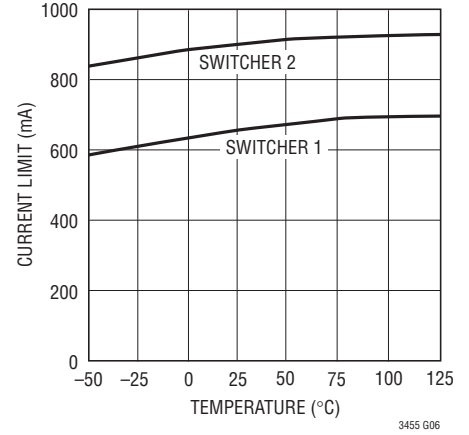

**USB Pin Current Limit**

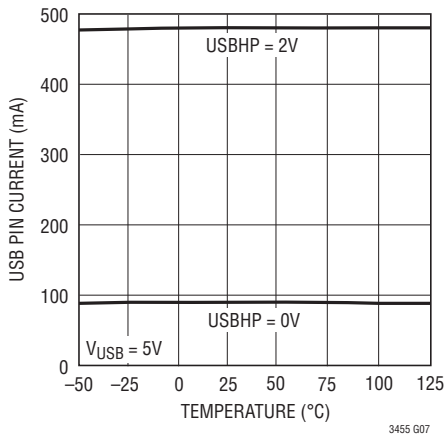

**V<sub>MAX</sub> Pin Current Limit**

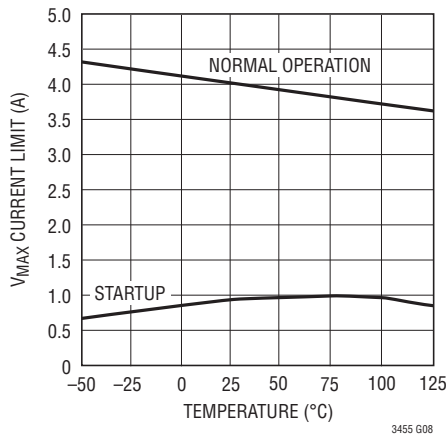

**HSO Pin Current Limit**

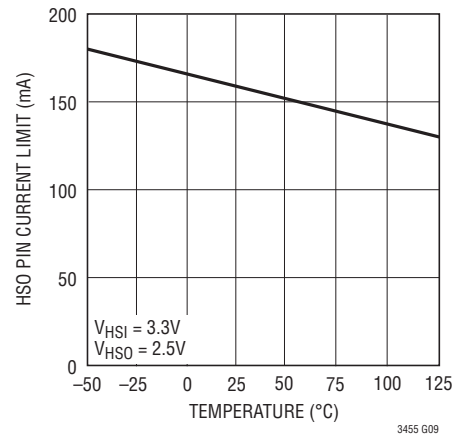

**Battery Undervoltage Lockout**

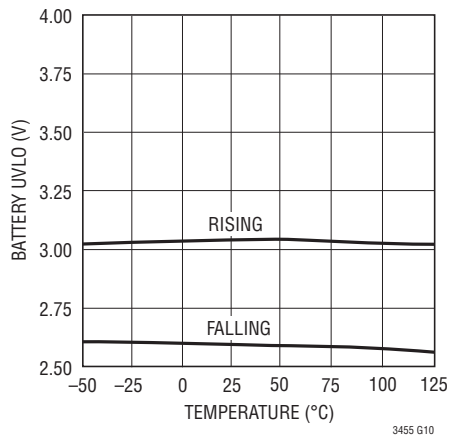

**USB Undervoltage Lockout**

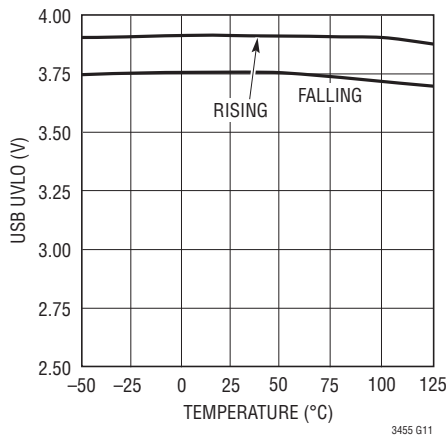

**WALLFB Trip Voltage**

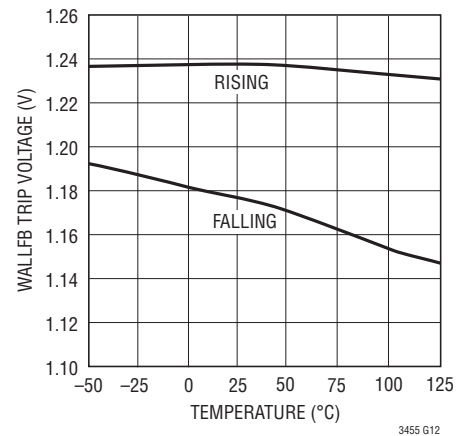

## TYPICAL PERFORMANCE CHARACTERISTICS

**Battery Charger Regulation Voltage**

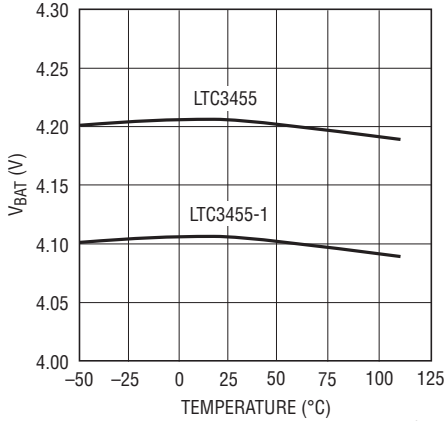

3455 G13

**Battery Charger Recharge Threshold**

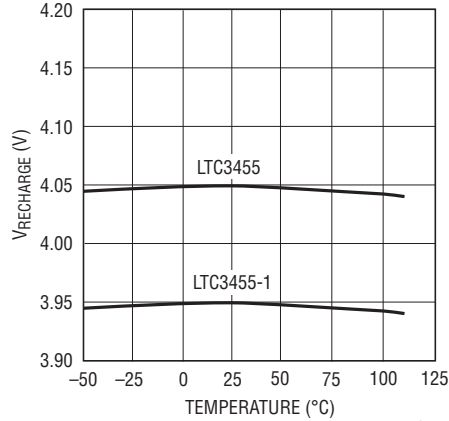

3455 G14

**Battery Charger Trickle-Charge Threshold**

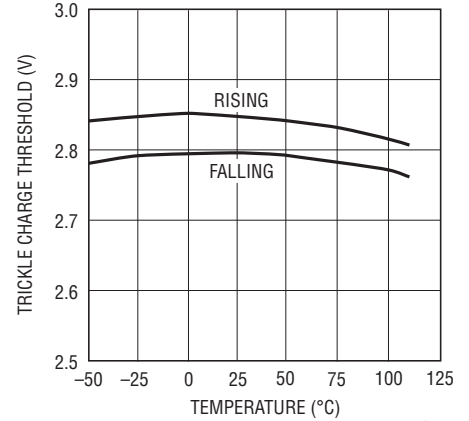

3455 G15

**Charge Current When Wall-Powered**

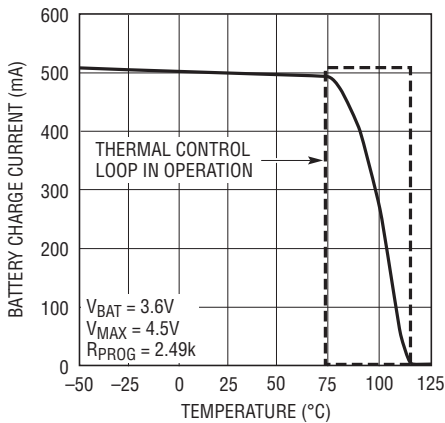

3455 G16

**Charge Current When USB-Powered**

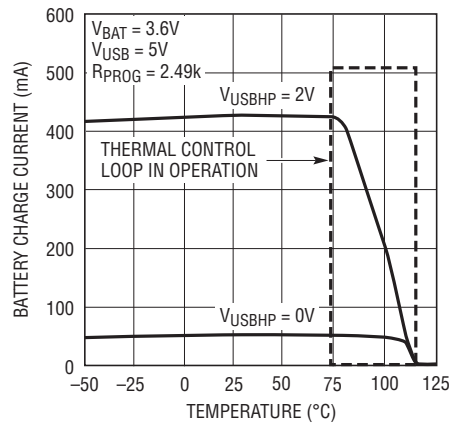

3455 G17

**Battery Current When USB- or Wall-Powered**

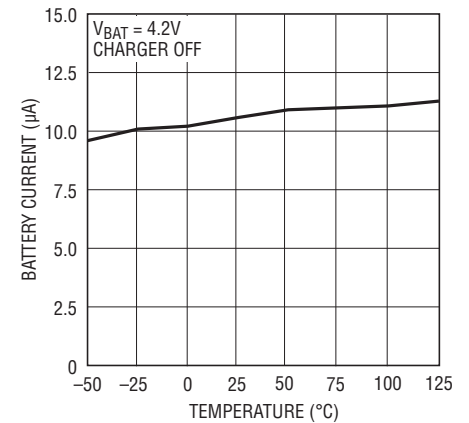

3455 G18

**PROG Pin Voltage vs Charge Current**

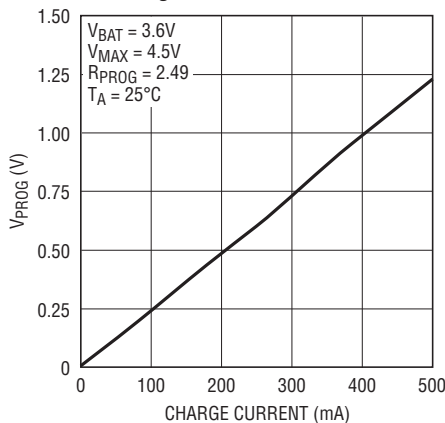

3455 G19

**$R_{DS(ON)}$  for Switching Regulator Power Switches**

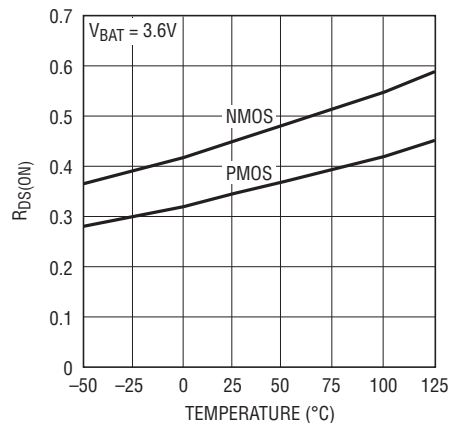

3455 G20

**$R_{DS(ON)}$  for  $V_{MAX}$ , USB, and HSO PMOS Switches**

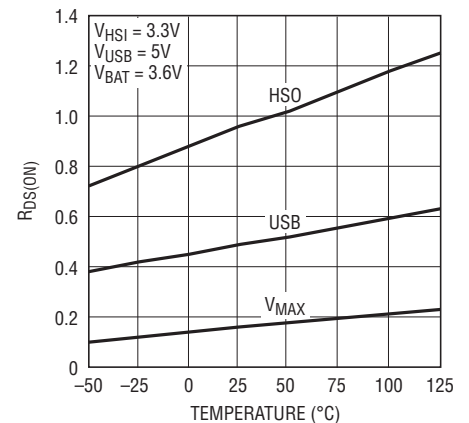

3455 G21

## PIN FUNCTIONS

**FB1 (Pin 1):** Feedback Pin for Switcher 1. Set the output voltage by connecting feedback resistors to this pin.

**PROG (Pin 2):** Charge Current Program and Charge Current Monitor Pin. Connect a resistor,  $R_{\text{PROG}}$ , from this pin to ground to program battery charge current.

$$I_{\text{BAT}} = 1000 \cdot 1.23\text{V} / R_{\text{PROG}}$$

In all modes the voltage on the PROG pin can be used to measure charge current. PROG has a weak pull-up current source to turn the charger off if the pin is left open.

**TIMER (Pin 3):** Timer Capacitor Pin. Connect a capacitor,  $C_{\text{TIMER}}$ , between this pin and ground to set the charge cycle termination time. The timer starts when USB or wall power is first present. The timer period is:

$$T_{\text{TIMER}} \text{ (hours)} = C_{\text{TIMER}} \cdot (3 \text{ hours}) / (0.1\mu\text{F})$$

Tie TIMER to ground to disable just the internal timer function. Tie TIMER to  $V_{\text{MAX}}$  to use the charger in a constant-current-only mode (which disables the timer, voltage amplifier and trickle charge function).

**CHRG (Pin 4):** Open-Drain Charge Status Pin. This pin is pulled low with an internal N-channel MOSFET whenever the battery charger is enabled, and is forced into a high impedance state whenever it is disabled.

**USBHP (Pin 5):** USB High Power Mode Pin. This pin is used to select the appropriate USB current limit (either 500mA or 100mA). Pull high to select 500mA (high power mode); low to select 100mA (low power mode).

**SUSPEND (Pin 6):** USB Suspend Pin. When this pin is pulled high, the internal USB power controller is disabled and the USB pin current reduces to less than 20 $\mu$ A.

**SW1 (Pin 7):** Switch Pin for Switcher 1. Minimize the length of the metal trace connected to this pin. Place the inductor for Switcher 1 as close to this pin as possible.

**USB (Pin 8):** USB Supply Pin. Input current into this pin is limited to either 100mA or 500mA based on the state of the USBHP pin. The charger and Switcher 1 will remain alive whenever USB power is present (when USB pin is above 3.9V and SUSPEND is low).

**$V_{\text{BAT}}$  (Pin 9):** Battery Input Pin. Bypass this pin with a capacitor as close to the device as possible.

**$V_{\text{MAX}}$  (Pin 10):** Max Voltage Pin. This pin is used to power the two internal step-down DC/DC converters and is provided externally to power other devices (i.e. LDOs or Switchers for LCD bias, white LED backlight drive, etc). When the LTC3455/LTC3455-1 is on and neither USB or wall power are available, an internal PMOS switch connects this pin to the  $V_{\text{BAT}}$  pin. When either USB or wall power is present, they provide power to this pin, and the battery charger draws power from this pin. In shutdown, this pin is discharged to ground to provide output disconnect.

**WALLFB (Pin 11):** Wall Power Detection Pin. This pin is the input to a comparator used to signal the presence of a 5V wall adapter. A resistor divider taken from the wall adapter input is connected to this pin to tell the LTC3455/LTC3455-1 when the adapter voltage is high enough to provide power to the LTC3455/LTC3455-1. When this pin is higher than 1.23V, the battery charger is enabled. The 5V wall adapter is connected to the  $V_{\text{MAX}}$  pin through a Schottky diode. Tie WALLFB to ground if a wall adapter is not used.

**SW2 (Pin 12):** Switch Pin for Switcher 2. Minimize the length of the metal trace connected to this pin. Place the inductor for Switcher 2 as close to this pin as possible.

**HSI (Pin 13):** Hot Swap Input Pin. This pin is connected to the HSO pin through a current-limited PMOS switch.

**HSO (Pin 14):** Hot Swap Output Pin. This output is used for memory cards or other devices that would appear as a short if they were hot-plugged directly to one of the outputs (typically the 3.3V output). The current out of this pin is limited to 160mA.

**HSON (Pin 15):** Hot Swap Enable Pin. This pin turns on the PMOS that connects the HSI and HSO pins.

**AI (Pin 16):** Gain Block Input Pin. This pin is the inverting input to an amplifier that can be used as a low-battery detector or as an LDO with the addition of an external PNP or PMOS. The non-inverting input of the gain block is connected to the 0.8V internal reference.

**AO (Pin 17):** Gain Block Output Pin. This pin is an open-drain output, and is pulled low when the AI pin is less than 800mV. This output can be used as a low-battery detector, or as an LDO with the addition of an external PNP or PMOS. This pin can sink up to 1mA.

## PIN FUNCTIONS

**FB2 (Pin 18):** Feedback Pin for Switcher 2. Set the output voltage by connecting feedback resistors to this pin.

**ON2 (Pin 19):** Enable Pin for Switcher 2. This pin turns on Switcher 2 only if  $\overline{ON}$  is low or PWRON is high. Switcher 2 cannot be turned on by itself.

**$\overline{RST}$  (Pin 20):** Reset Pin. This pin is an open-drain output that provides a 200ms reset signal during power-up to initialize a microcontroller.

**MODE (Pin 21):** Burst Mode Enable Pin. Tie this pin high to allow Burst Mode operation for the LTC3455/LTC3455-1. Burst Mode operation will provide superior efficiency when both outputs are operating with very low output currents. Tie this pin to ground to force PWM operation under all load current conditions. Burst Mode is disabled initially at startup (for 200ms) and also whenever external power is available (even if MODE is pulled high).

**PWRON (Pin 22):** Power-On Pin. Pull this pin high to turn on the LTC3455/LTC3455-1. This pin is typically used in conjunction with the  $\overline{ON}$  and PBSTAT pins, and a momentary-on switch. Tie PWRON to ground if not used.

**PBSTAT (Pin 23):** Push-Button Status Pin. This pin is an open drain output that indicates the state of the  $\overline{ON}$  pin (which is usually connected to a momentary-on push-button) to the microcontroller. This pin follows the state of the  $\overline{ON}$  pin (PBSTAT goes low when  $\overline{ON}$  is pulled low).

**$\overline{ON}$  (Pin 24):**  $\overline{ON}$  Pin. Pull this pin to ground to turn on the LTC3455/LTC3455-1. This pin is typically used with a momentary-on push-button switch to turn on the LTC3455/LTC3455-1. This pin would be held low until the PWRON pin is pulled high by a microcontroller to keep the LTC3455/LTC3455-1 turned on. If a momentary-on switch is not used, this pin can be held to ground to keep on the LTC3455/LTC3455-1. Leave  $\overline{ON}$  open if not used. This pin has a weak pull-up current source.

**GND (Pin 25 – Exposed Pad):** Ground Pin. The exposed backside pad is the only ground pin for the LTC3455/LTC3455-1 and must be soldered to the PC board ground plane for the device to operate properly.

## SIMPLIFIED BLOCK DIAGRAM

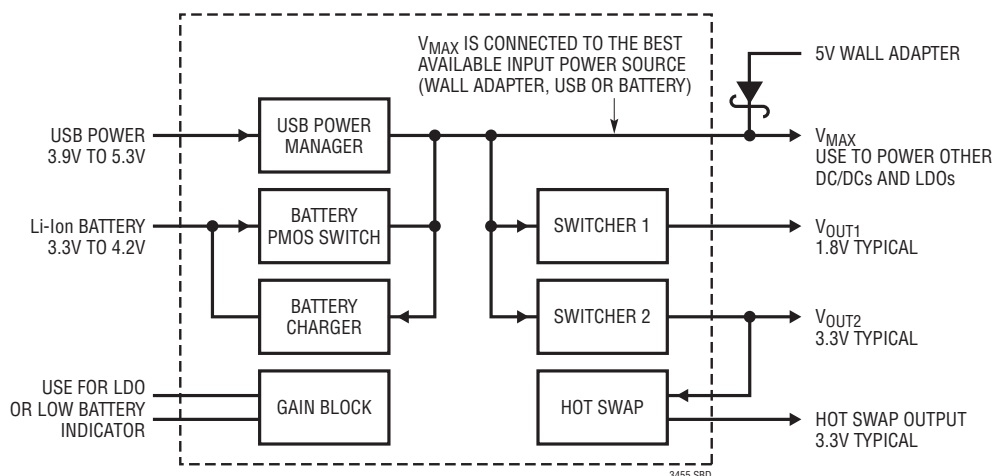

**BLOCK DIAGRAM**

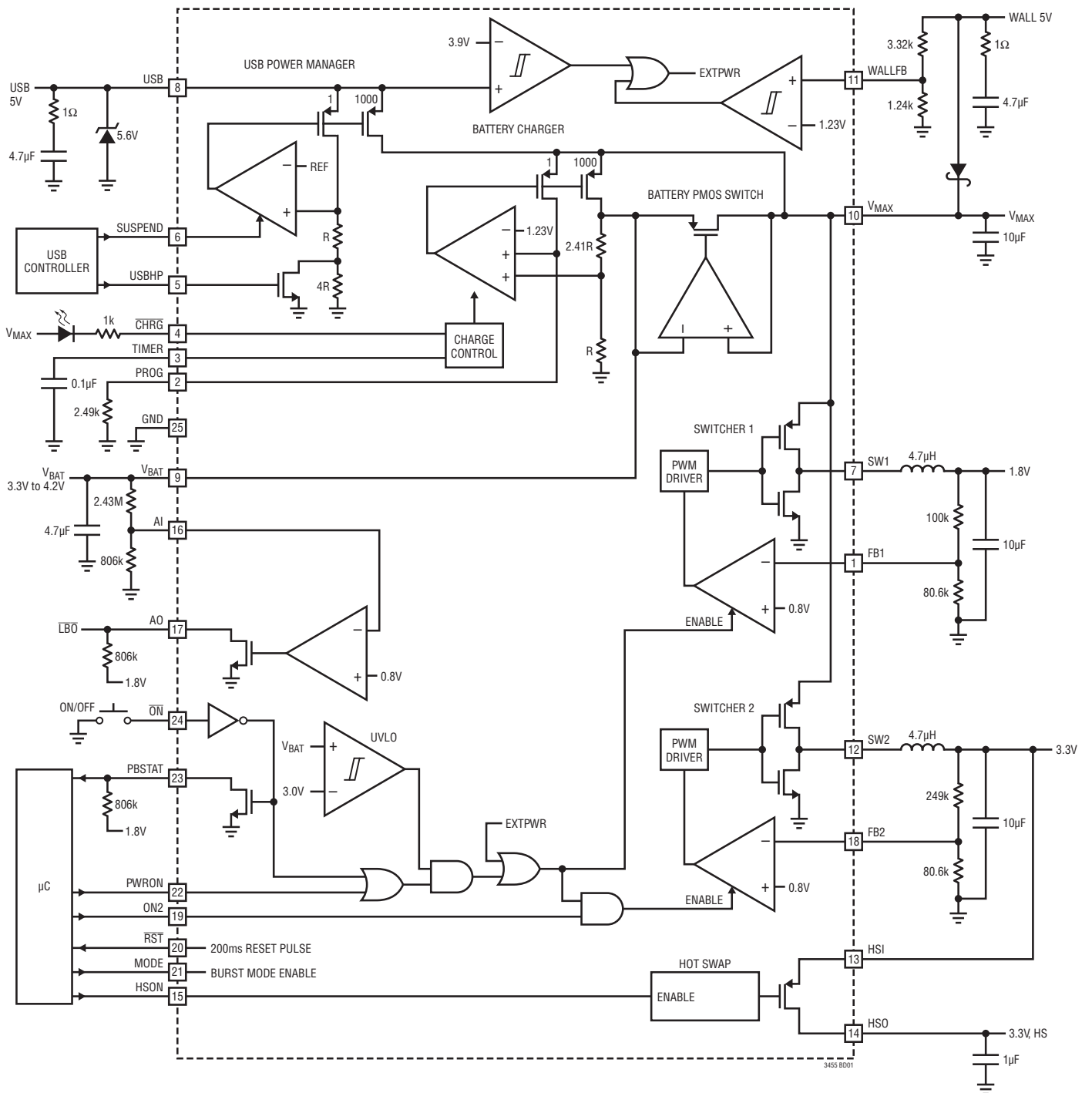

## OPERATION

The LTC3455/LTC3455-1 are designed to be a complete power management solution for a wide variety of portable systems. The device incorporates two current mode step-down switching regulators, a full-featured battery charger, a USB power controller, a Hot Swap output, a low-battery comparator (which can also be configured as an LDO) and numerous protection features into a single package. When only battery power is available, the battery PMOS switch connects the  $V_{MAX}$  pin to the  $V_{BAT}$  pin to provide power to both switching regulators (and any other devices powered from  $V_{MAX}$ ). When external power is applied, the

LTC3455/LTC3455-1 seamlessly transition from battery power (a single-cell Li-Ion cell) to either the USB supply or a wall adapter. The battery PMOS switch is turned off, the charger is activated and all internal power for the device is drawn from the appropriate external power source. Maximum charge current and charge time are programmed using an external resistor and capacitor, respectively. The USB power manager provides accurate current limiting for the USB pin under all conditions. The Hot Swap output is ideal for powering memory cards and other devices that can be inserted while the system is fully powered.

---

## APPLICATIONS INFORMATION

### Undervoltage Lockout (UVLO)

If no external power is present, the LTC3455/LTC3455-1 will start only if the battery voltage is above 3.0V. This prevents starting up with a battery that is too close to deep discharge. Once started, the battery must drop below 2.6V before the LTC3455/LTC3455-1 will shut off. This hysteresis is set intentionally large to prevent the LTC3455/LTC3455-1 from turning off at an inappropriate time, like during the read- or write-cycle of a hard-disk drive (which could potentially damage the drive). The internal UVLO is meant only as a last chance safety measure to prevent running the battery voltage too low and damaging it. An accurate, user-settable low-battery threshold can be implemented using the gain block (see the “Gain Block” section for details) which gives the microcontroller complete control over the timing of a shutdown due to a low-battery condition.

If external power is present and the battery voltage is less than 3.0V, the  $V_{MAX}$  pin voltage must be greater than 3.9V for the LTC3455/LTC3455-1 to start, and once started, the  $V_{MAX}$  pin must stay above 3.1V for the device to continue running.

### Selecting the Input Power Source

The priority for supplying power to both DC/DC converters, all internal circuitry, and the  $V_{MAX}$  pin is: Wall adapter, USB, battery.

Whenever the WALLFB pin is above 1.23V, system power is drawn from the wall adapter via the  $V_{MAX}$  pin, and the battery charger is active. The 5V wall adapter output is connected to the  $V_{MAX}$  pin through a Schottky diode, and a resistor divider from the 5V wall input is connected to the WALLFB pin to signal the LTC3455/LTC3455-1 that wall power is present. A higher voltage adapter can also be used, but the 6V maximum rating on the  $V_{MAX}$  pin requires the use of an additional regulator to step down the voltage.

If USB power is present and above 3.9V (and wall power is not available), system power is drawn from the USB pin. The battery charger is active, but charge current will be held off until the USB pin increases above 4.0V to prevent the battery charger from further loading down an already low USB supply. As long as the USB pin stays above 3.9V, the USB port supplies all other system power.

If the system needs more power than the USB bus can supply, the charger turns off completely, the USB power controller becomes a 500mA (or 100mA) current source and the  $V_{MAX}$  voltage begins to decrease. If  $V_{MAX}$  continues to decrease, eventually the battery will provide the additional current needed. This allows the LTC3455/LTC3455-1 to withstand load current transients that briefly require more power than the USB power supply can provide.

## APPLICATIONS INFORMATION

### Operation When No Battery Is Present

As long as USB or wall power is available, the LTC3455/LTC3455-1 will operate with no battery present, a crucial requirement for systems with a removable battery. Keep in mind, however, that if the LTC3455/LTC3455-1 are USB powered and the battery is not present, absence of the battery means that there is no reservoir if the system needs more power than the USB port can supply. This is especially a problem when starting up the LTC3455/LTC3455-1 in USB low power mode with no battery present, which is discussed in greater detail on the next page, in the section entitled “Startup Issues in USB Low Power Mode When No Battery is Present”. Similarly, if external power is available, the LTC3455/LTC3455-1 will operate even if the battery is bad or in deep-discharge.

The LTC3455/LTC3455-1 are also a good choice for systems that are always powered by a USB supply or wall adapter. The charger can then be used to charge a large capacitor or backup battery, which can briefly provide power to the system after the external power has been removed. This gives the microcontroller enough time to follow proper shutdown procedures even after the main power source is abruptly removed. If USB powered, the large capacitor or backup battery will also be used to provide additional current if the system briefly needs more power than the USB bus can provide.

### Concerns When Wall Adapter Powered

Always choose a wall adapter that can provide power for all load and battery charging requirements. Choosing a wall adapter with a power rating that is too small will result in very long charge times and erratic system operation. If the total current needed (load and battery charging) exceeds what the adapter can provide, the voltage on the  $V_{MAX}$  pin will begin to droop. If it droops close enough to the battery voltage (the  $V_{BAT}$  pin), the charge current decreases and eventually reduces to zero. If the load current is still too much for the wall adapter to provide, the wall adapter will provide what it can and the battery will provide the

rest. When wall powered, this operation is intended only for surviving fault conditions and should not be a normal mode of operation.

### Concerns When USB Powered

The popularity of USB (Universal Serial Bus) makes it an attractive choice for transferring data in a variety of portable devices. Therefore, utilizing the USB port to power these portable devices while charging their battery is very desirable, but it is not necessarily an easy task. As the performance of digital cameras, handheld computers, and MP3 players increases, the power needed to operate them also increases. The power available from a single USB port (maximum 2.5W) is barely enough to support the peak power needed by many full-featured portable devices, even without the power needed to quickly charge their batteries.

To further complicate matters, a USB port is not the ideal power source. Each device can draw a maximum of 500mA (in high power mode), but the voltage provided to the portable device can vary quite significantly. Although a USB power supply has a 5V nominal rating, when you include normal supply variations, cable losses, and transient conditions, the USB voltage showing up at the portable device is typically much lower—often falling to only 4V. Since the USB port has a strict current limit of 500mA, this means the amount of power available to the portable device can be as low as 2W. The reduced USB voltage also presents problems when trying to fully charge a single-cell Lithium-Ion battery when the USB voltage may itself be below or near the float voltage.

The LTC3455/LTC3455-1 are specifically designed to alleviate these problems and make the most of the power the USB port has to offer. See the sections entitled “Large Transient Loads when USB powered” and “Special Charger Features when USB powered” for more detailed discussions of the LTC3455/LTC3455-1’s special USB features.

## APPLICATIONS INFORMATION

### USB High Power/Low Power/Suspend Modes

There are three basic modes for the USB power manager: high power, low power, and suspend. High power mode allows the LTC3455/LTC3455-1 to draw up to 500mA from the USB port, and is selected by pulling the USBHP pin high. Low power mode reduces the allowable current drawn to 100mA, and is selected by pulling the USBHP pin low. The USBHP pin has a weak internal pulldown current source to ensure that the LTC3455/LTC3455-1 always start up in USB low power mode. The SUSPEND pin will disable the USB power manager completely, reducing the USB pin current to under 20 $\mu$ A.

### Operation in USB Low Power Mode

Most applications that draw power from the USB bus should be in low power mode only for a brief amount of time. Devices should be in low power mode (draw no more than 100mA of current from the USB bus) upon power-up, and can transition to high power mode (draw up to 500mA from the USB bus) after the device has been given permission to do so by the USB host controller. The change to high power mode is usually very quick, so the full 500mA of current is available shortly after connecting to the USB bus. While the LTC3455/LTC3455-1 will operate when in low power mode, the amount of power available is so small that it is difficult or impossible to charge a battery or even provide enough current to power the rest of the system. For this reason, USB high power operation should always be used with the LTC3455/LTC3455-1.

### Startup Issues in USB Low Power Mode When No Battery Is Present

For applications that must operate in USB low power mode when no battery is present, careful attention must be given to how the  $V_{MAX}$  pin and the output of the two switching regulators are loaded, especially during startup. Keep in mind that when the LTC3455/LTC3455-1 are USB

powered and the battery is not present, absence of the battery means that there is no reservoir if the system needs more power than the USB port can supply. Since the USB can only provide 100mA maximum current in low power mode, this gives, at best, only 500mW ( $5V \cdot 100mA$ ) of power available to get everything up and running. With a low USB voltage and a low USB current limit, less than 300mW may be available to start up the device. For some applications (if the outputs are too heavily loaded), this is simply not enough power to start up the system. If the  $V_{MAX}$  pin or the switching regulator outputs are loaded too heavily, the LTC3455/LTC3455-1 will be unable to regulate the outputs (due to insufficient input power), and an internal protection circuit will turn off the part after 200ms. This protection feature is discussed in detail in the section entitled “Low or Bad Battery Protection (200ms Timeout)”. Once this protection circuit is tripped, USB power must be removed and reapplied to restart the part.

Several steps can be taken to help lighten the total system load which will help greatly when the LTC3455/LTC3455-1 must start up in USB low power mode with no battery present.

1. Minimize the load currents on the  $V_{MAX}$  pin by delaying the turn on of all devices that are powered from  $V_{MAX}$  until after USB high power mode is available.
2. Minimize the load current on the output of Switcher 1 since Switcher 1 turns on automatically whenever USB power is available.
3. Delay the turn-on of Switcher 2 until after USB high power mode is available.

For some applications, USB high power mode should be selected during startup (at least briefly) to allow the LTC3455/LTC3455-1 to turn on properly. Startup in USB high power mode is typically not a problem, as more than 2W of power is available from the USB port in this mode.

## APPLICATIONS INFORMATION

### Handling Large Transient Loads when USB Powered

Many portable devices have nominal loads that can easily be supported by the USB supply, but they have brief transient loads that can exceed the maximum available USB power. The LTC3455/LTC3455-1 are designed to handle these overloads while drawing as much power as possible from the USB port. If the USB bus is providing power but the LTC3455/LTC3455-1 (or any other devices connected to the  $V_{MAX}$  pin) need more total power than the USB bus can supply, the battery charger turns off completely and the USB power controller becomes a 500mA (or 100mA) current source and the  $V_{MAX}$  voltage begins to decrease. At this point, the capacitance connected to the  $V_{MAX}$  pin provides the additional current needed by the system. As long as the USB pin stays above 3.9V, the USB bus will continue to provide as much current as possible. Once the  $V_{MAX}$  pin drops just below the  $V_{BAT}$  voltage, the battery will provide the additional current needed. This operation allows the LTC3455/LTC3455-1 to withstand load transients that briefly demand more power than can be provided by the USB bus.

The oscilloscope photographs in Figure 1 show how the LTC3455/LTC3455-1 handle load transients when USB powered. The top photo shows a brief transient load that turns off the charger but does not dip the  $V_{MAX}$  voltage. The bottom photo shows a prolonged transient condition that turns off the charger and completely dips the  $V_{MAX}$  voltage to the point where the battery must provide current. For both cases, normal operation resumes as soon as the transient passes.

Extra capacitance can be connected to the  $V_{MAX}$  pin to act as a reservoir to help support large transient currents. For most systems this is not necessary, as the LTC3455/LTC3455-1 cleanly handle heavy transients. For some designs, however, it may be desirable to use a larger capacitor connected to  $V_{MAX}$  to act as a larger reservoir. Up to 50 $\mu$ F of ceramic capacitance may be connected to the  $V_{MAX}$  pin without difficulty. More than 50 $\mu$ F requires using a capacitor with some ESR or adding some resistance in series with some of the ceramic capacitance. This is necessary to ensure loop stability in the battery charger loop when under USB power.

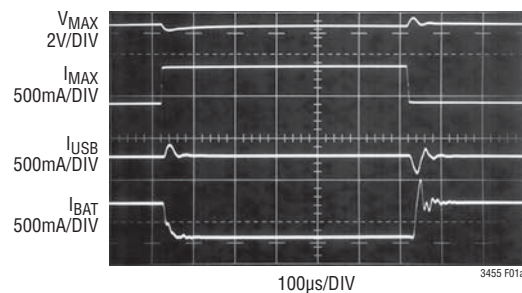

USB Maximum Current Condition

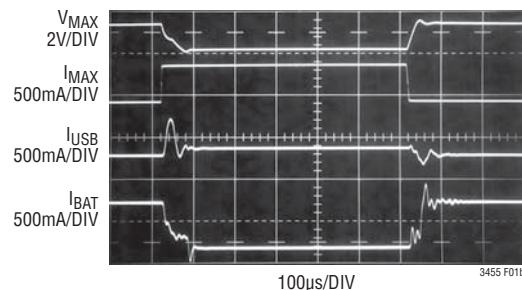

USB Heavy Over-Current Condition

Figure 1. Handling Load Transients when USB Powered

## APPLICATIONS INFORMATION

### Using the $V_{MAX}$ Pin to Power Other Devices

The  $V_{MAX}$  pin can be used to provide power for other devices within the system. This pin is connected to the battery when no external power is available, and it is connected to either the USB bus or the wall adapter when either are available. This ensures that all devices powered from  $V_{MAX}$  will always draw power from the best available input power source.

The internal PMOS connecting  $V_{MAX}$  to the battery is current limited to 900mA at startup (to minimize in-rush current) and to 4A once  $V_{MAX}$  has risen close to the battery voltage. Because of the reduced startup current limit, the turn-on of other devices powered from  $V_{MAX}$  should always be delayed to minimize the current initially needed from the  $V_{MAX}$  pin. The best choice is to enable these devices from either switcher output, since the turn-on of both switchers is always delayed until the  $V_{MAX}$  pin has reached the  $V_{BAT}$  pin voltage. The  $V_{MAX}$  pin is discharged to ground when the LTC3455/LTC3455-1 are shut down, so that any device supplied by  $V_{MAX}$  will have its input grounded during shutdown. This ensures output disconnect for all supply voltages within the system.

### Startup and Shutdown when Battery-Powered

When only battery power is available, the LTC3455/LTC3455-1 turn on when either the  $\overline{ON}$  pin is pulled low or the PWRON pin is pulled high. Either of these pins will keep the device running, but typically the  $\overline{ON}$  and PWRON pins are used together to provide turn-on and turn-off using a single momentary-on push-button switch. Figure 2 shows the method for using a momentary-on pushbutton to turn the LTC3455/LTC3455-1 off and on.

When the momentary-on switch is first pressed, shorting the  $\overline{ON}$  pin to ground, PBSTAT goes low and the LTC3455/LTC3455-1 first bring up the  $V_{MAX}$  pin, then enables Switcher 1 to power the microcontroller. Once up and running, the microcontroller provides the PWRON signal to keep the LTC3455/LTC3455-1 turned on after the push-button is released. When the push-button is pressed again to turn off the device, the PBSTAT pin is pulled low to notify the microcontroller that the push-button has been pressed. The microcontroller prepares for shutdown then pulls the PWRON signal low. When the push-button is released, the  $\overline{ON}$  pin goes high and the LTC3455/LTC3455-1 turn off. The  $\overline{ON}$  and PWRON pins enable Switcher 1 (along with all the internal circuits needed for normal operation), and the ON2 pin enables Switcher 2. Switcher 2 can only operate when Switcher 1 is also enabled. The turn-on of both switchers is always delayed until the  $V_{MAX}$  pin has reached the  $V_{BAT}$  pin voltage.

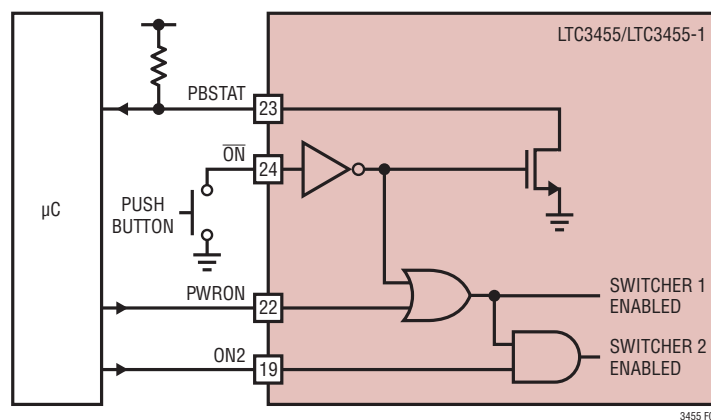

Figure 2. Momentary Push-Button Operation

## APPLICATIONS INFORMATION

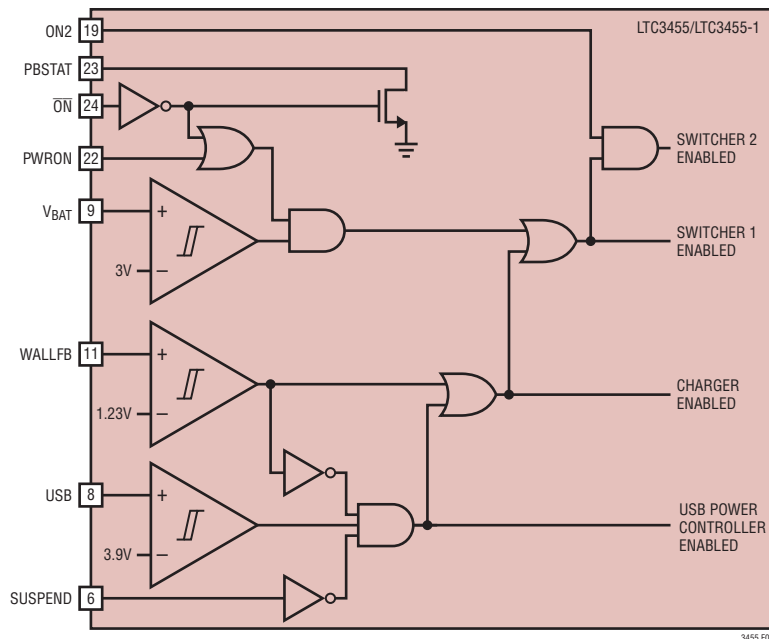

Figure 3. Turn-On Logic Diagram

## Startup and Shutdown When USB or Wall Powered

Whenever USB or wall power is present (as sensed by the USB and WALLFB pins), Switcher 1 and the battery charger will always be enabled. If the LTC3455/LTC3455-1 are off and external power is applied, both the charger and Switcher 1 will start independent of the state of the  $\overline{\text{ON}}$  and PWRON pins. This provides maximum battery run-time by always allowing the battery to charge whenever external power is available, and ensures that the microcontroller is always alive when external power is available (this is important for designs that utilize coulomb-counting or other battery monitoring techniques). Switcher 2 starts only if ON2 is also pulled high. Figure 3 shows the turn-on logic diagram for the LTC3455/LTC3455-1.

## Starting Switcher 2/Power Supply Sequencing

Switcher 2 can operate only when Switcher 1 is also enabled and in regulation. The ON2 pin can be driven by a logic signal for independent control of Switcher 2. If both outputs always operate together, tie the ON2 pin to the  $V_{\text{MAX}}$  pin. This will enable Switcher 2 after the output of Switcher 1 has reached 90% of its final value. This power-up delay ensures proper supply sequencing and reduces the peak battery current at startup. Figure 4 shows

the output sequencing when both switchers are enabled at startup with the ON2 pin tied to  $V_{\text{MAX}}$ . The turn-on of both switchers is always delayed until the  $V_{\text{MAX}}$  pin has reached the  $V_{\text{BAT}}$  pin voltage.

Reset Signal ( $\overline{\text{RST}}$ )

A 200ms reset signal (the  $\overline{\text{RST}}$  pin is pulled low) is provided for proper initialization of a microcontroller whenever the LTC3455/LTC3455-1 are first turned on, either by the  $\overline{\text{ON}}$  or PWR pins, or by the application of external power. The  $\overline{\text{RST}}$  signal is also pulled low whenever the entire LTC3455/LTC3455-1 are in shutdown, ensuring no false starts for the microcontroller as the output voltages are rising or collapsing.

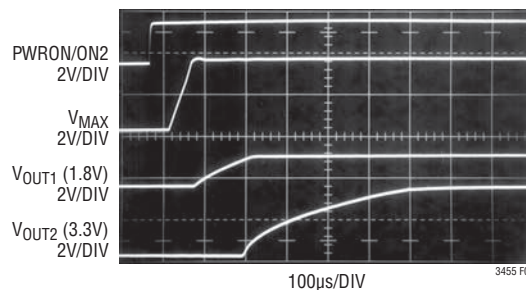

Figure 4. Sequencing for Switcher 1 and 2 Outputs

## APPLICATIONS INFORMATION

### Low or Bad Battery Protection (200ms Timeout)

The 200ms reset timer is also used to prevent starting the LTC3455/LTC3455-1 when there is insufficient external power or insufficient battery voltage to regulate the outputs. When first turned on, the internal 200ms timer starts. If only Switcher 1 is enabled (ON2 is low) and its output does not reach 90% of its final value within 200ms, Switcher 1 is shut down even if the  $\overline{\text{ON}}$  pin is held low or if the PWRON pin is held high (the  $V_{\text{MAX}}$  pin will remain on as long as  $\overline{\text{ON}}$  is low or PWRON is high). This automatic shutdown feature prevents possible damage to a defective or overdischarged Li-Ion battery. If ON2 is tied to  $V_{\text{MAX}}$  so that Switcher 2 is also turned on at startup, then both outputs must reach 90% of their final values within 200ms. Once the output(s) are in regulation, the timer is reset for a full 200ms.

### Schottky Diode Selection/WALLFB Resistor Selection

When a 5V wall adapter is used, power is provided to the  $V_{\text{MAX}}$  pin through a Schottky diode. The most important specification in picking this diode is its reverse leakage current. When the LTC3455/LTC3455-1 are turned on but wall power is not present, the Schottky will leak current to ground through the WALLFB resistor divider (see Figure 5). This leakage current should be minimized (by picking an appropriate low-leakage Schottky diode) as it can dramatically reduce Burst Mode efficiency at light loads. In addition, a high leakage current can also false trip the WALLFB pin and turn on the LTC3455/LTC3455-1 even if wall power is not available. To help prevent this false turn-on, use the WALLFB resistor values shown in Figure 5.

The diode forward voltage drop should be around 500mV or less at its maximum rated current to allow charging even when the wall adapter voltage is lower than normal. Some manufacturers have recently introduced Schottky diodes optimized for a very low forward drop, but their reverse leakage currents can be more than 100 $\mu$ A at room temperature, and over 1mA at high temperatures. These diodes are not recommended for use with the LTC3455/LTC3455-1, but if they are used operation at high temperature should be checked thoroughly to avoid problems due to excessive diode leakage current.

Three good diode choices are the MBRM110E (1A, 10V), MBR120ESF (1A, 20V), and the MBRA210E (2A, 10V). All are available in very small packages from ON Semiconductor ([www.onsemi.com](http://www.onsemi.com)), have reverse leakage currents under 1 $\mu$ A at room temperature, and have forward drops of around 500mV at their maximum rated current (1A or 2A).

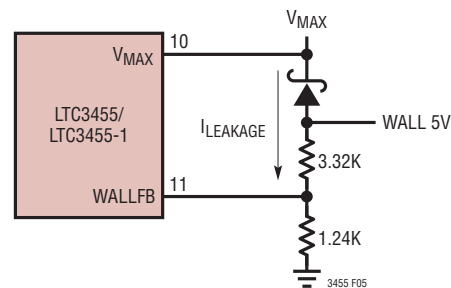

Figure 5. Schottky Leakage Current Path

### Switching Regulator General Information

The LTC3455/LTC3455-1 contain two 1.5MHz constant-frequency current mode switching regulators that operate with efficiencies up to 96%. Switcher 1 provides up to 400mA at 1.5V/1.8V (to power a microcontroller core), and Switcher 2 provides up to 500mA at 3V/3.3V (to power microcontroller I/O, memory and other logic circuitry). Both converters support 100% duty cycle operation (low dropout mode) when the input voltage drops very close to the output voltage, and both are capable of operating in Burst Mode operation for highest efficiencies at light loads (Burst Mode operation is pin selectable). Switcher 2 has independent ON/OFF control, but operates only when Switcher 1 is also enabled and in regulation. If both are enabled at power-up, Switcher 2 is allowed to turn on only after Switcher 1 has reached 90% of its final value. This power-up delay ensures proper supply sequencing and reduces the peak battery current at startup. If the output of Switcher 1 drops to below 85% of its programmed output voltage, Switcher 2 will turn off. This ensures that any problems with the core supply will shut down the rest of the system.

## APPLICATIONS INFORMATION

### Switching Regulator Inductor Selection

Many different sizes and shapes of inductors are available from numerous manufacturers. Choosing the right inductor from such a large selection of devices can be overwhelming, but following a few basic guidelines will make the selection process much simpler. To maximize efficiency, choose an inductor with a low DC resistance. Keep in mind that most inductors that are very thin or have a very small volume typically have much higher core and DCR losses, and will not give the best efficiency.

Choose an inductor with a DC current rating at least 1.5 times larger than the maximum load current to ensure that the inductor does not saturate during normal operation. Table 1 shows several inductors that work well with the LTC3455/LTC3455-1. These inductors offer a good compromise in current rating, DCR and physical size. Consult each manufacturer for detailed information on their entire selection of inductors.

**Table 1. Recommended Inductors**

Inductor Type	L (μH)	Max IDC (A)	Max DCR (Ω)	Height (mm)	Manufacturer
DB318C	4.7 10	0.86 0.58	0.1 0.18	1.8 1.8	Toko (847)297-0070 www.toko.com
CLS4D09	4.7 10	0.75 0.5	0.19 0.37	1 1	Sumida (847)956-0666 www.sumida.com
CDRH3D16	4.7 10	0.9 0.55	0.11 0.21	1.8 1.8	Sumida
SD12	4.7 10	1.29 0.82	0.12 0.28	1.2 1.2	Cooper (561)752-5000 www.cooperet.com
ELT5KT	4.7 10	1 0.68	0.2 0.36	1.2 1.2	Panasonic (408)945-5660 www.panasonic.com

### Switching Regulator Output Capacitor Selection

Low ESR (equivalent series resistance) ceramic capacitors should be used at both switching regulator outputs. Only X5R or X7R ceramic capacitors should be used because they retain their capacitance over wider voltage and temperature ranges than other ceramic types. A 10μF output capacitor is sufficient for most applications. Table 2 shows a list of several ceramic capacitor manufacturers. Consult each manufacturer for detailed information on their entire selection of ceramic capacitors. Many manufacturers now offer very thin (<1mm tall) ceramic capacitors ideal for use in height-restricted designs.

**Table 2. Recommended Ceramic Capacitor Manufacturers**

Taiyo Yuden	(408) 573-4150	www.t-yuden.com
AVX	(803) 448-9411	www.avxcorp.com
Murata	(714) 852-2001	www.murata.com
TDK	(888) 835-6646	www.tdk.com

### V<sub>BAT</sub> Pin Capacitor Selection

For the V<sub>BAT</sub> pin, a 4.7μF to 10μF ceramic capacitor is the best choice. Only X5R or X7R type ceramic capacitors should be used.

### V<sub>MAX</sub> Pin Capacitor Selection

For the V<sub>MAX</sub> pin, a 10μF ceramic capacitor is the best choice. Only X5R or X7R type ceramic capacitors should be used. Do not use less than 10μF on this pin. For some designs it may be desirable to use a larger capacitor connected to V<sub>MAX</sub> to act as a reservoir when the LTC3455/LTC3455-1 are USB powered. Up to 50μF of ceramic capacitance may be connected to the V<sub>MAX</sub> pin without difficulty. More than 50μF requires using a capacitor with some ESR (like a Tantalum or OS-CON) or adding some resistance in series with some of the ceramic capacitance. This is necessary to ensure loop stability in the battery charger loop when under USB power.

## APPLICATIONS INFORMATION

### USB Pin and Wall Adapter Capacitor Selection

The USB and wall adapter inputs should be bypassed with a 4.7 $\mu$ F to 10 $\mu$ F capacitor. For some applications, the wall input can be bypassed locally with a lower value (down to 1 $\mu$ F), but only if other bulk capacitance is present. The USB pin should always have at least 4.7 $\mu$ F. Ceramic capacitors (only type X5R or X7R) are typically the best choice due to their small size and good surge current ratings, but care must be taken when they are used. When ceramic capacitors are used for input bypassing, a 1 $\Omega$  series resistor must be added to prevent overvoltage ringing that often occurs when these inputs are hot-plugged. A tantalum, OS-CON, or electrolytic capacitor can be used in place of the ceramic and resistor, as their higher ESR reduces the Q, thus reducing the voltage ringing.

### Protecting the USB Pin and Wall Adapter Input from Overvoltage Transients

Caution must be exercised when using ceramic capacitors to bypass the USB pin or the wall adapter inputs. High voltage transients can be generated when the USB or wall adapter is hot plugged. When power is supplied via the USB bus or wall adapter, the cable inductance along with the self resonant and high Q characteristics of ceramic capacitors can cause substantial ringing which can easily exceed the maximum voltage pin ratings and damage the LTC3455/LTC3455-1. Refer to Linear Technology Application Note 88, entitled “Ceramic Input Capacitors Can Cause Overvoltage Transients” for a detailed discussion of this problem. The long cable lengths of most wall adapters and USB cables makes them especially susceptible to this problem. To bypass the USB pin and the wall adapter input, add a 1 $\Omega$  resistor in series with a ceramic capacitor to lower the effective Q of the network and greatly reduce the ringing. A tantalum, OS-CON, or electrolytic capacitor can be used in place of the ceramic and resistor, as their higher ESR reduces the Q, thus reducing the voltage ringing.

The oscilloscope photograph in Figure 6 shows how serious the overvoltage transient can be for the USB and wall adapter inputs. For both traces, a 5V supply is hot-plugged using a three foot long cable. For the top trace, only a 4.7 $\mu$ F capacitor (without the recommended

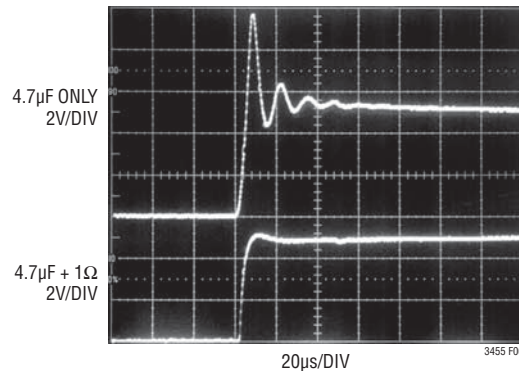

**Figure 6. Waveforms Resulting from Hot-Plugging a 5V Input Supply**

1 $\Omega$  series resistor) is used to locally bypass the input. This trace shows excessive ringing when the 5V cable is inserted, with the overvoltage spike reaching 10V; more than enough to damage the LTC3455/LTC3455-1. For the bottom trace, a 1 $\Omega$  resistor is added in series with the 4.7 $\mu$ F capacitor to locally bypass the 5V input. This trace shows the clean response resulting from the addition of the 1 $\Omega$  resistor.

Even with the additional 1 $\Omega$  resistor, bad design techniques and poor board layout can often make the overvoltage problem even worse. System designers often add extra inductance in series with input lines in an attempt to minimize the noise fed back to those inputs by the application. In reality, adding these extra inductances only makes the overvoltage transients worse. Since cable inductance is one of the fundamental causes of the excessive ringing, adding a series ferrite bead or inductor increases the effective cable inductance, making the problem even worse. For this reason, **do not** add additional inductance (ferrite beads or inductors) in series with the USB or wall adapter inputs. For the most robust solution, 6V transorbs or zener diodes may also be added to further protect the USB and wall adapter inputs. Two possible protection devices are the SM2T from STMicroelectronics and the EDZ series devices from ROHM.

**Always use an oscilloscope to check the voltage waveforms at the USB and V<sub>MAX</sub> pins during USB and wall adapter hot-plug events to ensure that overvoltage transients have been adequately removed.**

## APPLICATIONS INFORMATION

### Programming Switching Regulator Output Voltage

The output voltage for each switching regulator is programmed using a resistor divider from the output connected to the feedback pins (FB1 and FB2):

$$V_{OUT} = 0.8V \cdot \left(1 + \frac{R2}{R1}\right)$$

Typical values for R1 are in the range of 80k to 400k.

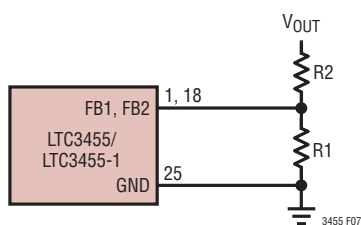

Figure 7. Setting the Output Voltage

### Burst Mode Operation

For highest efficiencies at light loads, both DC/DC converters are capable of operating in Burst Mode. In this mode, energy is delivered to the outputs in shorts bursts, which minimizes switching losses and quiescent-current losses. Output voltage ripple is slightly higher in this mode, but efficiency is greatly improved. As shown in Figure 8, the efficiency at low load currents increases significantly when Burst Mode operation is used.

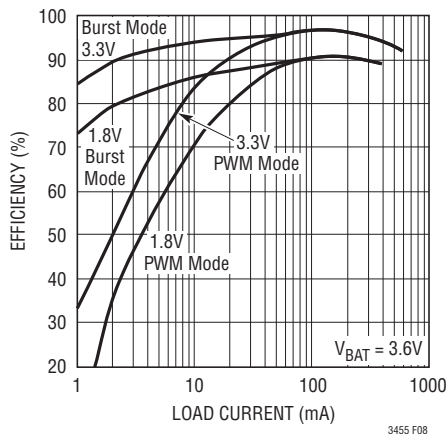

Figure 8. PWM and Burst Mode Efficiency

Tie the MODE pin to  $V_{MAX}$  to always allow automatic Burst Mode operation. Even when the MODE pin is high, the LTC3455/LTC3455-1 will only enter Burst Mode when the load current is low. For many noise-sensitive systems, Burst Mode operation might be undesirable at certain times (i.e. during a transmit or receive cycle of a wireless device), but highly desirable at others (i.e. when the device is in low-power standby mode). The MODE pin can be used to enable or disable Burst Mode operation at any time, offering both low-noise and low-power operation when they are needed the most. Burst Mode is disabled initially at startup (for the first 200ms) and also whenever external power is available, even if the MODE pin is pulled high.

Figure 9 shows the switching waveforms for switcher 1 (both PWM mode and Burst Mode Operation) with  $V_{IN} = 3.6V$ ,  $V_{OUT1} = 1.8V$ , and  $I_{OUT1} = 25mA$ .

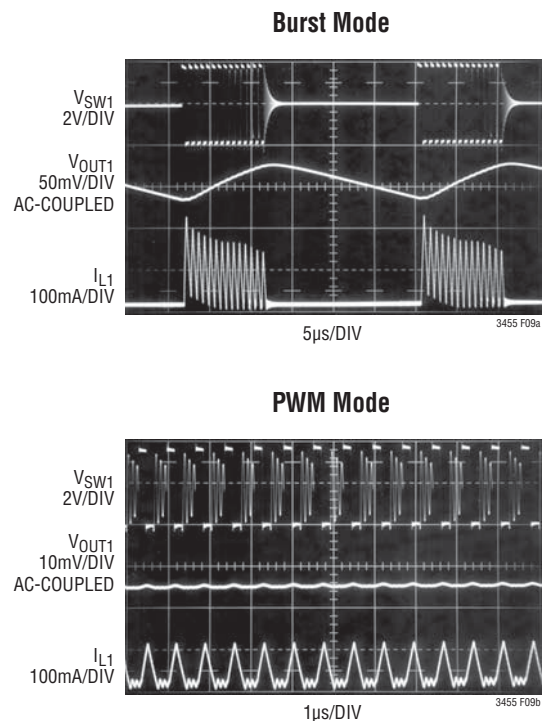

Figure 9. Burst Mode and PWM Mode Waveforms

## APPLICATIONS INFORMATION

Soft-start is accomplished by gradually increasing the peak inductor current for each switcher. This allows each output to rise slowly, helping minimize the battery in-rush current. Figure 10 shows the battery current during startup. A soft-start cycle occurs whenever each switcher first turns on, or after a fault condition has occurred (thermal shutdown or UVLO).

### In-Rush Current Limiting

When the LTC3455/LTC3455-1 are battery-powered, an internal  $0.15\Omega$  PMOS switch connects the battery ( $V_{BAT}$  pin) to the  $V_{MAX}$  pin to provide power for both switchers and other internal circuitry. This PMOS switch is turned off in shutdown, and the  $V_{MAX}$  pin discharges to ground, providing output disconnect for all outputs. At startup, this PMOS must first charge up any capacitance present on the  $V_{MAX}$  pin to the battery voltage. To minimize the in-rush current needed from the battery, the PMOS switch is current-limited to 900mA and both switchers are disabled while the  $V_{MAX}$  voltage is ramping up. Once  $V_{MAX}$  reaches the battery voltage, the PMOS current-limit increases to 4A and both switchers are allowed to turn on. Figure 10 shows the startup battery current for the LTC3455/LTC3455-1, which stays well-controlled while  $V_{MAX}$  is ramping up and while both switchers outputs are rising.

### Battery Charger General Information

The battery charger and Switcher 1 will always be enabled whenever USB or wall power is present (as sensed by the USB and WALLFB pins). This ensures that the battery can be charged and that the microcontroller is alive whenever

external power is available. For some applications, it may be undesirable for the charger to become active immediately when external power is applied. For such applications, an NMOS switch can be used to disconnect the  $R_{PROG}$  resistor and allow the PROG pin to float high, turning off the charger. In this manner, charging occurs only when allowed by the microcontroller.

The LTC3455/LTC3455-1 battery chargers are constant-current, constant-voltage chargers. In constant-current mode, the maximum charge current is set by a single external resistor. When the battery approaches the final float voltage, the charge current begins to decrease as the charger switches to constant-voltage mode. The charge cycle is terminated only by the charge timer.

### Charge and Recharge Cycles

When external power is first applied, a new charge cycle is always initiated. The battery will continue charging until the programmed charge time is reached. If the battery voltage is below 4.05V at the end of this cycle, the LTC3455/LTC3455-1 will start a new charge cycle. This action will continue until the battery voltage exceeds the 4.05V threshold. This operation is typically seen only when charging from USB power. Because the charge current can vary dramatically when the LTC3455/LTC3455-1 are USB powered, it takes considerably longer to charge a battery using the USB supply (as compared to a wall adapter). If the timer capacitor is chosen correctly, the battery should be fully charged on one cycle when wall power is available.

If the battery is above the 4.05V threshold when a charge cycle has expired, charging will stop. At this point, a recharge cycle is initiated if any of the following occurs: The battery voltage drops below 4.05V, external power is removed and reapplied, the PROG pin is floated temporarily, or the SUSPEND pin is temporarily pulled high (if the LTC3455/LTC3455-1 are under USB power).

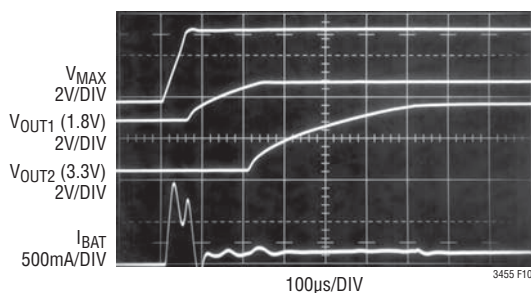

Figure 10. In-Rush Current at Start-Up

## APPLICATIONS INFORMATION

### Programming Charge Current

The maximum charge current is programmed using one external resistor connected between the PROG pin and GND (use the closest 1% resistor value):

$$R_{\text{PROG}} = 1000 \cdot 1.23\text{V} / I_{\text{BAT}}$$

If only USB power is used (no wall adapter), select the  $R_{\text{PROG}}$  value to be 2.49k $\Omega$  (or larger) to set the maximum charge current at 500mA. If a wall adapter is also used,  $I_{\text{CHARGE}}$  can be programmed up to 1A (with a 1.24k $\Omega$   $R_{\text{PROG}}$  value), and the USB power manager will automatically throttle back the charge current to below 500mA when under USB power.

### Monitoring Charge Current

The voltage on the PROG pin is an accurate indication of the battery charge current under all charging conditions.

$$I_{\text{BAT}} = 1000 \cdot V_{\text{PROG}} / R_{\text{PROG}}$$

Capacitance on the PROG pin should be minimized to ensure loop stability when in constant-current mode. Do not place a capacitor directly from the PROG pin to ground. Adding an external R-C network (see Figure 11) allows the monitoring of average, rather than instantaneous, battery charge current. Average charge current is typically of more interest to the user, especially when the LTC3455/LTC3455-1 are USB powered, as the battery charge current varies significantly with normal load transients.

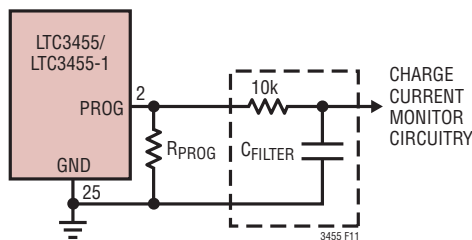

Figure 11. Monitoring Average Charge Current

### Programming the Battery Charger Timer

An external capacitor on the TIMER pin sets the total charge time. When this timer elapses the charge cycle terminates

and the  $\overline{\text{CHRG}}$  pin assumes a high impedance state. The total charge time is programmed as:

$$T_{\text{TIMER}} (\text{hours}) = C_{\text{TIMER}} \cdot (3 \text{ hours}) / (0.1\mu\text{F})$$

For most applications, a two to three hour timer will provide sufficient time to completely recharge the battery. But for some applications with larger capacity batteries, four to five hours of charging may be needed. A potential problem arises with setting such long timer periods (longer than 3 hours): If the battery is just below the recharge threshold (meaning it is almost fully charged) it will still be charged for the total timer period when external power is applied. This means that the battery will be continually charged at a very, very low charge current for the full four to five hours, even if the battery reaches the float voltage right away. This type of charging is undesirable for some battery applications, and can be avoided by choosing a shorter timer period (but not less than 1 hour). At the end of a charge cycle, the LTC3455 will measure the battery voltage to see if it is above the 4.05V recharge threshold. If it is not above 4.05V, a new charge cycle will begin, repeating until the battery voltage is above 4.05V. Even if the battery charges to just above the 4.05V threshold using this shorter timer method, more than 90% charge capacity should easily be reached (Note: The LTC3455-1 recharge threshold is 3.95V instead of 4.05V).

### Trickle Charge and Defective Battery Detection

If the battery voltage is below 2.85V at the beginning of the charge cycle, the charger goes into trickle charge mode, reducing the charge current to 10% of its programmed full-scale value. If the low battery voltage remains for one quarter of the programmed total charge time, the battery is assumed to be defective, the charge cycle is terminated, and the  $\overline{\text{CHRG}}$  pin goes to a high impedance state. This fault is cleared if any of the following occurs: The battery voltage rises above 2.85V, external power is removed and reapplied, the PROG pin is floated temporarily, or the SUSPEND pin is temporarily pulled high (if the LTC3455/LTC3455-1 are under USB power). The device will still operate normally from USB or wall power even if the charger has turned off due to a trickle-charge timeout.

## APPLICATIONS INFORMATION

### Battery Charger Thermal Limit

An internal thermal limit reduces the charge current if the die temperature attempts to rise above approximately 105°C. This protects the LTC3455/LTC3455-1 from excessive temperature, and allows the user to push the limits of the power handling capability of a given circuit board without risk of damaging the LTC3455/LTC3455-1. Another benefit of the thermal limit is that charge current can be set according to typical, not worst-case, ambient temperatures for a given application with the assurance that the charger will automatically reduce the current under worst-case conditions.

### CHRG Status Output

The  $\overline{\text{CHRG}}$  pin is pulled low with an internal N-channel MOSFET whenever the battery charger is enabled, and is forced into a high impedance state whenever it is disabled. This NMOS device is capable of driving an external LED. This pin does not provide any C/10 information.

### Special Charger Features while USB Powered

The LTC3455/LTC3455-1 have several special features that help make the most of the power available from the USB power supply. The internal USB power controller automatically throttles back the battery charge current to help keep the total system current under the strict 500mA/100mA USB limit. The graph in Figure 12 shows how charge current,  $I_{\text{BAT}}$ , decreases as the current needed for the rest of the system increases (both switchers and all other external devices pull current from the  $V_{\text{MAX}}$  pin). The total USB current,  $I_{\text{USB}}$ , always stays below 500mA.

As the USB voltage drops below 4.5V, the charge current gradually reduces (and eventually shuts off around 4V). This helps prevent “chattering” and stability problems when using long, resistive USB cables. Figure 13 shows this reduction in charge current.

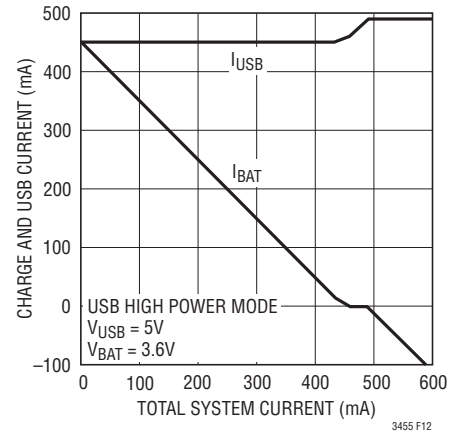

Figure 12. Charge Current vs Total System Current

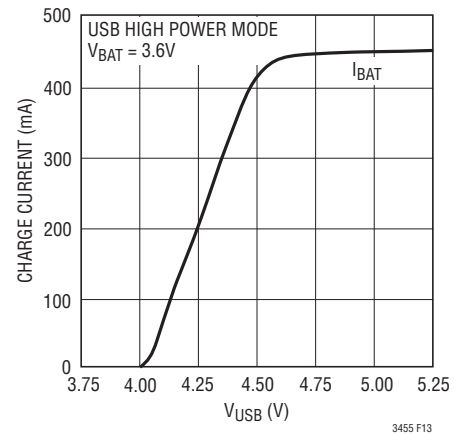

Figure 13. Charge Current vs USB Voltage

Because the charge current can vary dramatically when the LTC3455/LTC3455-1 are USB powered, battery charging can take considerably longer using the USB supply (as compared to a wall adapter).

### Constant-Current-Only Charger/Disabling the Charger Timer

To use the charger in a constant-current-only mode, connect the  $\text{TIMER}$  pin to  $V_{\text{MAX}}$  to disable the timer, voltage amplifier, and trickle charge function. To disable only the timer function and leave all others intact, connect the  $\text{TIMER}$

## APPLICATIONS INFORMATION

pin to GND. Since the charge cycle is terminated only by the charge timer, external charge termination is required when using either of these methods. Use an external NMOS to float the PROG pin and disable charging.

Constant-current-only mode is a good choice for systems that are always powered by a USB supply or wall adapter, and the charger can be used to charge a super-cap or backup battery. Disabling the voltage amplifier allows the super-cap/backup battery to charge up fully to the available USB or wall adapter voltage.

### Hot Swap Output

A current limited Hot Swap output is provided for powering memory cards or other external devices that can be hot-plugged into the system. Typically connected to the 3.3V supply, this output provides isolation to prevent the external device from disturbing the 3.3V supply when inserted. The Hot Swap output can only operate when the LTC3455/LTC3455-1 are on, and is enabled using the HSON pin. If this hot-plugging protection is not needed, this output can be used as a load switch for other devices within the system. The HSO pin is discharged to ground when the LTC3455/LTC3455-1 are shut down.

### Gain Block

The LTC3455/LTC3455-1 contain a gain block (pins AI and AO) that can be used as either a low-battery indicator, or as an LDO with the addition of an external PNP. Both circuits are shown in Figure 14. The LDO is convenient for applications needing a third output (possibly a low current 2.5V or a quiet 3V supply). The AO pin can sink around 1mA, which typically limits the LDO current to 100mA or less (due to the current gain of the PNP). An external PMOS can be used for the LDO, but a much larger output capacitor is needed to ensure stability at light loads.

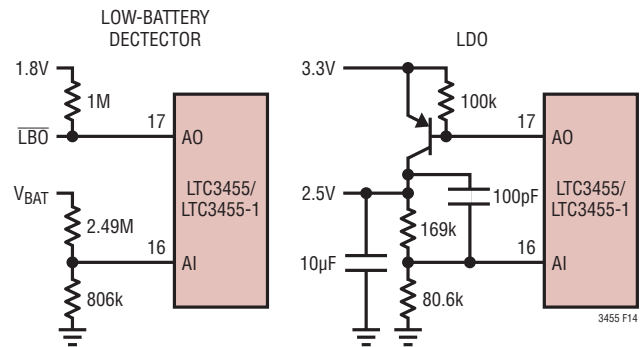

Figure 14. Low-Battery Detector and LDO Using the Gain Block

The gain block is alive whenever switcher 1 is enabled, and is turned off during shutdown to minimize battery drain. This means that the low-battery detector will not report a low-battery condition until the LTC3455/LTC3455-1 are turned on. This is not a problem for most applications since the LTC3455/LTC3455-1 usually power the microcontroller and all other intelligence in the system.

### PCB Layout Considerations

As with all DC/DC converters, careful attention must be paid to the printed circuit board (PCB) layout and component placement. The  $V_{BAT}$  capacitor,  $V_{MAX}$  capacitor, and both inductors must all be placed as close as possible to the LTC3455/LTC3455-1. These components, along with both DC/DC converter output capacitors, should be placed on the same side of the circuit board as the LTC3455/LTC3455-1, with their connections made on that top layer. Place a local, unbroken ground plane below these components that is tied to the Exposed Pad of the LTC3455/LTC3455-1. The Exposed Pad (pin 25) must be soldered to the PCB (to system ground) for proper operation. Figure 15 shows the recommended placement for the power sections of the LTC3455/LTC3455-1.

## APPLICATIONS INFORMATION

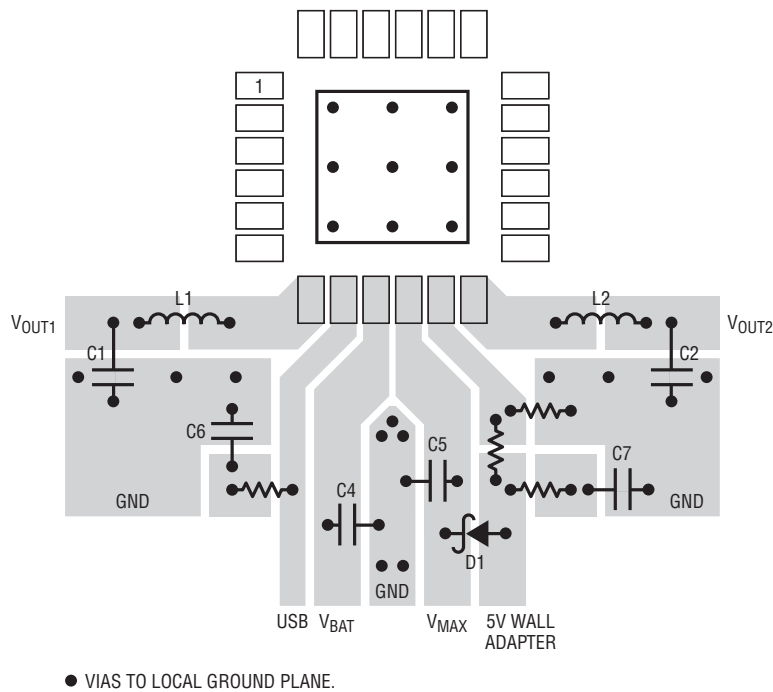

**Figure 15. Recommended Board Layout and Component Placement for Power Sections of LTC3455/LTC3455-1 (Refer to Schematic on Back Page)**

### Standalone USB Power Supply with Temporary Backup Power

Although designed primarily for Li-Ion powered portable applications, the LTC3455/LTC3455-1 are also good choices for systems that are always powered by a USB supply or wall adapter. The battery charger can then be used to charge up a large capacitor or backup battery, which briefly provides power to the system after the external power has been removed. This gives the microcontroller enough time to follow proper shutdown procedures when the main power source is abruptly removed. Figure 14 shows a standalone power supply for USB high power applications (500mA maximum USB current) using the LTC3455/LTC3455-1. The total system power should be kept below 1.8W to ensure clean operation even under worst-case USB conditions. With the resistor values

shown, the low-battery indicator (AI and AO pins) triggers when the  $V_{MAX}$  pin voltage drops to 4V, notifying the microcontroller of an impending dropout condition. The 1M $\Omega$  resistor connected between the AI and AO pins provides 150mV of hysteresis (the dropout indicator stays low until the  $V_{MAX}$  pin rises back above 4.15V). A 4700 $\mu$ F backup capacitor connected to the  $V_{BAT}$  pin briefly provides power to the system after the USB supply has been removed, and also helps support transient loads that slightly exceed the USB current limit. Connecting this large capacitance to the  $V_{BAT}$  pin has several advantages. It provides a large energy reservoir that is isolated from both the USB pin (the USB specification limits capacitance on the USB supply pin to 10 $\mu$ F or less) and the  $V_{MAX}$  pin (using a very large capacitance on this pin will delay the system turn-on), and it prevents large inrush currents by

**TYPICAL APPLICATIONS**

using the battery charger to slowly charge this capacitor (normally using such a large capacitor would result in very large inrush currents). With the TIMER pin tied to

$V_{MAX}$ , the battery charger operates in constant-current mode (the voltage-loop and timer function are disabled), so the 4700 $\mu$ F capacitor is always fully charged to the available USB voltage.

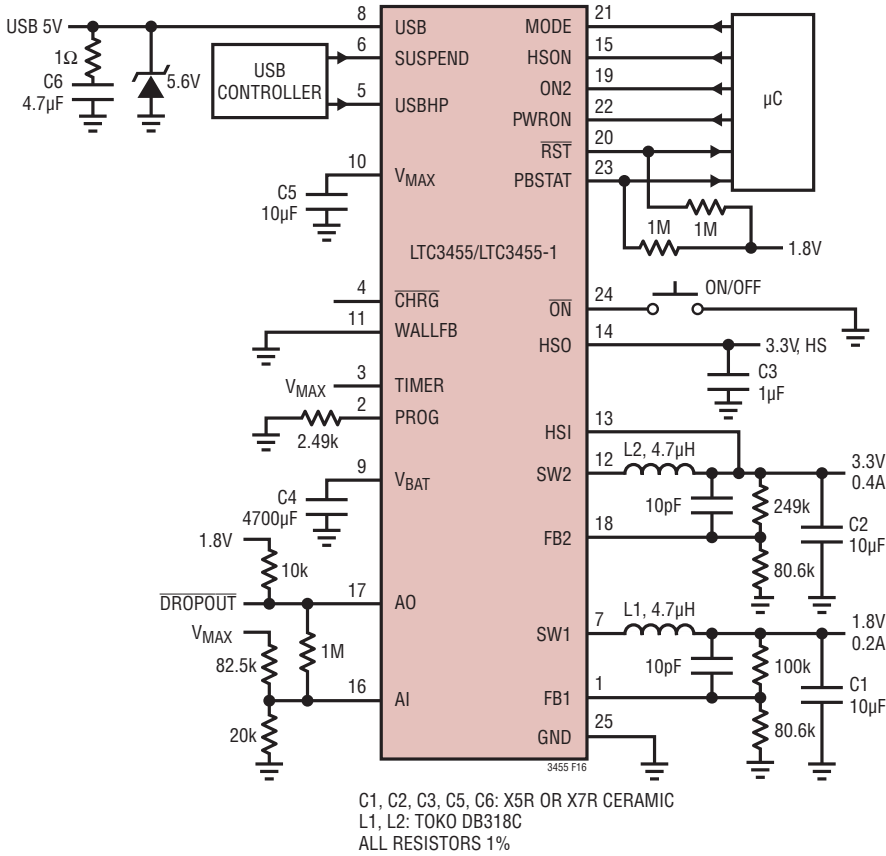

Figure 16. Standalone USB Power Supply with Temporary Backup Power

## TYPICAL APPLICATIONS

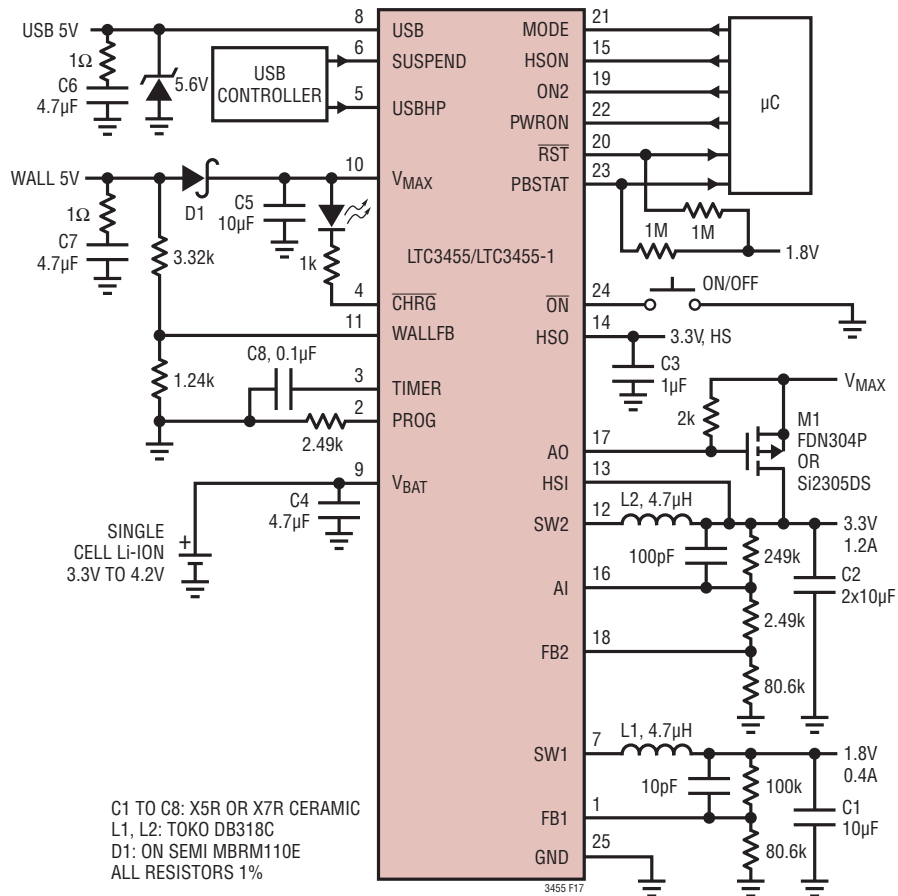

Figure 17. LTC3455/LTC3455-1 Application with 3.3V Output Current Increased to 1.2A

### Increasing 3.3V Output Current to 1.2A

With an internal current limit of 900mA, Switcher 2 typically provides a 3.3V, 600mA output. While this output current is sufficient for many portable devices, some applications need a 3.3V supply capable of providing more than 1A. Figure 17 shows how to implement a higher current 3.3V output using the LTC3455/LTC3455-1. By adding one tiny SOT23 PMOS and using the AI/AO amplifier as an LDO, the 3.3V output now provides 1.2A of output current. Switcher 2 is programmed for an output voltage of 3.3V, and the LDO is programmed for an output voltage of 3.2V (3% lower). As long as the load current is low enough for Switcher 2 to provide, the LDO is turned off completely. This circuit is ideal for applications that need the higher 3.3V output current for only a brief time. Switcher 2 will normally provide all of the output current, and the LDO will turn on briefly to provide the higher load currents.

When the load current exceeds what Switcher 2 can provide, the 3.3V output droops slightly and the LDO provides the additional current needed. Figure 18 shows the transient response when the 3.3V output current is stepped from 0.5A to 1.2A. More output capacitance can be added to improve the 3.3V transient response during these high current load steps.

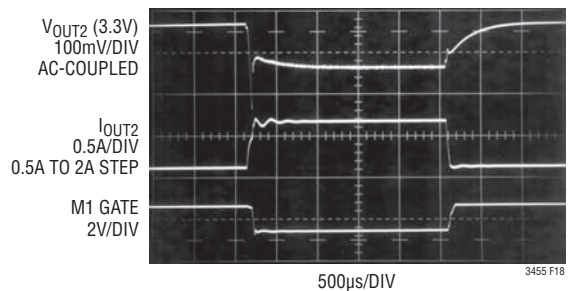
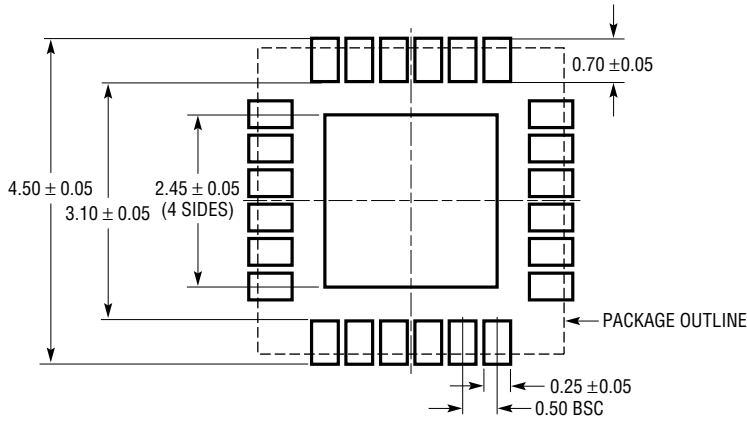

Figure 18. Load Current Step (0.5A to 1.2A) for 3.3V Output

# PACKAGE DESCRIPTION

**UF Package**  
**24-Lead Plastic QFN (4mm × 4mm)**  
 (Reference LTC DWG # 05-08-1697)



RECOMMENDED SOLDER PAD PITCH AND DIMENSIONS

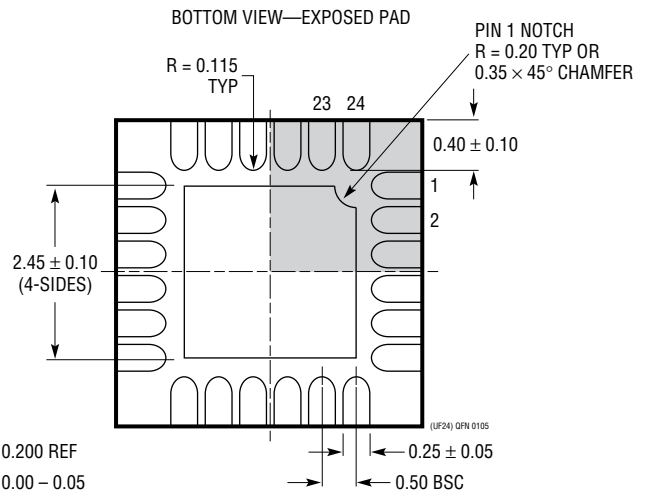
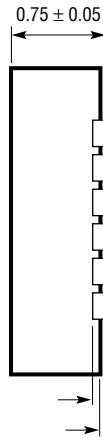
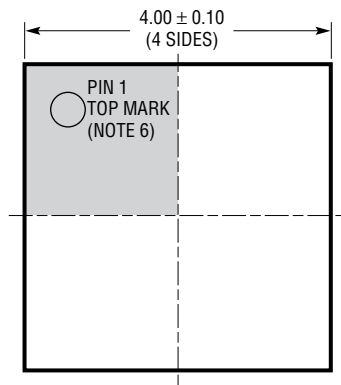

- NOTE:
1. DRAWING PROPOSED TO BE MADE A JEDEC PACKAGE OUTLINE MO-220 VARIATION (WGGD-X)—TO BE APPROVED
  2. DRAWING NOT TO SCALE
  3. ALL DIMENSIONS ARE IN MILLIMETERS
  4. DIMENSIONS OF EXPOSED PAD ON BOTTOM OF PACKAGE DO NOT INCLUDE MOLD FLASH. MOLD FLASH, IF PRESENT, SHALL NOT EXCEED 0.15mm ON ANY SIDE, IF PRESENT
  5. EXPOSED PAD SHALL BE SOLDER PLATED
  6. SHADED AREA IS ONLY A REFERENCE FOR PIN 1 LOCATION ON THE TOP AND BOTTOM OF PACKAGE

# LTC3455/LTC3455-1

## TYPICAL APPLICATION

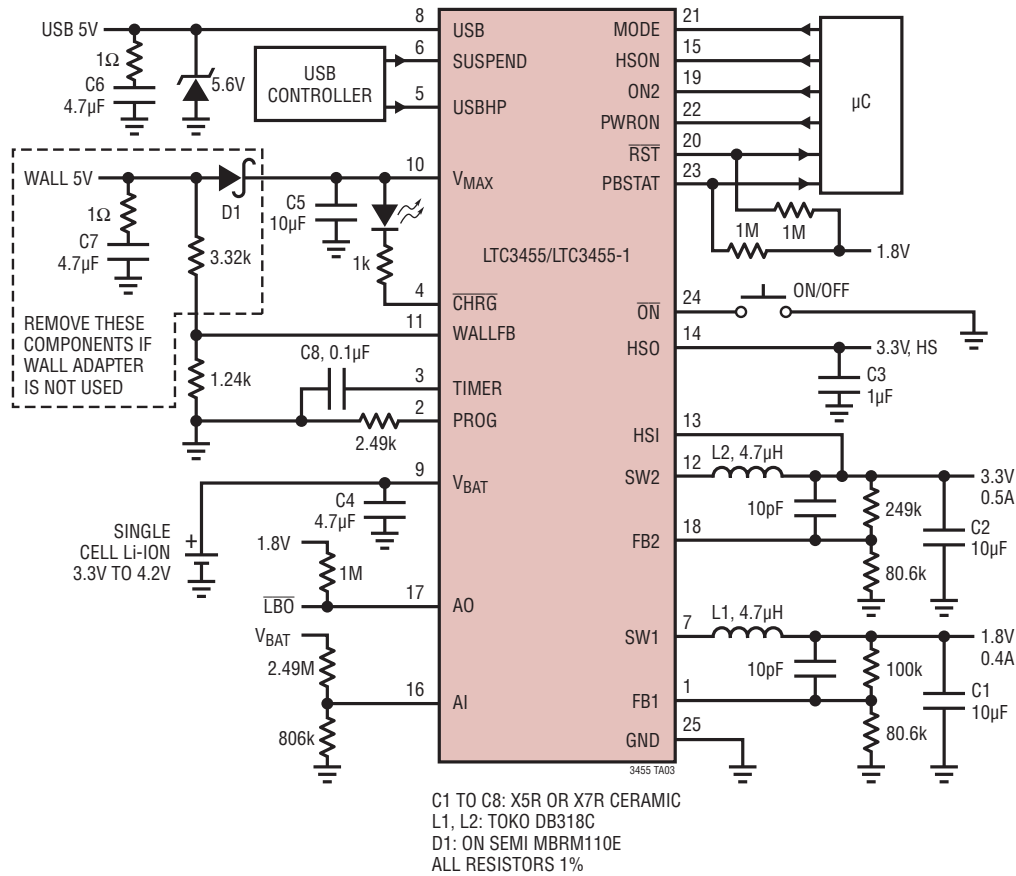

## RELATED PARTS

PART NUMBER	DESCRIPTION	COMMENTS
LT1616	500mA ( $I_{OUT}$ ), 1.4MHz, High Efficiency Step-Down DC/DC Converter	90% Efficiency, $V_{IN}$ : 3.6V to 25V, $V_{OUT(MIN)}$ = 1.25V, $I_Q$ = 1.9mA, $I_{SD}$ < 1µA, ThinSOT
LTC1879	1.2A ( $I_{OUT}$ ), 550kHz, Synchronous Step-Down DC/DC Converter	95% Efficiency, $V_{IN}$ : 2.7V to 10V, $V_{OUT(MIN)}$ = 0.8V, $I_Q$ = 15µA, $I_{SD}$ < 1µA, TSSOP16
LTC3405/LTC3405A	300mA ( $I_{OUT}$ ), 1.5MHz, Synchronous Step-Down DC/DC Converter	95% Efficiency, $V_{IN}$ : 2.7V to 6V, $V_{OUT(MIN)}$ = 0.8V, $I_Q$ = 20µA, $I_{SD}$ < 1µA, ThinSOT
LTC3406/LTC3406B	600mA ( $I_{OUT}$ ), 1.5MHz, Synchronous Step-Down DC/DC Converter	96% Efficiency, $V_{IN}$ : 2.5V to 5.5V, $V_{OUT(MIN)}$ = 0.6V, $I_Q$ = 20µA, $I_{SD}$ < 1µA, ThinSOT
LTC3407	Dual 600mA ( $I_{OUT}$ ), 1.5MHz, Synchronous Step-Down DC/DC Converter	96% Efficiency, $V_{IN}$ : 2.5V to 5.5V, $V_{OUT(MIN)}$ = 0.6V, $I_Q$ = 40µA, $I_{SD}$ < 1µA, MS10E
LTC3412	2.5A ( $I_{OUT}$ ), 4MHz, Synchronous Step-Down DC/DC Converter	95% Efficiency, $V_{IN}$ : 2.5V to 5.5V, $V_{OUT(MIN)}$ = 0.8V, $I_Q$ = 60µA, $I_{SD}$ < 1µA, TSSOP16E
LTC3414	4A ( $I_{OUT}$ ), 4MHz, Synchronous Step-Down DC/DC Converter	95% Efficiency, $V_{IN}$ : 2.25V to 5.5V, $V_{OUT(MIN)}$ = 0.8V, $I_Q$ = 64µA, $I_{SD}$ < 1µA, TSSOP16E
LTC3440/LTC3441	600mA/1A ( $I_{OUT}$ ), 2MHz/1MHz, Synchronous Buck-Boost DC/DC Converter	95% Efficiency, $V_{IN}$ : 2.5V to 5.5V, $V_{OUT(MIN)}$ = 2.5V, $I_Q$ = 25µA/50µA, $I_{SD}$ < 1µA, MS/DFN

## Looking for pricing, stock, or lifecycle information?

Click below to explore more details on WIN SOURCE:

- ⊖ [View LTC3455EUF-1#TRPBF on WIN SOURCE](#)
- ⊖ [Linear Technology Information](#)

## Optimize Your Supply Chain with WIN SOURCE Solutions

- ✓ Global Sourcing Solution
- ✓ Obsolete Management
- ✓ Cost Control Management
- ✓ Shortage Management
- ✓ Alternative Solution
- ✓ Excess Inventory Management