



**THE DATASHEET OF
FOD0708R2**



FOD0708 Single Channel CMOS Optocoupler, FOD0738 Dual Channel CMOS Optocoupler

Features

- +5V CMOS compatibility
- 15ns typical pulse width distortion
- 30ns max. pulse width distortion
- 40ns max. propagation delay skew
- High speed: 15 MBd
- 60ns max. propagation delay
- 10kV/ μ s minimum common mode rejection
- -40°C to 100°C temperature range
- UL approved (file #E90700)

Applications

- Line receivers
- Pulse transformer replacement
- Output interface to CMOS-LSTTL-TTL
- Wide bandwidth analog coupling

General Description

The FOD0708 and FOD0738 optocouplers consist of an AlGaAs LED optically coupled to a high speed trans-impedance amplifier and voltage comparator. These optocouplers utilize the latest CMOS IC technology to achieve outstanding performance with very low power consumption. The devices are housed in a compact 8-pin SOIC package for optimum mounting density.

Schematics

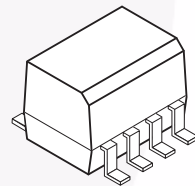
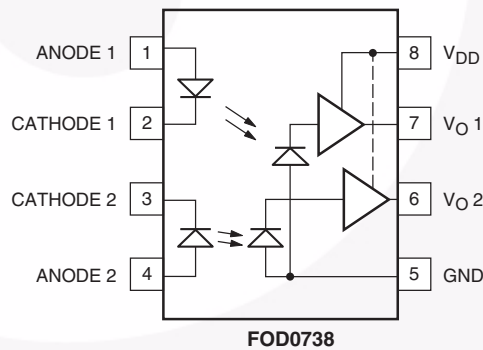
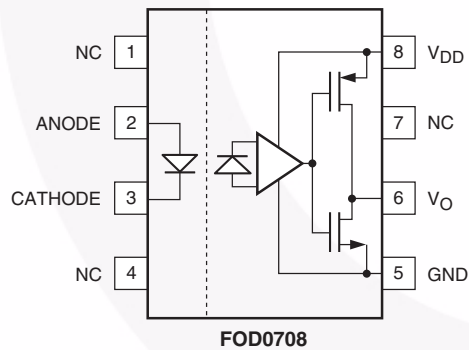

TRUTH TABLE

LED	V _O OUTPUT
OFF	H
ON	L

Note: A 0.1 μ F bypass capacitor must be connected between pins 5 and 8.

Absolute Maximum Ratings ($T_A = 25^\circ\text{C}$ unless otherwise specified)

Stresses exceeding the absolute maximum ratings may damage the device. The device may not function or be operable above the recommended operating conditions and stressing the parts to these levels is not recommended. In addition, extended exposure to stresses above the recommended operating conditions may affect device reliability. The absolute maximum ratings are stress ratings only.

Symbol	Parameter	Min.	Max.	Units
T_S	Storage Temperature	-40	+125	$^\circ\text{C}$
T_A	Ambient Operating Temperature	-40	+100	$^\circ\text{C}$
V_{DD}	Supply Voltages	0	6	Volts
V_O	Output Voltage	-0.5	$V_{DD} + 0.5$	Volts
I_O	Average Output Current		2	mA
I_F	Average Forward Input Current		20	mA
	Lead Solder Temperature	260 $^\circ\text{C}$ for 10 sec., 1.6 mm below seating plane		
	Solder Reflow Temperature Profile	See Solder Reflow Temperature Profile Section		
	LED Power Dissipation Single Channel Dual Channel	40mW (derate above 95 $^\circ\text{C}$, 1.4mW/ $^\circ\text{C}$) 40mW per channel (derate above 90 $^\circ\text{C}$, 1.2mW/ $^\circ\text{C}$)		
	Detector Power Dissipation Single Channel Dual Channel	85mW (derate above 75 $^\circ\text{C}$, 1.8mW/ $^\circ\text{C}$) 65mW per channel (derate above 90 $^\circ\text{C}$, 2.0mW/ $^\circ\text{C}$)		

Recommended Operating Conditions

The Recommended Operating Conditions table defines the conditions for actual device operation. Recommended operating conditions are specified to ensure optimal performance to the datasheet specifications. Fairchild does not recommend exceeding them or designing to absolute maximum ratings.

Symbol	Parameter	Min.	Max.	Units
T_A	Ambient Operating Temperature	-40	+100	$^\circ\text{C}$
V_{DD}	Supply Voltages	4.5	5.5	Volts
I_F	Input Current (ON)	10	16	mA

Electrical Characteristics ($T_A = -40^\circ\text{C}$ to $+100^\circ\text{C}$) and $4.5\text{ V} \leq V_{DD} \leq 5.5\text{ V}$

Symbol	Parameter	Test Conditions	Min.	Typ.*	Max.	Units	Fig.
V_F	Input Forward Voltage	$I_F = 12\text{mA}$	1.3	1.45	1.8	V	9
BV_R	Input Reverse Breakdown Voltage	$I_R = 10\mu\text{A}$	5			V	
V_{OH}	Logic High Output Voltage	$I_F = 0, I_O = -20\mu\text{A}$	4.0	5.0		V	
V_{OL}	Logic Low Output Voltage	$I_F = 12\text{mA}, I_O = 20\mu\text{A}$		0.01	0.1	V	
I_{TH}	Input Threshold Current (FOD0708) (FOD0738)	$I_{OL} = 20\mu\text{A}$		4.0 4.4	8.2 8.2	mA	1,5
I_{DDL}	Logic Low Output Supply Current (FOD0708) (FOD0738)	$I_F = 12\text{mA}$		3.4 6.9	14.0 18.0	mA	3,7
I_{DDH}	Logic High Output Supply Current (FOD0708) (FOD0738)	$I_F = 0$		3.7 7.5	11.0 15.0	mA	4,8

*All typicals at $T_A = 25^\circ\text{C}$ and $V_{DD} = 5\text{V}$ unless otherwise noted.

Switching Characteristics Over recommended temperature ($T_A = -40^\circ\text{C}$ to $+100^\circ\text{C}$) and $4.5\text{ V} \leq V_{DD} \leq 5.5\text{ V}$. All typical specifications are at $T_A = 25^\circ\text{C}$, $V_{DD} = +5\text{ V}$.

Symbol	Parameter	Test Conditions	Min.	Typ.*	Max.	Units
t_{PHL}	Propagation Delay Time to Logic Low Output	$I_F = 12\text{mA}$, $C_L = 15\text{pF}$ CMOS Signal Levels (Note 1) (Fig. 10)	20		60	ns
t_{PLH}	Propagation Delay Time to Logic High Output	$I_F = 12\text{mA}$, $C_L = 15\text{pF}$ CMOS Signal Levels, (Note 1) (Fig. 10)	FOD0708	13	60	ns
			FOD0738	11	60	
PW	Pulse Width		100			ns
PWD	Pulse Width Distortion	$I_F = 12\text{mA}$, $C_L = 15\text{pF}$, CMOS Signal Levels (Note 2)	0		30	ns
t_{PSK}	Propagation Delay Skew	$I_F = 12\text{mA}$, $C_L = 15\text{pF}$, CMOS Signal Levels (Note 3)			40	ns
t_R	Output Rise Time (10%–90%)	$I_F = 12\text{mA}$, $C_L = 15\text{pF}$, CMOS Signal Levels		12		ns
t_F	Output Fall Time (90%–10%)	$I_F = 12\text{mA}$, $C_L = 15\text{pF}$, CMOS Signal Levels		8		ns
CM_H	Common Mode Transient Immunity at Logic High Output	$V_{CM} = 1000\text{V}$, $T_A = 25^\circ\text{C}$, $I_F = 0\text{mA}$, (Note 4) (Fig. 11)	25	50		kV/ μs
CM_L	Common Mode Transient Immunity at Logic Low Output	$V_{CM} = 1000\text{V}$, $T_A = 25^\circ\text{C}$, $I_F = 12\text{mA}$, (Note 5) (Fig. 11)	25	50		kV/ μs

*All typicals at $T_A = 25^\circ\text{C}$ and $V_{DD} = 5\text{V}$ unless otherwise noted.

Isolation Characteristics ($T_A = -40^\circ\text{C}$ to $+100^\circ\text{C}$ Unless otherwise specified.)

Characteristics	Test Conditions	Symbol	Min	Typ.*	Max	Unit
Input-Output Insulation Leakage Current	Relative humidity = 45%, $T_A = 25^\circ\text{C}$, $t = 5\text{s}$, $V_{I-O} = 3000\text{ VDC}$ (Note 6)	I_{I-O}			1.0	μA
Withstand Insulation Test Voltage	$I_{I-O} \leq 10\mu\text{A}$, $R_H < 50\%$, $T_A = 25^\circ\text{C}$, $t = 1\text{ min.}$ (Note 6)	V_{ISO}	2500			V_{RMS}
Resistance (Input to Output)	$V_{I-O} = 500\text{V}$ (Note 6)	R_{I-O}		10^{12}		Ω
Capacitance (Input to Output)	$f = 1\text{MHz}$ (Note 6)	C_{I-O}		0.6		pF

*All typical values are at $V_{CC} = 5\text{ V}$, $T_A = 25^\circ\text{C}$

Notes:

- Propagation delay time, high to low (t_{PHL}), is measured from the 50% level on the rising edge of the input pulse to the 2.5V level of the falling edge of the output voltage signal. Propagation delay time, low to high (t_{PLH}), is measured from the 50% level on the falling edge of the input pulse to the 2.5V level of the rising edge of the output voltage signal.
- Pulse width distortion is defined as the absolute difference between the high to low and low to high propagation delay times, $|t_{PHL} - t_{PLH}|$.
- Propagation delay skew, t_{PSK} , is defined as the worst case difference in t_{PHL} or t_{PLH} between units within the recommended operating range of the device.
- CM_H – The maximum tolerated rate of rise of the common mode voltage to ensure the output will remain in the high state, (i.e., $V_{OUT} > 2.0\text{V}$) Measured in kilovolts per microsecond (kV/ μs).
- CM_L – The maximum tolerated rate of fall of the common mode voltage to ensure the output will remain in the low state, (i.e., $V_{OUT} < 0.8\text{V}$). Measured in kilovolts per microsecond (kV/ μs).
- Isolation voltage, V_{ISO} , is an internal device dielectric breakdown rating. For this test, pins 1,2,3,4 are common, and pins 5,6,7,8 are common.

Typical Performance Curves

Figure 1. FOD0708
Typical Input Threshold Current vs Ambient Temperature

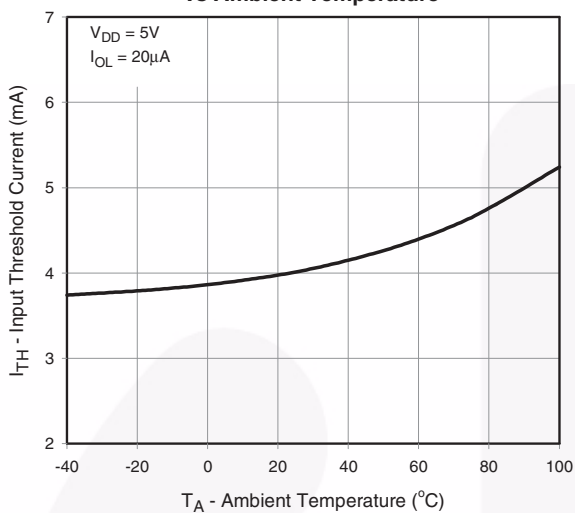

Figure 2. FOD0708
Typical Switching Speed vs Pulse Input Current

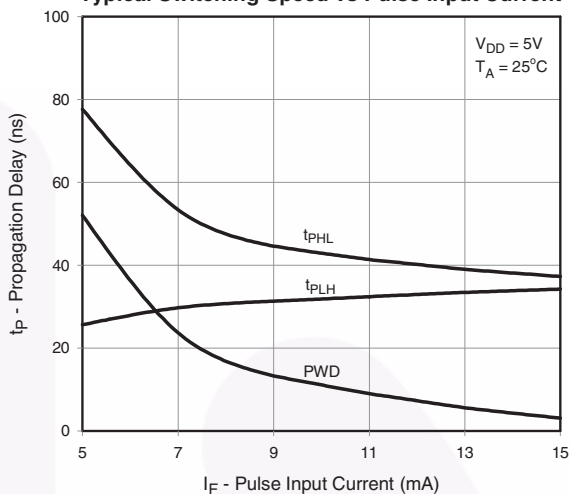

Figure 3. FOD0708
Typical Logic Low Output Supply Current vs Ambient Temperature

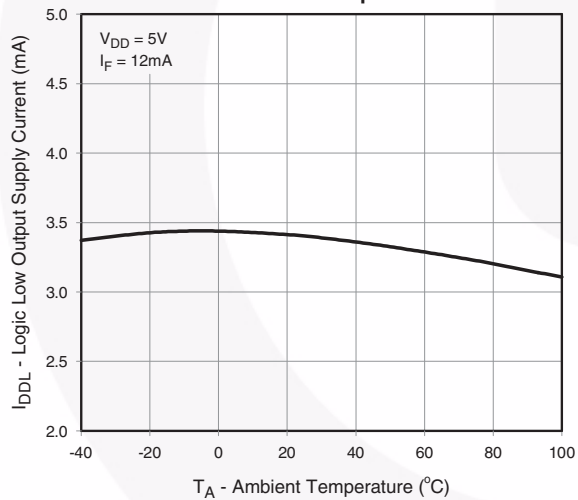
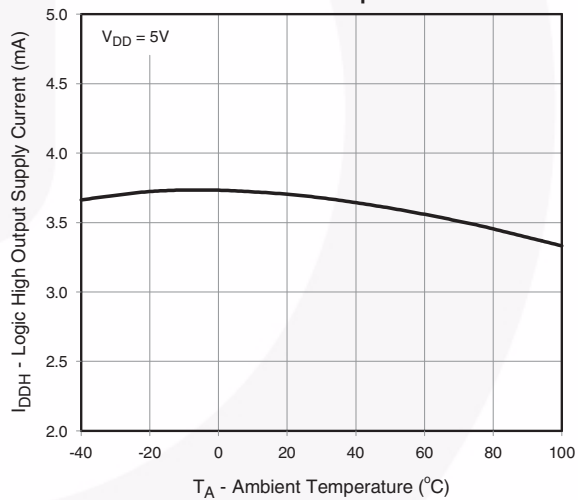

Figure 4. FOD0708
Typical Logic High Output Supply Current vs Ambient Temperature



Typical Performance Curves (Continued)

Figure 5. FOD0738
Typical Input Threshold Current vs Ambient Temperature

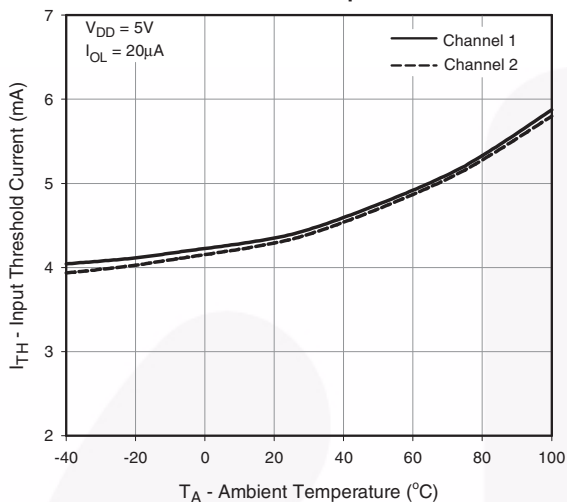

Figure 6. FOD0738
Typical Switching Speed vs Pulse Input Current

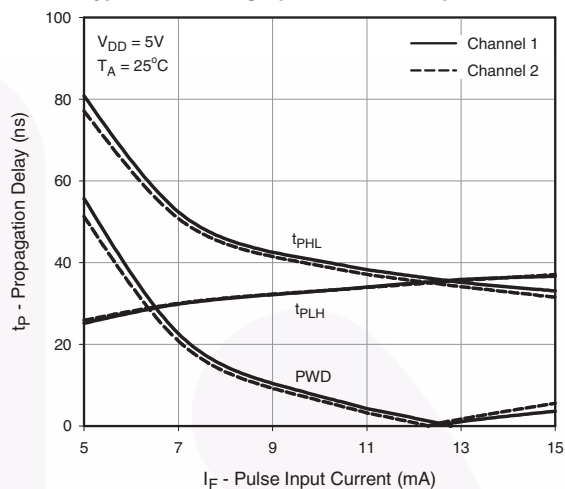

Figure 7. FOD0738
Typical Logic Low Output Supply Current vs Ambient Temperature

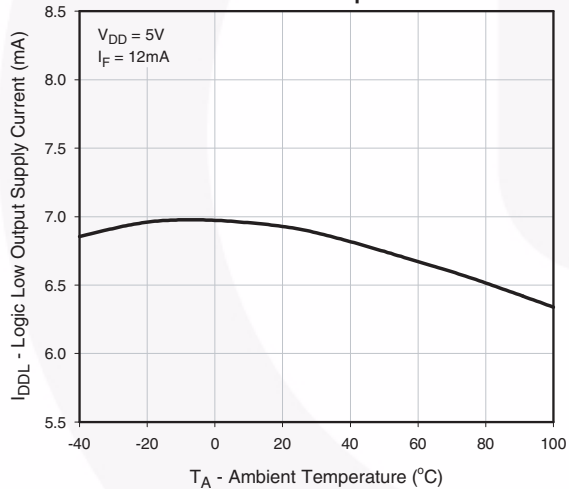
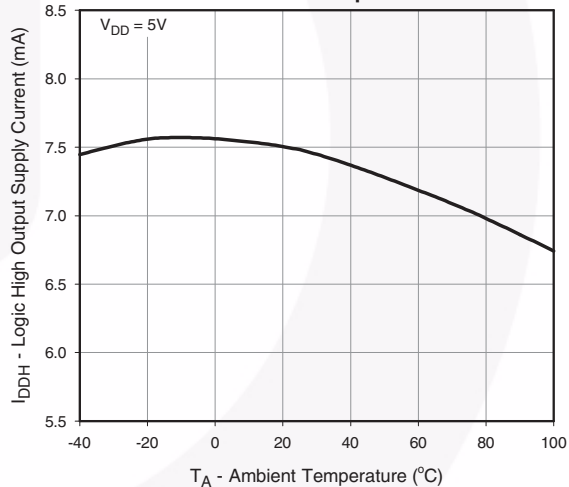
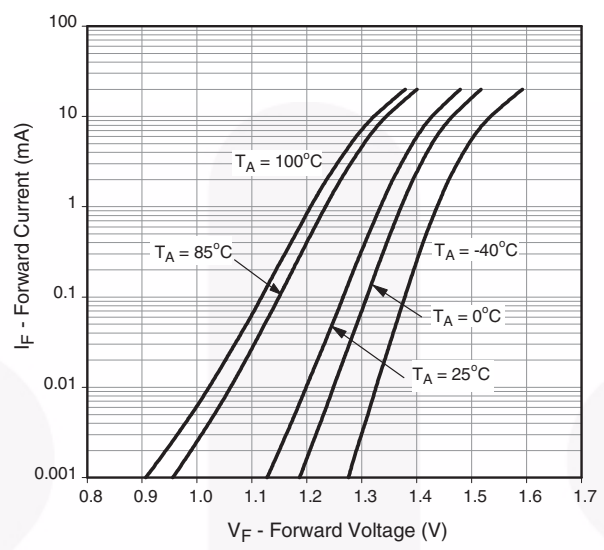

Figure 8. FOD0738
Typical Logic High Output Supply Current vs Ambient Temperature



Typical Performance Curves (Continued)

Figure 9. Input Forward Current vs. Forward Voltage



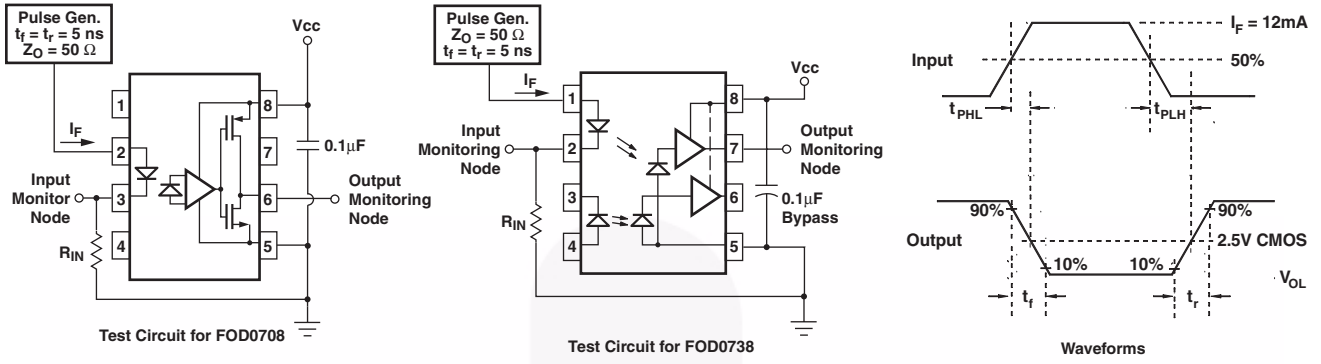

Fig. 10 Test Circuit and Waveforms for t_{PLH} , t_{PHL} , t_r and t_{rf} .

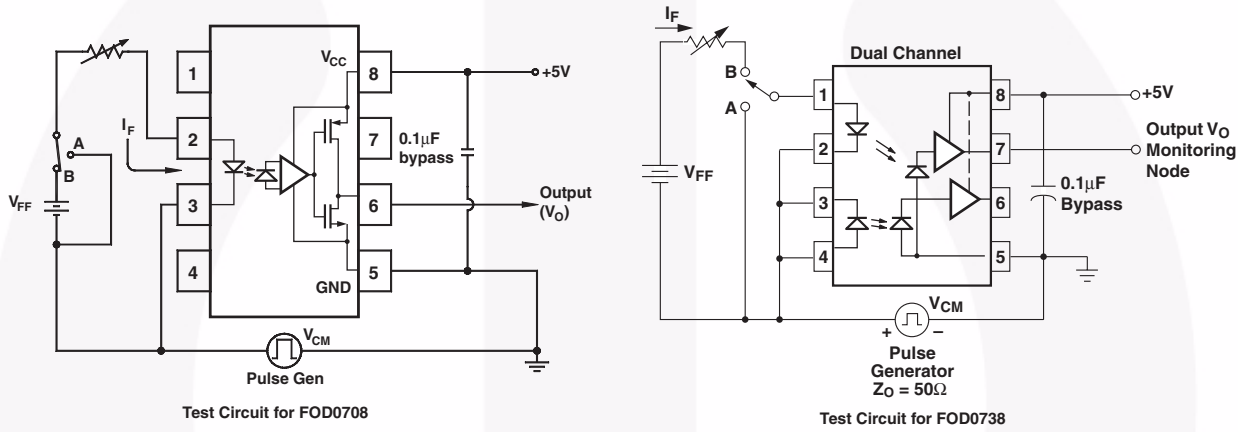
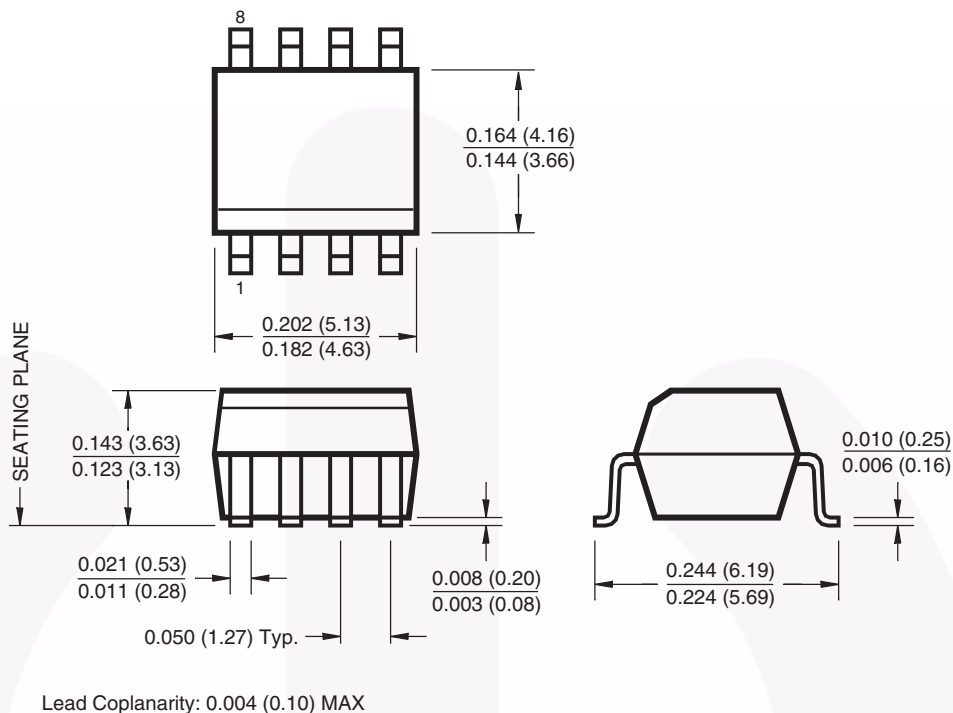

Fig. 11 Test Circuit Common Mode Transient Immunity (FOD0708 and FOD0738)

Package Dimensions

8-pin SOIC Surface Mount



Recommended Pad Layout

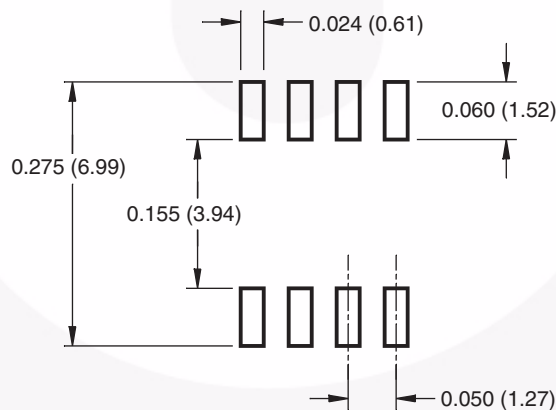

Dimensions in inches (mm).

Package drawings are provided as a service to customers considering Fairchild components. Drawings may change in any manner without notice. Please note the revision and/or date on the drawing and contact a Fairchild Semiconductor representative to verify or obtain the most recent revision. Package specifications do not expand the terms of Fairchild's worldwide terms and conditions, specifically the warranty therein, which covers Fairchild products.

Always visit Fairchild Semiconductor's online packaging area for the most recent package drawings:

<http://www.fairchildsemi.com/packaging/>

Ordering Information

Option	Order Entry Identifier	Description
No Suffix	FOD0708	Shipped in tubes (50 units per tube)
R2	FOD0708R2	Tape and Reel (2500 units per reel)

Marking Information

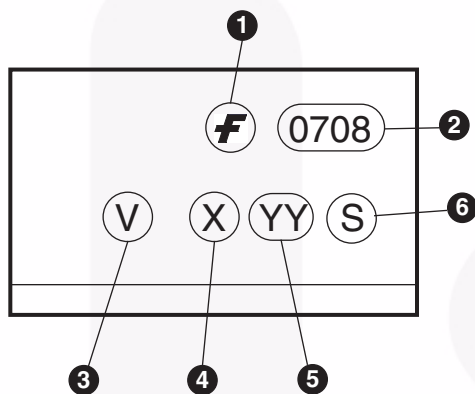

Definitions	
1	Fairchild logo
2	Device number
3	VDE mark (Note: Only appears on parts ordered with VDE option – See order entry table)
4	One digit year code, e.g., '5'
5	Two digit work week ranging from '01' to '53'
6	Assembly package code

Carrier Tape Specification

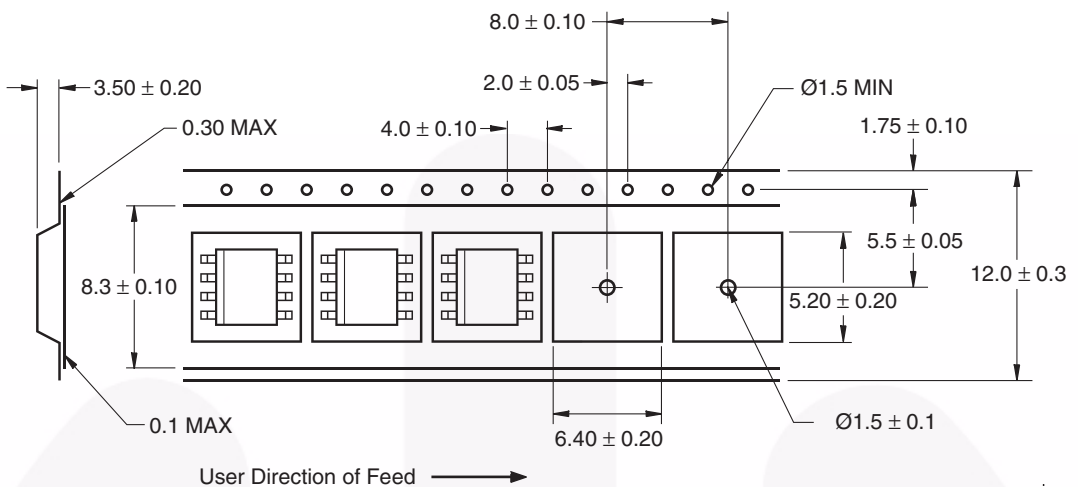

Dimensions in mm

Reflow Profile

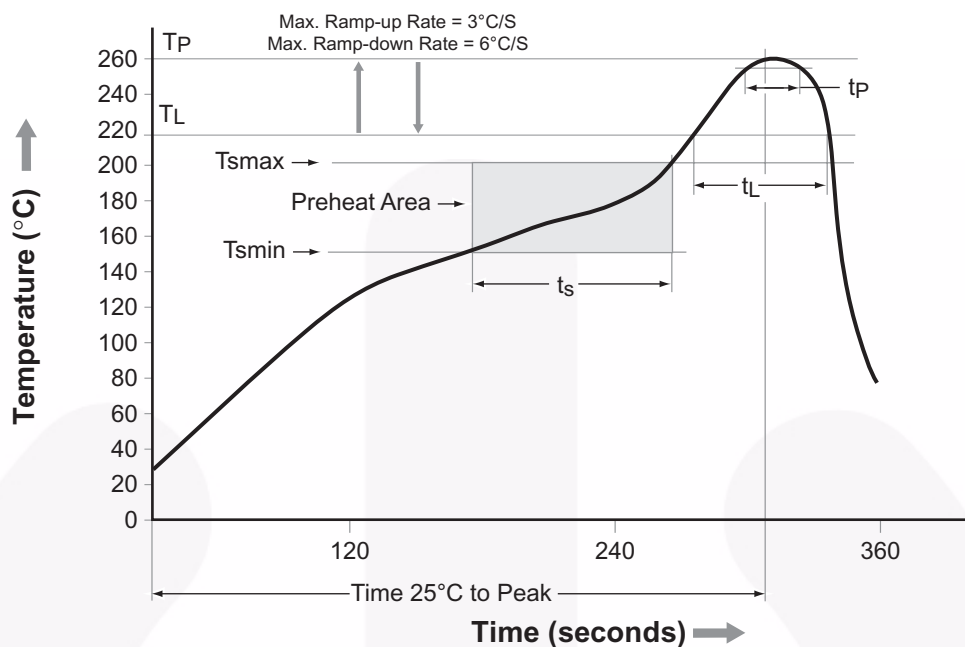



Profile Feature	Pb-Free Assembly Profile
Temperature Min. (Tsmín)	150°C
Temperature Max. (Tsmáx)	200°C
Time (ts) from (Tsmín to Tsmáx)	60–120 seconds
Ramp-up Rate (tL to tP)	3°C/second max.
Liquidous Temperature (TL)	217°C
Time (tL) Maintained Above (TL)	60–150 seconds
Peak Body Package Temperature	260°C +0°C / -5°C
Time (tp) within 5°C of 260°C	30 seconds
Ramp-down Rate (TP to TL)	6°C/second max.
Time 25°C to Peak Temperature	8 minutes max.



TRADEMARKS

The following includes registered and unregistered trademarks and service marks, owned by Fairchild Semiconductor and/or its global subsidiaries, and is not intended to be an exhaustive list of all such trademarks.

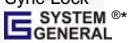
- | | | | |
|--|---|--|---|
| Auto-SPM™ | F-PFS™ | PowerTrench® | The Power Franchise® |
| Build it Now™ | FRFET® | PowerXS™ | the power franchise |
| CorePLUS™ | Global Power Resource™ | Programmable Active Droop™ | TinyBoost™ |
| CorePOWER™ | Green FPS™ | QFET® | TinyBuck™ |
| CROSSVOLT™ | Green FPS™ e-Series™ | QS™ | TinyLogic® |
| CTL™ | Gmax™ | Quiet Series™ | TINYOPTO™ |
| Current Transfer Logic™ | GTO™ | RapidConfigure™ | TinyPower™ |
| EcoSPARK® | IntelliMAX™ |  ™ | TinyPWM™ |
| EfficientMax™ | ISOPLANAR™ | Saving our world, 1mW/W/kW at a time™ | TinyWire™ |
| EZSWITCH™* | MegaBuck™ | SmartMax™ | TriFault Detect™ |
|  ™* | MICROCOUPLER™ | SMART START™ | TRUECURRENT™* |
|  ® | MicroFET™ | SPM® | µSerDes™ |
| Fairchild® | MicroPak™ | STEALTH™ |  ™ |
| Fairchild Semiconductor® | MillerDrive™ | SuperFET™ | UHC® |
| FACT Quiet Series™ | MotionMax™ | SuperSOT™-3 | Ultra FRFET™ |
| FACT® | Motion-SPM™ | SuperSOT™-6 | UniFET™ |
| FAST® | OPTOLOGIC® | SuperSOT™-8 | VCX™ |
| FAST® | OPTOPLANAR® | SupreMOS™ | VisualMax™ |
| FastvCore™ |  ™ | SyncFET™ | XS™ |
| FETBench™ | PDP SPM™ | Sync-Lock™ | |
| FlashWriter®* | Power-SPM™ |  ™* | |
| FPS™ | | | |

* Trademarks of System General Corporation, used under license by Fairchild Semiconductor.

DISCLAIMER

FAIRCHILD SEMICONDUCTOR RESERVES THE RIGHT TO MAKE CHANGES WITHOUT FURTHER NOTICE TO ANY PRODUCTS HEREIN TO IMPROVE RELIABILITY, FUNCTION, OR DESIGN. FAIRCHILD DOES NOT ASSUME ANY LIABILITY ARISING OUT OF THE APPLICATION OR USE OF ANY PRODUCT OR CIRCUIT DESCRIBED HEREIN; NEITHER DOES IT CONVEY ANY LICENSE UNDER ITS PATENT RIGHTS, NOR THE RIGHTS OF OTHERS. THESE SPECIFICATIONS DO NOT EXPAND THE TERMS OF FAIRCHILD'S WORLDWIDE TERMS AND CONDITIONS, SPECIFICALLY THE WARRANTY THEREIN, WHICH COVERS THESE PRODUCTS.

LIFE SUPPORT POLICY

FAIRCHILD'S PRODUCTS ARE NOT AUTHORIZED FOR USE AS CRITICAL COMPONENTS IN LIFE SUPPORT DEVICES OR SYSTEMS WITHOUT THE EXPRESS WRITTEN APPROVAL OF FAIRCHILD SEMICONDUCTOR CORPORATION.

As used herein:

1. Life support devices or systems are devices or systems which, (a) are intended for surgical implant into the body or (b) support or sustain life, and (c) whose failure to perform when properly used in accordance with instructions for use provided in the labeling, can be reasonably expected to result in a significant injury of the user.
2. A critical component in any component of a life support, device, or system whose failure to perform can be reasonably expected to cause the failure of the life support device or system, or to affect its safety or effectiveness.

ANTI-COUNTERFEITING POLICY

Fairchild Semiconductor Corporation's Anti-Counterfeiting Policy. Fairchild's Anti-Counterfeiting Policy is also stated on our external website, www.fairchildsemi.com, under Sales Support.

Counterfeiting of semiconductor parts is a growing problem in the industry. All manufacturers of semiconductor products are experiencing counterfeiting of their parts. Customers who inadvertently purchase counterfeit parts experience many problems such as loss of brand reputation, substandard performance, failed applications, and increased cost of production and manufacturing delays. Fairchild is taking strong measures to protect ourselves and our customers from the proliferation of counterfeit parts. Fairchild strongly encourages customers to purchase Fairchild parts either directly from Fairchild or from Authorized Fairchild Distributors who are listed by country on our web page cited above. Products customers buy either from Fairchild directly or from Authorized Fairchild Distributors are genuine parts, have full traceability, meet Fairchild's quality standards for handling and storage and provide access to Fairchild's full range of up-to-date technical and product information. Fairchild and our Authorized Distributors will stand behind all warranties and will appropriately address any warranty issues that may arise. Fairchild will not provide any warranty coverage or other assistance for parts bought from Unauthorized Sources. Fairchild is committed to combat this global problem and encourage our customers to do their part in stopping this practice by buying direct or from authorized distributors.

PRODUCT STATUS DEFINITIONS



Definition of Terms

Datasheet Identification	Product Status	Definition
Advance Information	Formative / In Design	Datasheet contains the design specifications for product development. Specifications may change in any manner without notice.
Preliminary	First Production	Datasheet contains preliminary data; supplementary data will be published at a later date. Fairchild Semiconductor reserves the right to make changes at any time without notice to improve design.
No Identification Needed	Full Production	Datasheet contains final specifications. Fairchild Semiconductor reserves the right to make changes at any time without notice to improve the design.
Obsolete	Not In Production	Datasheet contains specifications on a product that is discontinued by Fairchild Semiconductor. The datasheet is for reference information only.

Rev. 140

Looking for pricing, stock, or lifecycle information?

Click below to explore more details on WIN SOURCE:

-  [View FOD0708R2 on WIN SOURCE](#)
-  [Fairchild/ON Semiconductor Information](#)

Optimize Your Supply Chain with WIN SOURCE Solutions

-  Global Sourcing Solution
-  Obsolete Management
-  Cost Control Management
-  Shortage Management
-  Alternative Solution
-  Excess Inventory Management