



**THE DATASHEET OF  
LT1394IS8#PBF**



# 7ns, Low Power, Single Supply, Ground-Sensing Comparator

## FEATURES

- **UltraFast™: 7ns**
- **Low Power: 6mA**
- **Low Offset Voltage: 0.8mV**
- Operates Off Single 5V or Dual  $\pm 5V$  Supplies
- Input Common Mode Extends to Negative Supply
- No Minimum Input Slew Rate Requirement
- Complementary TTL Outputs
- Inputs Can Exceed Supplies without Phase Reversal
- Pin Compatible with LT1016, LT1116 and LT1671
- Output Latch Capability
- Available in 8-Lead MSOP and SO Packages

## APPLICATIONS

- High Speed A/D Converters
- Zero-Crossing Detectors
- Current Sense for Switching Regulators
- Extended Range V/F Converters
- Fast Pulse Height/Width Discriminators
- High Speed Triggers
- Line Receivers
- High Speed Sampling Circuits

LT, LTC and LT are registered trademarks of Linear Technology Corporation.  
 UltraFast is a trademark of Linear Technology Corporation.

## DESCRIPTION

The LT<sup>®</sup>1394 is an UltraFast (7ns) comparator with complementary outputs and latch. The input common mode range extends from 1.5V below the positive supply down to the negative supply rail. Like the LT1016, LT1116 and LT1671, this comparator has complementary outputs designed to interface directly to TTL or CMOS logic. The LT1394 may operate from either a single 5V supply or dual  $\pm 5V$  supplies. Low offset voltage specifications and high gain allow the LT1394 to be used in precision applications.

The LT1394 is designed for improved speed and stability for a wide range of operating conditions. The output stage provides active drive in both directions for maximum speed into TTL, CMOS or passive loads with minimal cross-conduction current. Unlike other fast comparators, the LT1394 remains stable even for slow transitions through the active region, which eliminates the need to specify a minimum input slew rate.

The LT1394 has an internal, TTL/CMOS compatible latch for retaining data at the outputs. The latch holds data as long as the LATCH pin is held high. Device parameters such as gain, offset and negative power supply current are not significantly affected by variations in negative supply voltage.

## TYPICAL APPLICATION

45MHz Single Supply Adaptive Trigger

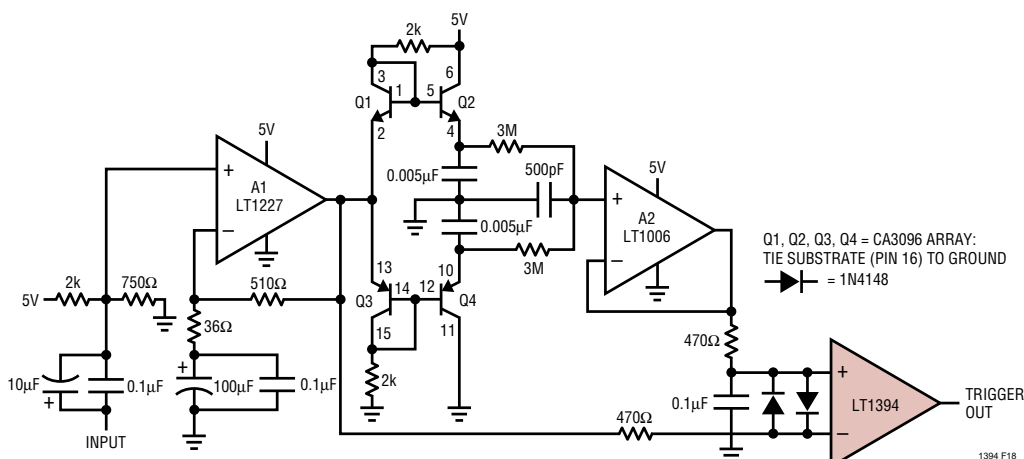

Propagation Delay vs  
Input Overdrive

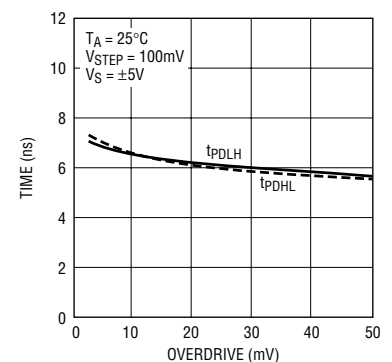

## ABSOLUTE MAXIMUM RATINGS (Note 1)

Total Supply Voltage ( $V^+$ to $V^-$ ) .....	12V	Operating Temperature Range .....	-40°C to 85°C
Positive Supply Voltage .....	7V	Specified Temperature Range (Note 3) ...	-40°C to 85°C
Negative Supply Voltage .....	-7V	Junction Temperature .....	150°C
Differential Input Voltage .....	$\pm 12V$	Storage Temperature Range .....	-65°C to 150°C
Input and Latch Current (Note 2) .....	$\pm 10mA$	Lead Temperature (Soldering, 10 sec) .....	300°C
Output Current (Continuous)(Note 2) .....	$\pm 20mA$		

## PACKAGE/ORDER INFORMATION

	ORDER PART NUMBER		ORDER PART NUMBER
	LT1394CMS8		LT1394CS8 LT1394IS8
	MS8 PART MARKING		S8 PART MARKING
	LTBH		1394 1394I

Consult factory for Military grade parts.

## ELECTRICAL CHARACTERISTICS

The ● denotes specifications which apply over the full operating temperature range, otherwise specifications are  $T_A = 25^\circ C$ .  
 $V^+ = 5V$ ,  $V^- = -5V$ ,  $V_{OUT(Q)} = 1.4V$ ,  $V_{LATCH} = V_{CM} = 0V$  unless otherwise noted.

SYMBOL	PARAMETER	CONDITIONS	MIN	TYP	MAX	UNITS
$V_{OS}$	Input Offset Voltage	$R_S \leq 100\Omega$ (Note 4)	●	0.8	2.5	mV
			●		4.0	mV
$\frac{\Delta V_{OS}}{\Delta T}$	Input Offset Voltage Drift		●	4		$\mu V/^\circ C$
$I_{OS}$	Input Offset Current		●	0.1	0.5	$\mu A$
			●		0.8	$\mu A$
$I_B$	Input Bias Current	(Note 5)	●	2	4.5	$\mu A$
			●		7.0	$\mu A$
$V_{CMR}$	Input Voltage Range (Note 6)	Single 5V Supply	●	-5	3.5	V
			●	0	3.5	V
CMRR	Common Mode Rejection Ratio	$-5V \leq V_{CM} \leq 3.5V$ , $T_A > 0^\circ C$	●	55	100	dB
		$-5V \leq V_{CM} \leq 3.3V$ , $T_A \leq 0^\circ C$	●	55		dB
		Single 5V Supply $0V \leq V_{CM} \leq 3.5V$ , $T_A > 0^\circ C$	●	55	100	dB
		$0V \leq V_{CM} \leq 3.3V$ , $T_A \leq 0^\circ C$	●	55		dB
PSRR	Power Supply Rejection Ratio	$4.6V \leq V^+ \leq 5.4V$	●	50	65	dB
		$-7V \leq V^- \leq -2V$	●	65	100	dB
$A_V$	Small Signal Voltage Gain	$1V \leq V_{OUT} \leq 2V$	●	750	1600	V/V
$V_{OH}$	Output Voltage Swing High	$V^+ \geq 4.6V$ , $I_{OUT} = 1mA$	●	2.7	3.1	V
		$V^+ \geq 4.6V$ , $I_{OUT} = 4mA$	●	2.4	3.0	V

## ELECTRICAL CHARACTERISTICS

The ● denotes specifications which apply over the full operating temperature range, otherwise specifications are  $T_A = 25^\circ\text{C}$ .  $V^+ = 5\text{V}$ ,  $V^- = -5\text{V}$ ,  $V_{\text{OUT(Q)}} = 1.4\text{V}$ ,  $V_{\text{LATCH}} = V_{\text{CM}} = 0\text{V}$  unless otherwise noted.

SYMBOL	PARAMETER	CONDITIONS		MIN	TYP	MAX	UNITS
$V_{\text{OL}}$	Output Voltage Swing Low	$I_{\text{OUT}} = -4\text{mA}$ $I_{\text{OUT}} = -10\text{mA}$	●		0.3	0.5	V
					0.4		V
$I^+$	Positive Supply Current		●		6	8.5 10.0	mA mA
$I^-$	Negative Supply Current		●		1.2	2.2 2.5	mA mA
$V_{\text{IH}}$	LATCH Pin High Input Voltage		●	2			V
$V_{\text{IL}}$	LATCH Pin Low Input Voltage		●			0.8	V
$I_{\text{IL}}$	LATCH Pin Current	$V_{\text{LATCH}} = 0\text{V}$	●		-4	-10	$\mu\text{A}$
$t_{\text{PD}}$	Propagation Delay (Note 7)	$\Delta V_{\text{IN}} = 100\text{mV}$ , $V_{\text{OD}} = 5\text{mV}$			7	9	ns
			●			14	ns
$\Delta t_{\text{PD}}$	Differential Propagation Delay (Note 7)	$\Delta V_{\text{IN}} = 100\text{mV}$ , $V_{\text{OD}} = 5\text{mV}$			0.5	2.2	ns
$t_{\text{LPD}}$	Latch Propagation Delay (Note 8)				6		ns
$t_{\text{SU}}$	Latch Setup Time (Note 8)				-0.4		ns
$t_{\text{H}}$	Latch Hold Time (Note 8)				2		ns
$t_{\text{PW(D)}}$	Minimum Disable Pulse Width				3		ns

**Note 1:** Absolute Maximum Ratings are those values beyond which the life of a device may be impaired.

**Note 2:** This parameter is guaranteed to meet specified performance through design and characterization. It has not been tested.

**Note 3:** The LT1394CMS8 and LT1394CS8 are guaranteed to meet specified performance from  $0^\circ\text{C}$  to  $70^\circ\text{C}$  and are designed, characterized and expected to meet these extended temperature limits, but are not tested at  $-40^\circ\text{C}$  and  $85^\circ\text{C}$ . The LT1394IS8 is guaranteed to meet the extended temperature limits.

**Note 4:** Input offset voltage ( $V_{\text{OS}}$ ) is defined as the average of the two voltages measured by forcing first one output, then the other to 1.4V.

**Note 5:** Input bias current ( $I_{\text{B}}$ ) is defined as the average of the two input currents.

**Note 6:** Input voltage range is guaranteed in part by CMRR testing and in part by design and characterization.

**Note 7:**  $t_{\text{PD}}$  and  $\Delta t_{\text{PD}}$  cannot be measured in automatic handling equipment with low values of overdrive. The LT1394 is 100% tested with a 100mV step and 20mV overdrive. Correlation tests have shown that  $t_{\text{PD}}$  and  $\Delta t_{\text{PD}}$  limits can be guaranteed with this test, if additional DC tests are performed to guarantee that all internal bias conditions are correct. Propagation delay ( $t_{\text{PD}}$ ) is measured with the overdrive added to the actual  $V_{\text{OS}}$ . Differential propagation delay is defined as:

$$\Delta t_{\text{PD}} = t_{\text{PDLH}} - t_{\text{PDHL}}$$

**Note 8:** Latch propagation delay ( $t_{\text{LPD}}$ ) is the delay time for the output to respond when the LATCH pin is deasserted. Latch setup time ( $t_{\text{SU}}$ ) is the interval in which the input signal must remain stable prior to asserting the latch signal. Latch hold time ( $t_{\text{H}}$ ) is the interval after the latch is asserted in which the input signal must remain stable.

# TYPICAL PERFORMANCE CHARACTERISTICS

**Gain Characteristics**

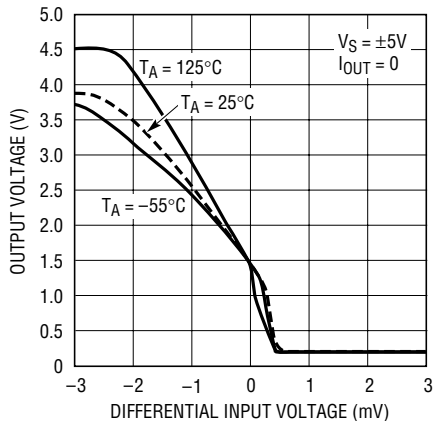

1394 G01

**Propagation Delay vs Load Capacitance**

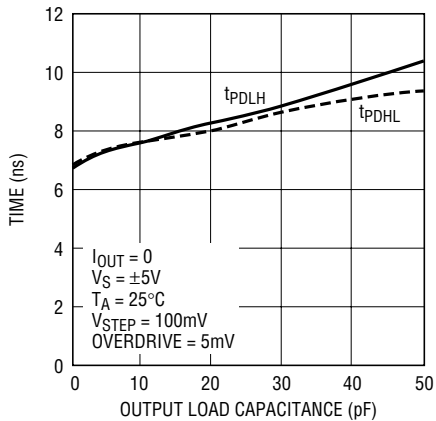

1394 G02

**Propagation Delay vs Positive Supply Voltage**

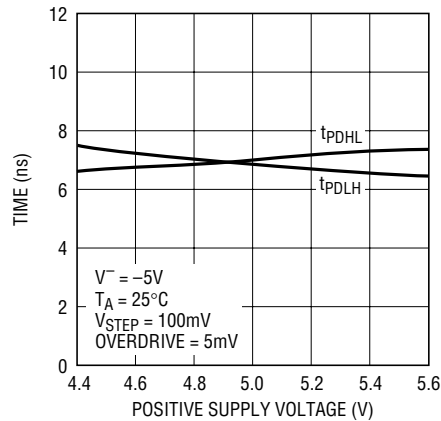

1394 G03

**Propagation Delay vs Input Overdrive**

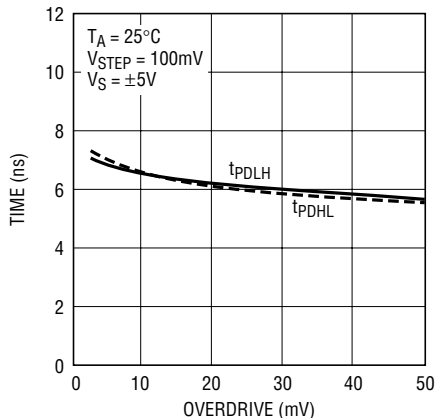

1394 TA02

**Propagation Delay vs Source Resistance**

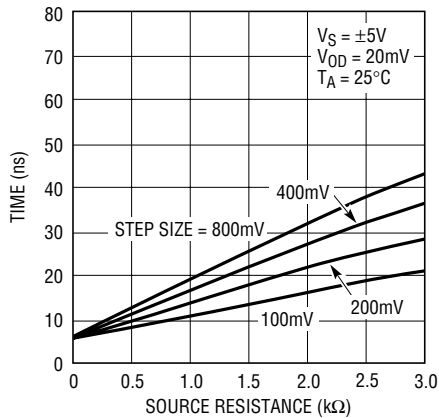

1394 G04

**Propagation Delay vs Temperature**

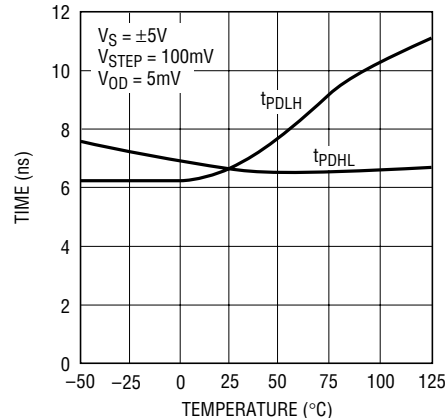

1394 G05

**Input Offset Voltage vs Temperature**

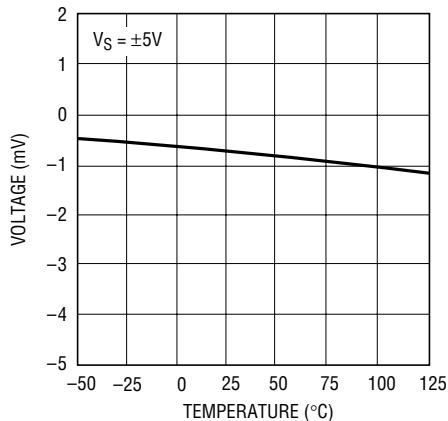

LT1394 G06

**Input Bias Current vs Temperature**

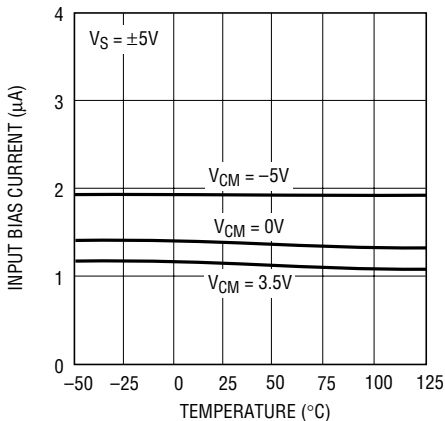

LT1394 G07

**Positive Common Mode Limit vs Temperature**

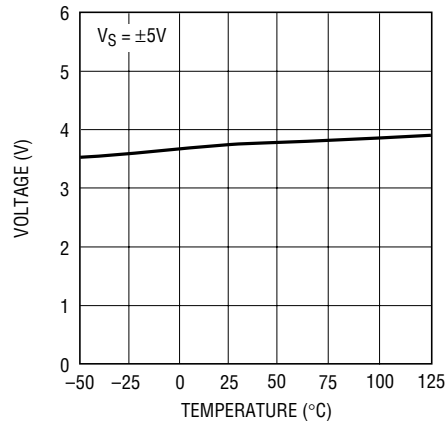

1394 G08

# TYPICAL PERFORMANCE CHARACTERISTICS

**Negative Common Mode Limit vs Temperature**

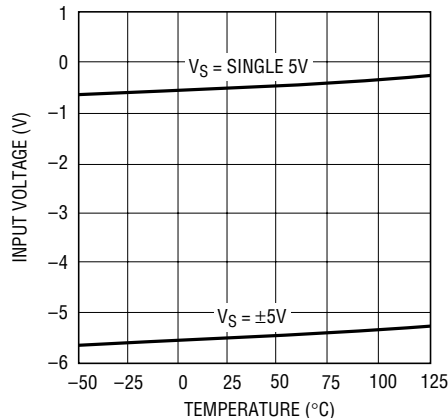

LT1394 G09

**Output Low Voltage ( $V_{OL}$ ) vs Output Sink Current**

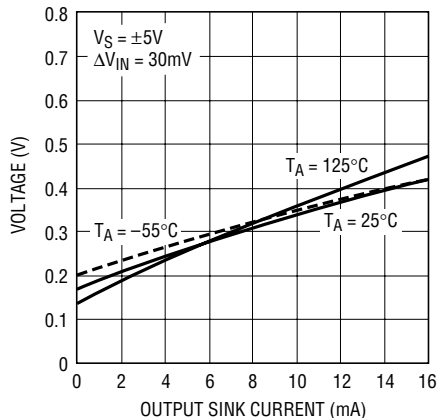

1394 G10

**Output High Voltage ( $V_{OH}$ ) vs Output Source Current**

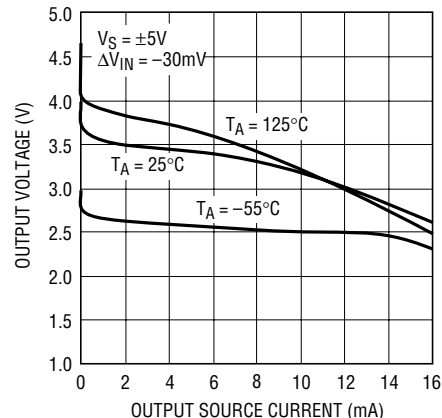

1394 G11

**Positive Supply Current vs  $V^+$  Supply Voltage**

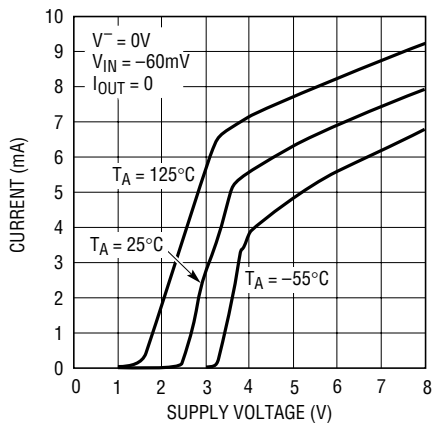

1394 G12

**Positive Supply Current vs Switching Frequency**

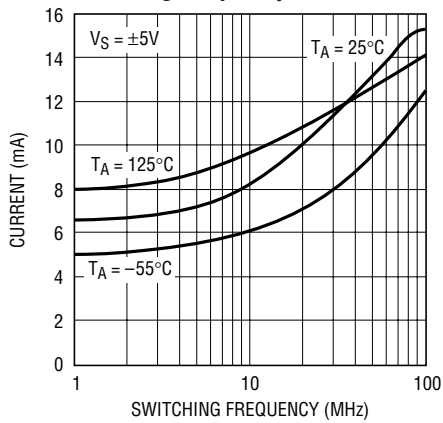

1394 G13

**Negative Supply Current vs  $V^-$  Supply Voltage**

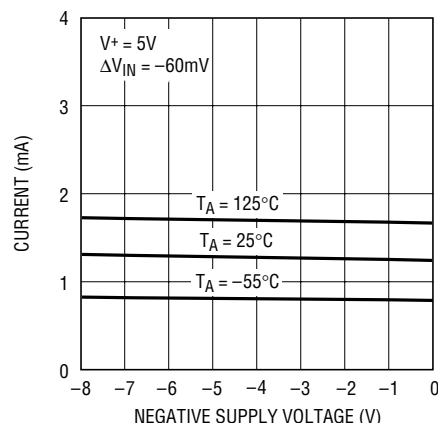

1394 G14

**Latch Pin Current vs Temperature**

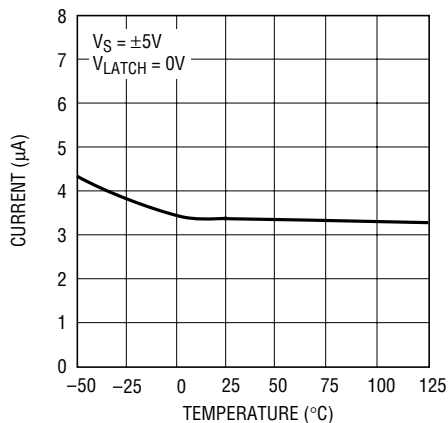

LT1394 G15

**Response to 100MHz  $\pm 10mV$  Sine Wave**

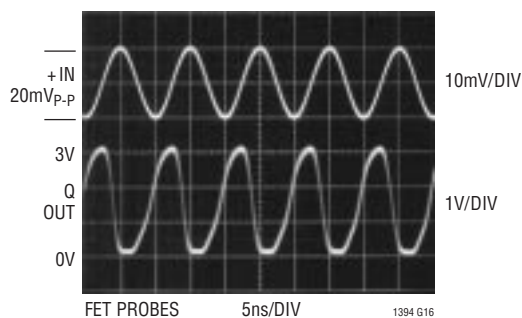

1394 G16

## TYPICAL PERFORMANCE CHARACTERISTICS

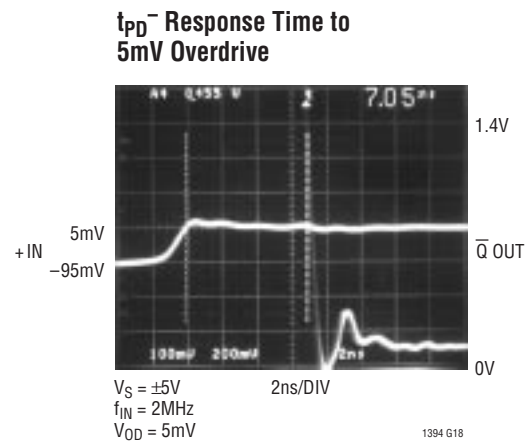
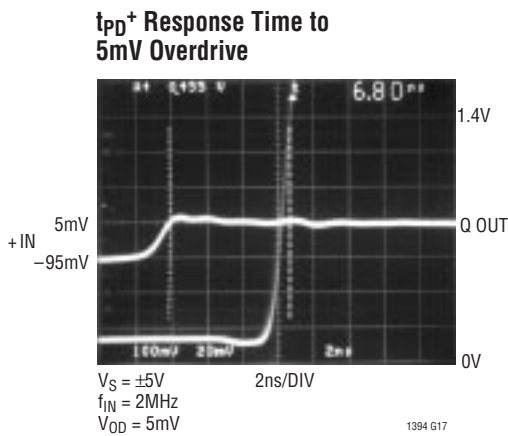

## PIN FUNCTIONS

**V<sup>+</sup> (Pin 1):** Positive Supply Voltage. Normally 5V.

**+IN (Pin 2):** Noninverting Input.

**-IN (Pin 3):** Inverting Input.

**V<sup>-</sup> (Pin 4):** Negative Supply Voltage. Normally either 0V or -5V.

**LATCH ENABLE (Pin 5):** Latch Control Pin. When high, the outputs remain in a latched condition, independent of the current state of the inputs.

**GND (Pin 6):** Ground.

**Q OUT (Pin 7):** Noninverting Logic Output. This pin is high when +IN is above -IN and LATCH ENABLE is low.

**Q̄ OUT (Pin 8):** Inverting Logic Output. This pin is low when +IN is above -IN and LATCH ENABLE is low.

## TIMING DIAGRAMS

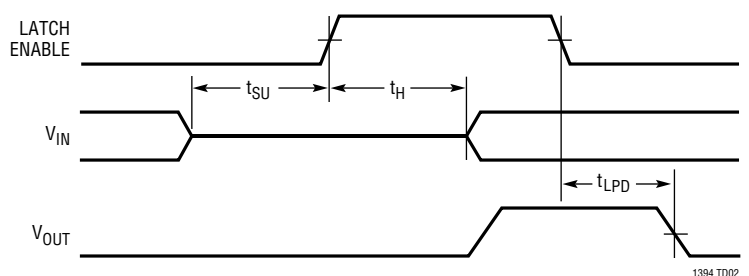
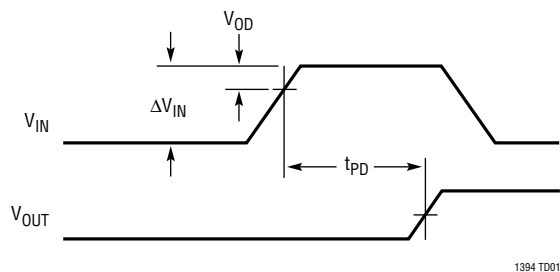

## APPLICATIONS INFORMATION

### Common Mode Considerations

The LT1394 is specified for a common mode range of  $-5V$  to  $3.5V$  on a  $\pm 5V$  supply or a common mode range of  $0V$  to  $3.5V$  on a single  $5V$  supply. A more general consideration is that the common mode range is  $0V$  below the negative supply and  $1.5V$  below the positive supply, independent of the actual supply voltage. The criterion for common mode limit is that the output still responds correctly to a small differential input signal.

When either input signal falls below the negative common mode limit, the internal PN diode formed with the substrate can turn on, resulting in significant current flow through the die. An external Schottky clamp diode between the input and the negative rail can speed up recovery from negative overdrive by preventing the substrate diode from turning on. The zero-crossing detector in Figure 1 demonstrates the use of a fast clamp diode.

The zero-crossing detector terminates the transmission line at its  $50\Omega$  characteristic impedance. Negative inputs should not fall below  $-2V$  to keep the signal current within the clamp diode's maximum forward rating. Positive inputs should not exceed the device's absolute maximum ratings or the power rating on the terminating resistor.

Either input may go above the positive common mode limit without damaging the comparator. The upper voltage limit is determined by an internal diode from each input to the positive supply. The input may go above the positive supply as long as it does not go far enough above it to conduct more than  $10mA$ . Functionality will continue if the remaining input stays within the allowed common mode range. There will, however, be an increase in propagation delay as the input signal switches back into the common mode range.

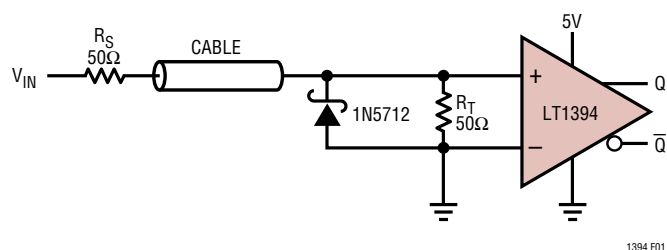

Figure 1. Fast Zero-Crossing Detector

### Input Bias Current

Input bias current is measured with the output held at  $1.4V$ . As with any PNP differential input stage, the LT1394 bias current flows out of the device. It will go to zero on an input which is high and double on an input which is low.

### LATCH Pin Dynamics

The LATCH pin is intended to retain input data (output latched) when the LATCH pin goes high. The pin will float to a high state when disconnected, so a flow-through condition requires that the LATCH pin be grounded. The LATCH pin is designed to be driven with either a TTL or CMOS output. It has no built-in hysteresis.

To guarantee data retention, the input signal must remain valid at least  $2ns$  after the latch goes high (hold time), and must be valid at least  $-0.4ns$  before the latch goes high (setup time). The negative setup time simply means that the data arriving  $0.4ns$  after (rather than before) the latch signal is valid. When the latch signal goes low, new data will appear at the output in approximately  $6ns$  (latch propagation delay).

### Measuring Response Time

To properly measure the response of the LT1394 requires an input signal source with very fast rise times and exceptionally clean settling characteristics. The last requirement comes about because the standard comparator test calls for an input step size that is large compared to the overdrive amplitude. Typical test conditions are  $100mV$  step size with  $5mV$  overdrive. This requires an input signal that settles to within  $1%$  ( $1mV$ ) of final value in only a few nanoseconds with no ringing or settling tail. Ordinary high speed pulse generators are not capable of generating such a signal, and in any case, no ordinary oscilloscope is capable of displaying the waveform to check its fidelity. Some means must be used to inherently generate a fast, clean edge with known final value. The circuit shown in Figure 2 is the best electronic means of generating a fast, clean step to test comparators. It uses a very fast transistor in a common base configuration. The transistor is switched off with a fast edge from the generator and the collector voltage settles to exactly  $0V$  in just a few nanoseconds. The most important feature of this

APPLICATIONS INFORMATION

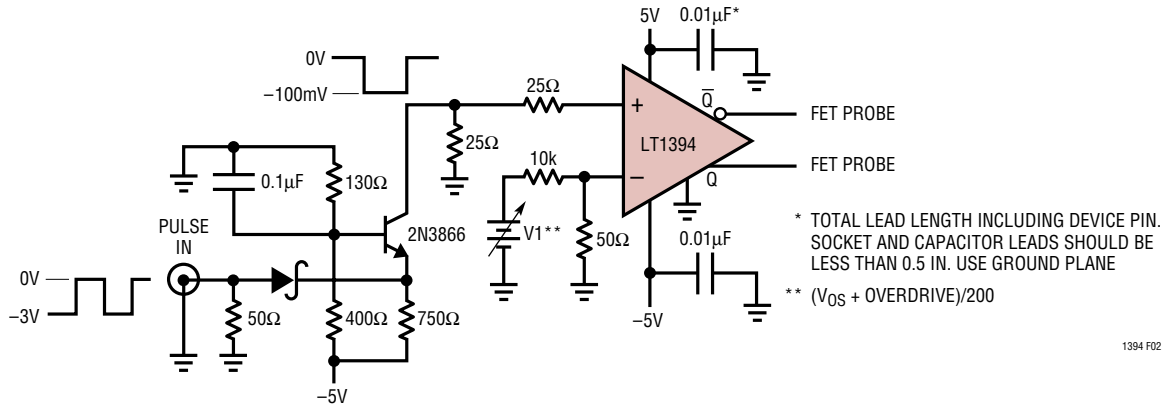

Figure 2. Response Time Test Circuit

circuit is the lack of feedthrough from the generator to the comparator input. This prevents overshoot on the comparator input, which would give a false fast reading on comparator response time.

To adjust the circuit for exactly 5mV overdrive, V1 is adjusted so that the LT1394 output under test settles to 1.4V (in the linear region). Then V1 is changed by -1V to set overdrive to 5mV.

High Speed Design Techniques

A substantial amount of design effort has made the LT1394 relatively easy to use. It is much less prone to oscillation than some slower comparators, even with slow input signals. However, as with any high speed comparator, there are a number of pitfalls which may arise because of PC board layout and design. The most common problems involve power supply bypassing. Bypassing is necessary to maintain low supply impedance. DC resistance and inductance in supply wires and PC traces can quickly build up to unacceptable levels. This allows the supply line to move with changing internal current levels of the connected devices. This will almost always result in improper operation. In addition, adjacent devices connected through an unbypassed supply can interact with each other through the finite supply impedances. Bypass capacitors furnish a simple solution to this problem by providing a local reservoir of energy at the device, keeping supply impedances low.

Bypass capacitors should be as close as possible to the LT1394. A good high frequency capacitor such as a 0.1μF

ceramic is recommended, in parallel with a larger capacitor such as a 4.7μF tantalum.

Poor trace routes and high source impedances are also common sources of problems. Be sure to keep trace lengths as short as possible, and avoid running any output trace adjacent to an input trace to prevent unnecessary coupling. If output traces are longer than a few inches, be sure to terminate them with a resistor to eliminate any reflections that may occur. Resistor values are typically 250Ω to 400Ω. Also, be sure to keep source impedances as low as possible, preferably 1kΩ or less.

Crystal Oscillators

Figure 3's circuits are crystal oscillators. In the circuit (a) the resistors at the LT1394's positive input set a DC bias point. The 2k-0.068μF path sets up phase shifted feedback and the circuit looks like a wideband unity-gain follower at DC. The crystal's path provides resonant positive feedback and stable oscillation occurs. The circuit (b) is similar, but supports oscillation frequencies to 30MHz. Above 10MHz, AT-cut crystals operate in overtone mode. Because of this, oscillation can occur at multiples of the desired frequency. The damper network rolls off gain at high frequency, ensuring proper operation.

Switchable Output Crystal Oscillator

Figure 4 permits crystals to be electronically switched by logic commands. This circuit is similar to the previous examples, except that oscillation is only possible when one of the logic inputs is biased high.

## APPLICATIONS INFORMATION

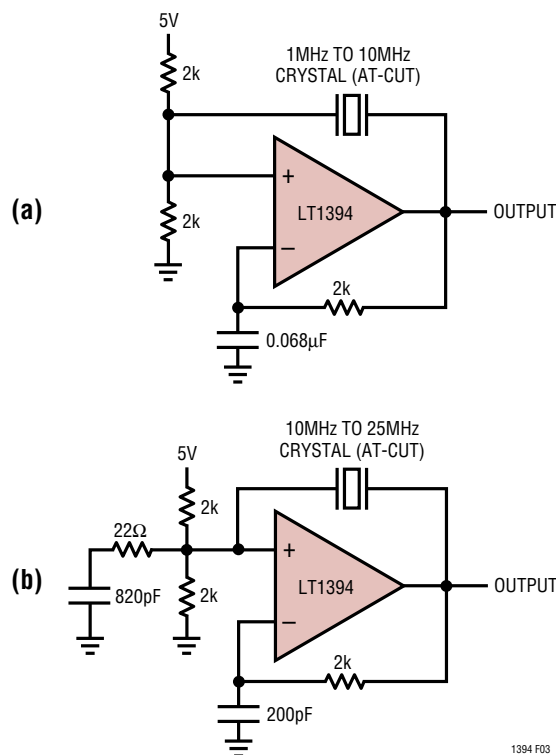

**Figure 3. Crystal Oscillators for Outputs to 30MHz. Circuit (b)'s Damper Network Suppresses Overtone Crystal's Harmonic Modes**

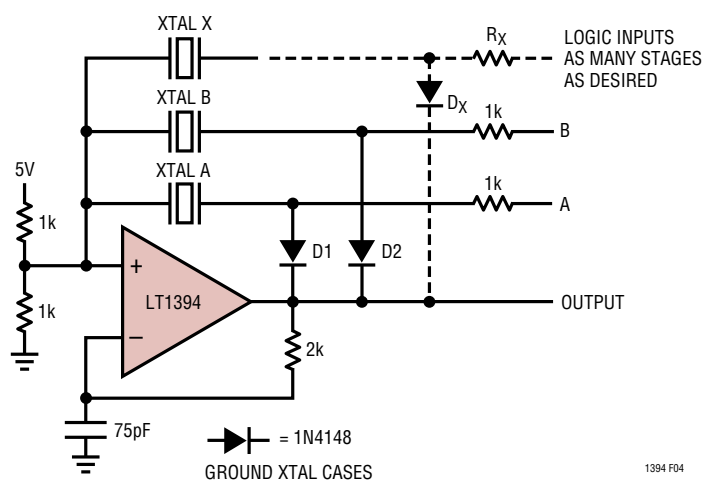

**Figure 4. Switchable Output Crystal Oscillator. Biasing A or B High Places Associated Crystal in Feedback Path. Additional Crystal Branches Are Permissible**

### Temperature-Compensated Crystal Oscillator (TXCO)

Figure 5 is a temperature-compensated crystal oscillator (TXCO). This circuit reduces oscillator temperature drift by inserting a temperature-dependent compensatory correction into the crystal's frequency trimming network. This open-loop correction technique relies on cancellation of the temperature characteristics of the oscillator, which are quite repeatable.

The LT1394 and associated components form the crystal oscillator, operating similarly to Figure 3's examples. The LM134, a temperature-dependent current source, biases A1. A1 takes gain referred to the LM134's output and the negative offset supplied via the 470kΩ-LT1004 reference path. Note that the LT1004's negative voltage bias is bootstrapped from the oscillator's output, maintaining single supply operation. This arrangement delivers temperature-dependent bias to the varactor diode, causing a scaled variation in the crystal's resonance versus ambient temperature. The varactor's bias-dependent capacitance shift pulls crystal frequency to complement the circuit's temperature drift. The simple first order fit provided by the compensation is very effective. Figure 6 shows results. The  $-70\text{ppm}$  frequency shift over  $0^\circ\text{C}$  to  $70^\circ\text{C}$  is corrected within a few ppm. The "FREQ SET" trim also biases the varactor, allowing accurate output frequency setting. It is worth noting that better compensation is possible by including higher order terms in the temperature-to-voltage conversion.

### 18ns, 500µV Sensitivity Comparator

The ultimate limitation on comparator sensitivity is available gain. Unfortunately, increasing gain invariably involves giving up speed. The gain vs. speed trade-off in a fast comparator is usually a practical compromise designed to satisfy most applications. Some situations, however, require more sensitivity (e.g., higher gain) with minimal impact on speed. Figure 7's circuit adds a differential preamplifier ahead of the LT1394, increasing gain. This permits  $500\mu\text{V}$  comparisons in 18ns. A parallel path DC stabilization approach eliminates preamplifier drift as an error source. A1 is the differential preamplifier, operating at a gain of 100. Its output is AC-coupled to the LT1394.

APPLICATIONS INFORMATION

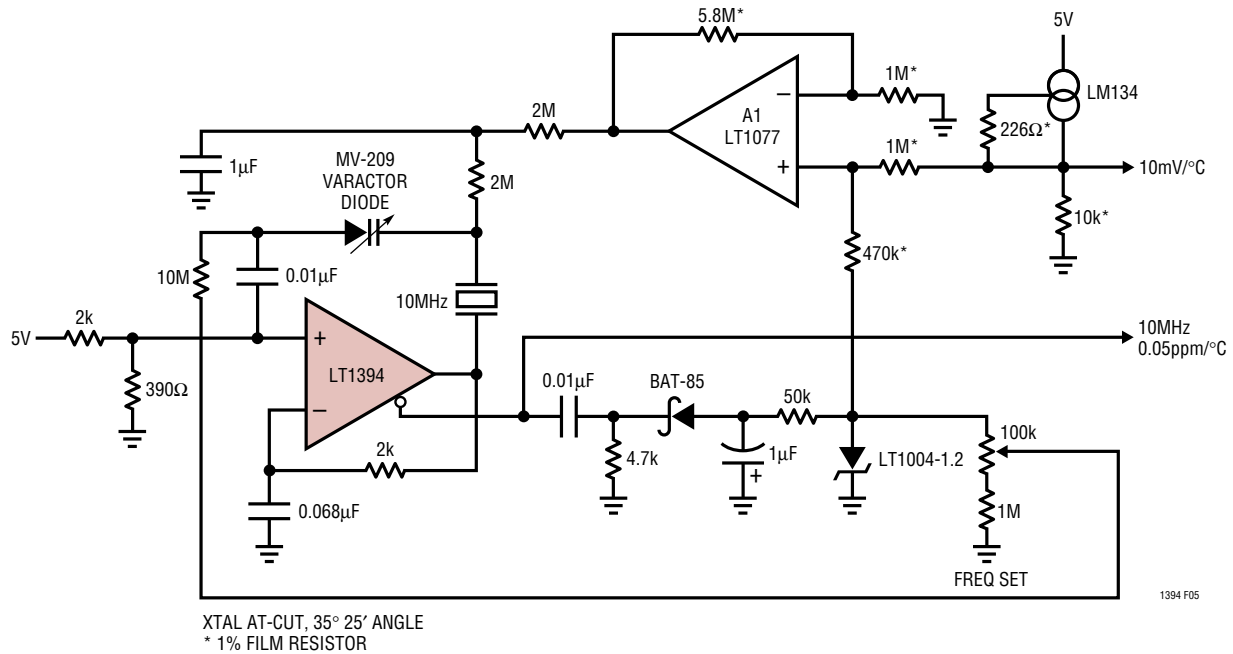

Figure 5. Temperature-Compensated 10MHz Crystal Oscillator. Temperature-Dependent Varactor Bias Reduces Drift by 20:1

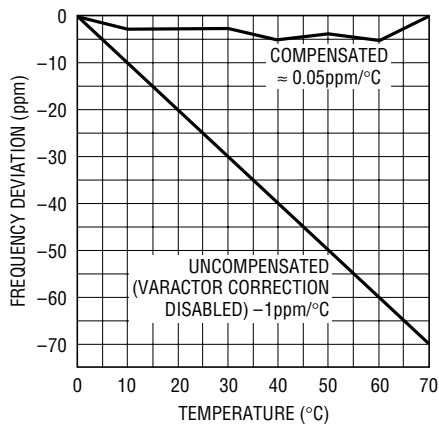

Figure 6. Figure 5's Compensated vs Uncompensated Temperature Dependence. First Order Compensation Reduces Oscillator Drift to 0.05ppm/°C

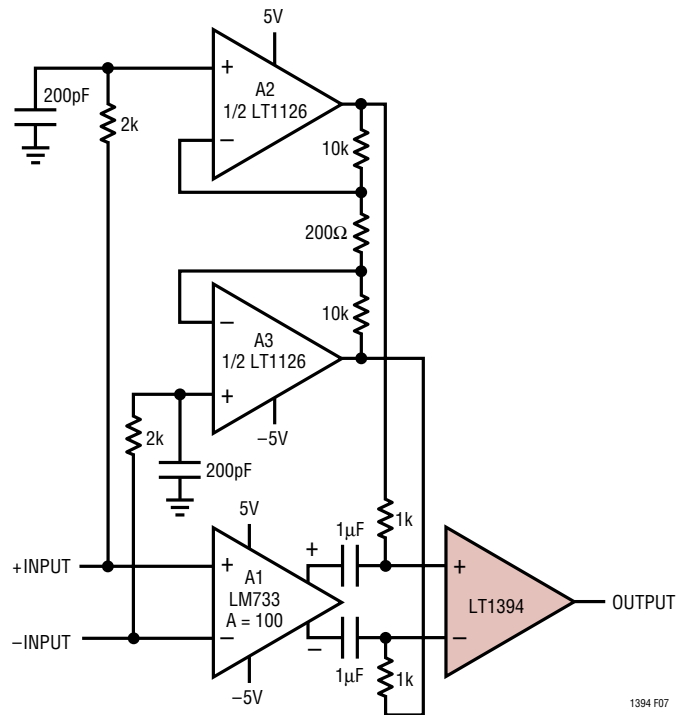

Figure 7. Parallel Preamplified Paths Allow 18ns Comparator Response to 500µV Overdrive

## APPLICATIONS INFORMATION

A1 has poorly defined DC characteristics, necessitating some form of DC correction. A2 and A3, operating at a differential gain of 100, provide this function. They differentially sense a band limited version of A1's inputs and feed DC and low frequency amplified information to the comparator. The low frequency roll-off of A1's signal path complements A2-A3's high frequency roll-off. The summation of these two signal channels at the LT1394 inputs results in flat response from DC to high frequency.

Figure 8 shows waveforms for the high gain comparator. Trace A is a 500 $\mu$ V overdrive on a 1mV step applied to the circuit's positive input (negative input grounded). Trace B shows the resulting amplified step at A1's positive output. Trace C is A2's band limited output. A1's wideband output combines with A2's DC corrected information to yield the

correct, amplified composite signal at the LT1394's positive input in Trace D. The LT1394's output is Trace E. Figure 9 details circuit propagation delay. The output responds in 18ns to a 500 $\mu$ V overdrive on a 1mV step. Figure 10 plots response time versus overdrive. As might be expected, propagation delay decreases at higher overdrives. A1's noise limits usable sensitivity.

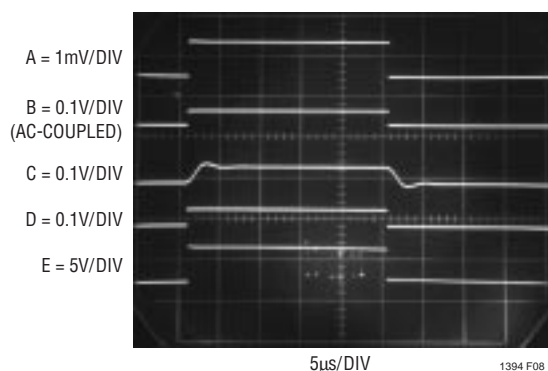

**Figure 8. 500 $\mu$ V Input (Trace A) Is Split into Wideband and Low Frequency Gain Paths (Traces B and C) and Recombined (Trace D). Comparator Output Is Trace E**

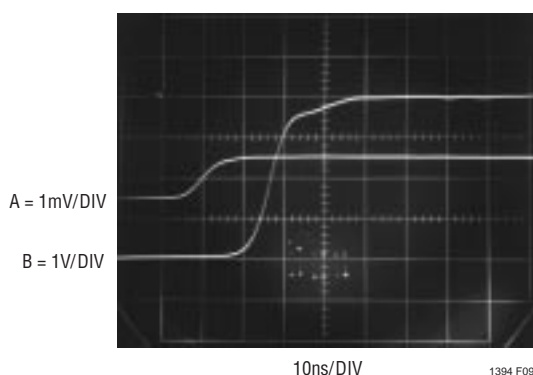

**Figure 9. Parallel Path Comparator Shows 18ns Response (Trace B) to 500 $\mu$ V Overdrive (Trace A)**

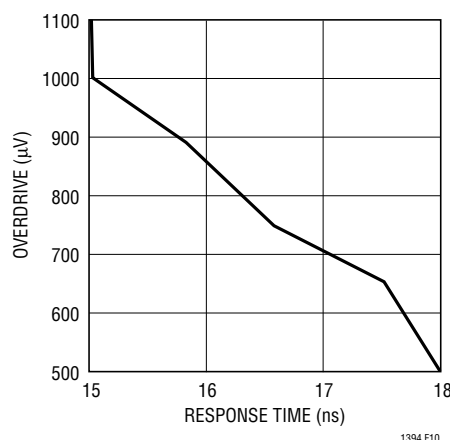

**Figure 10. Response Time vs Overdrive for the Composite Comparator**

### Voltage-Controlled Delay

The ability to set a precise, predictable delay has broad application in pulse circuitry. Figure 11's configuration sets a 0 to 300ns delay from a corresponding 0V to 3V control voltage. It takes advantage of the LT1394's speed and the clean dynamics of an emitter switched current source.

Q1 and Q2 form a current source that charges the 1000pF capacitor. When the trigger input is high (Trace A, Figure 12) both Q3 and Q4 are on. The current source is off and Q2's collector (Trace B) is at ground. The latch input at the LT1394 prevents it from responding and its output remains high. When the trigger input goes low, the LT1394's latch input is disabled and its output drops low. Q4's collector (Trace C) lifts and Q2 comes on, delivering constant current to the 1000pF capacitor (Trace B). The resulting linear ramp at the LT1394's positive input is compared to the delay programming voltage input. When a crossing occurs, the comparator goes high (Trace D). The length of time the comparator was low is directly proportional to the

APPLICATIONS INFORMATION

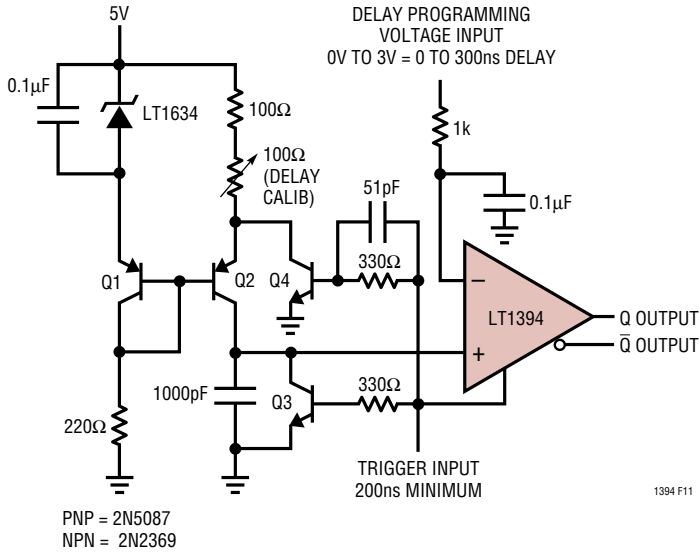

**Figure 11. Fast, Precise, Voltage-Controlled Delay. Emitter Switched Current Source Has Clean, Predictable Dynamics**

delay programming voltage. The fast switching and ramp linearity permits 1ns accuracy and 100ps repeatability. Figure 13, a high speed expansion of the current source turn-on, details the clean switching. Q4 goes off within 2ns of the trigger input (Trace A) dropping low, enabling the current source (Q2's emitter is Trace C). Concurrently, the 1000pF capacitor's ramp (Trace B) begins. The LT1394's output (Trace D) drops low about 7ns later, returning high after crossing (in this case) a relatively low programming voltage. Figure 14 juxtaposes the waveforms differently, permitting enhanced study of circuit timing. Switching begins with the input trigger falling low (Trace A). The ramp (Trace C) begins 3ns after the current source turns on (Q2 emitter is Trace D). The output pulse (Trace B) begins about 4ns later.

To calibrate this circuit apply a trigger input and 3V to the programming input. Adjust the 100Ω trim for a 300ns width at the LT1394's output.

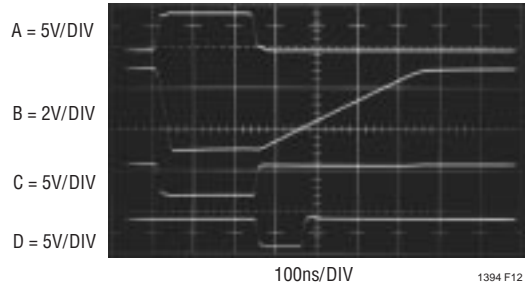

**Figure 12. Voltage-Controlled Delay's Waveforms. Programming Voltage Determines Delay Between Input (Trace A) Falling Edge and Output (Trace D) Rising Edge. High Linearity Timing Ramp (Trace B) Permits 1ns Accuracy and 100ps Repeatability**

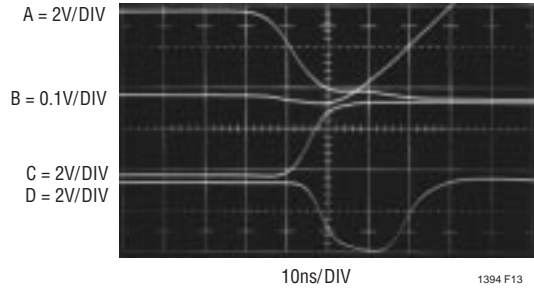

**Figure 13. High Speed Expansion of Figure 12. Ramp (Trace B) Begins When Trigger (Trace A) Falls and Current Source Turns On (Trace C). Trace D is Output**

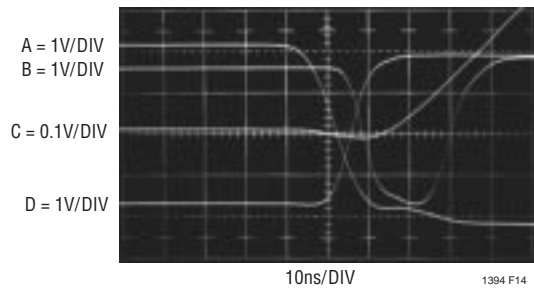

**Figure 14. Delay's Output Switching Begins with Trigger Falling Low (Trace A). Ramp (Trace C) Starts 3ns After Current Source Turn-On (Trace D). Output (Trace B) Begins 4ns Later**



## APPLICATIONS INFORMATION

### High Speed Adaptive Trigger Circuit

Line and fibre-optic receivers often require an adaptive trigger to compensate for variations in signal amplitude and DC offsets. The circuit in Figure 18 triggers on 2mV to 175mV signals from 100Hz to 45MHz while operating from a single 5V rail. A1, operating at a gain of 15, provides wideband AC gain. The output of this stage biases a 2-way peak detector (Q1 through Q4). The maximum peak is stored in Q2's emitter capacitor, while the minimum excursion is retained in Q4's emitter capacitor. The DC value of the midpoint of A1's output signal appears at the junction of the 500pF capacitor and the 3M $\Omega$  units. This point always sits midway between the signal's excursions, regardless of absolute amplitude. This signal-adaptive voltage is buffered by A2 to set the trigger voltage at the LT1394's positive input. The LT1394's negative input is biased directly from A1's output. The LT1394's output, the circuit's output, is unaffected by >85:1 signal amplitude variations. Bandwidth limiting in A1 does not affect triggering because the adaptive trigger threshold varies ratiometrically to maintain circuit output.

Figure 19 shows operating waveforms at 45MHz. Trace A's input produces Trace B's amplified output at A1. The comparator's output is Trace C.

Split supply versions of this circuit can achieve bandwidths to 50MHz with wider input operating range.

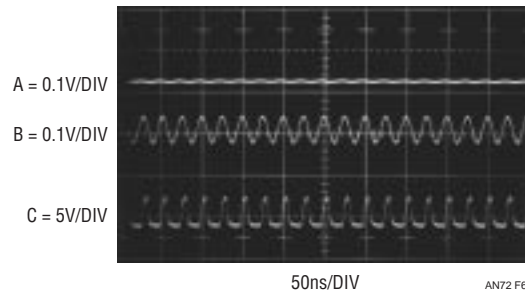

**Figure 19. Adaptive Trigger Responding to a 40MHz, 5mV Input. Input Amplitude Variations from 2mV to 175mV Are Accommodated**

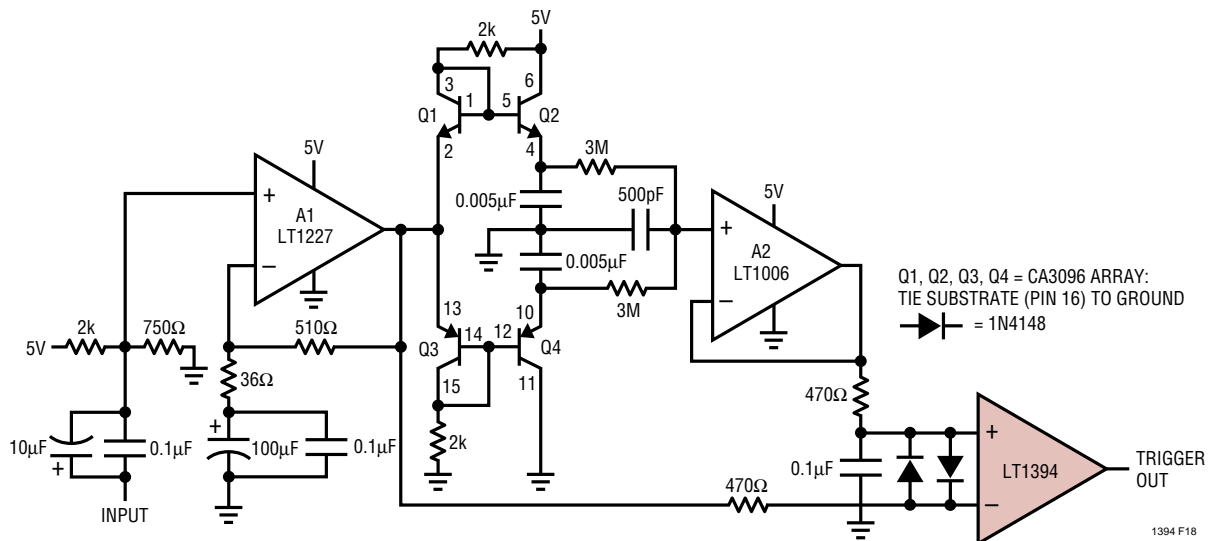

**Figure 18. 45MHz Single Supply Adaptive Trigger. Output Comparator's Threshold Varies Ratiometrically with Input Amplitude, Maintaining Data Integrity over > 85:1 Input Amplitude Range**

**PACKAGE DESCRIPTION** Dimensions in inches (millimeters) unless otherwise noted.

**MS8 Package**  
**8-Lead Plastic MSOP**  
 (LTC DWG # 05-08-1660)

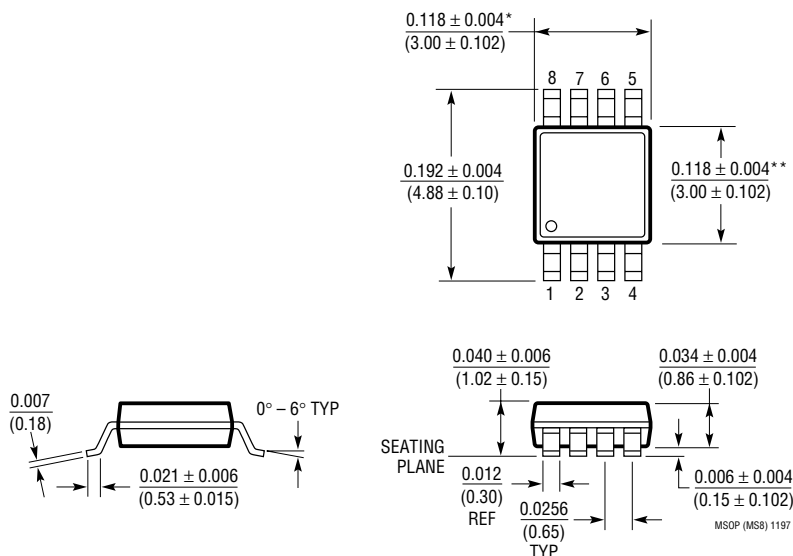

\* DIMENSION DOES NOT INCLUDE MOLD FLASH, PROTRUSIONS OR GATE BURRS. MOLD FLASH, PROTRUSIONS OR GATE BURRS SHALL NOT EXCEED 0.006" (0.152mm) PER SIDE  
 \*\* DIMENSION DOES NOT INCLUDE INTERLEAD FLASH OR PROTRUSIONS. INTERLEAD FLASH OR PROTRUSIONS SHALL NOT EXCEED 0.006" (0.152mm) PER SIDE

**S8 Package**  
**8-Lead Plastic Small Outline (Narrow 0.150)**  
 (LTC DWG # 05-08-1610)

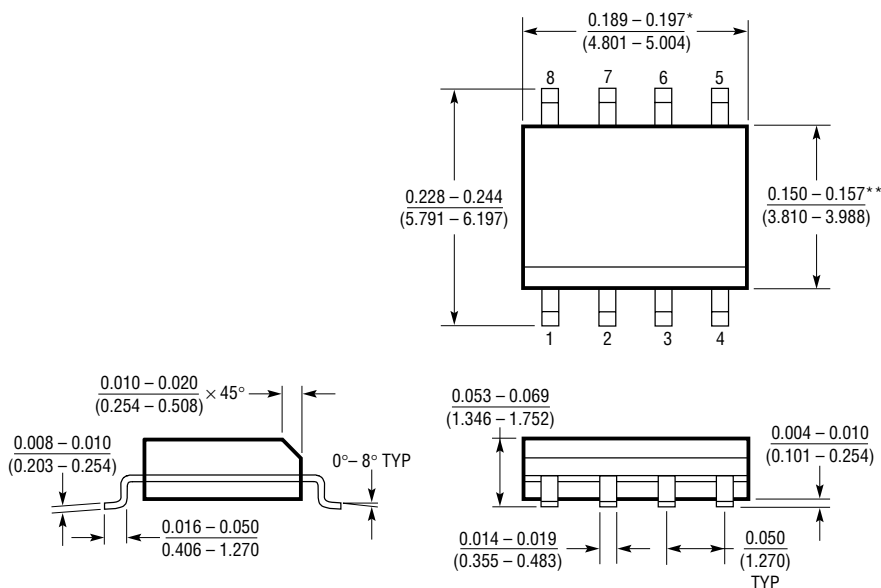

\* DIMENSION DOES NOT INCLUDE MOLD FLASH. MOLD FLASH SHALL NOT EXCEED 0.006" (0.152mm) PER SIDE  
 \*\* DIMENSION DOES NOT INCLUDE INTERLEAD FLASH. INTERLEAD FLASH SHALL NOT EXCEED 0.010" (0.254mm) PER SIDE

S08 0996

## TYPICAL APPLICATION

### Voltage-Controlled Crystal Oscillator (VCXO)

Figure 20, a variant of the basic crystal oscillator, permits voltage tuning the output frequency. Such voltage-controlled crystal oscillators (VCXO) are often employed where slight variation of a stable carrier is required. This example is specifically intended to provide a 4× NTSC sub-carrier tunable oscillator suitable for phase locking.

The LT1394 is set up as a crystal oscillator, operating similarly to Figure 3 (a). The varactor diode is biased from the tuning input. The tuning network is arranged so a 0V to 5V drive provides a reasonably symmetric, broad tuning range around the 14.31818MHz center frequency. The indicated selected capacitor sets tuning bandwidth. It should be picked to complement loop response in phase locking applications. Figure 21 is a plot of tuning input voltage versus frequency deviation. Tuning deviation from the 4× NTSC 14.31818MHz center frequency exceeds ±240ppm for a 0V to 5V input.

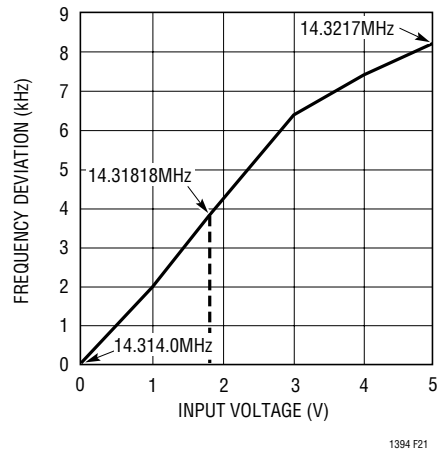

Figure 21. Control Voltage vs Output Frequency for Figure 15. Tuning Deviation from Center Frequency Exceeds ±240ppm

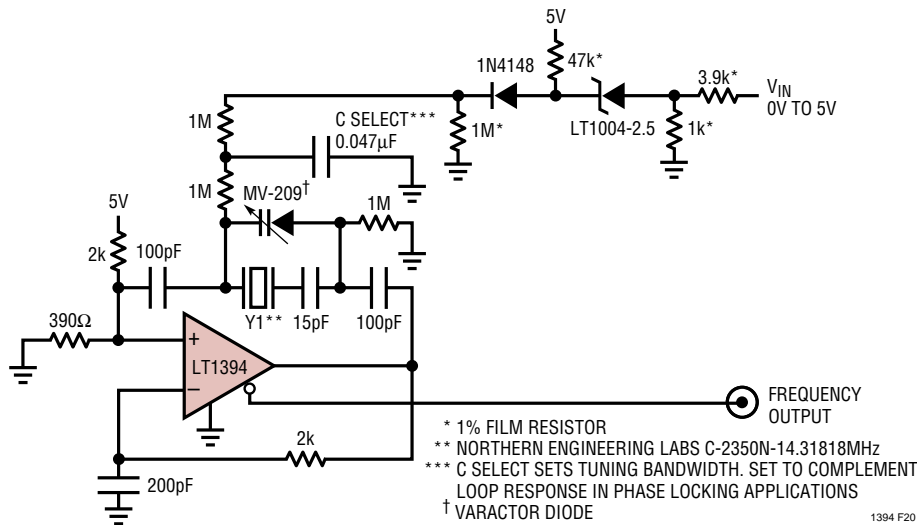

Figure 20. A 4× NTSC Sub-Carrier Voltage-Tunable Crystal Oscillator. Tuning Range and Bandwidth Accommodate Variety of Phase Locked Loops

## RELATED PARTS

PART NUMBER	DESCRIPTION	COMMENTS
LT1016	UltraFast Precision Comparator	Industry Standard 10ns Comparator
LT1116	12ns Single Supply Ground-Sensing Comparator	Single Supply Version of LT1016
LT1671	Fast Single Supply Comparator	60ns, 450µA Single Supply Comparator
LT1720	UltraFast Dual Single Supply Comparator	Dual 4.5ns, 4mA Single Supply Comparator

## Looking for pricing, stock, or lifecycle information?

Click below to explore more details on WIN SOURCE:

 [View LT1394IS8#PBF on WIN SOURCE](#)

 [Linear Technology](#) Information

## Optimize Your Supply Chain with WIN SOURCE Solutions

-  Global Sourcing Solution
-  Obsolete Management
-  Cost Control Management
-  Shortage Management
-  Alternative Solution
-  Excess Inventory Management