

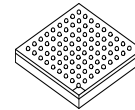

**THE DATASHEET OF
SCF5250CAG120R2**



SCF5250



Package Information
 MAPBGA-196
 LQFP-144

Ordering Information: See [Table 1 on page 2](#)

SCF5250 Integrated ColdFire® Microprocessor Data Sheet

1 Introduction

This document provides an overview of the SCF5250 ColdFire® processor and general descriptions of SCF5250 features and its various modules.

The SCF5250 was designed as a system controller/decoder for compressed audio music players, especially portable and automotive CD and hard disk drive players. The 32-bit ColdFire core with Enhanced Multiply Accumulate (EMAC) unit provides optimum performance and code density for the combination of control code and signal processing required for audio decoding and post processing, file management, and system control.

Low power features include a hardwired CD ROM decoder, advanced 0.13um CMOS process technology, 1.2V core power supply, and on-chip 128KByte SRAM that enables Windows Media Audio (WMA) decoding without the need for external DRAM in CD applications.

The SCF5250 is also an excellent general purpose system controller with over 110 Dhrystone 2.1 MIPS @ 120MHz performance at a very competitive price. The

Contents

1 Introduction	1
2 SCF5250 Block Diagram	8
3 Signal Descriptions	8
4 Electrical Characteristics	21
5 Pin-Out and Package Information	36
6 Product Documentation	55

This document contains information on a product under development. Freescale reserves the right to change or discontinue this product without notice.

© Freescale Semiconductor, Inc., 2006. All rights reserved.

integrated peripherals and enhanced MAC unit allow the SCF5250 to replace both the microcontroller and the DSP in certain applications. Most peripheral pins can also be remapped as General Purpose I/O pins.

1.1 Orderable Part Numbers

Table 1 lists the orderable part numbers for the SCF5250 processor.

Table 1. Orderable Part Numbers

Orderable Part Number	Maximum Clock Frequency	Package Type	Operating Temperature Range	Part Status
SCF5250LPV100	100 MHz	144 pin QFP	-20°C to 70°C	Leaded
SCF5250LAG100	100 MHz	144 pin QFP	-20°C to 70°C	Lead Free
SCF5250PV120	120 MHz	144 pin QFP	-20°C to 70°C	Leaded
SCF5250AG120	120 MHz	144 pin QFP	-20°C to 70°C	Lead Free
SCF5250DAG120 ¹	120 MHz	144 pin QFP	-20°C to 70°C	Lead Free
SCF5250EAG120 ²	120 MHz	144 pin QFP	-20°C to 70°C	Lead Free
SCF5250CPV120	120 MHz	144 pin QFP	-40°C to 85°C	Leaded
SCF5250CAG120	120 MHz	144 pin QFP	-40°C to 85°C	Lead Free
SCF5250VM120	120 MHz	196 ball MAPBGA	-20°C to 70°C	Lead Free

¹ SCF5250DAG120—This device has the same feature set, pin assignment and specification as SCF5250AG120 with the addition of including the cost of the MP3 decoder royalty to be paid to Thomson Licensing S.A. for use of the MP3 patent rights described at <http://mp3licensing.com/patents/index.html>.

² SCF5250EAG120—This device has the same feature set, pin assignment and specification as SCF5250AG120 with the addition of including the cost of the MP3 encoder and decoder royalty to be paid to Thomson Licensing S.A. for use of the MP3 patent rights described at <http://mp3licensing.com/patents/index.html>.

1.2 SCF5250 Features

This section provides brief descriptions of the features of the SCF5250 processor.

1.2.1 ColdFire V2 Core

The ColdFire processor Version 2 core consists of two independent, decoupled pipeline structures to maximize performance while minimizing core size. The instruction fetch pipeline (IFP) is a two-stage pipeline for prefetching instructions. The prefetched instruction stream is then gated into the two-stage operand execution pipeline (OEP), which decodes the instruction, fetches the required operands, and then executes the required function. Because the IFP and OEP pipelines are decoupled by an instruction buffer that serves as a FIFO queue, the IFP can prefetch instructions in advance of their actual use by the OEP, which minimizes time stalled waiting for instructions. The OEP is implemented in a two-stage pipeline featuring a traditional RISC data path with a dual-read-ported register file feeding an arithmetic/logic unit (ALU).

1.2.2 DMA Controller

The SCF5250 provides four fully programmable DMA channels for quick data transfer. Single and dual address mode is supported with the ability to program bursting and cycle stealing. Data transfer is selectable as 8, 16, 32, or 128-bits. Packing and unpacking is supported.

Two internal audio channels and the dual UART can be used with the DMA channels. All channels can perform memory to memory transfers. The DMA controller has a user-selectable, 24- or 16-bit counter and a programmable DMA exception handler.

External requests are not supported.

1.2.3 Enhanced Multiply and Accumulate Module (EMAC)

The integrated EMAC unit provides a common set of DSP operations and enhances the integer multiply instructions in the ColdFire architecture. The EMAC provides functionality in three related areas:

1. Faster signed and unsigned integer multiplies
2. New multiply-accumulate operations supporting signed and unsigned operands
3. New miscellaneous register operations

Multiplies of 16x16 and 32x32 with 48-bit accumulates are supported in addition to a full set of extensions for signed and unsigned integers plus signed, fixed-point fractional input operands. The EMAC has a single-clock issue for 32x32-bit multiplication instructions and implements a four-stage execution pipeline.

1.2.4 Instruction Cache

The instruction cache improves system performance by providing cached instructions to the execution unit in a single clock. The SCF5250 processor uses a 8K-byte, direct-mapped instruction cache to achieve 107 MIPS at 120 MHz. The cache is accessed by physical addresses, where each 16-byte line consists of an address tag and a valid bit. The instruction cache also includes a bursting interface for 16-bit and 8-bit port sizes to quickly fill cache lines.

1.2.5 Internal 128-KByte SRAM

The 128-KByte on-chip SRAM is available in two banks, SRAM0 (64K) and SRAM1 (64K). It provides one clock-cycle access for the ColdFire core. This SRAM can store processor stack and critical code or data segments to maximize performance. Memory in SRAM1 can be accessed under DMA.

1.2.6 SDRAM Controller

The SCF5250 SDRAM controller provides a glueless interface for one bank of SDRAM up to 32 MB (256 Mbits). The controller supports a 16-bit data bus. A unique addressing scheme allows for increases in system memory size without rerouting address lines and rewiring boards. The controller operates in page mode, non-page mode, and burst-page mode and supports SDRAMs.

1.2.7 System Interface

The SCF5250 provides a glueless interface to 16-bit port size SRAM, ROM, and peripheral devices with independent programmable control of the assertion and negation of chip-select and write-enable signals.

The SCF5250 also supports bursting ROMs.

1.2.8 External Bus Interface

The bus interface controller transfers information between the ColdFire core or DMA and memory, peripherals, or other devices on the external bus. The external bus interface provides 23 bits of address bus space, a 16-bit data bus, Output Enable, and Read/Write signals. This interface implements an extended synchronous protocol that supports bursting operations.

1.2.9 Serial Audio Interfaces

The SC5250 digital audio interface provides three serial Philips IIS/Sony EIAJ interfaces. One interface is a 4-pin (1 bit clock, 1 word clock, 1 data in, 1 data out), the other two interfaces are 3-pin (1 bit clock, 1 word clock, 1 data in or out). The serial interfaces have no limit on minimum sampling frequency. Maximum sampling frequency is determined by maximum frequency on bit clock input. This is 1/3 the frequency of the internal system clock.

1.2.10 IEC958 Digital Audio Interfaces

The SCF5250 has one digital audio input interface, and one digital audio output interface. The single output carries the consumer “c” channel.

1.2.11 Audio Bus

The audio interfaces connect to an internal bus that carries all audio data. Each receiver places its received data on the audio bus and each transmitter takes data from the audio bus for transmission. Each transmitter has a source select register.

In addition to the audio interfaces, there are six CPU accessible registers connected to the audio bus. Three of these registers allow data reads from the audio bus and allow selection of the audio source. The other three register provide a write path to the audio bus and can be selected by transmitters as the audio source. Through these registers, the CPU has access to the audio samples for processing.

Audio can be routed from a receiver to a transmitter without the data being processed by the core so the audio bus can be used as a digital audio data switch. The audio bus can also be used for audio format conversion.

1.2.12 CD-ROM Encoder/Decoder

The SCF5250 is capable of processing CD-ROM sectors in hardware. Processing is compliant with CD-ROM and CD-ROM XA standards.

The CD-ROM decoder performs following functions in hardware:

- Sector sync recognition
- Descrambling of sectors
- Verification of the CRC checksum for Mode 1, Mode 2 Form 1, and Mode 2 Form 2 sectors
- Third-layer error correction is not performed

The CD-ROM encoder performs following functions in hardware:

- Sector sync recognition
- Scrambling of sectors
- Insertion of the CRC checksum for Mode 1, Mode 2 Form 1, and Mode 2 Form 2 sectors.
- Third-layer error encoding needs to be done in software. This can use approximately 5–10 MHz of performance for single-speed.

1.2.13 Dual UART Module

Two full-duplex UARTs with independent receive and transmit buffers are in this module. Data formats can be 5, 6, 7, or 8 bits with even, odd, or no parity, and up to 2 stop bits in 1/16 increments. Four-byte receive buffers and two-byte transmit buffers minimize CPU service calls. The Dual UART module also provides several error-detection and maskable-interrupt capabilities. Modem support includes request-to-send ($\overline{\text{RTS}}$) and clear-to-send ($\overline{\text{CTS}}$) lines.

The system clock provides the clocking function from a programmable prescaler. You can select full duplex, auto-echo loopback, local loopback, and remote loopback modes. The programmable Dual UARTs can interrupt the CPU on various normal or error-condition events.

1.2.14 Queued Serial Peripheral Interface QSPI

The QSPI module provides a serial peripheral interface with queued transfer capability. It supports up to 16 stacked transfers at a time, making CPU intervention between transfers unnecessary. Transfers of up to 15 Mbits/second are possible at a CPU clock of 120 MHz. The QSPI supports master mode operation only.

1.2.15 Timer Module

The timer module includes two general-purpose timers, each of which contains a free-running 16-bit timer. Timer0 has an external pin TOUT0, which can be used in Output Compare mode. This mode triggers an external signal or interrupts the CPU when the timer reaches a set value, and can also generate waveforms on TOUT0.

The timer unit has an 8-bit prescaler that allows programming of the clock input frequency, which is derived from the system clock. In addition to the $\div 1$ and $\div 16$ clock derived from the bus clock (CPU clock / 2), the programmable timer-output pins either generate an active-low pulse or toggle the outputs.

1.2.16 IDE and SmartMedia Interfaces

The SCF5250 system bus allows connection of an IDE hard disk drive or SmartMedia flash card with a minimum of external hardware. The external hardware consists of bus buffers for address and data and are intended to reduce the load on the bus and prevent SDRAM and Flash accesses to propagate to the IDE bus. The control signals for the buffers are generated in the SCF5250.

Low cost version SCF5250LPV100 and SCF5250LAG100 does not run production test for the IDE/CF/SD/MMC interfaces. Freescale does not guarantee these interfaces will work on these two devices.

1.2.17 Analog/Digital Converter (ADC)

The six channel ADC is based on the Sigma-Delta concept with 12-bit resolution. Both the analogue comparator and digital sections of the ADC are provided internally. An external integrator circuit (resistor/capacitor) is required, which is driven by the ADC output. A software interrupt is provided when the ADC measurement cycle is complete.

1.2.18 I²C Module

The two-wire I²C bus interface, which is compliant with the Philips I²C bus standard, is a bidirectional serial bus that exchanges data between devices. The I²C bus minimizes the interconnection between devices in the end system and is best suited for applications that need occasional bursts of rapid communication over short distances among several devices. Bus capacitance and the number of unique addresses limit the maximum communication length and the number of devices that can be connected.

1.2.19 Chip-Selects

Up to four programmable chip-select outputs provide signals that enable glueless connection to external memory and peripheral circuits. The base address, access permissions and automatic wait-state insertion are programmable with configuration registers. These signals also interface to 16-bit ports.

CS0 is active after reset to provide boot-up from external FLASH/ROM.

1.2.20 GPIO Interface

A total of 60 General Purpose inputs and 57 General Purpose outputs are available. These are multiplexed with various other signals. Seven of the GPIO inputs have edge sensitive interrupt capability.

1.2.21 Interrupt Controller

The interrupt controller provides user-programmable control of a total of 57 interrupts. There are 49 internal interrupt sources. In addition, there are 7 GPIOs where interrupts can be generated on the rising or falling edge of the pin. All interrupts are autovectored and interrupt levels are programmable.

1.2.22 JTAG

To help with system diagnostics and manufacturing testing, the SCF5250 includes dedicated user-accessible test logic that complies with the IEEE 1149.1A standard for boundary scan testability, often referred to as Joint Test Action Group, or JTAG. For more information, refer to the IEEE 1149.1A standard. Freescale provides BSDL files for JTAG testing.

1.2.23 System Debug Interface

The ColdFire processor core debug interface supports real-time instruction trace and debug, plus background-debug mode. A background-debug mode (BDM) interface provides system debug.

In real-time instruction trace, four status lines provide information on processor activity in real time (PST pins). A four-bit wide debug data bus (DDATA) displays operand data and change-of-flow addresses, which helps track the machine's dynamic execution path.

1.2.24 Crystal and On-Chip PLL

Typically, an external 16.92 MHz or 33.86 MHz clock input is used for CD R/W applications, while an 11.2896 MHz clock is more practical for Portable CD player applications. However, the on-chip programmable PLL, which generates the processor clock, allows the use of almost any low frequency external clock (5-35 MHz).

Two clock outputs (MCLK1 and MCLK2) are provided for use as Audio Master Clock. The output frequencies of both outputs are programmable to F_{xtal} , $F_{xtal}/2$, $F_{xtal}/3$, and $F_{xtal}/4$. The $F_{xtal}/3$ option is only available when the 33.86 MHz crystal is connected.

The SCF5250 supports VCO operation of the oscillator by means of a 16-bit pulse density modulation output. Using this mode, it is possible to lock the oscillator to the frequency of an incoming IEC958 or IIS signal. The maximum trim depends on the type and design of the oscillator. Typically a trim of +/- 100 ppm can be achieved with a crystal oscillator and over +/- 1000 ppm with an LC oscillator.

1.2.25 Boot ROM

The boot ROM on the SCF5250 serves to boot the CPU in designs which do not have external Flash memory or ROM. Typically this occurs in systems which have a separate MCU to control the system, and/or the SCF5250 is used as a stand-alone decoder.

The SCF5250 can be booted in one of three modes:

- External ROM
- Internal ROM Master mode – boots from I2C, SPI, or IDE
- Internal ROM Slave mode – boots from I2C or UART

1.2.26 Voltage Regulator

The SCF5250 contains an on-chip linear regulator that generates 1.2V from a 3.3V input. The regulator is self-contained and drives the 1.2V core voltage out on one pin that can be used to power the core supply

pins at the board level. In battery powered portable applications, it is recommended that an external dc-dc converter be used to generate the 1.2V core voltage to minimize power consumption.

2 SCF5250 Block Diagram

Figure 1 illustrates the functional block diagram of the SCF5250 processor.

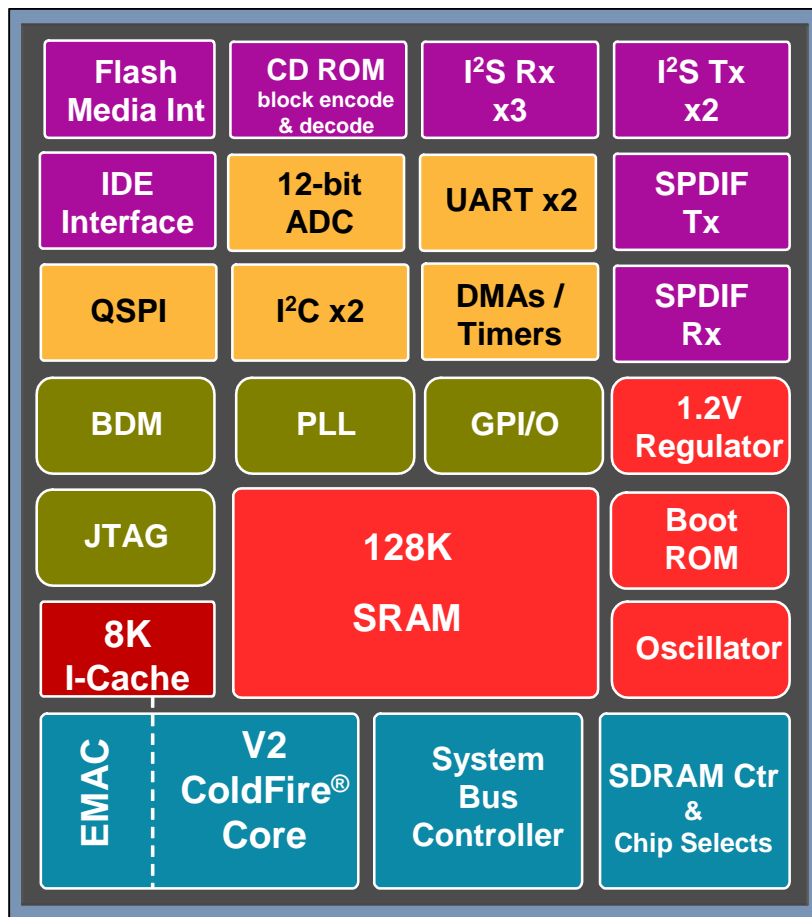

Figure 1. SCF5250 Block Diagram

3 Signal Descriptions

This section describes the SCF5250 processor's input and output signals. The signal descriptions shown in Table 2 are grouped according to relevant functionality.

Table 2. SCF5250 Signal Index

Signal Name	Mnemonic	Function	Input/Output	Reset State
Address	A[24:1] A[23]/GPO54	24 address lines, address line 23 multiplexed with GPO54 and address 24 is multiplexed with A20 (SDRAM access only).	Out	X
Read-write control	R/ \overline{W}	Bus write enable - indicates if read or write cycle in progress	Out	H
Output enable	OE	Output enable for asynchronous memories connected to chip selects	Out	negated
Data	D[31:16]	Data bus used to transfer word data	In/Out	Hi-Z
Synchronous row address strobe	\overline{SDRAS} /GPIO59	Row address strobe for external SDRAM.	Out	negated
Synchronous column address strobe	\overline{SDCAS} /GPIO39	Column address strobe for external SDRAM	Out	negated
SDRAM write enable	\overline{SDWE} /GPIO38	Write enable for external SDRAM	Out	negated
SDRAM upper byte enable	\overline{SDUDQM} /GPO53	Indicates during write cycle if high byte is written	Out	–
SDRAM lower byte enable	\overline{SDLQM} /GPO52	Indicates during write cycle if low byte is written	Out	–
SDRAM chip selects	$\overline{SD_CS0}$ /GPIO60	SDRAM chip select	In/Out	negated
SDRAM clock enable	BCLKE/GPIO63	SDRAM clock enable	Out	–
System clock	BCLK/GPIO40	SDRAM clock output	In/Out	–
ISA bus read strobe	$\overline{IDE-DIOR}$ /GPIO31 (CS2)	There is 1 ISA bus read strobe and 1 ISA bus write strobe. They allow connection of one independent ISA bus peripherals, e.g. an IDE slave device.	In/Out	–
ISA bus write strobe	$\overline{IDE-DIOW}$ /GPIO32 (CS2)		In/Out	–
ISA bus wait signal	$\overline{IDE-IORDY}$ /GPIO33	ISA bus wait line - available for both busses	In/Out	–
Chip Selects[2:0]	$\overline{CS0}/\overline{CS4}$ $\overline{CS1}/\overline{QSPI_CS3}$ /GPIO28	Enables peripherals at programmed addresses. $\overline{CS}[0]$ provides boot ROM selection	Out In/Out	negated
Buffer enable 1	$\overline{BUFENB1}$ /GPIO29	Two programmable buffer enables allow seamless steering of external buffers to split data and address bus in sections.	In/Out	–
Buffer enable 2	$\overline{BUFENB2}$ /GPIO30		In/Out	–
Transfer acknowledge	\overline{TA} /GPIO12	Transfer Acknowledge signal	In/Out	–
Wake Up	$\overline{WAKE_UP}$ /GPIO21	Wake-up signal input	In	–
Serial Clock Line	SCL0/SDATA1_BS1/GPIO41 SCL1/TXD1/GPIO10	Clock signal for Dual I ² C module operation	In/Out	–
Serial Data Line	SDA0/SDATA3/GPIO42 SDA1/RXD1/GPIO44	Serial data port for second I ² C module operation	In/Out	–
Receive Data	SDA1/RXD1/GPIO44 RXD0/GPIO46	Signal is receive serial data input for DUART	In	–

Table 2. SCF5250 Signal Index (continued)

Signal Name	Mnemonic	Function	Input/Output	Reset State
Transmit Data	SCL1/TXD1/GPIO10 TXD0/GPIO45	Signal is transmit serial data output for DUART	Out	–
Request-To-Send	DDATA3/ $\overline{\text{RTS0}}$ /GPIO4 DDATA1/ $\overline{\text{RTS1}}$ /SDATA2_BS2/GPIO2	DUART signals a ready to receive data query	Out	–
Clear-To-Send	DDATA2/ $\overline{\text{CTS0}}$ /GPIO3 DDATA0/ $\overline{\text{CTS1}}$ /SDATA0_SDIO1/GPIO1	Signals to DUART that data can be transmitted to peripheral	In	–
Timer Output	SDATA01/TOOUT0/GPIO18	Capable of output waveform or pulse generation	Out	–
IEC958 inputs	EBUIN1/GPIO36 EBUIN2/SCLK_OUT/GPIO13 EBUIN3/CMD_SDIO2/GPIO14 QSPI_CS0/EBUIN4/GPIO15	audio interfaces IEC958 inputs	In	–
IEC958 outputs	EBUOUT1/GPIO37 QSPI_CS1/EBUOUT2/GPIO16	audio interfaces IEC958 outputs	Out	–
Serial data in	SDATAI1/GPIO17 SDATAI3/GPIO8	audio interfaces serial data inputs	In	–
Serial data out	SDATA01/TOOUT0/GPIO18 SDATA02/GPIO34	audio interfaces serial data outputs	In/Out Out	–
Word clock	LRCK1/GPIO19 LRCK2/GPIO23 LRCK3/GPIO43/AUDIO_CLOCK	audio interfaces serial word clocks	In/Out	–
Bit clock	SCLK1/GPIO20 SCLK2/GPIO22 SCLK3/GPIO35	audio interfaces serial bit clocks	In/Out	–
Serial input	EF/GPIO6	error flag serial in	In/Out	–
Serial input	CFLG/GPIO5	C-flag serial in	In/Out	–
Subcode clock	RCK/QSPI_DIN/QSPI_DOUT/ GPIO26	audio interfaces subcode clock	In/Out	–
Subcode sync	QSPI_DOUT/SFSY/GPIO27	audio interfaces subcode sync	In/Out	–
Subcode data	QSPI_CLK/SUBR/GPIO25	audio interfaces subcode data	In/Out	–
Clock frequency trim	XTRIM/GPIO0	clock trim control	Out	–
Audio clocks out	MCLK1/GPIO11 QSPI_CS2/MCLK2/GPIO24	DAC output clocks	Out	–
Audio clock in	LRCK3/GPIO43/AUDIO_CLOCK	Optional Audio clock Input	–	–

Table 2. SCF5250 Signal Index (continued)

Signal Name	Mnemonic	Function	Input/Output	Reset State
Memory Stick/ Secure Digital interface	EBUIN3/CMD_SDIO2/GPIO14	Secure Digital command lane Memory Stick interface 2 data I/O	In/Out	–
	EBUIN2/SCLK_OUT/GPIO13	Clock out for both Memory Stick interfaces and for Secure Digital	In/Out	–
	DDATA0/ $\overline{\text{CTS1}}$ /SDATA0_SDIO1/GPIO1	Secure Digital serial data bit 0 Memory Stick interface 1 data I/O	In/Out	–
	SCL0/SDATA1_BS1/GPIO41	Secure Digital serial data bit 1 Memory Stick interface 1 strobe	In/Out	–
	DDATA1/ $\overline{\text{RTS1}}$ /SDATA2_BS2/GPIO2	Secure Digital serial data bit 2 Memory Stick interface 2 strobe Reset output signal	In/Out	–
	SDA0/SDATA3/GPIO42	Secure Digital serial data bit 3	In/Out	–
ADC IN	ADIN0/GPI52 ADIN1/GPI53 ADIN2/GPI54 ADIN3/GPI55 ADIN4/GPI56 ADIN5/GPI57	Analog to Digital converter input signals	In	–
ADC OUT	ADREF ADOUT/SCLK4/GPIO58	Analog to digital convertor output signal. Connect to ADREF via integrator network.	In/Out	–
QSPI clock	QSPI_CLK/SUBR/GPIO25	QSPI clock signal	In/Out	–
QSPI data in	RCK/QSPI_DIN/QSPI_DOUT/GPIO26	QSPI data input	In/Out	–
QSPI data out	RCK/QSPI_DIN/QSPI_DOUT/GPIO26 QSPI_DOUT/SFSY/GPIO27	QSPI data out	In/Out	–
QSPI chip selects	QSPI_CS0/EBUIN4/GPIO15 QSPI_CS1/EBUOUT2/GPIO16 QSPI_CS2/MCLK2/GPIO24 $\overline{\text{CS1}}$ /QSPI_CS3/GPIO28	QSPI chip selects	In/Out	–
Crystal in	CRIN	Crystal input	In	–
Crystal out	CROUT	Crystal Out	Out	–
Reset In	RSTI	Processor Reset Input	In	–
Freescale Test Mode	TEST[2:0]	TEST pins.	In	–
Linear regulator output	LINOUT	outputs 1.2 V to supply core	Out	–
Linear regulator input	LININ	Input, typically I/O supply (3.3V)	In	–
Linear regulator ground	LINGND	–	–	–
High Impedance	HI-Z	Assertion Tri-states all output signal pins.	In	–
Debug Data	DDATA0/ $\overline{\text{CTS1}}$ /SDATA0_SDIO1/GPIO1 DDATA1/ $\overline{\text{RTS1}}$ /SDATA2_BS2/GPIO2 DDATA2/ $\overline{\text{CTS0}}$ /GPIO3 DDATA3/ $\overline{\text{RTS0}}$ /GPIO4	Displays captured processor data and break-point status.	In/Out	Hi-Z

Table 2. SCF5250 Signal Index (continued)

Signal Name	Mnemonic	Function	Input/Output	Reset State
Processor Status	PST0/GPIO50 PST1/GPIO49 PST2/INTMON2/GPIO48 PST3/INTMON1/GPIO47	Indicates internal processor status.	In/Out	Hi-Z
Processor Clock	PSTCLK/GPIO51	processor clock output	Out	–
Test Clock	TCK	Clock signal for IEEE 1149.1A JTAG.	In	–
Test Reset/Development Serial Clock	TRST/DSCLK	Multiplexed signal that is asynchronous reset for JTAG controller. Clock input for debug module.	In	–
Test Mode Select/ Break Point	TMS/BKPT	Multiplexed signal that is test mode select in JTAG mode and a hardware break-point in debug mode.	In	–
Test Data Input / Development Serial Input	TDI/DSI	Multiplexed serial input for the JTAG or background debug module.	In	–
Test Data Output/Development Serial Output	TDO/DSO	Multiplexed serial output for the JTAG or background debug module.	Out	–

3.1 GPIO

Many pins have an optional GPIO function.

- General purpose input is always active, regardless of state of pin.
- General purpose output or primary output is determined by the appropriate setting of the Pin Multiplex Control Registers, GPIO-FUNCTION, GPIO1-FUNCTION and PIN-CONFIG.
- At Power-on reset, all pins are set to their primary function.

3.2 SCF5250 Bus Signals

These signals provide the external bus interface to the SCF5250 processor.

3.2.1 Address Bus

- The address bus provides the address of the byte or most significant byte of the word or longword being transferred. The address lines also serve as the DRAM address pins, providing multiplexed row and column address signals.
- Bits 23 down to 1 and 24 of the address are available. A24 is intended to be used with 256 Mbit DRAM's. Signals are named:
 - A[23:1]
 - A20/24

3.2.2 Read-Write Control

This signal indicates during any bus cycle whether a read or write is in progress. A low is write cycle and a high is a read cycle.

3.2.3 Output Enable

The \overline{OE} signal is intended to be connected to the output enable of asynchronous memories connected to chip selects. During bus read cycles, the ColdFire processor will drive \overline{OE} low.

3.2.4 Data Bus

The data bus (D[31:16]) is bi-directional and non-multiplexed. Data is registered by the SCF5250 on the rising clock edge. The data bus uses a default configuration if none of the chip-selects or DRAM bank match the address decode. All 16 bits of the data bus are driven during writes, regardless of port width or operand size.

3.2.5 Transfer Acknowledge

The \overline{TA} /GPIO12 pin is the transfer acknowledge signal.

3.3 SDRAM Controller Signals

The following SDRAM signals provide a glueless interface to external SDRAM. An SDRAM width of 16 bits is supported and can access as much as 32MB of memory. ADRAMs are not supported.

Table 3. SDRAM Controller Signals

SDRAM Signal	Description
Synchronous DRAM row address strobe	The \overline{SDRAS} /GPIO59 active low pin provides a seamless interface to the RAS input on synchronous DRAM
Synchronous DRAM Column Address Strobe	The \overline{SDCAS} /GPIO39 active low pin provides a seamless interface to CAS input on synchronous DRAM.
Synchronous DRAM Write	The \overline{SDWE} /GPIO38 active-low pin is asserted to signify that a SDRAM write cycle is underway. This pin outputs logic '1' during read bus cycles.
Synchronous DRAM Chip Enable	The $\overline{SD_CS0}$ /GPIO60 active-low output signal is used during synchronous mode to route directly to the chip select of a SDRAM device.
Synchronous DRAM UDMQ and LQDM signals	The DRAM byte enables UDMQ and LDQM are driven by the SDUDQM/GPO53 and SDLDQM/GPO52 byte enable outputs.
Synchronous DRAM clock	The DRAM clock is driven by the BCLK/GPIO40 signal
Synchronous DRAM Clock Enable	The BCLKE active high output signal is used during synchronous mode to route directly to the SCKE signal of external SDRAMs. This signal provides the clock enable to the SDRAM.

3.4 Chip Selects

There are three chip select outputs on the SCF5250 device. $\overline{CS0/CS4}$ and $\overline{CS1/QSPI_CS3}/GPIO28$ and CS2 which is associated with the IDE interface read and write strobes - IDE-DIOR and IDE-DIOW.

CS0 and CS4 are multiplexed. The SCF5250 has the option to boot from an internal Boot ROM. The function of the CS0/CS4 pin is determined by the boot mode. When the device is booted from internal ROM, the internal ROM is accessed with CS0 (required for boot) and the CS0/CS4 pin is driven by CS4. When the device is booted from external ROM / Flash, the CS0/CS4 pin is driven by CS0 and the internal ROM is disabled.

The active low chip selects can be used to access asynchronous memories. The interface is glueless.

3.5 ISA Bus

The SCF5250 supports an ISA bus. Using the ISA bus protocol, reads and writes for one ISA bus peripheral is possible. $\overline{IDE-DIOR}/GPIO31$ and $\overline{IDE-DIOW}/GPIO32$ are the read and write strobe. The peripheral can insert wait states by pulling IDE-IORDY/GPIO33.

CS2 is associated with the IDE-DIOR and IDE-DIOW.

3.6 Bus Buffer Signals

As the SCF5250 has a complicated slave bus, which allows SDRAM, asynchronous memories, and ISA peripherals on the bus, it may become necessary to introduce a buffer on the bus in certain applications. The SCF5250 has a glueless interface to steer these bus buffers with two bus buffer output signals $\overline{BUFENB1}/GPIO29$ and $\overline{BUFENB2}/GPIO30$.

3.7 I²C Module Signals

There are two I²C interfaces on this device as described in [Table 4](#).

The I²C module acts as a two-wire, bidirectional serial interface between the SCF5250 processor and peripherals with an I²C interface (e.g., LED controller, A-to-D converter, D-to-A converter). When devices connected to the I²C bus drive the bus, they will either drive logic-0 or high-impedance. This can be accomplished with an open-drain output.

Table 4. I²C Module Signals

I ² c Module Signal	Description
I ² C Serial Clock	The SCL0/SDATA1_BS1/GPIO41 and SCL1/TXD1/GPIO10 bidirectional signals are the clock signal for first and second I ² C module operation. The I ² C module controls this signal when the bus is in master mode; all I ² C devices drive this signal to synchronize I ² C timing. Signals are multiplexed
I ² C Serial Data	The SDA0/SDATA3/GPIO42 and SDA1/RXD1/GPIO44 bidirectional signals are the data input/output for the first and second serial I ² C interface. Signals are multiplexed

3.8 Serial Module Signals

The signals described in [Table 5](#) transfer serial data between the two UART modules and the external peripherals.

Table 5. Serial Module Signals

Serial Module Signal	Description
Receive Data	The RXD0/GPIO46 and SDA1/RXD1/GPIO44 are the inputs on which serial data is received by the DUART. Data is sampled on RxD[1:0] on the rising edge of the serial clock source, with the least significant bit received first.
Transmit Data	The DUART transmits serial data on the TXD0/GPIO45 and SCL1/TXD1/GPIO10 output signals. Data is transmitted on the falling edge of the serial clock source, with the least significant bit transmitted (LSB) first. When no data is being transmitted or the transmitter is disabled, these two signals are held high. TxD[1:0] are also held high in local loopback mode.
Request To Send	The DDATA3/RTS0/GP104 and DDATA1/RTS1/SDATA2_BS2/GPIO2 request-to-send outputs indicate to the peripheral device that the DUART is ready to send data and requires a clear-to-send signal to initiate transfer.
Clear To Send	Peripherals drive the DDATA2/CTS0/GPIO3 and DDATA0/CTS1/SDATA0_SDIO1/GPIO1 inputs to indicate to the SCF5250 serial module that it can begin data transmission.

3.9 Timer Module Signals

[Table 6](#) describes the Timer module signal which provides an external interface to Timer0.

Table 6. Timer Module Signals

Serial Module Signal	Description
Timer Output	The SDATAO1/TOUT0/GPIO18 programmable output pulse or toggle on various timer events.

3.10 Serial Audio Interface Signals

Table 7 describes the signals that provide the external audio interface.

Table 7. Serial Audio Interface Signals

Serial Module Signal	Description
Serial Audio Bit Clock	The SCLK1/GPIO20, SCLK2/GPIO22 and SCLK3/GPIO35, multiplexed pins can serve as general purpose I/Os or serial audio bit clocks. As bit clocks, these bidirectional pins can be programmed as outputs to drive their associated serial audio (IIS) bit clocks. Alternately, these pins can be programmed as inputs when the serial audio bit clocks are driven internally. The functionality is programmed within the Audio module. During reset, these pins are configured as input serial audio bit clocks.
Serial Audio Word Clock	The LRCK1/GPIO19, LRCK2/GPIO23 and LRCK3/GPIO43/AUDIO_CLOCK multiplexed pins can serve as general purpose I/Os or serial audio word clocks. As word clocks, the bidirectional pins can be programmed as inputs to drive their associated serial audio word clock. Alternately, these pins can be programmed as outputs when the serial audio word clocks are derived internally. The functionality is programmed within the Audio module. During reset, these pins are configured as input serial audio word clocks. LRCK3/GPIO43/AUDIO_CLOCK can be used as the external audio clock input. If the core clock chosen to be non-audio specific.
Serial Audio Data In	The SDATA11/GPIO17 and SDATA13/GPIO8 multiplexed pins can serve as general purpose I/Os or serial audio inputs. As serial audio inputs the data is sent to interfaces 1 and 3 respectively. During reset, the pins are configured as serial data inputs.
Serial Audio Data Out	SDATO1/TOUT0/GPIO18 AND SDATAO2/GPIO34 multiplexed pins can serve as general purpose I/Os or serial audio outputs. During reset, the pins are configured as serial data outputs.
Serial audio error flag	The EF/GPIO6 multiplexed pin can serve as general purpose I/Os or error flag input. As error flag input, this pin will input the error flag delivered by the CD-DSP. EF/GPIO6 is only relevant for serial interface SDATA11.
Serial audio CFLG	The CFLG/GPIO5 multiplexed pin can serve as general purpose I/O or CFLG input. As CFLG input, the pin will input the CFLG flag delivered by the CD-DSP. CFLG/GPIO5 is only relevant for serial interface SDATA11.

3.11 Digital Audio Interface Signals

Table 8 describes the signals for the digital audio interface.

Table 8. Digital Audio Interface Signals

Serial Module Signal	Description
Digital Audio In	The EBUIN1/GPIO36, EBUIN2/SCLK_OUT/GPIO13, EBUIN3/CMD_SDIO2/GPIO14, and QSPI_CS0/EBUIN4/GPIO15 multiplexed signals can serve as general purpose input or can be driven by various digital audio (IEC958) input sources. Both functions are always active. Input chosen for IEC958 receiver is programmed within the audio module. Input value on the 4 pins can always be read from the appropriate GPIO register.
Digital Audio Out	The EBUOUT1/GPIO37 and QSPI_CS1/EBUOUT2/GPIO16 multiplexed pins can serve as general purpose I/O or as digital audio (IEC958) output. EBUOUT1 is digital audio out for consumer mode, EBUOUT2 is digital audio out for professional mode. During reset, the pin is configured as a digital audio output.

3.12 Subcode Interface

There is a 3-line subcode interface on the SCF5250 processor. This 3-line subcode interface allows the device to format and transmit subcode in EIAJ format to a CD channel encoder device. The three signals are described in [Table 9](#).

Table 9. Subcode Interface Signal

Signal name	Description
RCK/QSPI_DIN/QSPI_DOUT/GPIO26	Subcode clock input. When pin is used as subcode clock, this pin is driven by the CD channel encoder.
QSPI_DOUT/SFSY/GPIO27	Subcode sync output This signal is driven high if a subcode sync needs to be inserted in the EFM stream.
QSPI_CLK/SUBR/GPIO25	Subcode data output This signal is a subcode data out pin.

3.13 Analog to Digital Converter (ADC)

The ADOUT signal on the ADOUT/SCLK4/GPIO58 pin provides the reference voltage in PWM format. This output requires an external integrator circuit (resistor/capacitor) to convert it to a DC level to be input to the ADREF pin.

The six AD inputs are each fed to their own comparator. The reference input to each (ADREF) is then multiplexed as only one AD comparison can be made at any one time.

NOTE

To use the ADIN_x as General Purpose inputs (rather than their analogue function) it is necessary to generate a fixed comparator voltage level of VDD/2. This can be accomplished by a potential divider network connected to the ADREF pin. However in portable applications where stand-by power consumption is important the current taken by the divider network (in stand-by mode) could be excessive. Therefore it is possible to generate a VDD/2 voltage by selecting SCLK4 output mode and feeding this clock signal (which is 50% duty cycle) through an external integration circuit. This would generate a voltage level equal to VDD/2 but would be disabled when stand-by mode was selected.

3.14 Secure Digital/Memory Stick Card Interface

The device has a versatile flash card interface that supports both Secure Digital and Memory Stick cards. The interface can either support one Secure Digital or two Memory Stick cards. No mixing of card types is possible. [Table 10](#) gives the pin descriptions.

Table 10. Flash Memory Card Signals

Flash Memory Signal	Description
EBUIN2/SCLKOUT/GPIO13	Clock out for both Memory Stick interfaces and for Secure Digital
EBUIN3/CMD_SDIO2/GPIO14	Secure Digital command line Memory Stick interface 2 data I/O

Table 10. Flash Memory Card Signals (continued)

Flash Memory Signal	Description
DDATA0/ $\overline{\text{CTS1}}$ /SDATA0_SDIO1/GPIO1	Secure Digital serial data bit 0 Memory Stick interface 1 data I/O
SCL0/SDATA1_BS1/GPIO41	Secure Digital serial data bit 1 Memory Stick interface 1 strobe
DDATA1/ $\overline{\text{RTS1}}$ /SDATA2_BS2/GPIO2	Secure Digital serial data bit 2 Memory Stick interface 2 strobe Reset output signal Selection between Reset function and SDATA2_BS2 is done by programming PLLCR register.
SDA0/SDATA3/GPIO42	Secure Digital serial data bit 3

3.15 Queued Serial Peripheral Interface (QSPI)

The QSPI interface is a high-speed serial interface allowing transmit and receive of serial data. Pin descriptions are given in [Table 11](#).

Table 11. Queued Serial Peripheral Interface (QSPI) Signals

Serial Module Signal	Description
QSPICLK/SUBR/GPIO25	Multiplexed signal IIC interface clock or QSPI clock output Function select is done via PLLCR register.
RCK/QSPIDIN/QSPI_DOUT/GPIO26	Multiplexed signal IIC interface data or QSPI data input. Function select is done via PLLCR register.
RCK/QSPI_DIN/QSPI_DOUT/GPIO26 QSPI_DOUT/SFSY/GPIO27	QSPI data output.
QSPICS0/EBUIN4/GPIO15	4 different QSPI chip selects.
QSPICS1/EBUOUT2/GPIO16	
QSPICS2/MCLK2/GPIO24	
CS1/QSPICS3/GPIO28	

3.16 Crystal Trim

The XTRIM/GPIO0 output produces a pulse-density modulated phase/frequency difference signal to be used after low-pass filtering to control varicap-voltage to control crystal oscillation frequency. This will lock the crystal to the incoming digital audio signal.

3.17 Clock Out

The MCLK1/GPIO11 and QSPI_CS2/MCLK2/GPIO24 can serve as DAC clock outputs. When programmed as DAC clock outputs, these signals are directly derived from the crystal oscillator or clock Input (CRIN).

3.18 Debug and Test Signals

These signals interface with external I/O to provide processor debug and status signals.

3.18.1 Test Mode

The TEST[2:0] inputs are used for various manufacturing and debug tests. For normal mode TEST [2:1] should be ways be tied low. TEST0 should be set high for BDM debug mode and set low for JTAG mode.

3.18.2 High Impedance

The assertion of $\overline{\text{HI_Z}}$ will force all output drivers to a high-impedance state. The timing on $\overline{\text{HI_Z}}$ is independent of the clock.

NOTE

JTAG operation will override the $\overline{\text{HI_Z}}$ pin.

3.18.3 Processor Clock Output

The internal PLL generates this PSTCLK/GPIO51 and output signal, and is the processor clock output that is used as the timing reference for the Debug bus timing (DDATA[3:0] and PST[3:0]). The PSTCLK/GPIO51 is at the same frequency as the core processor.

3.18.4 Debug Data

The debug data pins, DDATA0/CTS1/SDATA0_SDIO1/GPIO1, DDATA1/RTS1/SDATA2_BS2/GPIO2, DDATA2/CTS0/GPIO3, and DDATA3/RTS0/GPIO4, are four bits wide. This nibble-wide bus displays captured processor data and break-point status.

3.18.5 Processor Status

The processor status pins, PST0/GPIO50, PST1/GPIO49, PST2/INTMON/GPIO48, and PST3/INTMON/GPIO47, indicate the SCF5250 processor status. During debug mode, the timing is synchronous with the processor clock (PSTCLK) and the status is not related to the current bus transfer. [Table 12](#) shows the encodings of these signals.

Table 12. Processor Status Signal Encodings

PST[3:0]		Definition
(HEX)	(BINARY)	
\$0	0000	Continue execution
\$1	0001	Begin execution of an instruction
\$2	0010	Reserved
\$3	0011	Entry into user-mode
\$4	0100	Begin execution of PULSE and WDDATA instructions
\$5	0101	Begin execution of taken branch or Synch_PC ¹
\$6	0110	Reserved
\$7	0111	Begin execution of RTE instruction
\$8	1000	Begin 1-byte data transfer on DDATA
\$9	1001	Begin 2-byte data transfer on DDATA
\$A	1010	Begin 3-byte data transfer on DDATA
\$B	1011	Begin 4-byte data transfer on DDATA
\$C	1100	Exception processing ²
\$D	1101	Emulator mode entry exception processing ²
\$E	1110	Processor is stopped, waiting for interrupt ²
\$F	1111	Processor is halted ²

¹ Rev. B enhancement.

² These encodings are asserted for multiple cycles.

3.19 BDM/JTAG Signals

The SCF5250 complies with the IEEE 1149.1A JTAG testing standard. The JTAG test pins are multiplexed with background debug pins.

3.20 Clock and Reset Signals

The clock and reset signals configure the SCF5250 processor and provide interface signals to the external system.

3.20.1 Reset In

Asserting $\overline{\text{RSTI}}$ causes the SCF5250 to enter reset exception processing. When $\overline{\text{RSTI}}$ is recognized, the data bus is tri-stated.

3.20.2 Clock Input

SCF5250 includes an on-chip crystal oscillator. The crystal should be connected between CRIN and CROUT. An externally generated clock signal can also be used and should be connected directly to the CRIN pin.

3.21 Wake-Up Signal

To exit power down mode, apply a LOW level to the WAKE_UP/GPIO21 input pin.

3.22 On-Chip Linear Regulator

The SCF5250 includes an on-chip linear regulator. This regulator provides an 1.2 V output which is intended to be used to power the SCF5250 core. Three pins are associated with this function. LININ, LINOUT and LINGND. Typically LININ would be fed by the I/O (PAD) supply (3.3 V) with separate filtering recommended to provide some isolation between the I/O and the core.

In portable solutions this linear regulator may not be efficient enough and in this case we would expect the 1.2 V supply to be generated externally, possibly by a highly efficient DC-DC convertor.

If not used leave pins not connected.

4 Electrical Characteristics

Table 14 through Table 19 provide the electrical characteristics for the SCF5250 processor. The remaining figures and tables in this section provide the timing diagrams and the timing parameters for the SCF5250 processor.

Table 13. Quick Reference for Electrical Characteristics

For	See
Maximum Ratings	Table 14 on page 22
Operating Temperature	Table 15 on page 22
Recommended Operating Supply Voltages	Table 16 on page 22
Linear Regulator Operating Specification	Table 17 on page 23
DC Electrical Specifications	Table 18 on page 23
Operating Parameters for ADC DC Electrical Characteristics	Table 19 on page 24

Table 14. Maximum Ratings

Rating	Symbol	Value	Units
Supply Core Voltage	V_{CC}	-0.5 to +2.5	V
Maximum Core Operating Voltage	V_{CC}	+1.32	V
Minimum Core Operating Voltage	V_{CC}	+1.08	V
Supply I/O Voltage	V_{CC}	-0.5 to +4.6	V
Maximum I/O Operating Voltage	V_{CC}	+3.6	V
Minimum I/O Operating Voltage	V_{CC}	+3.0	V
Input Voltage	V_{in}	-0.5 to +6.0	V
Storage Temperature Range	T_{stg}	-65 to 150	°C

Table 15 provides the recommended operating temperatures for the SCF5250 processor.

Table 15. Operating Temperature

Characteristic	Symbol	Value	Units
Maximum Operating Ambient Temperature	T_{Amax}	85 ¹	°C
Minimum Operating Ambient Temperature	T_{Amin}	-40	°C

¹ This published maximum operating ambient temperature should be used only as a system design guideline. All device operating parameters are guaranteed only when the junction temperature does not exceed 105°C.

Table 16 provides the recommended operating supply voltages for the SCF5250 processor.

Table 16. Recommended Operating Supply Voltages

Pin Name	Min	Typ	Max
CORE-VDD	1.08V	1.2V	1.32V
CORE-VSS	–	gnd	–
PAD-VDD	3.0V	3.3v	3.6V
PAD-VSS	–	gnd	–
ADVDD	3.0V	3.3v	3.6V
ADGND	–	gnd	–
OSCPAD-VDD	3.0V	3.3v	3.6V
OSCPAD-GND	–	gnd	–
PLLCORE1VDD	1.08V	1.2V	1.32V
PLLCORE1GND	–	gnd	–
PLLCORE2VDD	1.08V	1.2v	1.32V
PLLCORE2GND	–	gnd	–
LIN	3.0v	3.3V	3.6V

Table 17 provides the linear regulator operating specifications for the SCF5250 processor.

Table 17. Linear Regulator¹ Operating Specification

Characteristic	Symbol	Min	Typ	Max
Input Voltage	V _{in}	3.0V	3.3V	3.6
Output Voltage (LINOUT)	V _{out}	1.14V	1.2V	1.26V
Output Current	I _{out}	–	100mA	150mA
Power Dissipation	P _d	–	–	436uW
Load Regulation (10% I _{out} ≥ 90% I _{out})	–	40mV	50mV	60mV
Power Supply Rejection	PSRR	–	40dB	–

¹ A pmos regulator is employed as a current source in this Linear regulator, so a 10μF capacitor (ESR 0 ... 5 Ohm) is needed on the output pin (LINOUT) to integrate the current. Typically this will require the use of a Tantalum type capacitor.

Table 18 provides the DC electrical specifications.

Table 18. DC Electrical Specifications (I/O V_{cc} = 3.3 Vdc ± 0.3 Vdc)

Characteristic	Symbol	Min	Max	Units
Operation Voltage Range for I/O	V _{cc}	3.0	3.6	V
Input High Voltage	V _{IH}	2	5.5	V
Input Low Voltage	V _{IL}	-0.3	0.8	V
Input Leakage Current @ 0.0 V /3.3 V During Normal Operation	I _{in}	–	±1	μA
Hi-Impedance (Three-State) Leakage Current @ 0.0 V/3.3 V During Normal Operation	I _{TSL}	–	±1	μA
Output High Voltage I _{OH} = 8mA ¹ , 4mA ² , 2mA ³	V _{OH}	2.4	–	V
Output Low Voltage I _{OL} = 8mA ¹ , 4mA ² , 2mA ³	V _{OL}	–	0.4	V
Schmitt Trigger Low to High Threshold Point ⁶	V _{T+}	1.47	–	V
Schmitt Trigger High to Low Threshold Point ⁶	V _{T-}	–	.95	V
Load Capacitance (DATA[31:16], SCLK[4:1], SCLKOUT, EBUOUT[2:1], LRCK[3:1], SDATA0[2:1], CFLG, EF, DDATA[3:0], PST[3:0], PSTCLK, IDE-DIOR, IDE-DIOW, IORDY)	C _L	–	50	pF
Load Capacitance (ADDR[24:9], BCLK)	C _L	–	40	pF
Load Capacitance (BCLKE, SDCAS, SDRAS, SDLDQM, SD_CS0, SDUDQM, SDWE, BUFENB[2:1])	C _L	–	30	pF
Load Capacitance (SDA0, SDA1, SCL0, SCL1, CMD_SDIO2, SDATA2_BS2, SDATA1_BS1, SDATA0_SDIO1, CS0/CS4, CS1, OE, R/W, TA, TXD[1:0], XTRIM, TDO/DSO, RCK, SFSY, SUBR, SDATA3, TOUT0, QSPID_OUT, QSPICS[3:0], GP[6:5])	C _L	–	20	pF

Table 18. DC Electrical Specifications (I/O Vcc = 3.3 Vdc ± 0.3 Vdc) (continued)

Characteristic	Symbol	Min	Max	Units
Capacitance ⁵ , V _{in} = 0 V, f = 1 MHz	C _{IN}	–	6	pF
DATA[31:16], ADDR[24:9], PSTCLK, BCLK SCL, SDA, PST[3:0], DDATA[3:0], TDSO, SDRAS, SDCAS, SDWE, SD_CS0, SDLDQM, SDUDQM, R/W TOUT0, RTS[1:0], TXD[1:0], SCLK[4:1] BKPT/TMS, DSI/TDI, DSCLK/TRST Capacitance C _{IN} is periodically sampled rather than 100% tested. SCLK[4:1], SCL0, SCL1, SDA0, SDA1, CRIN, RSTI				

Table 19 provides the operating parameters for the ADC DC electrical characteristics.

Table 19. Operating Parameters for ADC DC Electrical Characteristics

Characteristic	Symbol	Min	Typ	Max	Units
Operation Voltage Range for ADC	ADVDD	3	–	3.6	V
Common Mode Rejection	CMR	0	–	ADVDD–1.1	v
Reference Voltage (external)	ADREF	0	–	ADVDD–1.1	v
Input offset voltage	V _{offset}	–	10	–	mV
Input Hysteresis (ADINx = ADVDD/2)	V _{hyst}	0.73	0.78	0.85	mV
ADC Input Linear Operating Range	ADINx	0	–	ADVDD–1.1	V

Figure 2 and Table 20 provide the clock timing diagram and timing parameters.

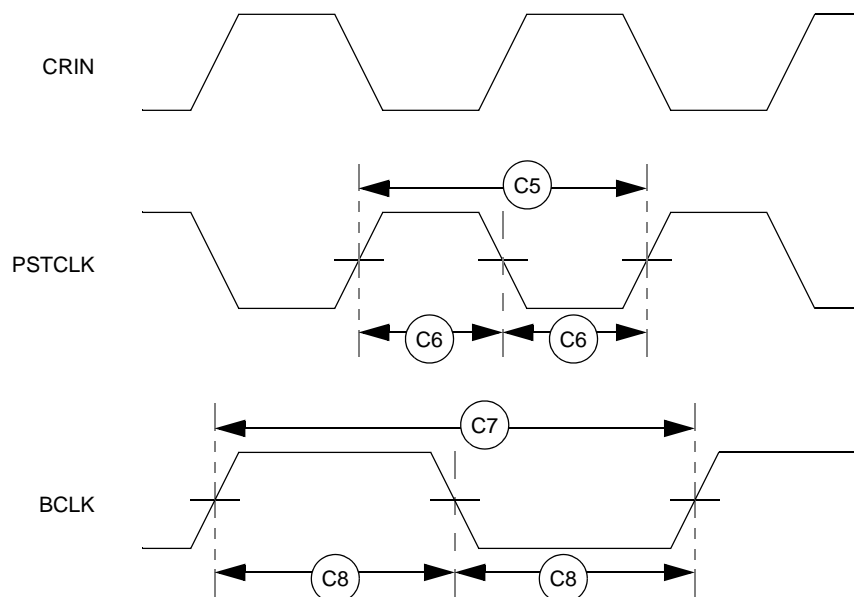

Figure 2. Clock Timing Definition

NOTE

The signals shown in [Figure 2](#) are in relation to the clock. No relationship between signals is implied or intended.

Table 20. Clock Timing Specification

Num	Characteristic	Min	Max	Units
–	CRIN Frequency ¹	5.00	33.86	MHz
C5	PSTCLK cycle time	7.1	–	ns
C6	PSTCLK duty cycle	40	60	%
C7	BCLK cycle time	14.2	–	ns
C8	BCLK duty cycle	45	55	%

¹ There are only three choices for the valid Audio frequencies 11.29 MHz, 16.93 MHz, or 33.86 MHz; no other values are allowed. The System Clock is derived from one of these crystals via an internal PLL.

Figure 3 and Figure 4 provide the input and output AC timing definition diagrams and Table 21 and Table 22 provide the input and output AC timing parameters.

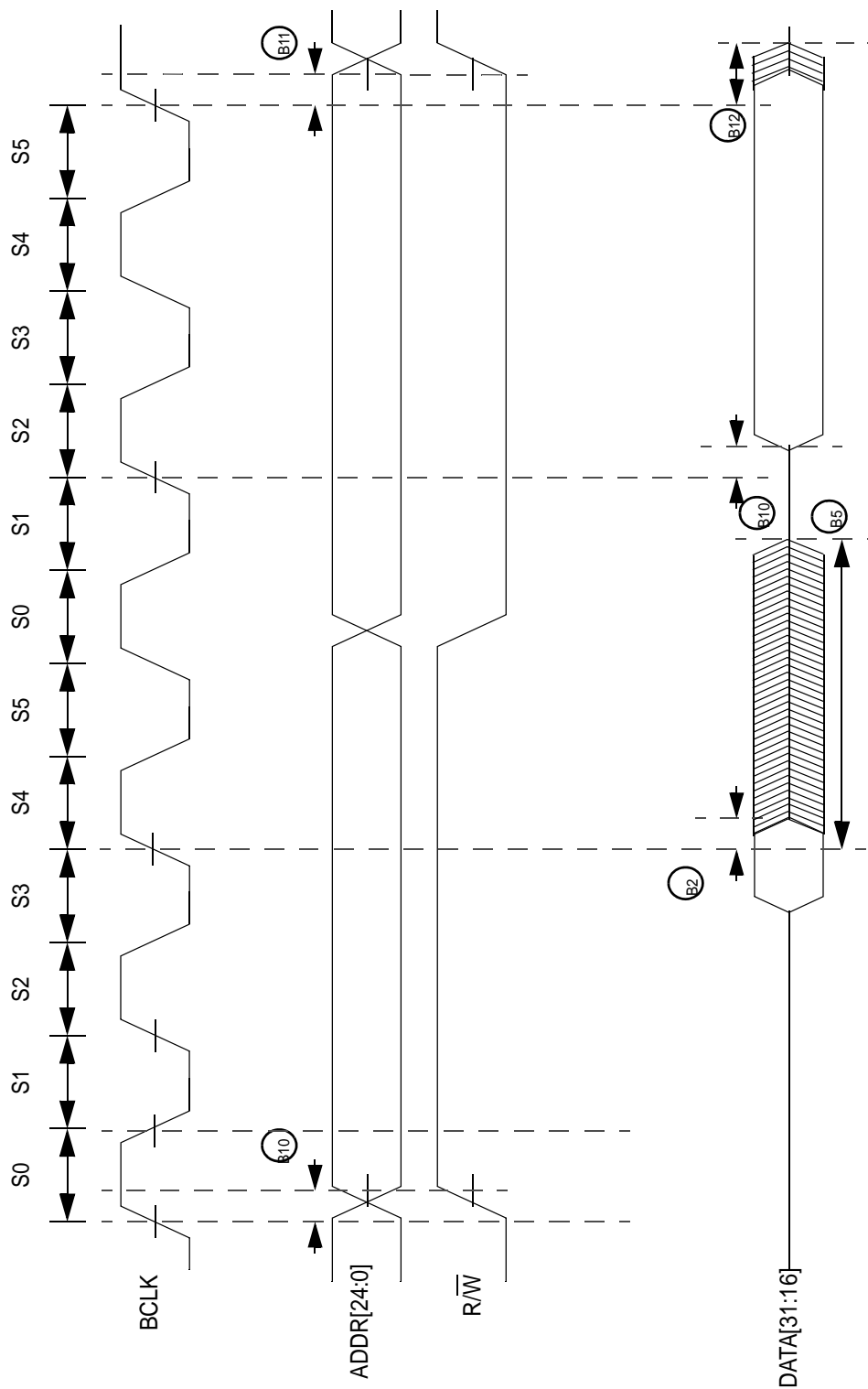

Figure 3. Input/Output Timing Definition-I

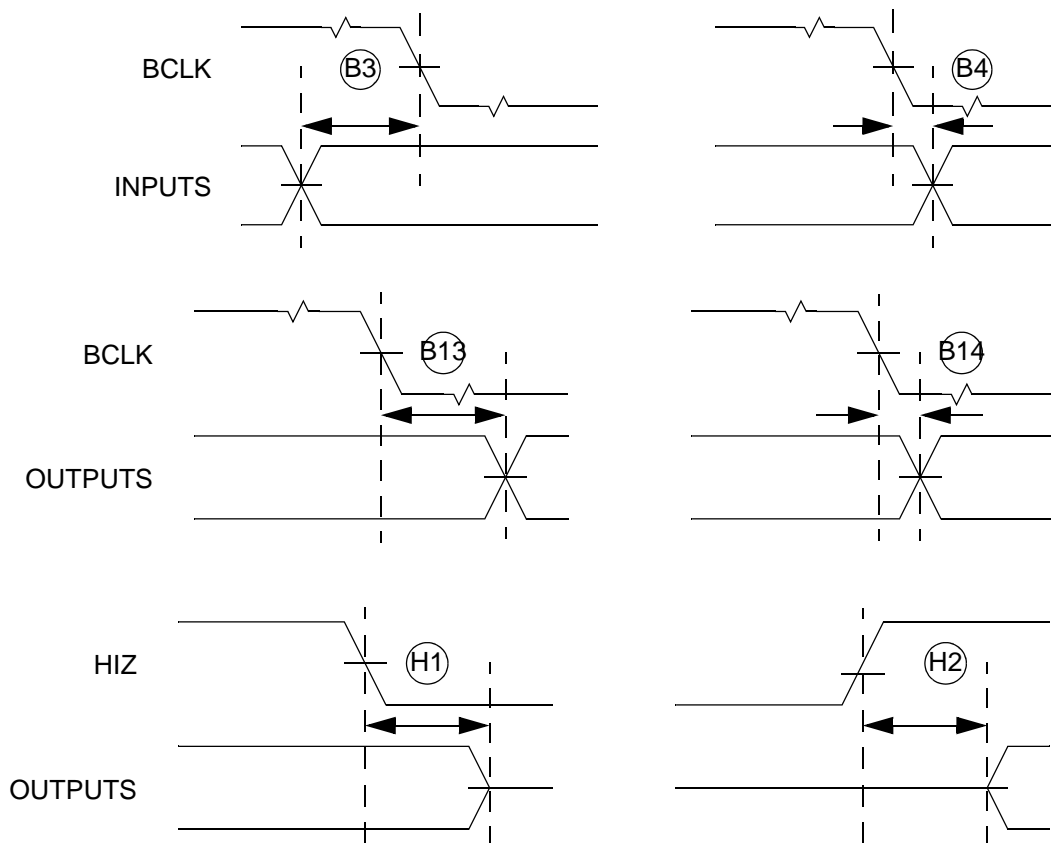

Figure 4. Input/Output AC Timing Definition-III

Table 21. Input AC Timing Specification

Num	Characteristic	Min	Max	Units
B1 ^{1,2}	Signal Valid to BCLK Rising (setup)	3	–	ns
B2 ¹	BCLK Rising to signal Invalid (hold)	2	–	ns
B3 ¹	BCLK to Input High Impedance	–	5	BCLK cycle

¹ Inputs (rising): DATA[31:16]

² AC timing specs assume 40pF load capacitance on BCLK and 50pF load capacitance on output pins. If this value is different, the input and output timing specifications would need to be adjusted to match the clock load.

Table 22. Output AC Timing Specification

Num	Characteristic ¹	Min	Max	Units
B10 ²	BCLK (8mA) Rising to signal Valid	–	10	ns
B11 ²	BCLK (8mA) Rising to signal Invalid (hold)	3.5	–	ns
B10 ³	BCLK (4mA) Rising to signal Valid	–	11	ns
B11 ³	BCLK (4mA) Rising to signal Invalid (hold)	4	–	ns
B12 ⁴	BCLK to High Impedance (Three-State)	–	14	ns

Table 22. Output AC Timing Specification (continued)

Num	Characteristic ¹	Min	Max	Units
H1	$\overline{\text{HIZ}}$ to High Impedance	–	tbd	ns
H2	$\overline{\text{HIZ}}$ to Low Impedance	–	tbd	ns

¹ AC timing specs assume 40pF load capacitance on BCLK and a 50pF load capacitance on output pins. If this value is different, the input and output timing specifications would need to be adjusted to match the clock load.

² Outputs (8mA): DATA[31:16], ADDR[25,23:9]

³ Outputs (4mA): SDRAS, SDCAS, SDWE, SD_CS0, SDUDQM, SDLDQM, BCLKE

⁴ High Impedance (Three-State): DATA[31:16]

Figure 5 and Table 23 provide the timing diagram and timing parameters for the Debug AC.

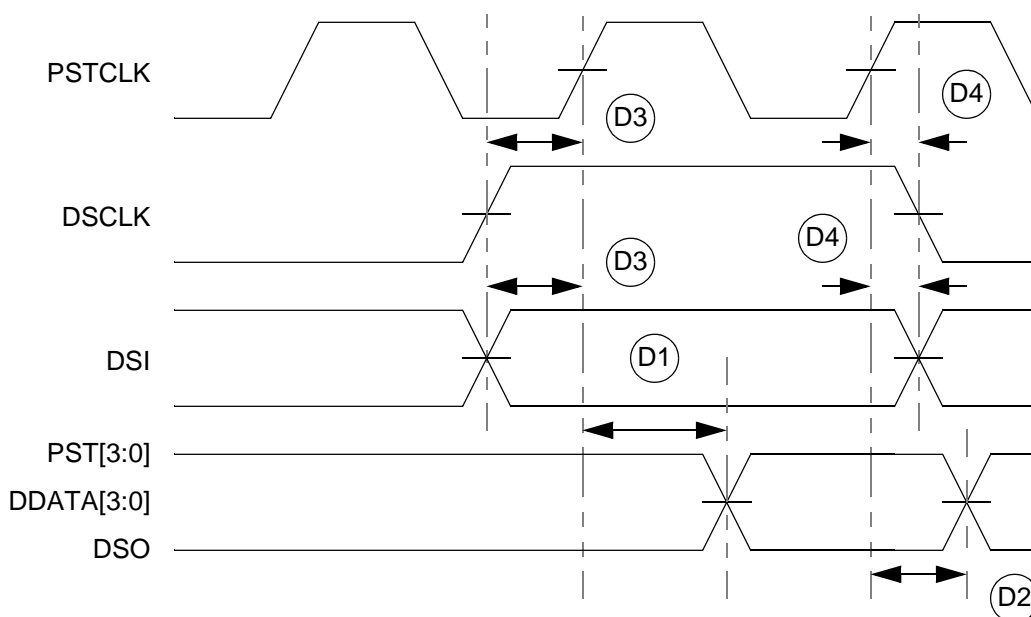

Figure 5. Debug AC Timing Definition Diagram

Table 23. Debug AC Timing Specification¹

Num	Characteristic	Min	Max	Units
D1	PSTCLK to signal Valid (Output valid)	–	6	ns
D2	PSTCLK to signal Invalid (Output hold)	1.8	–	ns
D3 ²	Signal Valid to PSTCLK (Input setup)	3	–	ns
D4	PSTCLK to signal Invalid (Input hold)	5	–	ns

¹ AC timing specs assume 50pF load capacitance on PSTCLK and output pins. If this value is different, the input and output timing specifications would need to be adjusted to match the clock load.

² DSCLK and DSI are internally synchronized. This setup time must be met only if recognition on a particular clock is required.

Figure 6 and Table 24 provide the timing diagram and timing parameters for the Timer module.

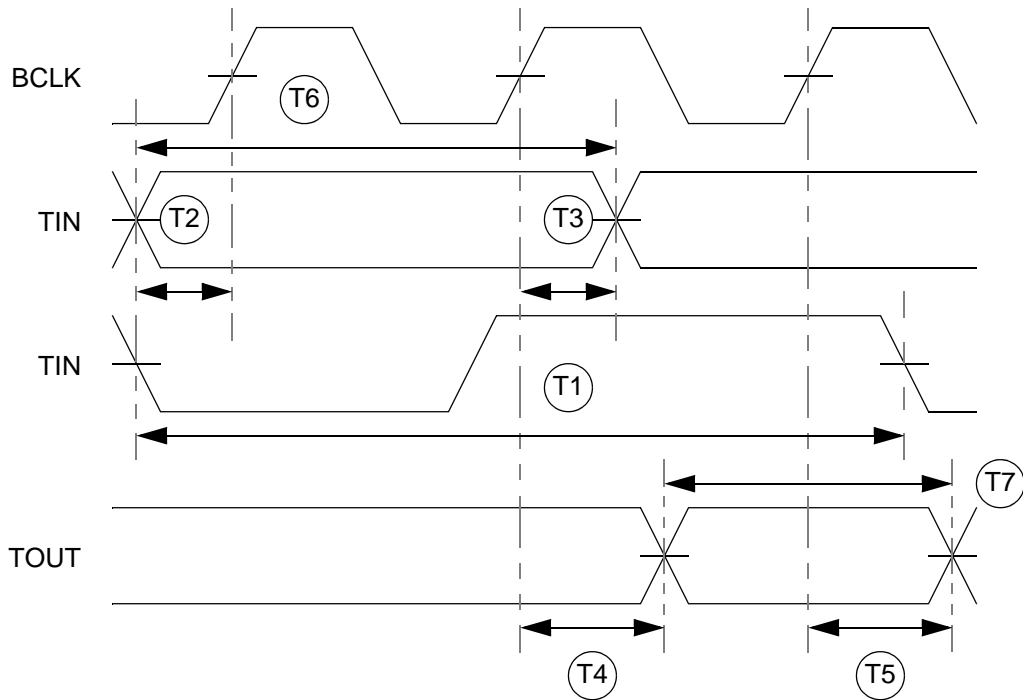

Figure 6. Timer Module AC Timing Definition Diagram

Table 24. Timer Module AC Timing Specification

Num	Characteristic	Min	Max	Units
T1	TIN Cycle time	3T	–	bus clocks
T2	TIN Valid to BCLK (input setup)	6	–	ns
T3	BCLK to TIN Invalid (input hold)	0	–	ns
T4	BCLK to TOUT Valid (output valid)	–	10	ns
T5	BCLK to TOUT Invalid (output hold)	tbd	–	ns
T6	TIN Pulse Width	1T	–	bus clocks
T7	TOUT Pulse Width	1T	–	bus clocks

Figure 7 and Table 25 provide the timing diagram and timing parameters for the UART module.

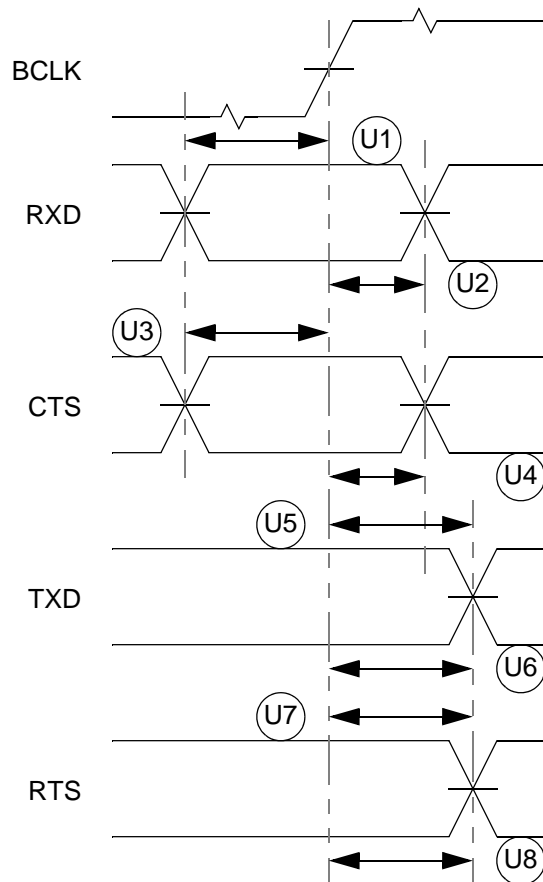

Figure 7. UART Module AC Timing Definition Diagram

Table 25. UART Module AC Timing Specifications

Num	Characteristic	Min	Max	Units
U1	RXD Valid to BCLK (input setup)	6	–	ns
U2	BCLK to RXD Invalid (input hold)	0	–	ns
U3	$\overline{\text{CTS}}$ Valid to BCLK (input setup)	6	–	ns
U4	BCLK to $\overline{\text{CTS}}$ Invalid (input hold)	0	–	ns
U5	BCLK to TXD Valid (output valid)	–	tbd	ns
U6	BCLK to TXD Invalid (output hold)	3	–	ns
U7	BCLK to $\overline{\text{RTS}}$ Valid (output valid)	–	tbd	ns
U8	BCLK to $\overline{\text{RTS}}$ Invalid (output hold)	3	–	ns

Figure 8 provides the I2C-bus input and output timing diagram and Table 26 and Table 27 provide the I2C-bus input and output timing parameters.

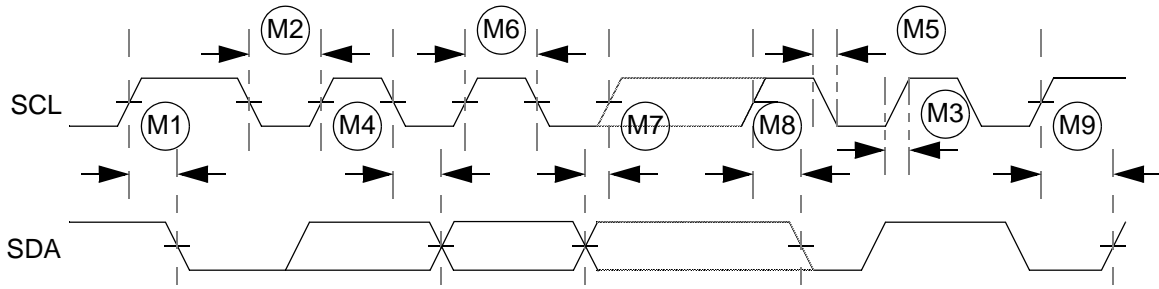

Figure 8. I2C-Bus Input/Output Timing Definition Diagram

Table 26. I2C-Bus Input Timing Specifications Between SCL and SDA

Num	Characteristic	Min	Max	Units
M1	Start Condition Hold Time	2	–	bus clocks
M2	Clock Low Period	8	–	bus clocks
M3	SCL/SDA Rise Time ($V_{IL} = 0.5\text{ V}$ to $V_{IH} = 2.4\text{ V}$)	–	1	mSec
M4	Data Hold Time	0	–	ns
M5	SCL/SDA Fall Time ($V_{IH} = 2.4\text{ V}$ to $V_{IL} = 0.5\text{ V}$)	–	1	ms
M6	Clock High time	4	–	bus clocks
M7	Data Setup Time	0	–	ns
M8	Start Condition Setup Time (for repeated start condition only)	2	–	bus clocks
M9	Stop Condition Setup Time	2	–	bus clocks

Table 27. I2C-Bus Output Timing Specifications Between SCL and SDA

Num	Characteristic	Min	Max	Units
M1 ¹	Start Condition Hold Time	6	–	bus clocks
M2 ¹	Clock Low Period	10	–	bus clocks
M3 ²	SCL/SDA Rise Time ($V_{IL} = 0.5\text{ V}$ to $V_{IH} = 2.4\text{ V}$)	note 2	note 2	mSec
M4 ¹	Data Hold Time	7	–	bus clocks
M5 ³	SCL/SDA Fall Time ($V_{IH} = 2.4\text{ V}$ to $V_{IL} = 0.5\text{ V}$)	–	3	ns
M6 ¹	Clock High time	10	–	bus clocks
M7 ¹	Data Setup Time	2	–	bus clocks
M8 ¹	Start Condition Setup Time (for repeated start condition only)	20	–	bus clocks
M9 ¹	Stop Condition Setup Time	10	–	bus clocks

¹ Output numbers are dependent on the value programmed into the MFDR; an MFDR programmed with the maximum frequency (MFDR = 0x20) will result in minimum output timings as shown. The MBUS interface is designed to scale the actual data transition time to move it to the middle of the SCL low period. The actual position is affected by the prescale and division values programmed into the MFDR; however, numbers given are the minimum values.

² Since SCL and SDA are open-collector-type outputs, which the processor can only actively drive low, the time required for SCL or SDA to reach a high level depends on external signal capacitance and pull-up resistor values.

³ Specified at a nominal 20 pF load.

Figure 9 provides the I2C-bus and system clock timing diagram and Table 28 provides the I2C-bus output timing parameters.

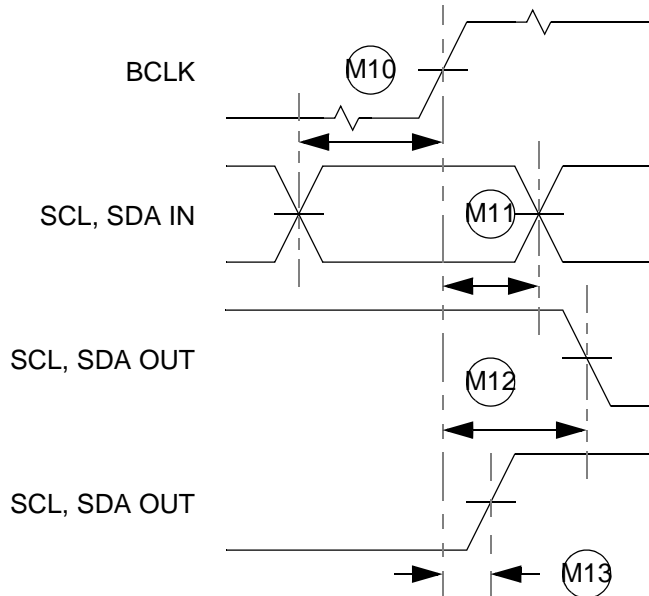

Figure 9. I2C and System Clock Timing Relationship

Table 28. I2C Output Bus Timings

Num	Characteristic	96 MHz		Units
		Min	Max	
M10 ¹	SCL, SDA Valid to BCLK (input setup)	2	–	ns
M11	BCLK to SCL, SDA Invalid (input hold)	4.5	–	ns
M12 ²	BCLK to SCL, SDA Low (output valid)	–	10	ns
M13 ³	BCLK to SCL, SDA Invalid (output hold)	3	–	ns

¹ SCL and SDA are internally synchronized. This setup time must be met only if recognition on a particular clock is required.

² Since SCL and SDA are open-collector-type outputs, which the processor can only actively drive low, this specification applies only when SCL or SDA are driven low by the processor. The time required for SCL or SDA to reach a high level depends on external signal capacitance and pull-up resistor values.

³ Since SCL and SDA are open-collector-type outputs, which the processor can only actively drive low, this specification applies only when SCL or SDA are actively being driven or held low by the processor.

Figure 10 provides the general-purpose parallel port timing diagram and Table 29 provides the timing parameters.

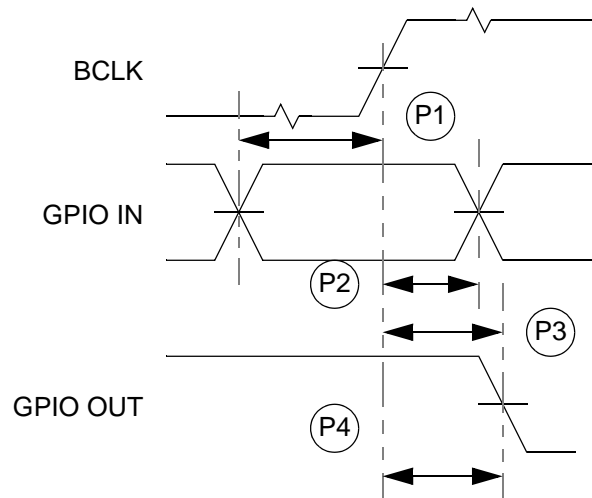

Figure 10. General-Purpose I/O Port AC Timing Definition Diagram

Table 29. General-Purpose I/O Port AC Timing Specifications

Num	Characteristic	Min	Max	Units
P1	GPIO Valid to BCLK (input setup)	6	–	ns
P2	BCLK to GPIO Invalid (input hold)	0	–	ns
P3	BCLK to GPIO Valid (output valid)	–	tbd	ns
P4	BCLK to GPIO Invalid (output hold)	1	–	ns

Figure 11 provides the IEEE 1149.1 JTAG timing diagram and Table 30 provides the timing parameters.

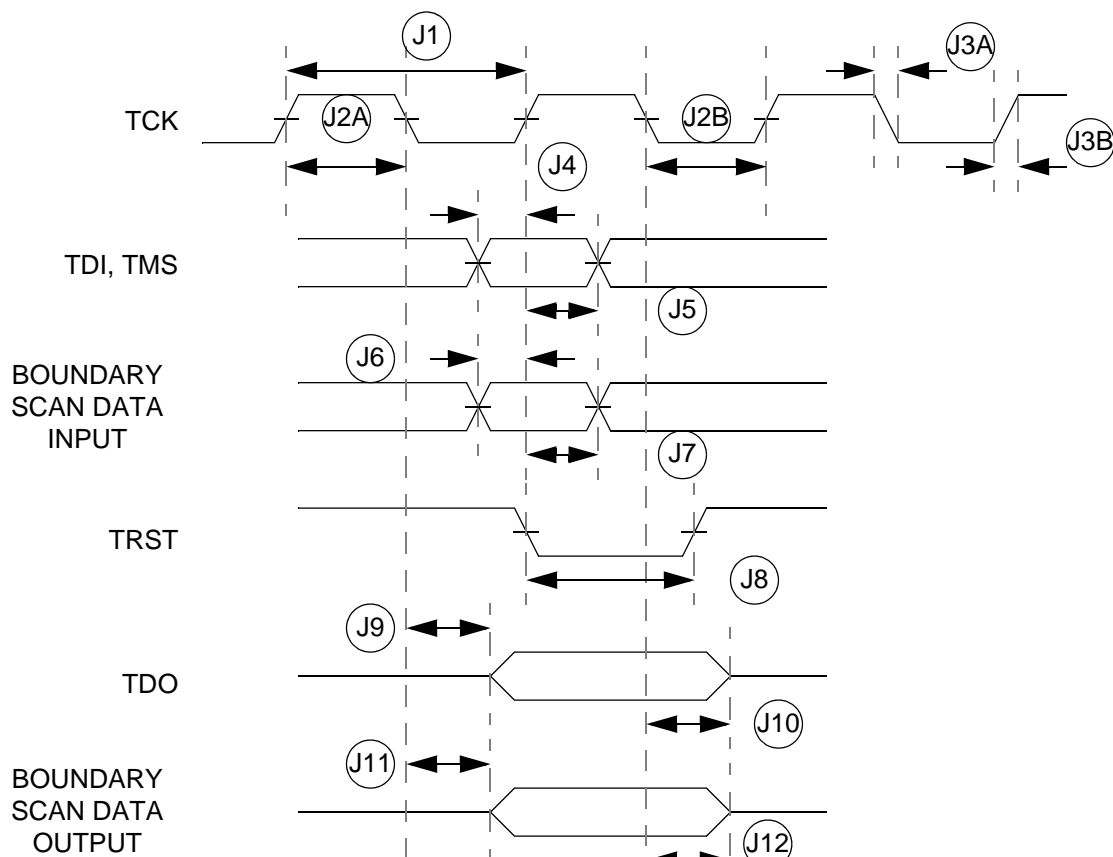

Figure 11. JTAG AC Timing Diagram

Table 30. JTAG AC Timing Specifications

Num	Characteristic	Min	Max	Units
–	TCK Frequency of Operation	0	10	MHz
J1	TCK Cycle Time	100	–	ns
J2a	TCK Clock Pulse High Width	25	–	ns
J2b	TCK Clock Pulse Low Width	25	–	ns
J3a	TCK Fall Time ($V_{IH}=2.4\text{ V}$ to $V_{IL}=0.5\text{ V}$)	–	5	ns
J3b	TCK Rise Time ($V_{IL}=0.5\text{ v}$ to $V_{IH}=2.4\text{ V}$)	–	5	ns
J4	TDI, TMS to TCK rising (Input Setup)	8	–	ns
J5	TCK rising to TDI, TMS Invalid (Hold)	10	–	ns
J6	Boundary Scan Data Valid to TCK (Setup)	tbd	–	ns
J7	TCK to Boundary Scan Data Invalid to rising edge (Hold)	tbd	–	ns
J8	$\overline{\text{TRST}}$ Pulse Width (asynchronous to clock edges)	12	–	ns
J9	TCK falling to TDO Valid (signal from driven or three-state)	–	15	ns
J10	TCK falling to TDO High Impedance	–	15	ns

Table 30. JTAG AC Timing Specifications (continued)

Num	Characteristic	Min	Max	Units
J11	TCK falling to Boundary Scan Data Valid (signal from driven or three-state)	–	tbd	ns
J12	TCK falling to Boundary Scan. Data High Impedance	–	tbd	ns

Figure 12 provides the SCLK input, SDATA output timing diagram for the IIS module and Table 31 provides the timing parameters.

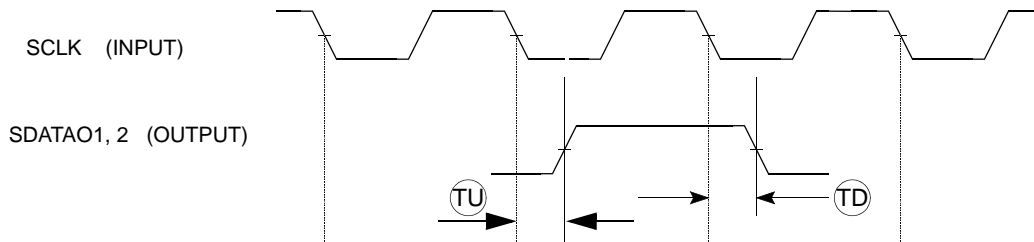

Figure 12. SCLK Input, SDATA Output Timing Diagram

Table 31. SCLK Input, SDATA Output Timing Specifications

Num	Characteristic	Min	Max	Units
TU	SCLK fall to SDATAO rise	–	25	ns
TD	SCLK fall to SDATAO fall	–	25	ns

Figure 13 provides the SCLK output, SDATA output timing diagram for the IIS module and Table 32 provides the timing parameters.

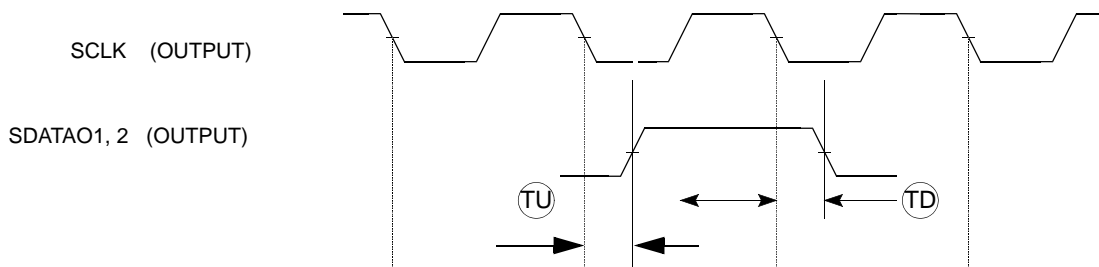

Figure 13. SCLK Output, SDATA Output Timing Diagram

Table 32. SCLK Output, SDATA Output Timing Specifications

Num	Characteristic	Min	Max	Units
TU	SCLK fall to SDATAO rise	–	3	ns
TD	SCLK fall to SDATAO fall	–	3	ns

Figure 14 provides the SCLK input/output, SDATA input timing diagram and Table 33 provides the timing parameters.

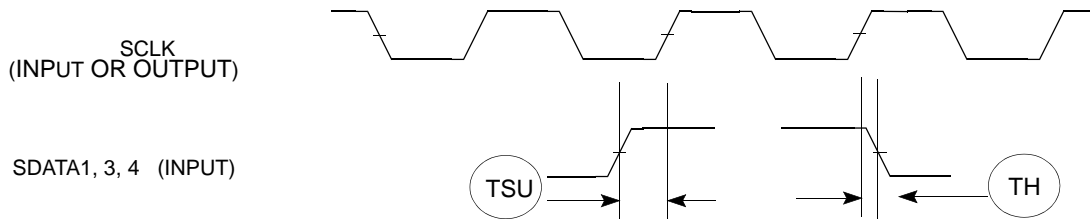

Figure 14. SCLK Input/Output, SDATA Input Timing Diagram

Table 33. SCLK Input/Output, SDATA Input Timing Specifications

Num	Characteristic	Min	Max	Units
TSU	SDATAI IN to SCLKn	-5	–	ns
TH	SCLK rise to SDATAI	3	–	ns

5 Pin-Out and Package Information

Visit the URL [<http://www.freescale.com/coldfire>] and choose the documentation library to obtain information on the mechanical characteristics of the SCF5250 integrated microprocessor. Thermal characteristics are not available at this time.

The SCF5250 is available in a 144 pin QFP and a 196 pin MAPBGA package. Use Table 34 to find the information desired.

Table 34. Section Quick Reference

For Chip Package		See
144 pin QFP	Pin assignments	Table 35 on page 37
	Package drawings	Figure 15 on page 42 Figure 16 on page 43 Figure 17 on page 44
196 MAPBGA	Pin assignments	Table 36 on page 45
	Package drawings	Figure 18 on page 52 Figure 19 on page 53
	Ball map	Figure 20 on page 54

5.1 144 QFP Pin Assignments

The SCF5250 can be assembled in 144-pin QFP package. Table 35 provides the pin assignments for the package.

Table 35. 144 QFP Pin Assignments

144 QFP Pin Number	Name	Type	Description	Pin State After Reset
01	DATA16	I/O	Data	X
02	A23/GPO54	I/O	SDRAM address / static adr	Out (requires pull up /down for boot-up selection)
03	PAD-VDD	–	–	–
04	A22	O	SDRAM address / static adr	Out
05	A21	O	SDRAM address / static adr	Out
06	A20/A24	O	SDRAM address / static adr	Out
07	A19	O	SDRAM address / static adr	Out
08	A18	O	SDRAM address / static adr	Out
09	PAD-GND	–	–	–
10	A17	O	SDRAM address / static adr	Out
11	A16	O	SDRAM address / static adr	Out
12	A15	O	SDRAM address / static adr	Out
13	A14	O	SDRAM address / static adr	Out
14	A13	O	SDRAM address / static adr	Out
15	PAD-VDD	–	–	–
16	A12	O	SDRAM address / static adr	Out
17	A11	O	SDRAM address / static adr	Out
18	CORE-VDD	–	–	–
19	CORE-GND	–	–	–
20	A10	O	SDRAM address / static adr	Out
21	A9	O	SDRAM address / static adr	Out
22	A8	O	SDRAM address / static adr	Out
23	A7	O	SDRAM address / static adr	Out
24	A6	O	SDRAM address / static adr	Out
25	A5	O	SDRAM address / static adr	Out
26	PAD-GND	–	PAD-GND	–
27	A4	O	SDRAM address / static adr	Out
28	A3	O	SDRAM address / static adr	Out
29	A2	O	SDRAM address / static adr	Out
30	A1	O	SDRAM address / static adr	Out
31	CS0/CS4	O	Static chip select 0 / static chip select 4	Out

Table 35. 144 QFP Pin Assignments (continued)

144 QFP Pin Number	Name	Type	Description	Pin State After Reset
32	RW	O	Bus write enable	Out
33	OSC PAD VDD	–	–	–
34	CRIN	I	Crystal / external clock input	X
35	CROUT	O	Crystal clock output	X
36	OSC PAD GND	–	OSC_PAD_GND	–
37	PLL CORE1 VDD	–	–	–
38	PLL CORE2 VDD	–	–	–
39	PLL CORE2 GND	–	–	–
40	PLL CORE1 GND	–	–	–
41	OE	O	Output Enable	Out
42	IDE-DIOW/GPIO32	I/O	IDE DIOW	Out / HIGH
43	IDE-IORDY/GPIO33	I/O	IDE interface IORDY	In / LOW
44	IDE-DIOR/GPIO31	I/O	IDE interface DIOR	Out / HIGH
45	BUFENB2/GPIO30	I/O	External buffer 2 enable	Out / HIGH
46	BUFENB1/GPIO29	I/O	External buffer 1 enable	Out / HIGH
47	TA/GPIO12	I/O	Transfer acknowledge	In (requires pull-up for normal operation)
48	WAKE_UP/GPIO21	I/O	Wake-up input	In (requires pull-up for normal operation)
49	EBUIN2/SCLK_OUT/ GPIO13	I/O	Audio interfaces EBU in 2 / FlashMedia Clock	In / LOW
50	EBUIN3/CMD_SDIO2/ GPIO14	I/O	Audio interfaces EBU in 3 / FlashMedia Command interface	In / LOW
51	PAD VDD	–	–	–
52	EBUIN1/GPIO36	I/O	Audio interfaces EBU in 1	In / LOW
53	EBUOUT1/GPIO37	I/O	Audio interfaces EBU out 1	Out / LOW
54	XTRIM/GPIO0	I/O	Audio interfaces X-tal trim	Out / clock out
55	CS1/QSPI_CS3/GPIO28	I/O	Chip select 1/ QSPI Chip Select 3	Out / HIGH
56	RCK/ QSPI_DIN/QSPI_DOUT/ GPIO26	I/O	Subcode RCK interface / QSPI Data In / Data Out	Out / LOW
57	QSPI_CLK/SUBR/GPIO25	I/O	QSPI clock pin / subcode interface	Out / LOW
58	QSPI_DOUT/SFSY/ GPIO27	I/O	QSPI Data Output / subcode interface SFSY	Out / LOW

Table 35. 144 QFP Pin Assignments (continued)

144 QFP Pin Number	Name	Type	Description	Pin State After Reset
59	QSPI_CS1/EBUOUT2/ GPIO16	I/O	QSPI Chip select 1 output / audio interface EBU output 2	Out / LOW
60	QSPI_CS0/EBUIN4/ GPIO15	I/O	QSPI chip select 0 / audio interface EBUIN 4	Out / LOW
61	PAD GND	–	–	–
62	SCLK1/GPIO20	I/O	Audio interfaces serial clock 1	In / LOW
63	LRCK1/GPIO19	I/O	Audio interfaces word clock 1	In / LOW
64	SDATAO1/TOUT0/ GPIO18	I/O	Audio interfaces serial data output 1 / Timer output 0	Out / LOW
65	SDATAI1/GPIO17	I	Audio interfaces serial data in 1	In / LOW
66	CFLG/GPIO5	I/O	CFLG input	In / LOW
67	EF/GPIO6	I/O	Error flag input	In / LOW
68	QSPI_CS2/MCLK2/ GPIO24	I/O	QSPI Chip Select output 2 / audio master clock output 2	Out / LOW
69	SDATAI3/GPIO8	I/O	Audio interfaces serial data input 3	In / LOW
70	ADIN0/GPI52	A	AD input 0	In only
71	ADIN1/GPI53	A	AD input 1	In only
72	ADIN2/GPI54	A	AD input 2	In only
73	ADVDD	–	–	–
74	ADGND	–	–	–
75	ADIN3/GPI55	A	AD input 3	In only
76	ADIN4/GPI56	A	AD input 4	In only
77	ADIN5/GPI57	A	AD input 5	In only
78	ADREF	A	ADC reference input	In
79	ADOUT/SCLK4/ GPIO58	I/O	AD output / SCLK4 (for GPI function in low power applications)	Out / clock output
80	LRCK3/GPIO43/ AUDIO_CLOCK	I/O	Audio interface LRCK3 / Audio master clock input	In / LOW
81	SCLK3/GPIO35	I/O	Audio interface SCLK3	In / LOW
82	SCL0/SDATA1_BS1/ GPIO41	I/O	I2C0 clock line / FlashMedia Data interface	Out / LOW
83	SDA0/SDATA3/GPIO42	I/O	I2C0 data / FlashMedia data interface	Hi-Z
84	DDATA0/CTS1/ SDATA0_SDIO1/GPIO1	I/O	Debug / UART1 CTS / FlashMedia data interface	Out / HIGH
85	DDATA1/RTS1/ SDATA2_BS2/GPIO2	I/O	Debug / UART1 RTS / FlashMedia data interface	Out / HIGH

Table 35. 144 QFP Pin Assignments (continued)

144 QFP Pin Number	Name	Type	Description	Pin State After Reset
86	DDATA2/CTS0/GPIO3	I/O	Debug / UART0 CTS	Out / HIGH
87	DDATA3/RTS0/GPIO4	I/O	Debug / UART0 RTS	Out / HIGH
88	SCL1/TXD1/GPIO10	I/O	I2C1 clock line / second UART transmit data output	Out / LOW
89	CORE VDD	–	–	–
90	CORE GND	–	–	–
91	SDA1/RXD1/GPIO44	I/O	I2C1 data line / second UART receive data input	Hi-Z
92	PAD VDD	–	–	–
93	TXD0/GPIO45	I/O	First UART transmit data output	Out / HIGH
94	RXD0/GPIO46	I/O	First UART receive data input	In / LOW
95	PST3/INTMON1/ GPIO47	I/O	Debug / interrupt monitor output 1	Out / HIGH
96	PST2/INTMON2/GPIO48	I/O	Debug / interrupt monitor output 2	Out / HIGH
97	PAD GND	–	–	–
98	PST1/GPIO49	I/O	Debug	Out / HIGH
99	PST0/GPIO50	I/O	Debug	Out / HIGH
100	PSTCLK/GPIO51	I/O	Debug	Out / clock output
101	TDO/DSO	O	JTAG/debug	BDM
102	TDI/DSI	I	JTAG/debug	BDM
103	TCK	I	JTAG	BDM
104	TMS/BKPT	I	JTAG/debug	BDM
105	TRST/DSCLK	I	JTAG/Debug	BDM
106	RSTI	I	Reset	X
107	SCLK2/GPIO22	I/O	Audio interfaces serial clock 2	In / LOW
108	LRCK2/GPIO23	I/O	Audio interfaces EBU out 1	In /LOW
109	LINOUT	A	Linear regulator output	X
110	LININ	A	Linear regulator input	X
111	LINGND	–	Linear regulator ground	X
112	SDATAO2/GPIO34	I/O	Audio interfaces serial data output 2	Out / LOW
113	MCLK1/GPIO11	I/O	Audio master clock output 1	Out / clock output
114	HI-Z	I	JTAG	X
115	TEST2	I	Test	X

Table 35. 144 QFP Pin Assignments (continued)

144 QFP Pin Number	Name	Type	Description	Pin State After Reset
116	TEST1	I	Test	X
117	TEST0	I	Test	X
118	SDWE/GPIO38	I/O	SDRAM write enable	Out / HIGH
119	SDCAS/GPIO39	I/O	SDRAM CAS	Out / HIGH
120	PAD VDD	–	–	–
121	SDRAS/GPIO59	I/O	SDRAM RAS	Out / HIGH
122	SD_CS0/GPIO60	I/O	SDRAM chip select out 0	Out / HIGH
123	SDLIQM/GPO52	O	SDRAM LDQM	Out / HIGH
124	SDUDQM/GPO53	O	SDRAM UDQM	Out / HIGH
125	BCLKE/GPIO63	I/O	SDRAM clock enable output	Out / HIGH
126	BCLK/GPIO40	I/O	SDRAM clock output	Out / HIGH
127	DATA31	I/O	Data	X
128	DATA30	I/O	Data	X
129	PAD GND	–	–	–
130	DATA29	I/O	Data	X
131	DATA28	I/O	Data	X
132	DATA27	I/O	Data	X
133	DATA26	I/O	Data	X
134	DATA25	I/O	Data	X
135	PAD-VDD	–	–	–
136	DATA24	I/O	Data	X
137	DATA23	I/O	Data	X
138	DATA22	I/O	Data	X
139	DATA21	I/O	Data	X
140	DATA20	I/O	Data	X
141	PAD GND	–	–	–
142	DATA19	I/O	Data	X
143	DATA18	I/O	Data	X
144	DATA17	I/O	Data	X

5.2 144 QFP Package

The SCF5250 is available in a 144-pin QFP package. For the 144 QFP package drawings, refer to Figure 15 on page 42, Figure 16 on page 43, and Figure 17 on page 44.

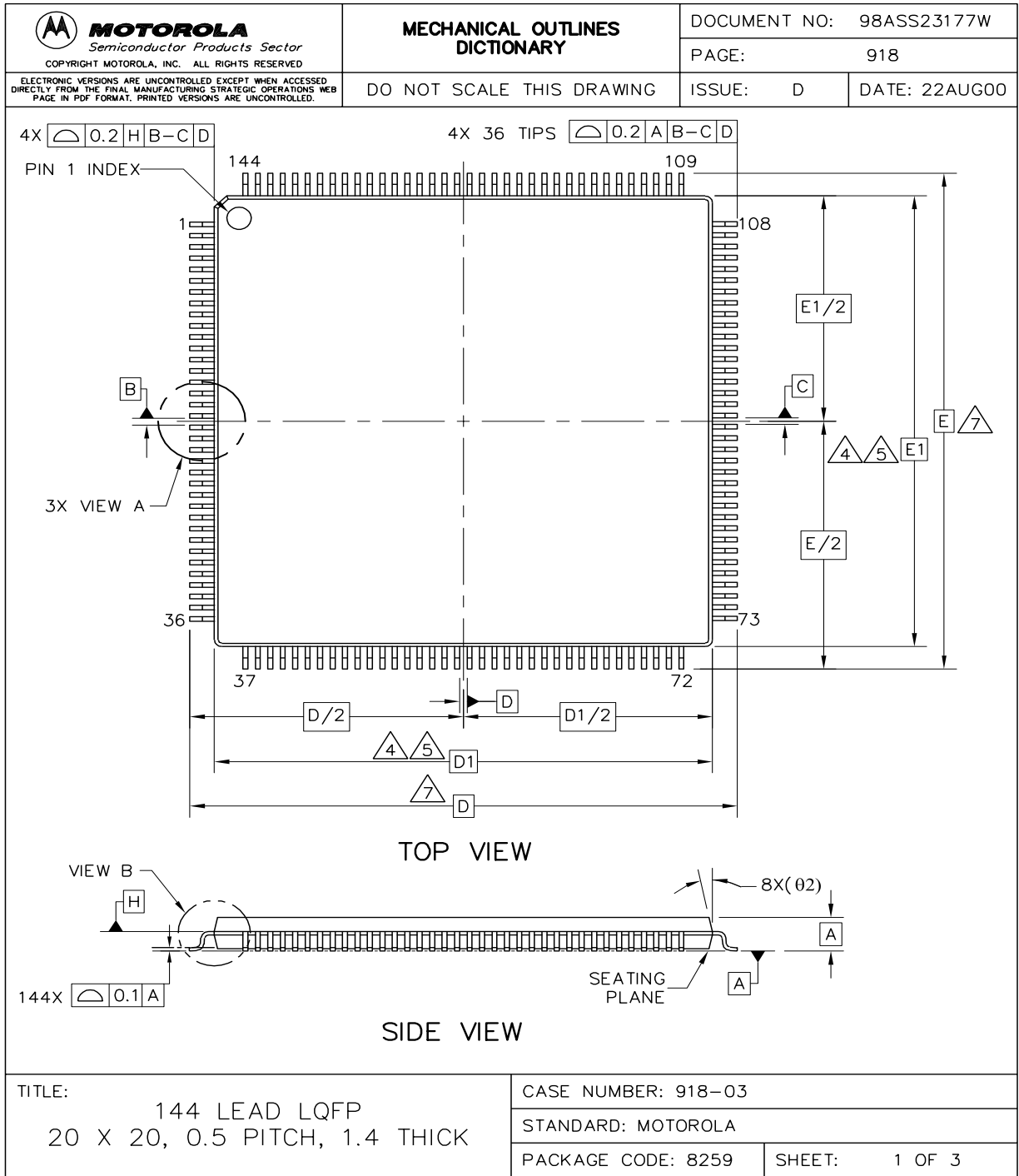

Figure 15. 144 QFP Package (1 of 3)

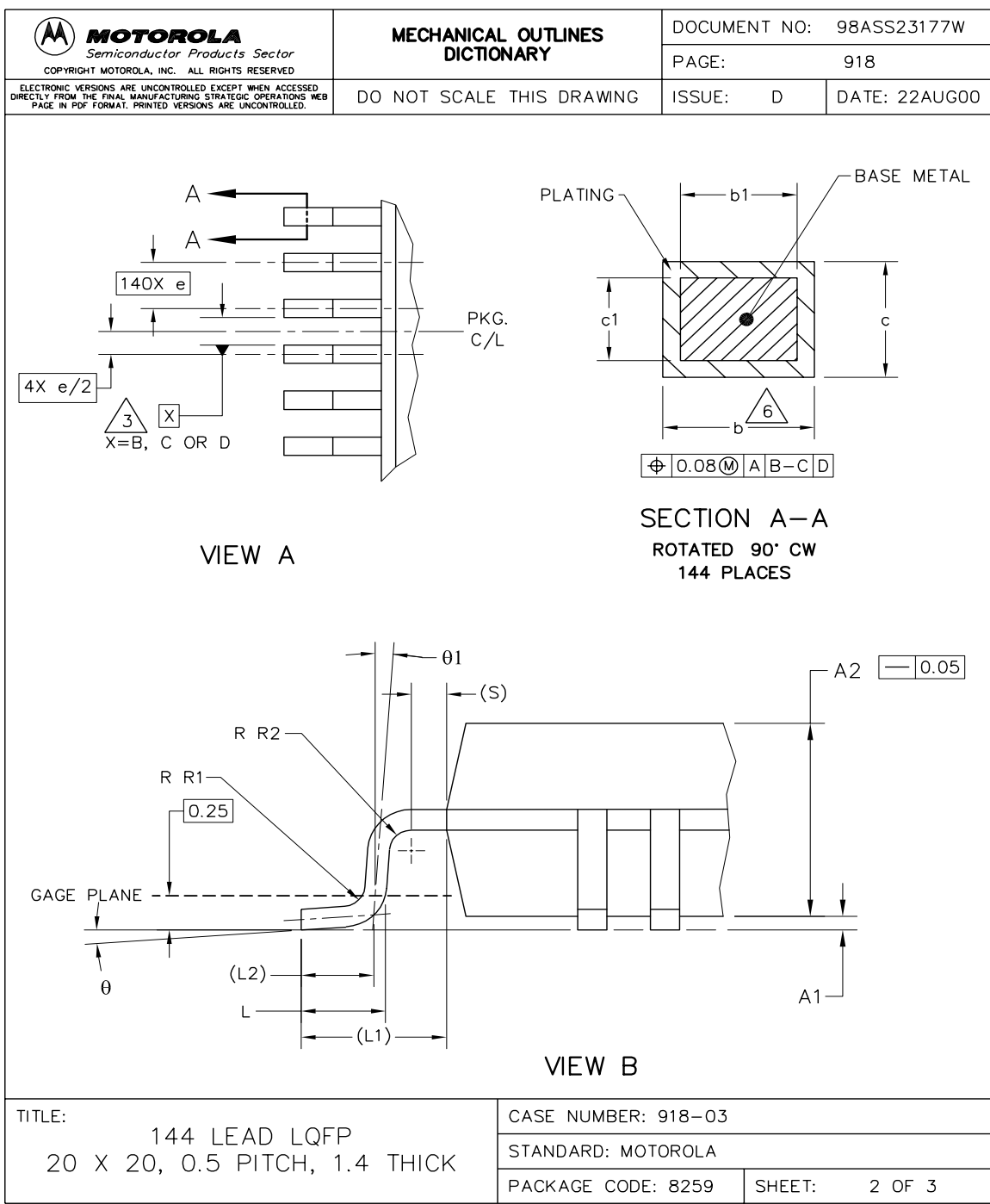

Figure 16. 144 QFP Package (2 of 3)

MOTOROLA Semiconductor Products Sector COPYRIGHT MOTOROLA, INC. ALL RIGHTS RESERVED		MECHANICAL OUTLINES DICTIONARY		DOCUMENT NO: 98ASS23177W				
<small>ELECTRONIC VERSIONS ARE UNCONTROLLED EXCEPT WHEN ACCESSED DIRECTLY FROM THE FINAL MANUFACTURING STRATEGIC OPERATIONS WEB PAGE IN PDF FORMAT. PRINTED VERSIONS ARE UNCONTROLLED.</small>		DO NOT SCALE THIS DRAWING		PAGE: 918				
				ISSUE: D	DATE: 22AUG00			
NOTES: 1. ALL DIMENSIONS ARE IN MILLIMETERS. 2. INTERPRET DIMENSIONS AND TOLERANCES PER ASME Y14.5M-1994. 3. DATUMS B, C AND D TO BE DETERMINED AT DATUM PLANE H. 4. THE TOP PACKAGE BODY SIZE MAY BE SMALLER THAN THE BOTTOM PACKAGE SIZE BY A MAXIMUM OF 0.1 mm. 5. DIMENSIONS D1 AND E1 DO NOT INCLUDE MOLD PROTRUSIONS. THE MAXIMUM ALLOWABLE PROTRUSION IS 0.25 mm PER SIDE. D1 AND E1 ARE MAXIMUM BODY SIZE DIMENSIONS INCLUDING MOLD MISMATCH. 6. DIMENSION b DOES NOT INCLUDE DAM BAR PROTRUSION. PROTRUSIONS SHALL NOT CAUSE THE LEAD WIDTH TO EXCEED 0.35. MINIMUM SPACE BETWEEN PROTRUSION AND AN ADJACENT LEAD SHALL BE 0.07 MM. 7. DIMENSIONS D AND E ARE DETERMINED AT THE SEATING PLANE, DATUM A.								
DIM	MIN	MAX	DIM	MIN	MAX	DIM	MIN	MAX
A	-	-	L1	-	1 REF	-	-	-
A1	0.05	-	L2	-	0.5 REF	-	-	-
A2	1.35	-	R1	0.13	-	0.2	-	-
b	0.17	-	R2	0.13	-	-	-	-
b1	0.17	-	S	-	0.25 REF	-	-	-
c	0.09	-	θ	0°	-	7°	-	-
c1	0.09	-	θ1	0°	-	-	-	-
D	-	22 BSC	θ2	-	12° REF	-	-	-
D1	-	20 BSC	-	-	-	-	-	-
e	-	0.5 BSC	-	-	-	-	-	-
E	-	22 BSC	-	-	-	-	-	-
E1	-	20 BSC	-	-	-	-	-	-
L	0.45	-	-	-	-	-	-	-
TITLE:				CASE NUMBER: 918-03				
144 LEAD LQFP 20 X 20, 0.5 PITCH, 1.4 THICK				STANDARD: MOTOROLA				
				PACKAGE CODE: 8259	SHEET: 3 OF 3			

Figure 17. 144 QFP Package (3 of 3)

5.3 196 MAPBGA Pin Assignments

The SCF5250 can be assembled in a 196-pin MAPBGA package. [Table 36](#) lists the 196 MAPBGA pin assignments.

Table 36. 196 MAPBGA Pin Assignments

MAPBGA Pin	Name	Type	Description	Pin State After Reset
B1	DATA16	I/O	Data	X
D3	A23_GPO54	I/O	SDRAM address / static adr	Out (requires pull up/down for boot-up selection)
P_VDD	PST_VDD		PST_VDD	
C1	A22	O	SDRAM address / static adr	Out
D2	A21	O	SDRAM address / static adr	Out
E3	A20_A24	I/O	SDRAM address / static adr	Out (requires pull up/down for boot-up selection)
D1	A19	O	SDRAM address / static adr	Out
E2	A18	O	SDRAM address / static adr	Out
P_GND	PST_GND		PST_GND	
F3	A17	O	SDRAM address / static adr	Out
E1	A16	O	SDRAM address / static adr	Out
F2	A15	O	SDRAM address / static adr	Out
F1	A14	O	SDRAM address / static adr	Out
G3	A13	O	SDRAM address / static adr	Out
P_VDD	PAD_VDD		PAD_VDD	
G2	A12	O	SDRAM address / static adr	Out
G1	A11	O	SDRAM address / static adr	Out
CORE_VDD	CORE_VDD		CORE_VDD	
C_GND	CORE_VSS		CORE_VSS	Out
H2	A10	O	SDRAM address / static adr	Out
J1	A9	O	SDRAM address / static adr	Out
H3	A8	O	SDRAM address / static adr	Out
K1	A7	O	SDRAM address / static adr	Out

Table 36. 196 MAPBGA Pin Assignments (continued)

MAPBGA Pin	Name	Type	Description	Pin State After Reset
J2	A6	O	SDRAM address / static adr	Out
L1	A5	O	SDRAM address / static adr	Out
P_GND	PAD_GND		PAD_GND	
J3	A4	O	SDRAM address / static adr	Out
K2	A3	O	SDRAM address / static adr	Out
L2	A2	O	SDRAM address / static adr	Out
M1	A1	O	SDRAM address / static adr	Out
K3	CS0	O	Static chip select 0	Out
L3	RWB	O	Bus write enable	Out
J5	OSCPAD_VDD		OSCPAD_VDD	
M2	CRIN		Crystal / external clock input	X
N1	CROUT		Crystal clock output	X
J6	OSCPAD_GND		OSCPAD_GND	
K5	PLLCORE_VDD		PLLCORE_VDD	
K5	PLLCORE_VDD		PLLCORE_VDD	
K5	PLLCORE_VDD		PLLCORE_VDD	
K6	PLLCORE_GND		PLLCORE_GND	
K6	PLLCORE_GND		PLLCORE_GND	
K6	PLLCORE_GND		PLLCORE_GND	
M3	OE	O	Output enable	Out
M4	IDEDIOW_GP32	I/O	IDE DIOW	Out / High
M5	IDEIORDY_GP33	I/O	IDE interface IORDY	Out / Low
N3	IDEDIOR_GP31	I/O	IDE interface DIOR	Out / High
M6	BUFENB2_GP30	I/O	External Buffer 2 enable	Out / High
P2	BUFENB1_GP29	I/O	External Buffer 1 enable	Out / High
N4	TA_GP12	I/O	Transfer acknowledge	In (requires pull-up for normal operation)

Table 36. 196 MAPBGA Pin Assignments (continued)

MAPBGA Pin	Name	Type	Description	Pin State After Reset
N5	WAKEUP_GP21	I/O	Wake-up input	In (requires pull-up for normal operation)
P3	EBUIN2_SCLKOUT_GP13	I/O	Audio interfaces EBUIN2 / FlashMedia Clock	In / Low
P4	EBUIN3_CMDSDIO2_GP14	I/O	Audio interfaces EBUIN3 / FlashMedia Clock	In / Low
P_VDD	PAD_VDD	I/O	PAD_VDD	
N6	EBUIN1_GP36	I/O	Audio interfaces EBUIN1	In / Low
P5	EBUOUT1_GP37	I/O	Audio interfaces EBUOUT1	Out / Low
M7	XTRIM_GP0	I/O	Audio interfaces X-tal trim	Out / clock out
P6	QSPICS3_CS1_GP28	I/O	QSPI Chip select 3	Out / High
N7	RCK_QSPIDIN_QSPIDOUT_GP26	I/O	Subcode RCK interface / QSPI Data In / Data out	Out / Low
P7	QSPICLK_SUBR_GP25	I/O	QSPI clockpin / subcode interface	Out / Low
P8	QSPIDOUT_SFSY_GP27	I/O	QSPI Data Output / subcode interface SFSY	Out / Low
M8	QSPICS1_EBUOUT2_GP16	I/O	QSPI Chip select 1 output / audio interface EBU output 2	Out / Low
N8	QSPICS0_EBUIN4_GP15	I/O	QSPI Chip select 0 output / audio interface EBUIN4	Out / Low
P_GND	PAD_GND	I/O	PAD_GND	
P9	SCLK1_GP20	I/O	Audio interfaces serial clock 1	In / Low
M9	LRCK1_GP19	I/O	Audio interfaces word clock 1	In / Low
N9	SDATAO1_TOUT1_GP18	I/O	Audio interfaces serial data output 1 / Timer output 1	Out / Low
P10	SDATAI1_GP17	I/O	Audio interfaces serial data input 1	In / Low
N10	CFLG_GP5	I/O	CFLG input	In / Low
M10	EF_GP6	I/O	Error flag input	In / Low
P11	QSPICS2_MCLK2_GP24	I/O	QSPI Chip select output 2 / audio master clock output 2	Out / Low
N11	SDATAI3_GP8	I/O	Audio interfaces serial data input 3	In / Low

Table 36. 196 MAPBGA Pin Assignments (continued)

MAPBGA Pin	Name	Type	Description	Pin State After Reset
M11	ADIN0_GPI52	A	AD input 0	In only
P12	ADIN1_GPI53	A	AD input 1	In only
P13	ADIN2_GPI54	A	AD input 2	In only
N12	AD_VDD		AD_VDD	
M13	AD_GND		AD_GND	
M12	ADIN3_GPI55	A	AD input 3	In only
L12	ADIN4_GPI56	A	AD input 4	In only
K12	ADIN5_GPI57	A	AD input 5	In only
N13	ADREF	A	ADC reference input	In
N14	ADOUT_SCLK4_GP58	I/O	AD output / SCLK4 (for GPI function in low power applications)	Out / clock output
L13	LRCK3_GP43	I/O	Audio interface LRCK3	In
M14	SCLK3_GP35	I/O	Audio interface SCLK3	In
J12	SCL_SDATA1BS1_GP41	I/O	I2C clock line / FlashMedia data interface	In / Low
L14	SDA_SDATA3_GP42	I/O	I2C data line / FlashMedia data interface	Hi-Z
J13	DDATA0_CTS2B_SDATA0SDIO1_GP1	I/O	Debug / UART2 CTS / FlashMedia data interface	Out / High
K14	DDATA1_RTS2B_SDATA2BS2_GP2	I/O	Debug / UART2 RTS / FlashMedia data interface	Out / High
H12	DDATA2_CTS1B_GP3	I/O	Debug / UART1 CTS	Out / High
J14	DDATA3_RTS1B_GP4	I/O	Debug / UART1 RTS	Out / High
H13	SCL2_TXD2_GP10	I/O	I2C2 clock line / second UART transmit data output	Out / Low
CORE_VDD	CORE_VDD	I/O	CORE_VDD	
C_GND	CORE_GND	I/O	CORE_GND	
H14	SDA2_RXD2_GP44	I/O	I2C2 data line / second UART2 receive data input	Hi-Z
P_VDD	PAD_VDD	I/O	PAD_VDD	
G14	TXD1_GP45	I/O	UART1 transmit data output	Out / High

Table 36. 196 MAPBGA Pin Assignments (continued)

MAPBGA Pin	Name	Type	Description	Pin State After Reset
G13	RXD1_GP46	I/O	UART1 receive data input	Out / Low
G12	PST3_INTMON1_GP47	I/O	Debug / interrupt monitor output 1	Out / High
F12	PST2_INTMON2_GP48	I/O	Debug / interrupt monitor output 2	Out / High
P_GND	PAD_GND	I/O	PAD_GND	
F14	PST1_GP49	I/O	Debug	Out / High
F13	PST0_GP50	I/O	Debug	Out / High
E14	PSTCLK_GP51	I/O	Debug	Out / clock output
E13	TDO_DSO	O	JTAG / Debug	BDM
D13	TDI_DSI	I	JTAG / Debug	BDM
E12	TCK	I	JTAG	BDM
C13	TMS_BKPT	I	JTAG / Debug	BDM
D12	TRST_DSCLK	I	JTAG / Debug	BDM
D14	RSTI	I	Reset	X
C14	SCLK2_GP22	I/O	Audio interfaces serial clock 2	In / Low
B14	LRCK2_GP23	I/O	Audio interfaces word clock 2	In / Low
C11	LINOUT	A	Linear regulator output	X
C11	LINOUT	A	Linear regulator output	X
B12	LININ	A	Linear regulator input	X
B12	LININ	A	Linear regulator input	X
P_GND	LIN_GND		Linear regulator ground	X
C10	SDATAO2_GP34	I/O	Audio interfaces serial data output 2	Out / Low
A12	MCLK1_GP11	I/O	Audio master clock output 1	Out / clock output
---	VBGT			
B11	HIZ_B	I	JTAG	X
B10	TEST2	I	Test	X
C9	TEST1	I	Test	X
A11	TEST0	I	Test	X

Table 36. 196 MAPBGA Pin Assignments (continued)

MAPBGA Pin	Name	Type	Description	Pin State After Reset
B9	SDWE_GP38	I/O	SDRAM write enable	Out / High
A10	SDCAS_GP39	I/O	SDRA CAS	Out / High
P_VDD	PAD_VDD		PAD_VDD	Out / High
C8	SDRAS_GP59	I/O	SDRAM RAS	Out / High
A9	SDCS0_GP60	I/O	SDRAM chip select out 0	Out / High
B8	SDLQDM_GPO52	O	SDRAM LDQM	Out / High
A8	SDUDQM_GPO53	O	SDRAM UDQM	Out / High
A7	BCLKE_GPO63	O	SDRAM clock enable output	Out / High
A6	BCLK_GP40	I/O	SDRAM clock output	Out / High
B7	DATA31	I/O	Data	X
A5	DATA30	I/O	Data	X
P_GND	PAD_GND	I/O	PAD_GND	
C7	DATA29	I/O	Data	X
B6	DATA28	I/O	Data	X
A4	DATA27	I/O	Data	X
B5	DATA26	I/O	Data	X
C6	DATA25	I/O	Data	X
P_VDD	PAD_VDD	I/O	PAD_VDD	
B4	DATA24	I/O	Data	X
B3	DATA23	I/O	Data	X
C5	DATA22	I/O	Data	X
A2	DATA21	I/O	Data	X
B2	DATA20	I/O	Data	X
P_GND	PAD_GND	I/O	PAD_GND	
C4	DATA19	I/O	Data	X
C3	DATA18	I/O	Data	X
C2	DATA17	I/O	Data	X

Table 36. 196 MAPBGA Pin Assignments (continued)

MAPBGA Pin	Name	Type	Description	Pin State After Reset
A1	BGA1_NC_A1	NC		
A14	BGA1_NC_A14	NC		
P1	BGA1_NC_P1	NC		
P14	BGA1_NC_P14	NC		

5.4 196 MAPBGA Package and Ball Map

The SCF5250 is available in a 196-pin MAPBGA package. For the 196 MAPBGA package drawings, refer to Figure 18 on page 52 and Figure 19 on page 53.

For the 196 MAPBGA ball map, refer to Figure 20 on page 54.

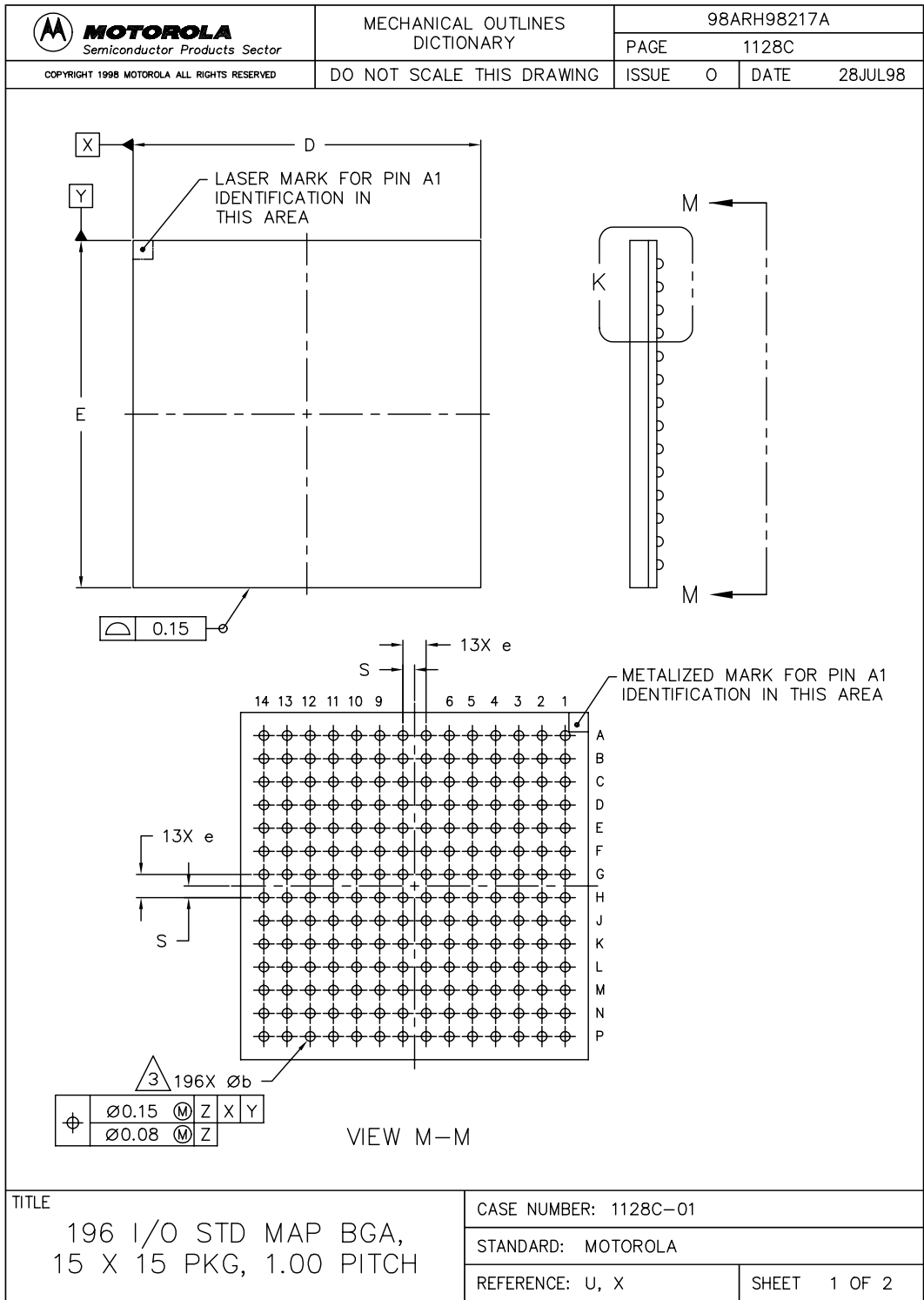

Figure 18. 196 MAPBGA Package (1 of 2)

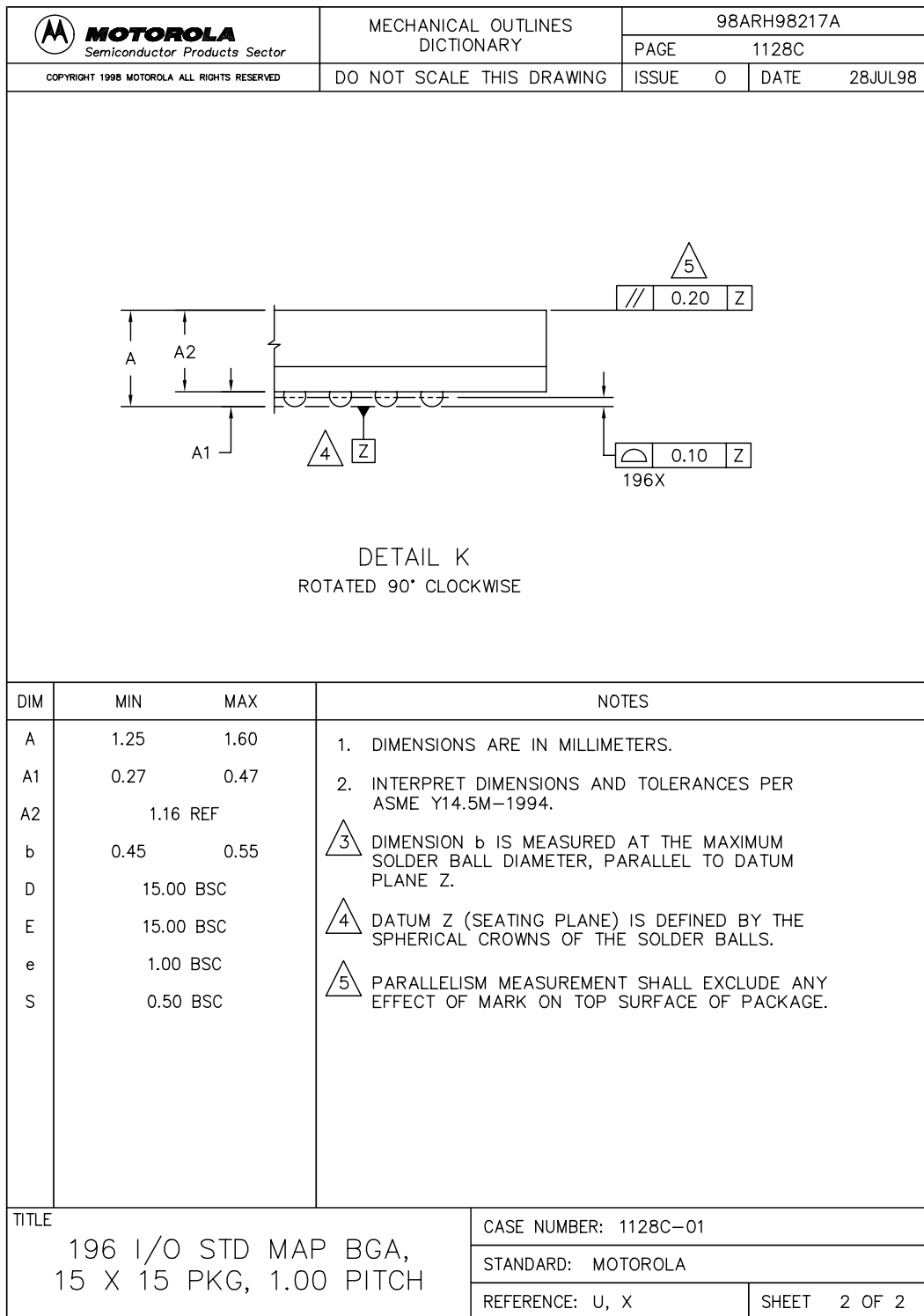

Figure 19. 196 MAPBGA Package (2 of 2)

6 Product Documentation

This section contains this document's revision history and the reference documents that are available to provide more information about the SCF5250 processor.

6.1 Reference Documents

The following list contains the documents that provide a complete description of the SCF5250 and are required to design properly with the part. The documents are available at: <http://www.freescale.com>.

ColdFire Family Programmer's Reference Manual (order number CFPRM)

Version 2/2M ColdFire Core Processor User's Manual (order number ColdFire2UM)

Version 2/2M ColdFire Core Processor User's Manual Addendum (order number ColdFire2UMAD)

SCF5250 User's Manual (order number SCF5250UM)

6.2 Revision History

[Table 37](#) list the revision history for this data sheet.

Table 37. Revision History

Revision	Description
1.3	Added 144 LQFP package drawings. Added 196 MAPBGA package drawings, pin assignments, and ball map.
1.2	Added SCF5250DAG120 and SCF5250EAG120 parts in Table 1 . Content has been reorganized, however there are no other content removal or additions.

How to Reach Us:

Home Page:
www.freescale.com

E-mail:
support@freescale.com

USA/Europe or Locations Not Listed:
Freescale Semiconductor
Technical Information Center, CH370
1300 N. Alma School Road
Chandler, Arizona 85224
+1-800-521-6274 or +1-480-768-2130
support@freescale.com

Europe, Middle East, and Africa:
Freescale Halbleiter Deutschland GmbH
Technical Information Center
Schatzbogen 7
81829 Muenchen, Germany
+44 1296 380 456 (English)
+46 8 52200080 (English)
+49 89 92103 559 (German)
+33 1 69 35 48 48 (French)
support@freescale.com

Japan:
Freescale Semiconductor Japan Ltd.
Headquarters
ARCO Tower 15F
1-8-1, Shimo-Meguro, Meguro-ku,
Tokyo 153-0064, Japan
0120 191014 or +81 3 5437 9125
support.japan@freescale.com

Asia/Pacific:
Freescale Semiconductor Hong Kong Ltd.
Technical Information Center
2 Dai King Street
Tai Po Industrial Estate
Tai Po, N.T., Hong Kong
+800 2666 8080
support.asia@freescale.com

For Literature Requests Only:
Freescale Semiconductor Literature Distribution Center
P.O. Box 5405
Denver, Colorado 80217
1-800-521-6274 or 303-675-2140
Fax: 303-675-2150
LDCForFreescaleSemiconductor@hibbertgroup.com

Information in this document is provided solely to enable system and software implementers to use Freescale Semiconductor products. There are no express or implied copyright licenses granted hereunder to design or fabricate any integrated circuits or integrated circuits based on the information in this document.

Freescale Semiconductor reserves the right to make changes without further notice to any products herein. Freescale Semiconductor makes no warranty, representation or guarantee regarding the suitability of its products for any particular purpose, nor does Freescale Semiconductor assume any liability arising out of the application or use of any product or circuit, and specifically disclaims any and all liability, including without limitation consequential or incidental damages. "Typical" parameters that may be provided in Freescale Semiconductor data sheets and/or specifications can and do vary in different applications and actual performance may vary over time. All operating parameters, including "Typicals", must be validated for each customer application by customer's technical experts. Freescale Semiconductor does not convey any license under its patent rights nor the rights of others. Freescale Semiconductor products are not designed, intended, or authorized for use as components in systems intended for surgical implant into the body, or other applications intended to support or sustain life, or for any other application in which the failure of the Freescale Semiconductor product could create a situation where personal injury or death may occur. Should Buyer purchase or use Freescale Semiconductor products for any such unintended or unauthorized application, Buyer shall indemnify and hold Freescale Semiconductor and its officers, employees, subsidiaries, affiliates, and distributors harmless against all claims, costs, damages, and expenses, and reasonable attorney fees arising out of, directly or indirectly, any claim of personal injury or death associated with such unintended or unauthorized use, even if such claim alleges that Freescale Semiconductor was negligent regarding the design or manufacture of the part.

Freescale™ and the Freescale logo are trademarks of Freescale Semiconductor, Inc. All other product or service names are the property of their respective owners.

© Freescale Semiconductor, Inc. 2006. All rights reserved.

Looking for pricing, stock, or lifecycle information?

Click below to explore more details on WIN SOURCE:

 [View SCF5250CAG120R2 on WIN SOURCE](#)

 [NXP / Nexperia Information](#)

Optimize Your Supply Chain with WIN SOURCE Solutions

-  Global Sourcing Solution
-  Obsolete Management
-  Cost Control Management
-  Shortage Management
-  Alternative Solution
-  Excess Inventory Management