



**THE DATASHEET OF
AM26LV32EMDREP**



LOW-VOLTAGE HIGH-SPEED QUADRUPLE DIFFERENTIAL LINE RECEIVER WITH ± 15 -kV IEC ESD PROTECTION

Check for Samples: [AM26LV32E-EP](#)

FEATURES

- Meets or Exceeds Standard TIA/EIA-422-B and ITU Recommendation V.11
- Operates From a Single 3.3-V Power Supply
- ESD Protection for RS422 Bus Pins
 - ± 15 -kV Human-Body Model (HBM)
 - ± 8 -kV IEC61000-4-2, Contact Discharge
 - ± 15 -kV IEC61000-4-2, Air-Gap Discharge
- Switching Rates up to 32 MHz
- Low Power Dissipation: 27 mW Typ
- Open-Circuit, Short-Circuit, and Terminated Fail-Safe
- ± 7 -V Common-Mode Input Voltage Range With ± 200 -mV Sensitivity
- Accepts 5-V Logic Inputs With 3.3-V Supply (Enable Inputs)
- Input Hysteresis: 35 mV Typ
- Pin-to-Pin Compatible With AM26C32, AM26LS32
- I_{off} Supports Partial-Power-Down Mode Operation

SUPPORTS DEFENSE, AEROSPACE, AND MEDICAL APPLICATIONS

- Controlled Baseline
- One Assembly/Test Site
- One Fabrication Site
- Available in Military ($-55^{\circ}\text{C}/125^{\circ}\text{C}$) Temperature Range ⁽¹⁾
- Extended Product Life Cycle
- Extended Product-Change Notification
- Product Traceability

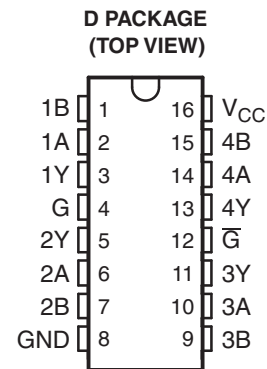

(1) Additional temperature ranges are available – contact factory

DESCRIPTION/ORDERING INFORMATION

The AM26LV32E consists of quadruple differential line receivers with 3-state outputs. These differential receivers have ± 15 -kV ESD (HBM and IEC61000-4-2, Air-Gap Discharge) and ± 8 -kV ESD (IEC61000-4-2, Contact Discharge) protection for RS422 bus pins.

This device is designed to meet TIA/EIA-422-B and ITU recommendation V.11 drivers with reduced supply voltage. The device is optimized for balanced bus transmission at switching rates up to 32 MHz. The 3-state outputs permit connection directly to a bus-organized system.

The AM26LV32E has an internal fail-safe circuitry that prevents the device from putting an unknown voltage signal at the receiver outputs. In the open fail-safe, shorted fail-safe, and terminated fail-safe, a high state is produced at the respective output.

This device is supported for partial-power-down applications using I_{off} . I_{off} circuitry disables the outputs, preventing damaging current backflow through the device when it is powered down.

The AM26LV32EM is characterized for operation from -55°C to 125°C .



Please be aware that an important notice concerning availability, standard warranty, and use in critical applications of Texas Instruments semiconductor products and disclaimers thereto appears at the end of this data sheet.

Table 1. ORDERING INFORMATION

T _A	PACKAGE ⁽¹⁾ (2)		ORDERABLE PART NUMBER	TOP-SIDE MARKING
-55°C to 125°C	SOIC – D	Tape and reel	AM26LV32EMDREP	A26LV32EMP

- (1) Package drawings, thermal data, and symbolization are available at www.ti.com/packaging.
- (2) For the most current package and ordering information, see the Package Option Addendum at the end of this document, or see the TI website at www.ti.com.

**FUNCTION TABLE⁽¹⁾
(each receiver)**

DIFFERENTIAL INPUT	ENABLES		OUTPUT
	G	\bar{G}	
$V_{ID} \geq 0.2 V$	H	X	H
	X	L	H
$-0.2 V < V_{ID} < 0.2 V$	H	X	?
	X	L	?
$V_{ID} \leq -0.2 V$	H	X	L
	X	L	L
Open, shorted, or terminated	H	X	H
	X	L	H
X	L	H	Z

- (1) H = high level, L = low level, X = irrelevant, Z = high impedance (off), ? = indeterminate

LOGIC DIAGRAM (POSITIVE LOGIC)

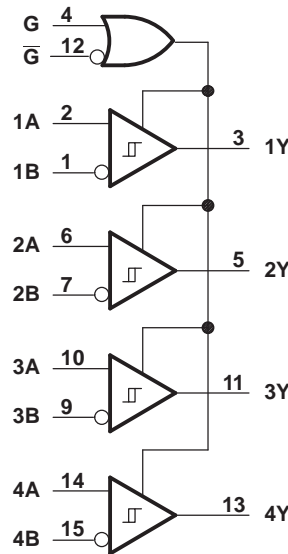

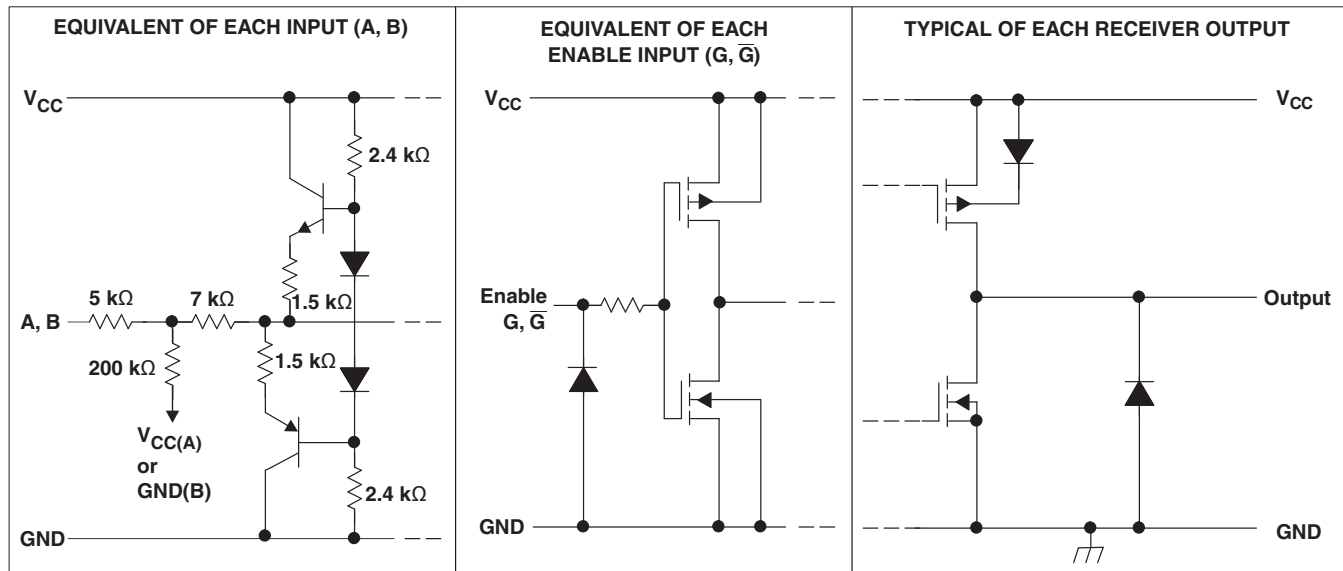
SCHEMATIC

All resistor values are nominal.

ABSOLUTE MAXIMUM RATINGS^{(1) (2)}

over operating free-air temperature range (unless otherwise noted)

		MIN	MAX	UNIT
V_{CC}	Supply voltage range ⁽³⁾	-0.5	6	V
V_I	Input voltage range	A or B inputs		-14 14 V
		Enable Inputs		-0.5 6 V
V_{ID}	Differential input voltage ⁽⁴⁾	-14	14	V
V_O	Output voltage range	-0.5	6	V
I_{IK}	Input clamp current range	$V_I < 0$		-20 mA
I_{OK}	Output clamp current range	$V_O < 0$		-20 mA
I_O	Maximum output current			±20 mA
T_J	Operating virtual junction temperature			150 °C
θ_{JA}	Package thermal impedance ^{(5) (6)}			73 °C/W
T_A	Operating free-air temperature range	-55	125	°C
T_{stg}	Storage temperature range	-65	150	°C

- (1) Stresses beyond those listed under "absolute maximum ratings" may cause permanent damage to the device. These are stress ratings only, and functional operation of the device at these or any other conditions beyond those indicated under "recommended operating conditions" is not implied. Exposure to absolute-maximum-rated conditions for extended periods may affect device reliability.
- (2) This device is designed to meet TIA/EIA-422-B and ITU.
- (3) All voltage values except differential input voltage are with respect to the network GND.
- (4) Differential input voltage is measured at the noninverting input with respect to the corresponding inverting input.
- (5) Maximum power dissipation is a function of $T_{J(max)}$, θ_{JA} , and T_A . The maximum allowable power dissipation at any allowable ambient temperature is $P_D = (T_{J(max)} - T_A)/\theta_{JA}$. Selecting the maximum of 150°C can affect reliability.
- (6) The package thermal impedance is calculated in accordance with JESD 51-7.

RECOMMENDED OPERATING CONDITIONS

		MIN	NOM	MAX	UNIT
V_{CC}	Supply voltage	3	3.3	3.6	V
V_{IH}	Enable high-level input voltage	2		5.5	V
V_{IL}	Enable low-level input voltage	0		0.8	V
V_{IC}	Common-mode input voltage	-7		7	V
V_{ID}	Differential input voltage	-7		7	V
I_{OH}	High-level output current			-5	mA
I_{OL}	Low-level output current			5	mA
T_A	Operating free-air temperature	-55		125	°C

ELECTRICAL CHARACTERISTICS

over recommended ranges of common-mode input, supply voltage, and operating free-air temperature (unless otherwise noted)

PARAMETER	TEST CONDITIONS	MIN	TYP ⁽¹⁾	MAX	UNIT
V_{IT+}	Positive-going input threshold voltage, differential input			0.2	V
V_{IT-}	Negative-going input threshold voltage, differential input	-0.2			V
V_{hys}	Input hysteresis ($V_{IT+} - V_{IT-}$)		35		mV
V_{IK}	Input clamp voltage, G and \bar{G}	$I_I = -18$ mA		-1.5	V
V_{OH}	High-level output voltage	$V_{ID} = 200$ mV, $I_{OH} = -5$ mA	2.4	3.2	V
		$V_{ID} = 200$ mV, $I_{OH} = -100$ μ A	$V_{CC} - 0.1$		
V_{OL}	Low-level output voltage	$V_{ID} = -200$ mV, $I_{OL} = 5$ mA	0.17	0.5	V
		$V_{ID} = -200$ mV, $I_{OL} = 100$ μ A		0.1	
I_{OZ}	High-impedance state output current	$V_O = V_{CC}$ or GND		± 50	μ A
I_{off}	Output current with power off	$V_{CC} = 0$ V, $V_O = 0$ or 5.5 V		± 100	μ A
I_I	Line input current	Other input at 0 V	$V_I = 10$ V	1.5	mA
			$V_I = -10$ V	-2.5	
I_I	Enable input current, G and \bar{G}	$V_I = V_{CC}$ or GND		± 1	μ A
r_i	Input resistance	$V_{IC} = -7$ V to 7 V, Other input at 0 V	4	17	k Ω
I_{CC}	Supply current (total package)	G, $\bar{G} = V_{CC}$ or GND, No load, Line inputs open	8	17	mA
C_{pd}	Power dissipation capacitance ⁽²⁾	One channel		150	pF

(1) All typical values are at $V_{CC} = 3.3$ V, $T_A = 25^\circ$ C.

(2) C_{pd} determines the no-load dynamic current consumption: $I_S = C_{pd} \times V_{CC} \times f + I_{CC}$

SWITCHING CHARACTERISTICS

over recommended operating free-air temperature range (unless otherwise noted)

PARAMETER		TEST CONDITIONS	MIN	TYP ⁽¹⁾	MAX	UNIT
t_{PLH}	Propagation delay time, low- to high-level output	See Figure 1	8	16	26	ns
t_{PHL}	Propagation delay time, high- to low-level output		8	16	26	ns
t_t	Transition time	See Figure 1		5		ns
t_{PZH}	Output-enable time to high level	See Figure 2		17	40	ns
t_{PZL}	Output-enable time to low level	See Figure 3		10	40	ns
t_{PHZ}	Output-disable time from high level	See Figure 2		20	40	ns
t_{PLZ}	Output-disable time from low level	See Figure 3		16	40	ns
$t_{sk(p)}$	Pulse skew	See Figure 1 ⁽²⁾		4	6	ns
$t_{sk(o)}$	Pulse skew	See Figure 1 ⁽³⁾		4	6	ns
$t_{sk(pp)}$	Pulse skew (device to device)	See Figure 1 ⁽⁴⁾		6	9	ns
$f_{(max)}$	Maximum operating frequency	See Figure 1		32		MHz

(1) All typical values are at $V_{CC} = 3.3\text{ V}$, $T_A = 25^\circ\text{C}$.

(2) $t_{sk(p)}$ is $|t_{pLH} - t_{pHL}|$ of each channel of same device.

(3) $t_{sk(o)}$ is the maximum difference in propagation delay times between any two channels of same device switching in the same direction.

(4) $t_{sk(pp)}$ is the maximum difference in propagation delay times between any two channels of any two devices switching in the same direction.

ESD PROTECTION

PARAMETER	TEST CONDITIONS	TYP	UNIT
Receiver input	HBM	±15	kV
	IEC61000-4-2, Air-Gap Discharge	±15	
	IEC61000-4-2, Contact Discharge	±8	

PARAMETER MEASUREMENT INFORMATION

- A. C_L includes probe and jig capacitance.
- B. The input pulse is supplied by a generator having the following characteristics: PRR = 10 MHz, duty cycle = 50%, $t_r = t_f \leq 2\text{ns}$.
- C. To test the active-low enable \overline{G} , ground G and apply an inverted waveform \overline{G} .

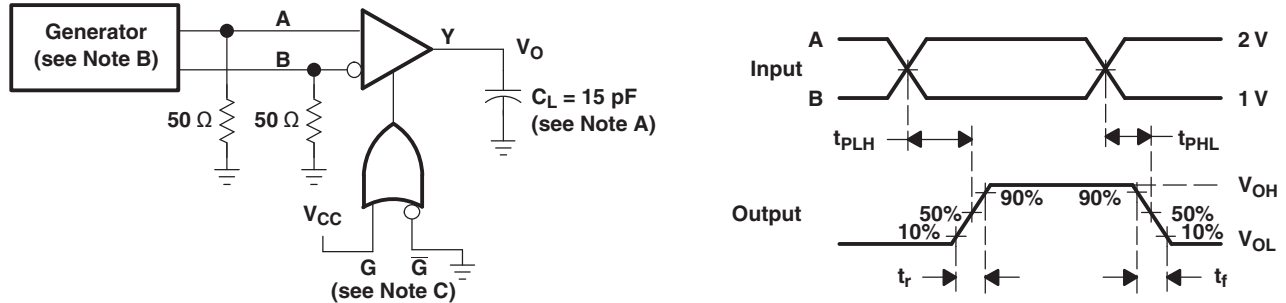

Figure 1. Test Circuit and Voltage Waveforms, t_{PLH} and t_{PHL}

- A. C_L includes probe and jig capacitance.
- B. The input pulse is supplied by a generator having the following characteristics: PRR = 10 MHz, duty cycle = 50%, $t_r = t_f \leq 2\text{ns}$.
- C. To test the active-low enable \overline{G} , ground G and apply an inverted waveform \overline{G} .

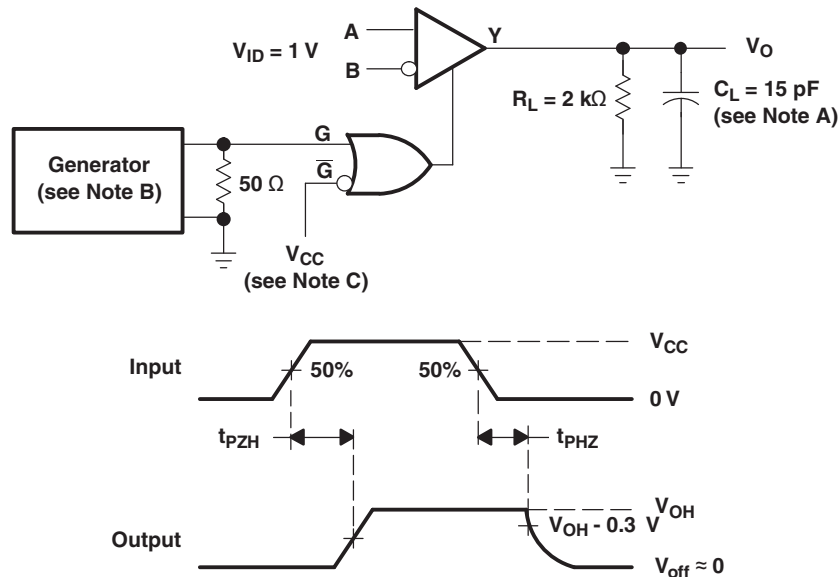

Figure 2. Test Circuit and Voltage Waveforms, t_{PZH} and t_{PHZ}

- A. C_L includes probe and jig capacitance.
- B. The input pulse is supplied by a generator having the following characteristics: PRR = 10 MHz, duty cycle = 50%, $t_r = t_f \leq 2\text{ns}$.
- C. To test the active-low enable \overline{G} , ground G and apply an inverted waveform \overline{G} .

PARAMETER MEASUREMENT INFORMATION (continued)

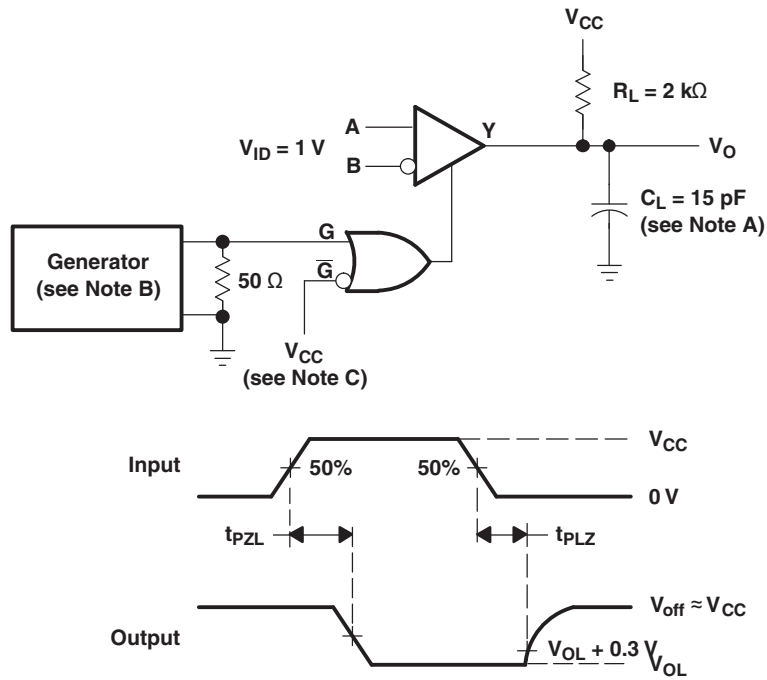

Figure 3. Test Circuit and Voltage Waveforms, t_{PZL} and t_{PLZ}

REVISION HISTORY

Changes from Original (November 2008) to Revision A	Page
• Changed units for V_{IC} and V_{ID} recommended operating conditions from mA to V	4

PACKAGING INFORMATION

Orderable Device	Status (1)	Package Type	Package Drawing	Pins	Package Qty	Eco Plan (2)	Lead finish/ Ball material (6)	MSL Peak Temp (3)	Op Temp (°C)	Device Marking (4/5)	Samples
AM26LV32EMDREP	ACTIVE	SOIC	D	16	2500	RoHS & Green	NIPDAU	Level-1-260C-UNLIM	-55 to 125	A26LV32EMP	Samples
V62/09602-01XE	ACTIVE	SOIC	D	16	2500	RoHS & Green	NIPDAU	Level-1-260C-UNLIM	-55 to 125	A26LV32EMP	Samples

(1) The marketing status values are defined as follows:

ACTIVE: Product device recommended for new designs.

LIFEBUY: TI has announced that the device will be discontinued, and a lifetime-buy period is in effect.

NRND: Not recommended for new designs. Device is in production to support existing customers, but TI does not recommend using this part in a new design.

PREVIEW: Device has been announced but is not in production. Samples may or may not be available.

OBSOLETE: TI has discontinued the production of the device.

(2) **RoHS:** TI defines "RoHS" to mean semiconductor products that are compliant with the current EU RoHS requirements for all 10 RoHS substances, including the requirement that RoHS substance do not exceed 0.1% by weight in homogeneous materials. Where designed to be soldered at high temperatures, "RoHS" products are suitable for use in specified lead-free processes. TI may reference these types of products as "Pb-Free".

RoHS Exempt: TI defines "RoHS Exempt" to mean products that contain lead but are compliant with EU RoHS pursuant to a specific EU RoHS exemption.

Green: TI defines "Green" to mean the content of Chlorine (Cl) and Bromine (Br) based flame retardants meet JS709B low halogen requirements of <=1000ppm threshold. Antimony trioxide based flame retardants must also meet the <=1000ppm threshold requirement.

(3) MSL, Peak Temp. - The Moisture Sensitivity Level rating according to the JEDEC industry standard classifications, and peak solder temperature.

(4) There may be additional marking, which relates to the logo, the lot trace code information, or the environmental category on the device.

(5) Multiple Device Markings will be inside parentheses. Only one Device Marking contained in parentheses and separated by a "~" will appear on a device. If a line is indented then it is a continuation of the previous line and the two combined represent the entire Device Marking for that device.

(6) Lead finish/Ball material - Orderable Devices may have multiple material finish options. Finish options are separated by a vertical ruled line. Lead finish/Ball material values may wrap to two lines if the finish value exceeds the maximum column width.

Important Information and Disclaimer:The information provided on this page represents TI's knowledge and belief as of the date that it is provided. TI bases its knowledge and belief on information provided by third parties, and makes no representation or warranty as to the accuracy of such information. Efforts are underway to better integrate information from third parties. TI has taken and continues to take reasonable steps to provide representative and accurate information but may not have conducted destructive testing or chemical analysis on incoming materials and chemicals. TI and TI suppliers consider certain information to be proprietary, and thus CAS numbers and other limited information may not be available for release.

In no event shall TI's liability arising out of such information exceed the total purchase price of the TI part(s) at issue in this document sold by TI to Customer on an annual basis.

OTHER QUALIFIED VERSIONS OF AM26LV32E-EP :

- Catalog : [AM26LV32E](#)

NOTE: Qualified Version Definitions:

- Catalog - TI's standard catalog product

TAPE AND REEL INFORMATION

QUADRANT ASSIGNMENTS FOR PIN 1 ORIENTATION IN TAPE

*All dimensions are nominal

Device	Package Type	Package Drawing	Pins	SPQ	Reel Diameter (mm)	Reel Width W1 (mm)	A0 (mm)	B0 (mm)	K0 (mm)	P1 (mm)	W (mm)	Pin1 Quadrant
AM26LV32EMDREP	SOIC	D	16	2500	330.0	16.4	6.5	10.3	2.1	8.0	16.0	Q1

TAPE AND REEL BOX DIMENSIONS

*All dimensions are nominal

Device	Package Type	Package Drawing	Pins	SPQ	Length (mm)	Width (mm)	Height (mm)
AM26LV32EMDREP	SOIC	D	16	2500	340.5	336.1	32.0

D (R-PDSO-G16)

PLASTIC SMALL OUTLINE

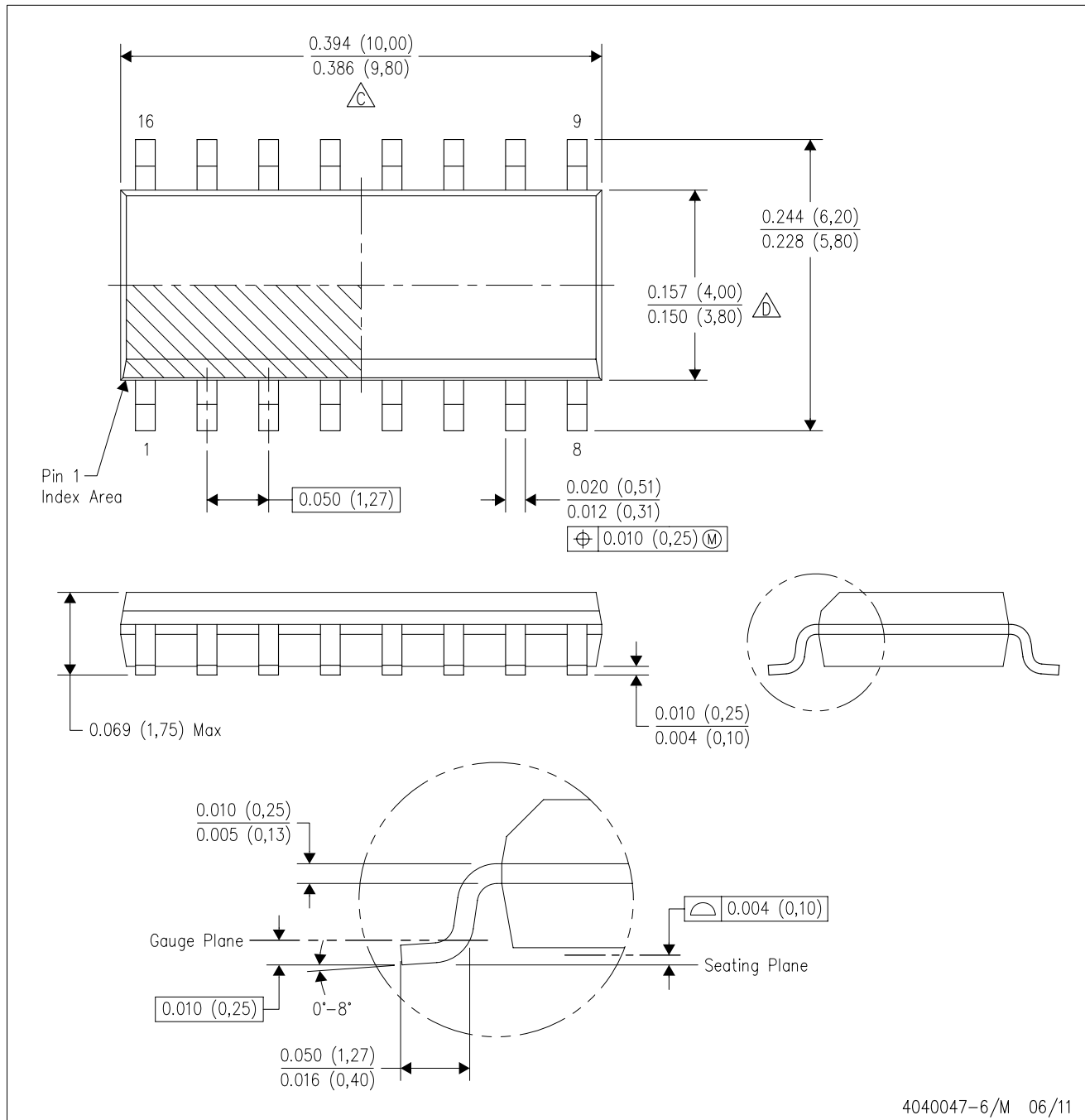

- NOTES:
- A. All linear dimensions are in inches (millimeters).
 - B. This drawing is subject to change without notice.
 - C. Body length does not include mold flash, protrusions, or gate burrs. Mold flash, protrusions, or gate burrs shall not exceed 0.006 (0,15) each side.
 - D. Body width does not include interlead flash. Interlead flash shall not exceed 0.017 (0,43) each side.
 - E. Reference JEDEC MS-012 variation AC.

IMPORTANT NOTICE AND DISCLAIMER

TI PROVIDES TECHNICAL AND RELIABILITY DATA (INCLUDING DATA SHEETS), DESIGN RESOURCES (INCLUDING REFERENCE DESIGNS), APPLICATION OR OTHER DESIGN ADVICE, WEB TOOLS, SAFETY INFORMATION, AND OTHER RESOURCES "AS IS" AND WITH ALL FAULTS, AND DISCLAIMS ALL WARRANTIES, EXPRESS AND IMPLIED, INCLUDING WITHOUT LIMITATION ANY IMPLIED WARRANTIES OF MERCHANTABILITY, FITNESS FOR A PARTICULAR PURPOSE OR NON-INFRINGEMENT OF THIRD PARTY INTELLECTUAL PROPERTY RIGHTS.

These resources are intended for skilled developers designing with TI products. You are solely responsible for (1) selecting the appropriate TI products for your application, (2) designing, validating and testing your application, and (3) ensuring your application meets applicable standards, and any other safety, security, regulatory or other requirements.

These resources are subject to change without notice. TI grants you permission to use these resources only for development of an application that uses the TI products described in the resource. Other reproduction and display of these resources is prohibited. No license is granted to any other TI intellectual property right or to any third party intellectual property right. TI disclaims responsibility for, and you will fully indemnify TI and its representatives against, any claims, damages, costs, losses, and liabilities arising out of your use of these resources.

TI's products are provided subject to [TI's Terms of Sale](#) or other applicable terms available either on [ti.com](https://www.ti.com) or provided in conjunction with such TI products. TI's provision of these resources does not expand or otherwise alter TI's applicable warranties or warranty disclaimers for TI products.

TI objects to and rejects any additional or different terms you may have proposed.

Mailing Address: Texas Instruments, Post Office Box 655303, Dallas, Texas 75265
Copyright © 2024, Texas Instruments Incorporated

Looking for pricing, stock, or lifecycle information?

Click below to explore more details on WIN SOURCE:

 [View AM26LV32EMDREP](#) on WIN SOURCE

 [Texas Instruments](#) Information

Optimize Your Supply Chain with WIN SOURCE Solutions

-  Global Sourcing Solution
-  Obsolete Management
-  Cost Control Management
-  Shortage Management
-  Alternative Solution
-  Excess Inventory Management