



**THE DATASHEET OF
QS4A201QG8**





QUICKSWITCH® PRODUCTS HIGH-PERFORMANCE CMOS TWO-BY-TWO ANALOG CROSS POINT SWITCH

IDTQS4A201

FEATURES:

- Low ON resistance: $r_{DS(ON)} = 5\Omega$
- Fast transition time: $t_{TRAN} = 6ns$
- Wide bandwidth: 1.3GHz (-3dB point)
- Crosstalk: 90dB at 50KHz, -40dB at 5MHz, -30dB at 30MHz
- Off-isolation: -70dB at 50KHz, -40dB at 5MHz, -30dB at 30MHz
- Single 5V supply
- Can be used as multiplexer or demultiplexer
- TTL-compatible control inputs
- Ultra-low quiescent current: $3\mu A$
- Switch turn on time of 6.5ns
- Available in QSOP package

APPLICATIONS:

- High-speed video signal switching/routing
- HDTV-quality video signal routing
- Phase reversal
- Data acquisition
- ATE systems
- Telecomm routing
- Token Ring transceivers
- High-speed networking

DESCRIPTION:

The QS4A201 is a high-performance CMOS two-by-two analog cross point switch. This device provides two sets of five high-speed CMOS switches providing "cross point" connection between inputs and outputs. The low ON resistance of the QS4A201 allows inputs to be connected to outputs with low insertion loss and high bandwidth. TTL-compatible control circuitry with "Break-Before-Make" feature prevents contention.

The QS4A201 with 1.3GHz bandwidth makes it ideal for high-performance video signal switching, audio signal switching, and telecomm routing applications. High performance and low power dissipation makes this device ideal for battery operated and remote instrumentation applications.

The QS4A201 is offered in the QSOP package and has several advantages over conventional packages such as PDIP and SOIC, including:

- Reduced signal delays due to denser component packaging on circuit boards
- Reduced system noise due to less pin inductance

The QS4A201 is characterized for operation at $-40^{\circ}C$ to $+85^{\circ}C$.

FUNCTIONAL BLOCK DIAGRAM

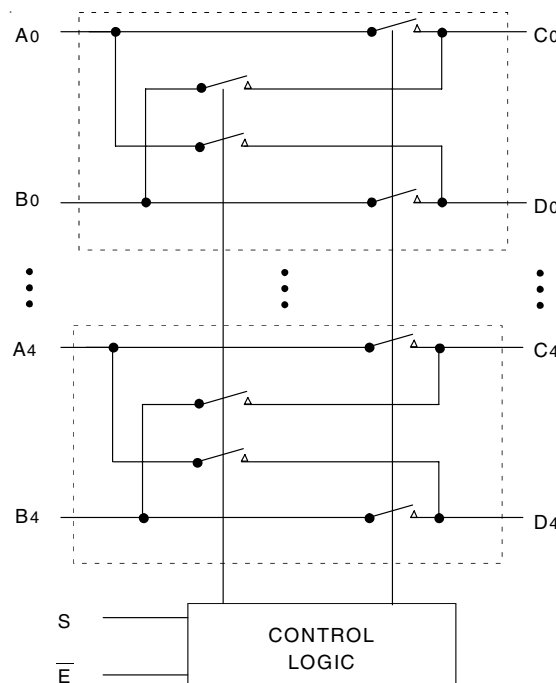

IDT and the IDT logo are registered trademarks of Integrated Device Technology, Inc.

INDUSTRIAL TEMPERATURE RANGE

APRIL 2014

PIN CONFIGURATION

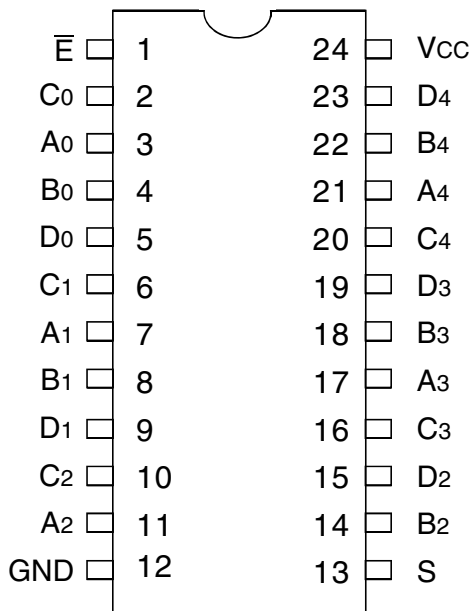

QSOP
TOP VIEW

ABSOLUTE MAXIMUM RATINGS⁽¹⁾

Symbol	Description	Max	Unit
VTERM ⁽²⁾	Supply Voltage to Ground	-0.5 to +7	V
VTERM ⁽³⁾	DC Switch Voltage V _s	-0.5 to +7	V
—	Analog Input Voltage	-0.5 to +7	V
VTERM ⁽³⁾	DC Input Voltage V _{IN}	-0.5 to +7	V
VAC	AC Input Voltage (pulse width ≤20ns)	-3	V
I _{OUT}	DC Output Current	120	mA
P _{MAX}	Maximum Power Dissipation	0.7	W
T _{STG}	Storage Temperature	-65 to +150	°C

NOTES:

- Stresses greater than those listed under ABSOLUTE MAXIMUM RATINGS may cause permanent damage to the device. This is a stress rating only and functional operation of the device at these or any other conditions above those indicated in the operational sections of this specification is not implied. Exposure to absolute maximum rating conditions for extended periods may affect reliability.
- V_{CC} terminals.
- All terminals except V_{CC}.

PIN DESCRIPTION

Pin Names	I/O	Description
A _x , B _x	I/O	Ports A, B
C _x , D _x	I/O	Ports C, D
E-bar	I	Bus Switch Enable
S	I	Bus Exchange

FUNCTION TABLE⁽¹⁾

E-bar	S	A _x	B _x	Function
H	X	Z	Z	Disable
L	L	C _x	D _x	Enable
L	H	D _x	C _x	Exchange

NOTE:

- H = HIGH Voltage Level
L = LOW Voltage Level
X = Don't Care
Z = High-Impedance

DC ELECTRICAL CHARACTERISTICS OVER OPERATING RANGE

Following Conditions Apply Unless Otherwise Specified:

Industrial: TA = -40°C to +85°C, VCC = 5V ± 5%

Symbol	Parameter	Test Conditions	Min.	Typ. ⁽¹⁾	Max.	Unit
Analog Switch						
V _{IN}	Analog Signal Range ⁽²⁾		-0.5	1	V _{CC} - 1	V
r _{DS(ON)}	Drain-source ON resistance ^(2,3)	V _{CC} = Min., V _{IN} = 0V, I _{ON} = 30mA	—	5	7	Ω
		V _{CC} = Min., V _{IN} = 2.4V, I _{ON} = 15mA	—	13	17	
I _{C(OFF)}	Channel Off Leakage Current	A _x , B _x = V _{CC} or 0V; C _x , D _x = 0V or V _{CC} ; \bar{E} = V _{CC}	—	1	—	nA
I _{C(ON)}	Channel On Leakage Current	A _x = B _x = 0V (each channel is turned on sequentially)	—	1	—	nA
Digital Control						
V _{IH}	Input HIGH Voltage	Guaranteed Logic HIGH for Control Pins	2	—	—	V
V _{IL}	Input LOW Voltage	Guaranteed Logic LOW for Control Pins	—	—	0.8	V
Dynamic Characteristics						
t _{TRANS}	Exchange Switching Time S to C _x , D _x	R _L = 1KΩ, C _L = 100pF (See Transition Time)	0.5	—	6.6	ns
t _{ON(\bar{E})}}	Enable Turn-On Time \bar{E} to C _x , D _x	R _L = 1KΩ, C _L = 100pF (See Switching Time)	0.5	—	6.5	ns
t _{OFF(\bar{E})}}	Enable Turn-Off Time \bar{E} to C _x , D _x	R _L = 1KΩ, C _L = 100pF (See Switching Time)	0.5	—	6	ns
t _{PD}	Group Delay ^(2,4a)	R _L = 1KΩ, C _L = 100pF	—	—	250	ps
f _{dB}	-3dB Bandwidth	V _{IN} = 0 to 1V, 1V _{p-p} , R _L = 75Ω	—	1.3	—	GHz
	Off-isolation	V _{IN} = 0 to 1V, 1V _{p-p} , R _L = 75Ω, f = 5.5MHz	—	-40	—	dB
X _{TALK}	Crosstalk	V _{IN} = 0 to 1V, 1V _{p-p} , R _L = 75Ω, f = 5.5MHz	—	-40	—	dB
C _(OFF)	Switch Off Capacitance	\bar{E} = V _{CC} , V _{IN} = V _{OUT} = 0V	—	5	—	pF
C _(ON)	Switch On Capacitance	\bar{E} = 0V, V _{IN} = V _{OUT} = 0V	—	10	—	pF
Q _{CI}	Charge Injection		—	1.5	—	pC

NOTES:

1. Typical values are at V_{CC} = 5.0V, T_A = 25°C.
2. Max value is guaranteed but not production tested.
3. Measured by voltage drop between A and C pins or B and D pins at indicated current through the switch. ON resistance is determined by the lower of the voltages on the two (A, C, or B, D) pins.
4. The bus switch contributes no group delay other than the RC delay of the ON resistance of the switch and load capacitance. Group delay of the bus switch, when used in a system, is determined by the driving circuit on the driving side of the switch and its interaction with the load on the driven side.

POWER SUPPLY CHARACTERISTICS

Symbol	Parameter	Test Conditions	Max.	Unit
I _{CC}	Supply Current	V _{CC} = Max., V _{IN} = GND or V _{CC}	3	μA

TYPICAL CHARACTERISTICS

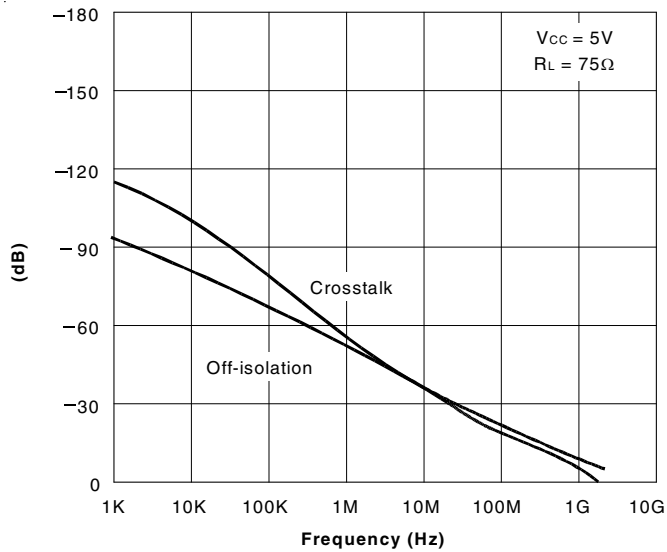

Off-isolation and Crosstalk vs. Frequency

NOTES:

1. Crosstalk = $20 \log |V_o/V_s|$
2. Off-isolation = $20 \log |V_o/V_s|$

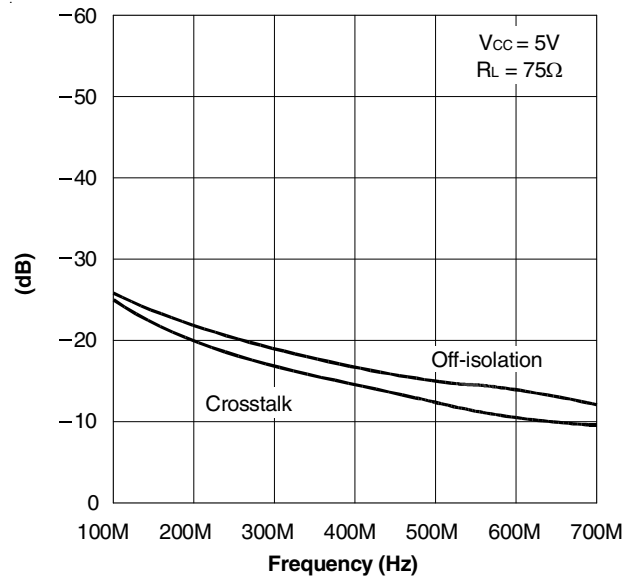

Off-isolation and Crosstalk vs. Frequency

NOTES:

1. Crosstalk = $20 \log |V_o/V_s|$
2. Off-isolation = $20 \log |V_o/V_s|$

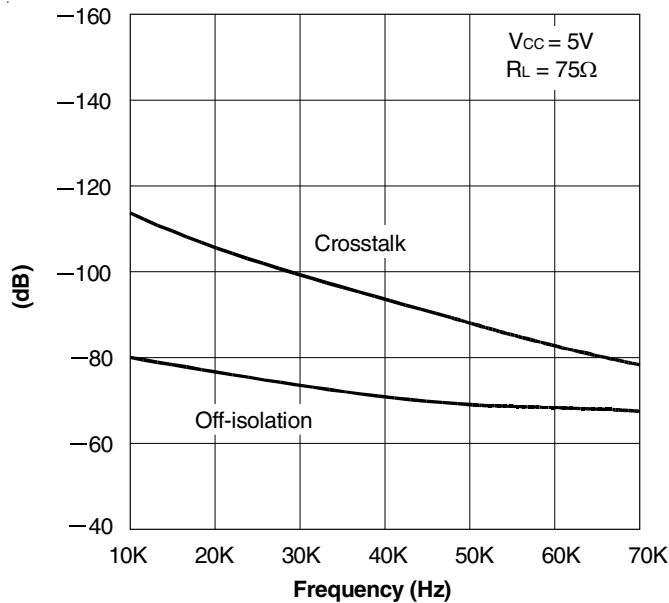

Off-isolation and Crosstalk vs. Frequency

NOTES:

1. Crosstalk = $20 \log |V_o/V_s|$
2. Off-isolation = $20 \log |V_o/V_s|$

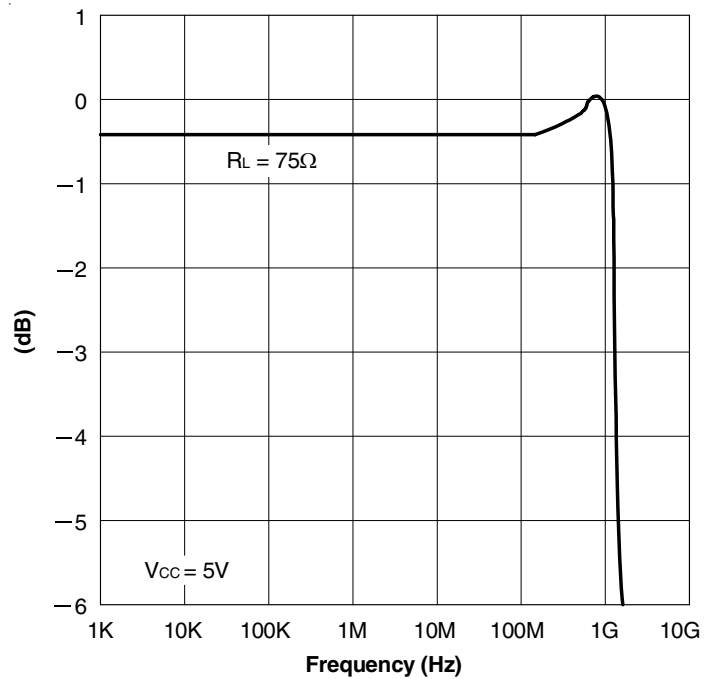

Insertion Loss vs. Frequency

NOTE:

1. Insertion Loss = $20 \log |V_o/V_s|$

TYPICAL CHARACTERISTICS (CONTINUED)

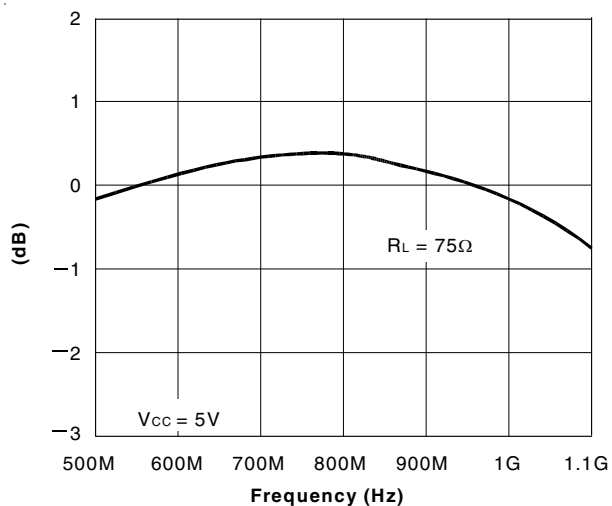

Insertion Loss vs. Frequency

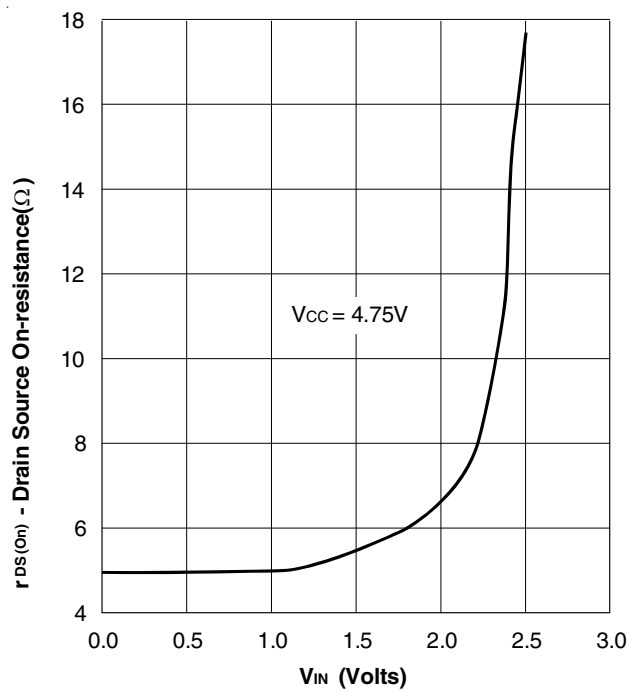

On-Resistance vs. VIN

NOTE:
 1. Insertion Loss = 20 log |Vo/Vs|

RON LINK

TEST CIRCUITS

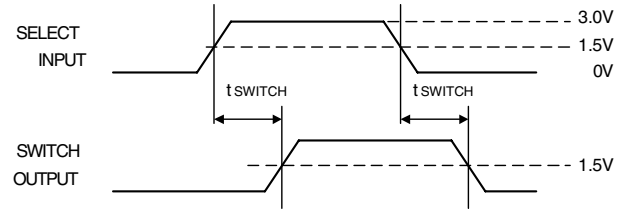
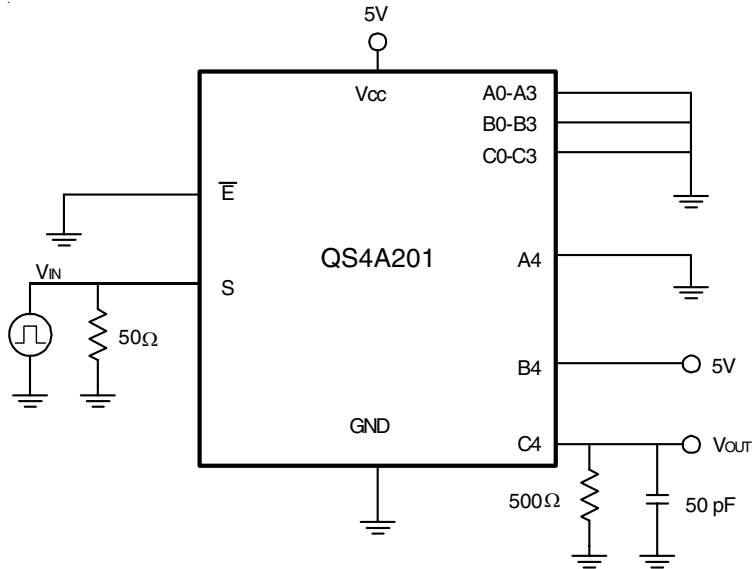

Transition Time

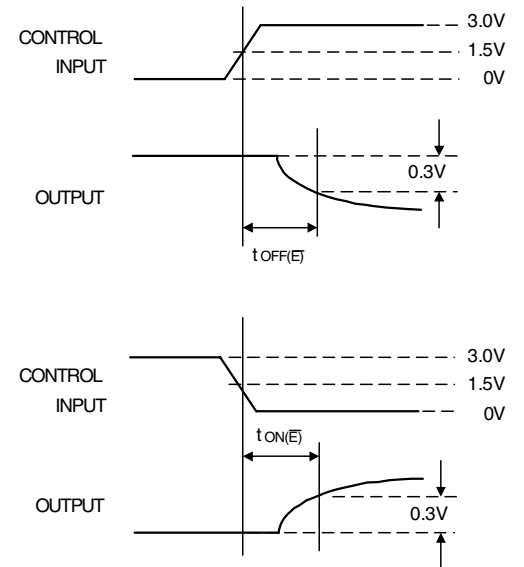
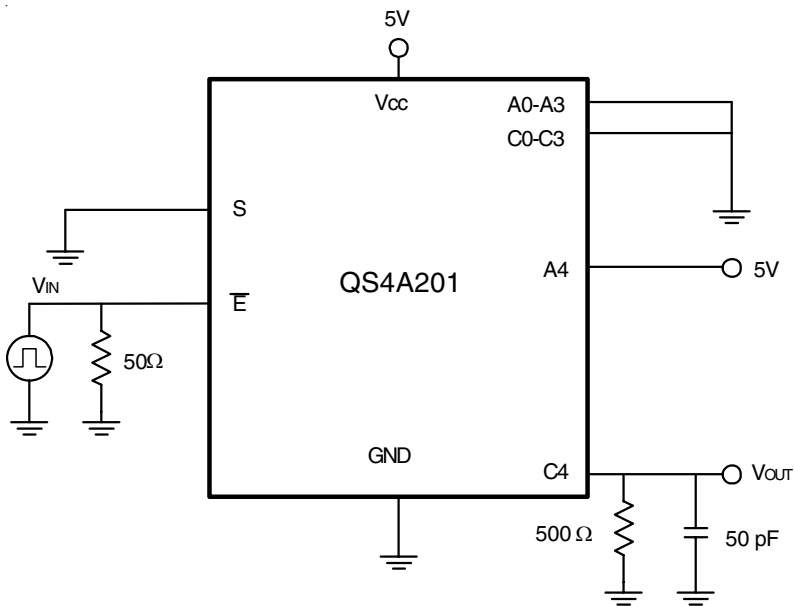

Switching Time

TEST CIRCUITS (CONTINUED)

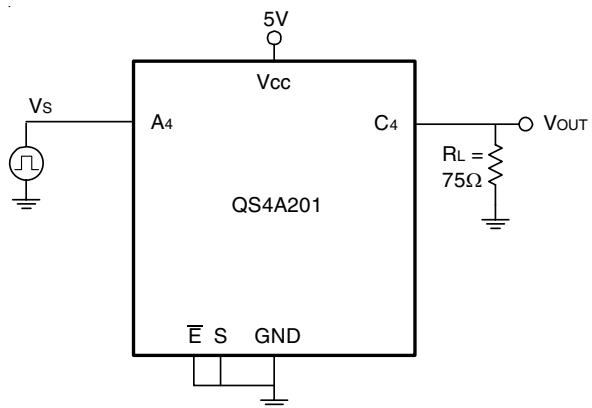

Insertion Loss

NOTES:

1. Insertion Loss = $20 \log |V_o/V_s|$
2. All unused pins are grounded.

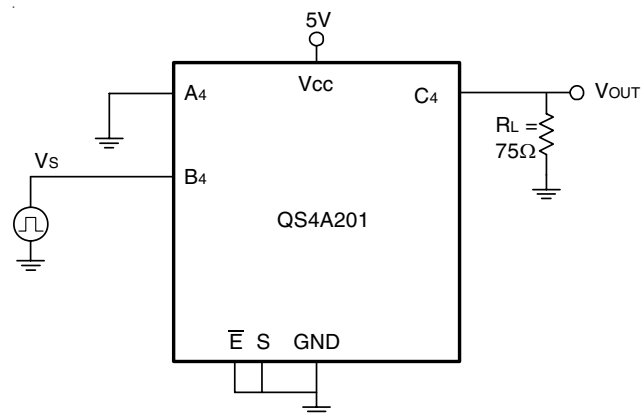

Crosstalk

NOTES:

1. Crosstalk = $20 \log |V_o/V_s|$
2. All unused pins are grounded.

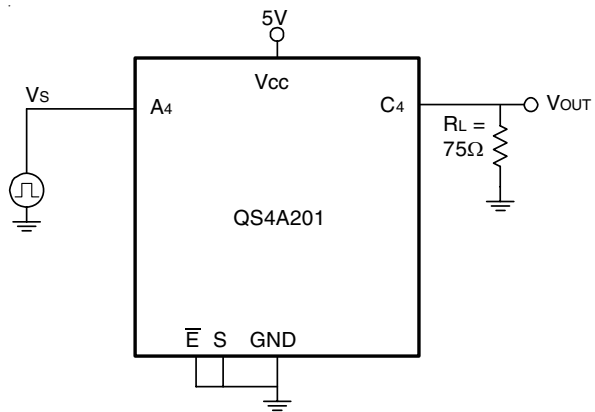

Off-Isolation

NOTES:

1. Off-isolation = $20 \log |V_o/V_s|$
2. All unused pins are grounded.

ORDERING INFORMATION

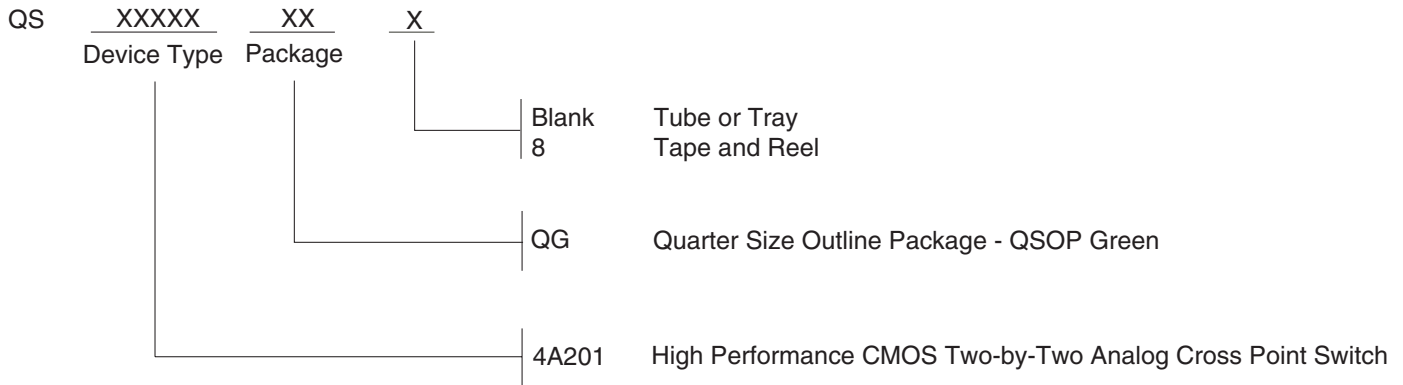

DATASHEET DOCUMENT HISTORY

04/13/2014 Pg. 8 Updated the Ordering Information by removing non green package version, the "IDT" notation and Adding Tape and Reel information.



CORPORATE HEADQUARTERS
6024 Silver Creek Valley Road
San Jose, CA 95138

for SALES:
800-345-7015 or 408-284-8200
fax: 408-284-2775
www.idt.com

for Tech Support:
logichelp@idt.com

Looking for pricing, stock, or lifecycle information?

Click below to explore more details on WIN SOURCE:

- ⊖ [View QS4A201QG8 on WIN SOURCE](#)
- ⊖ [IDT, Integrated Device Technology Inc Information](#)

Optimize Your Supply Chain with WIN SOURCE Solutions

- ✓ Global Sourcing Solution
- ✓ Obsolete Management
- ✓ Cost Control Management
- ✓ Shortage Management
- ✓ Alternative Solution
- ✓ Excess Inventory Management