



**THE DATASHEET OF  
IXGH30N60BD1**



# HiPerFAST™ IGBT with Diode

**IXGH 30N60BD1**  
**IXGT 30N60BD1**

$V_{CES} = 600\text{ V}$   
 $I_{C25} = 60\text{ A}$   
 $V_{CE(sat)} = 1.8\text{ V}$   
 $t_{fi(typ)} = 100\text{ ns}$

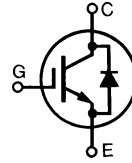

| Symbol  | Test Conditions  | Maximum Ratings                  |                  |
|---|--|----------------------------------|------------------|
| $V_{CES}$   | $T_J = 25^\circ\text{C}$ to $150^\circ\text{C}$  | 600                              | V                |
| $V_{CGR}$   | $T_J = 25^\circ\text{C}$ to $150^\circ\text{C}$ ; $R_{GE} = 1\text{ M}\Omega$  | 600                              | V                |
| $V_{GES}$   | Continuous   | $\pm 20$                         | V                |
| $V_{GEM}$   | Transient  | $\pm 30$                         | V                |
| $I_{C25}$   | $T_C = 25^\circ\text{C}$   | 60                               | A                |
| $I_{C90}$   | $T_C = 90^\circ\text{C}$   | 30                               | A                |
| $I_{CM}$  | $T_C = 25^\circ\text{C}$ , 1 ms  | 120                              | A                |
| <b>SSOA</b><br><b>(RBSOA)</b>   | $V_{GE} = 15\text{ V}$ , $T_{VJ} = 125^\circ\text{C}$ , $R_G = 10\ \Omega$<br>Clamped inductive load, $L = 100\ \mu\text{H}$ | $I_{CM} = 60$<br>@ $0.8 V_{CES}$ | A                |
| $P_C$   | $T_C = 25^\circ\text{C}$   | 200                              | W                |
| $T_J$   |  | -55 ... +150                     | $^\circ\text{C}$ |
| $T_{JM}$  |  | 150                              | $^\circ\text{C}$ |
| $T_{stg}$   |  | -55 ... +150                     | $^\circ\text{C}$ |
| Maximum Lead and Tab temperature for soldering<br>1.6 mm (0.062 in.) from case for 10 s |  | 300                              | $^\circ\text{C}$ |
| $M_d$   | Mounting torque, TO-247 AD   | 1.13/10                          | Nm/lb.in.        |
| <b>Weight</b>   | TO-247 AD  | 6                                | g                |
|   | TO-268   | 4                                | g                |

**TO-268**  
**(IXGT)**

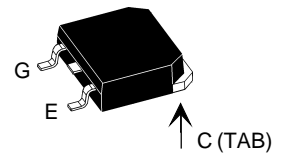

**TO-247 AD**  
**(IXGH)**

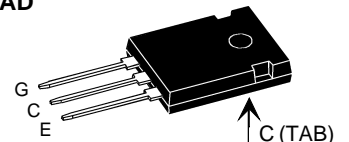

G = Gate, C = Collector,  
E = Emitter, TAB = Collector

### Features

- International standard package
- Moderate frequency IGBT and antiparallel FRED in one package
- High current handling capability
- Newest generation HDMOS™ process
- MOS Gate turn-on - drive simplicity

### Applications

- AC motor speed control
- DC servo and robot drives
- DC choppers
- Uninterruptible power supplies (UPS)
- Switch-mode and resonant-mode power supplies

### Advantages

- Space savings (two devices in one package)
- High power density
- Optimized  $V_{CE(sat)}$  and switching speeds for medium frequency application

| Symbol        | Test Conditions                                       | Characteristic Values<br>( $T_J = 25^\circ\text{C}$ , unless otherwise specified) |      |                     |
|---------------|---|---|------|---------------------|
|               |   | min.  | typ. | max.                |
| $BV_{CES}$    | $I_C = 250\ \mu\text{A}$ , $V_{GE} = 0\text{ V}$      | 600   |      | V                   |
| $V_{GE(th)}$  | $I_C = 250\ \mu\text{A}$ , $V_{CE} = V_{GE}$          | 2.5   |      | 5.0 V               |
| $I_{CES}$     | $V_{CE} = 0.8 \cdot V_{CES}$<br>$V_{GE} = 0\text{ V}$ | $T_J = 25^\circ\text{C}$  |      | 200 $\mu\text{A}$   |
|               |   | $T_J = 150^\circ\text{C}$   |      | 3 mA                |
| $I_{GES}$     | $V_{CE} = 0\text{ V}$ , $V_{GE} = \pm 20\text{ V}$    |   |      | $\pm 100\text{ nA}$ |
| $V_{CE(sat)}$ | $I_C = I_{C90}$ , $V_{GE} = 15\text{ V}$              |   |      | 1.8 V               |

| Symbol       | Test Conditions   | Characteristic Values<br>( $T_J = 25^\circ\text{C}$ , unless otherwise specified) |      |          |    |
|--------------|---|---|------|----------|----|
|              |   | min.  | typ. | max.     |    |
| $g_{fs}$     | $I_C = I_{C90}$ ; $V_{CE} = 10\text{ V}$ ,<br>Pulse test, $t \leq 300\ \mu\text{s}$ , duty cycle $\leq 2\%$   |   | 25   | S        |    |
| $C_{ies}$    | $V_{CE} = 25\text{ V}$ , $V_{GE} = 0\text{ V}$ , $f = 1\text{ MHz}$   |   | 2700 | pF       |    |
| $C_{oes}$    |   |   | 240  | pF       |    |
| $C_{res}$    |   |   | 50   | pF       |    |
| $Q_g$        | $I_C = I_{C90}$ ; $V_{GE} = 15\text{ V}$ , $V_{CE} = 0.5 V_{CES}$   |   | 110  | nC       |    |
| $Q_{ge}$     |   |   | 22   | nC       |    |
| $Q_{gc}$     |   |   | 40   | nC       |    |
| $t_{d(on)}$  | <b>Inductive load, <math>T_J = 25^\circ\text{C}</math></b><br>$I_C = I_{C90}$ , $V_{GE} = 15\text{ V}$ , $L = 100\ \mu\text{H}$ ,<br>$V_{CE} = 0.8 V_{CES}$ , $R_G = R_{off} = 4.7\ \Omega$<br>Remarks: Switching times may increase for $V_{CE}$ (Clamp) $> 0.8 \cdot V_{CES}$ ,<br>higher $T_J$ or increased $R_G$  |   | 25   | ns       |    |
| $t_{ri}$     |   |   | 30   | ns       |    |
| $t_{d(off)}$ |   |   | 130  | 220      | ns |
| $t_{fi}$     |   |   | 100  | 190      | ns |
| $E_{off}$    |   |   | 1.0  | 2.0      | mJ |
| $t_{d(on)}$  | <b>Inductive load, <math>T_J = 150^\circ\text{C}</math></b><br>$I_C = I_{C90}$ , $V_{GE} = 15\text{ V}$ , $L = 100\ \mu\text{H}$ ,<br>$V_{CE} = 0.8 V_{CES}$ , $R_G = R_{off} = 4.7\ \Omega$<br>Remarks: Switching times may increase for $V_{CE}$ (Clamp) $> 0.8 \cdot V_{CES}$ ,<br>higher $T_J$ or increased $R_G$ |   | 25   | ns       |    |
| $t_{ri}$     |   |   | 35   | ns       |    |
| $E_{on}$     |   |   | 1.0  | mJ       |    |
| $t_{d(off)}$ |   |   | 200  | ns       |    |
| $t_{fi}$     |   |   | 230  | ns       |    |
| $E_{off}$    |   | 2.5   | mJ   |          |    |
| $R_{thJC}$   |   |   |      | 0.62 K/W |    |
| $R_{thCK}$   | (TO-247 AD)   |   | 0.25 | K/W      |    |

### Reverse Diode (FRED)

| Symbol     | Test Conditions   | Characteristic Values<br>( $T_J = 25^\circ\text{C}$ , unless otherwise specified) |      |                |
|------------|---|---|------|----------------|
|            |   | min.  | typ. | max.           |
| $V_F$      | $I_F = I_{C90}$ , $V_{GE} = 0\text{ V}$ , Pulse test<br>$t \leq 300\ \mu\text{s}$ , duty cycle $d \leq 2\%$   | $T_J = 150^\circ\text{C}$   |      | 1.6 V<br>2.5 V |
| $I_{RM}$   | $I_F = I_{C90}$ , $V_{GE} = 0\text{ V}$ , $-di_F/dt = 100\text{ A}/\mu\text{s}$<br>$V_R = 100\text{ V}$<br>$I_F = 1\text{ A}$ ; $-di/dt = 100\text{ A}/\mu\text{s}$ ; $V_R = 30\text{ V}$ | $T_J = 100^\circ\text{C}$   |      | 6 A            |
| $t_{rr}$   |   |   |      | 100 ns         |
|            |   |   |      | 25 ns          |
| $R_{thJC}$ |   |   |      | 0.9 K/W        |

### Min. Recommended Footprint

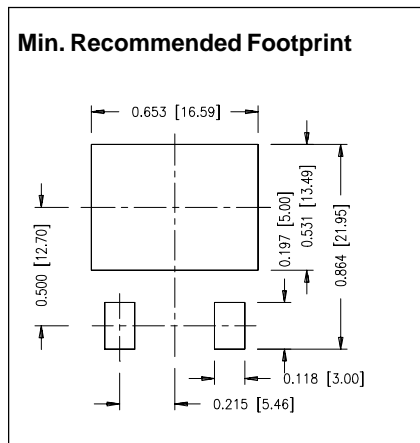

### TO-247 AD (IXGH) Outline

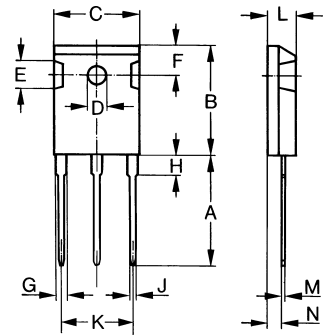

| Dim. | Millimeter |       | Inches |       |
|------|------------|-------|--------|-------|
|      | Min.       | Max.  | Min.   | Max.  |
| A    | 19.81      | 20.32 | 0.780  | 0.800 |
| B    | 20.80      | 21.46 | 0.819  | 0.845 |
| C    | 15.75      | 16.26 | 0.610  | 0.640 |
| D    | 3.55       | 3.65  | 0.140  | 0.144 |
| E    | 4.32       | 5.49  | 0.170  | 0.216 |
| F    | 5.4        | 6.2   | 0.212  | 0.244 |
| G    | 1.65       | 2.13  | 0.065  | 0.084 |
| H    | -          | 4.5   | -      | 0.177 |
| J    | 1.0        | 1.4   | 0.040  | 0.055 |
| K    | 10.8       | 11.0  | 0.426  | 0.433 |
| L    | 4.7        | 5.3   | 0.185  | 0.209 |
| M    | 0.4        | 0.8   | 0.016  | 0.031 |
| N    | 1.5        | 2.49  | 0.087  | 0.102 |

### TO-268AA (D<sup>3</sup> PAK)

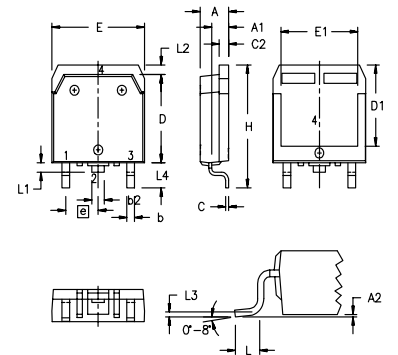

| Dim.           | Millimeter |       | Inches   |      |
|----------------|------------|-------|----------|------|
|                | Min.       | Max.  | Min.     | Max. |
| A              | 4.9        | 5.1   | .193     | .201 |
| A <sub>1</sub> | 2.7        | 2.9   | .106     | .114 |
| A <sub>2</sub> | .02        | .25   | .001     | .010 |
| b              | 1.15       | 1.45  | .045     | .057 |
| b <sub>2</sub> | 1.9        | 2.1   | .75      | .83  |
| C              | .4         | .65   | .016     | .026 |
| D              | 13.80      | 14.00 | .543     | .551 |
| E              | 15.85      | 16.05 | .624     | .632 |
| E <sub>1</sub> | 13.3       | 13.6  | .524     | .535 |
| e              | 5.45 BSC   |       | .215 BSC |      |
| H              | 18.70      | 19.10 | .736     | .752 |
| L              | 2.40       | 2.70  | .094     | .106 |
| L <sub>1</sub> | 1.20       | 1.40  | .047     | .055 |
| L <sub>2</sub> | 1.00       | 1.15  | .039     | .045 |
| L <sub>3</sub> | 0.25 BSC   |       | .010 BSC |      |
| L <sub>4</sub> | 3.80       | 4.10  | .150     | .161 |

Fig. 1. Saturation Voltage Characteristics

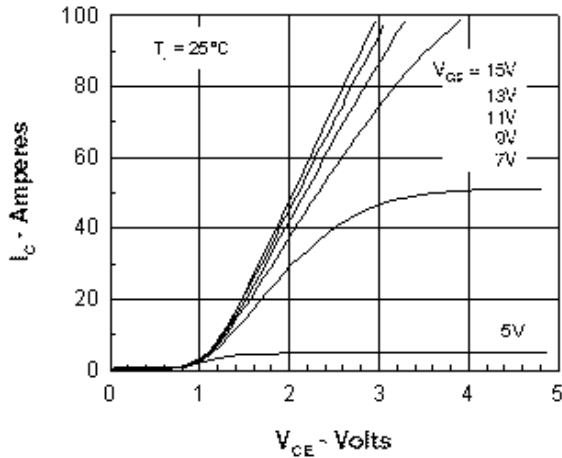

Fig. 3. Saturation Voltage Characteristics

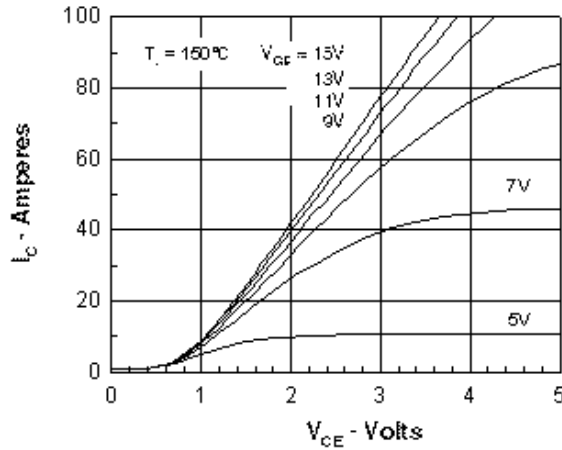

Fig. 5. Admittance Curves

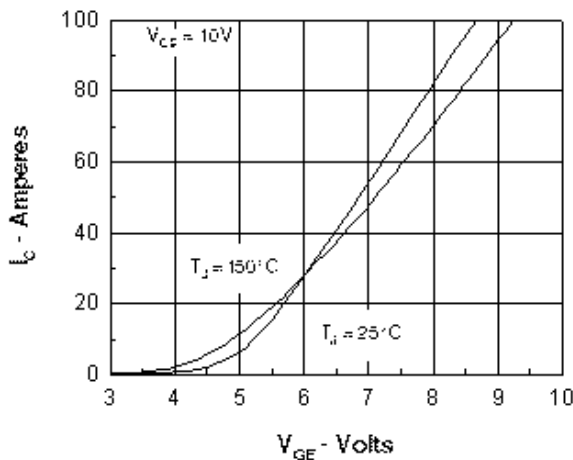

Fig. 2. Extended Output Characteristics

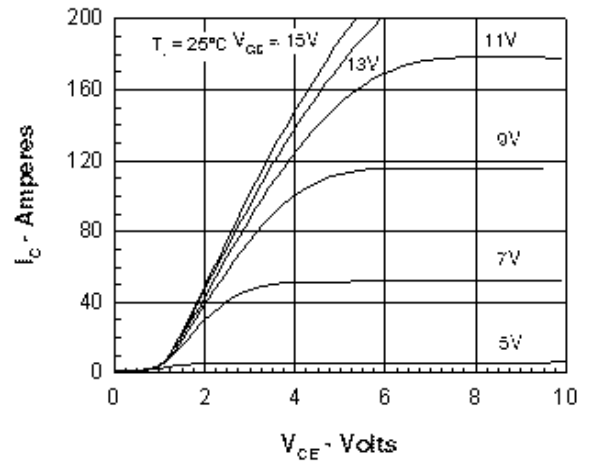
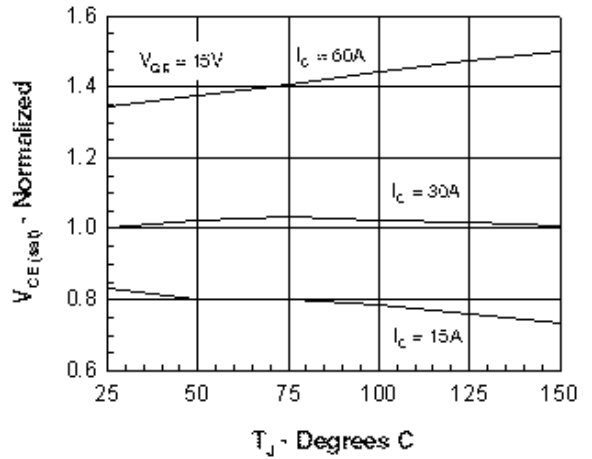
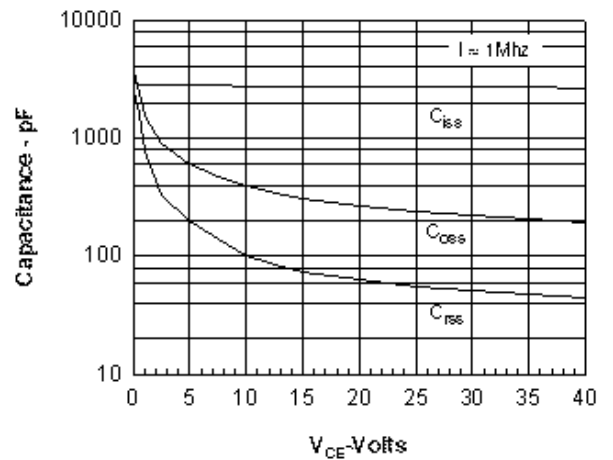

 Fig. 4. Temperature Dependence of  $V_{CE(sat)}$ 

 Fig. 6. Temperature Dependence of  $BV_{DSS}$  &  $V_{GE(th)}$ 

Fig. 7. Dependence of  $E_{OFF}$  and  $E_{ON}$  on  $I_C$ .

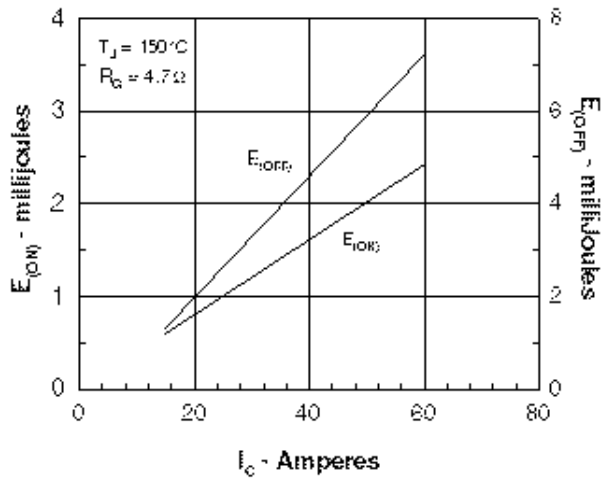

Fig. 8. Dependence of  $E_{OFF}$  on  $R_G$ .

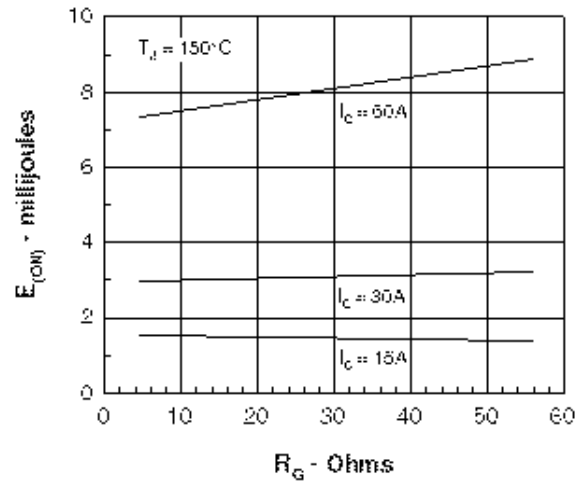

Fig. 9. Gate Charge

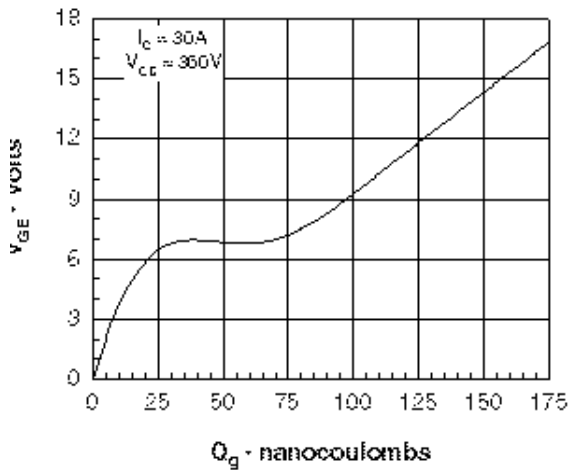

Fig. 10. Turn-off Safe Operating Area

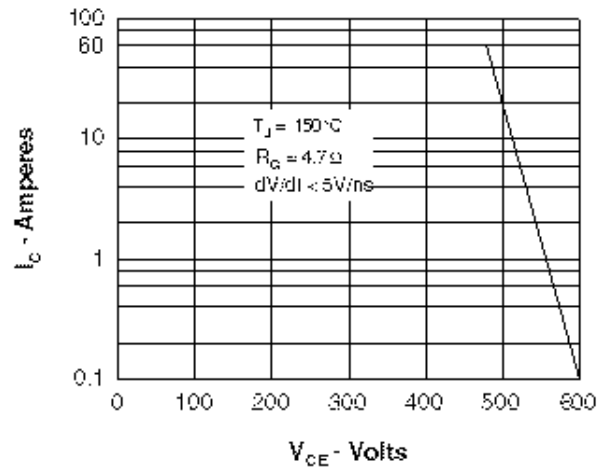
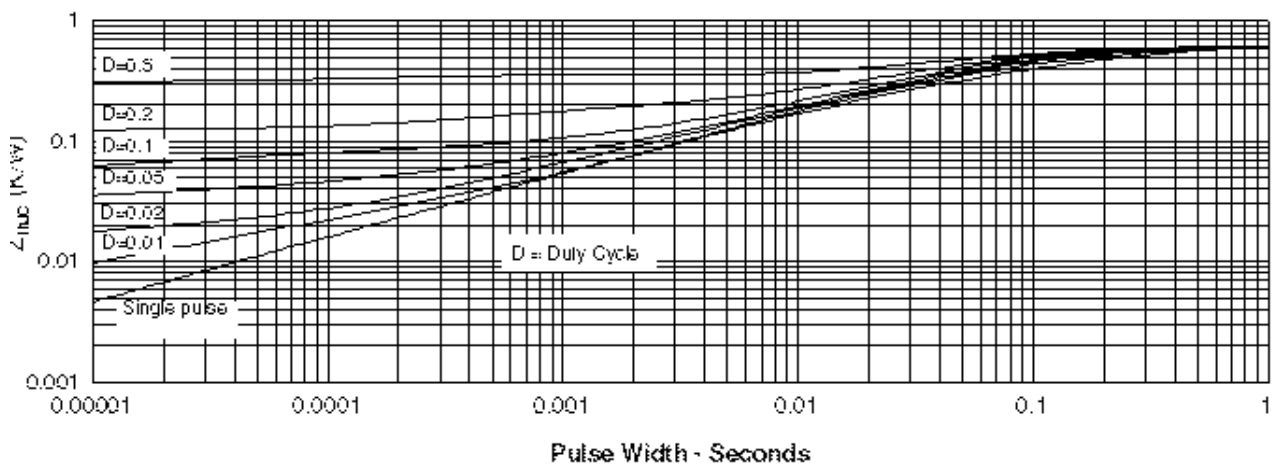

Fig. 11. IGBT Transient Thermal Resistance



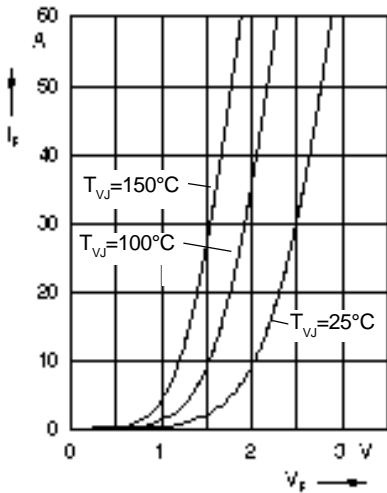

Fig. 12 Forward current  $I_F$  versus  $V_F$

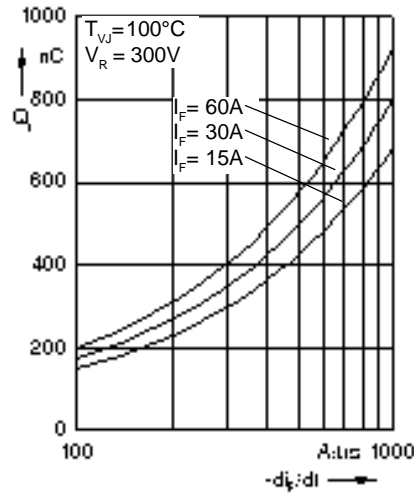

Fig. 13 Reverse recovery charge  $Q_r$  versus  $-di_F/dt$

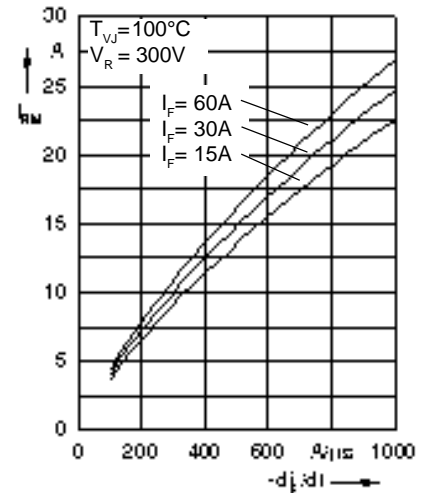

Fig. 14 Peak reverse current  $I_{RM}$  versus  $-di_F/dt$

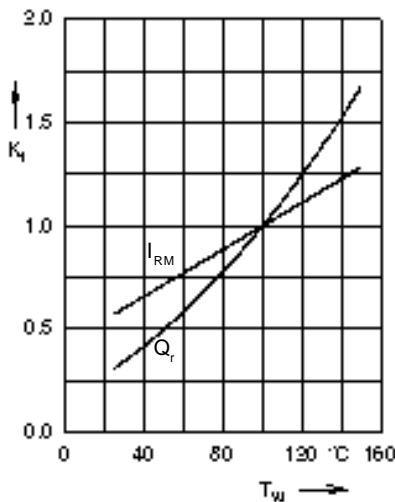

Fig. 15 Dynamic parameters  $Q_r$ ,  $I_{RM}$  versus  $T_{VJ}$

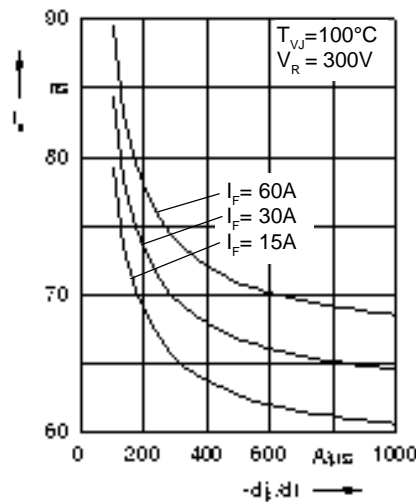

Fig. 16 Recovery time  $t_{tr}$  versus  $-di_F/dt$

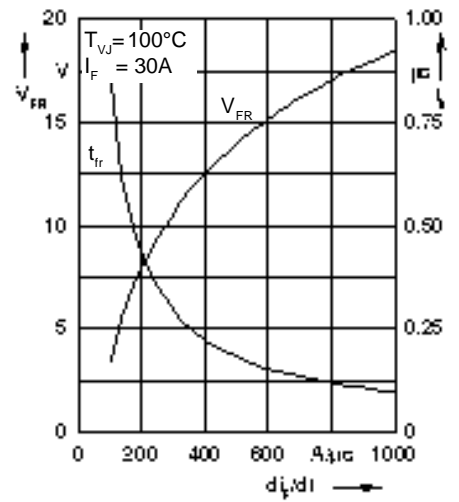

Fig. 17 Peak forward voltage  $V_{FR}$  and  $t_{tr}$  versus  $di_F/dt$

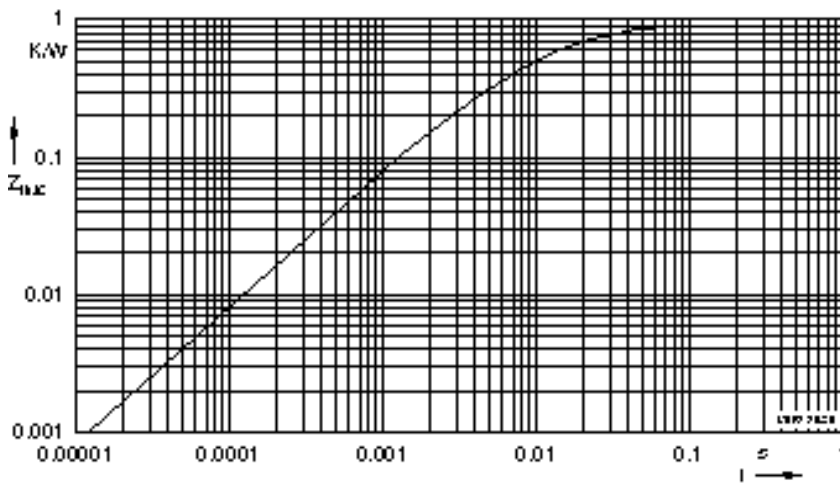

Fig. 18 Transient thermal resistance junction to case

Constants for  $Z_{thJC}$  calculation:

| i | $R_{thi}$ (K/W) | $t_i$ (s) |
|---|-----------------|-----------|
| 1 | 0.502           | 0.0052    |
| 2 | 0.193           | 0.0003    |
| 3 | 0.205           | 0.0162    |

## Looking for pricing, stock, or lifecycle information?

Click below to explore more details on WIN SOURCE:

 [View IXGH30N60BD1 on WIN SOURCE](#)

 [IXYS Information](#)

## Optimize Your Supply Chain with WIN SOURCE Solutions

-  Global Sourcing Solution
-  Obsolete Management
-  Cost Control Management
-  Shortage Management
-  Alternative Solution
-  Excess Inventory Management