



**THE DATASHEET OF
NCS5000SNT1G**



NCS5000

Integrated RF Schottky Detector

The NCS5000 is an integrated Schottky detector intended for use as a level detector in RF measurement/power control applications such as those found in GSM handsets. The detector converts the peak RF voltage applied to a DC level. The circuit consists of an RF Schottky detector, a reference Schottky diode, as well as biasing and control circuitry. There is an enable input that allows the part to be placed in a low power state when not in use.

The detector is designed for operation up to 2.0 GHz and can operate with input power levels up to +25 dBm. There is a fixed offset of 10 mV (nominal) between the Reference Detector and the RF Detector under no applied RF. The two detectors are monolithically integrated so that they closely track overtemperature, voltage and process.

The NCS5000 is housed in a very small TSOP-6 package ideal for portable applications. The TSOP-6 package is a lower profile, footprint compatible package to the SOT23-6.

Features

- Wide Operating Frequency Range to 2.0 GHz
- 2.7 V – 5.5 V Operating Voltage
- Very Low Operating Current of 300 μ A
- Enable Control to Place the Part in a Low Current Standby Mode
- Typical Standby Current of < 1.0 μ A
- -40°C to 85°C Operating Temperature Range
- Very Small TSOP-6 Package
- Pb-Free Package is Available

Typical Applications

- Cellular Handsets (GSM and DCS1800/PCS1900)
- Wireless Data Modems
- Transmitter Power Measurement and Control
- Test Equipment

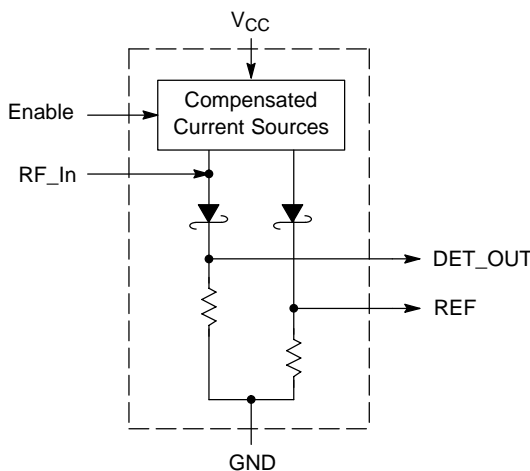

This circuit has 28 active transistors

Figure 1.



ON Semiconductor®

<http://onsemi.com>



TSOP-6
SN SUFFIX
CASE 318G

PIN CONNECTIONS AND MARKING DIAGRAM

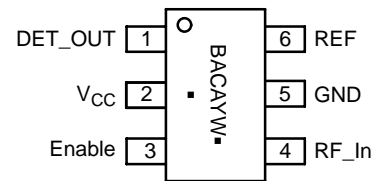

(Top View)

BAC = Specific Device Code
A = Assembly Location
Y = Year
W = Work Week
▪ = Pb-Free Package

(Note: Microdot may be in either location)

ORDERING INFORMATION

Device	Package	Shipping†
NCS5000SNT1	TSOP-6	3000/Tape & Reel
NCS5000SNT1G	TSOP-6 (Pb-Free)	3000/Tape & Reel

†For information on tape and reel specifications, including part orientation and tape sizes, please refer to our Tape and Reel Packaging Specifications Brochure, BRD8011/D.

NCS5000

PIN DESCRIPTION

Pin	Name	Description
1	DET_OUT	This is the RF Detector Output. This signal is proportional to the peak RF voltage applied at the RF_In pin.
2	V _{CC}	Input power supply.
3	Enable	Control signal to turn on and off the device. If this signal is not used, this pin should be connected directly to V _{CC} . A logic high on this input turns on the device.
4	RF_In	This is the input to the RF detector. The signal must be AC-coupled into this input with a good quality RF capacitor.
5	GND	Ground.
6	REF	This is the reference detector output. Nominal this signal is 10 mV higher than DET_OUT when no RF signal is applied at RF_In.

MAXIMUM RATINGS (T_A = 25°C, unless otherwise noted.)

Rating	Symbol	Value	Unit
Maximum Input Power on RF Pin	P _{MAX}	28	dBm
Maximum Power Supply	V _{CCMAX}	6.0	V
ESD Rating for RF_In (HBM) All Other Pins are 2.5 kV (HBM)	–	500	V
Storage Temperature Range	T _{stg}	–40 to +125	°C
Maximum Junction Temperature	T _J	+150	°C
Maximum Input Voltage on Pins	V _{IMAX}	V _{CC} + 0.3 V	–
Minimum Input Voltage on Pins	V _{IMIN}	–0.3 V	–

Stresses exceeding Maximum Ratings may damage the device. Maximum Ratings are stress ratings only. Functional operation above the Recommended Operating Conditions is not implied. Extended exposure to stresses above the Recommended Operating Conditions may affect device reliability.

RECOMMENDED OPERATING CONDITIONS

Characteristic	Symbol	Min	Typ	Max	Unit
RF Input (50 Ω Equivalent)	RF _{in}	–	–	25	dBm
Supply Voltage	V _{CC}	2.7	–	5.5	V
Operating Temperature Range	T _A	–40	–	85	°C

NCS5000

ELECTRICAL CHARACTERISTICS ($V_{CC} = 2.8\text{ V}$, for typical values; Min and Max values at $T_A = 25^\circ\text{C}$)

Characteristic	Symbol	Pin	Min	Typ	Max	Unit
RF Operating Frequency	–	4	100	–	2000	MHz
Operating Current Consumption ($V_{enable} = 2.4\text{ V}$, No RF Applied)	$I_{CC(op)}$	2	–	–	500	μA
Standby Current Consumption ($V_{enable} = 0.4\text{ V}$, No RF Applied)	$I_{CC(stby)}$	2	–	1	10	μA
Power Supply Ripple Rejection ($V_{CC} = 3.6\text{ V}$, $V_{ripple} = 0.5\text{ V}_{PP}$, No RF)	R_R	2	–	56 41	–	dB –
Detector Output (No RF Applied)	DET_OUT	1	40	45	50	mV
Reference Output (No RF Applied)	REF	6	50	55	60	mV
Reference – Detector Output Differential Voltage (No RF Applied)	REF– DET_OUT	1,6	5	10	15	mV
Detector Output $F_{in} = 1.0\text{ GHz}$, $RF_{in} = -5.0\text{ dBm}$ ($50\ \Omega$) $F_{in} = 1.0\text{ GHz}$, $RF_{in} = 5.0\text{ dBm}$ ($50\ \Omega$) $F_{in} = 1.0\text{ GHz}$, $RF_{in} = 15\text{ dBm}$ ($50\ \Omega$)	–	–	–	100 335 1285	–	mV
Enable Logic High	V_{ih}	3	2.4	–	–	V
Enable Logic Low	V_{il}	3	0	–	0.4	V
Enable Input Current, $V_{CC} = 2.7\text{ V}$, $V_{enable} = 2.4\text{ V}$	I_{in}	3	0	–	30	μA

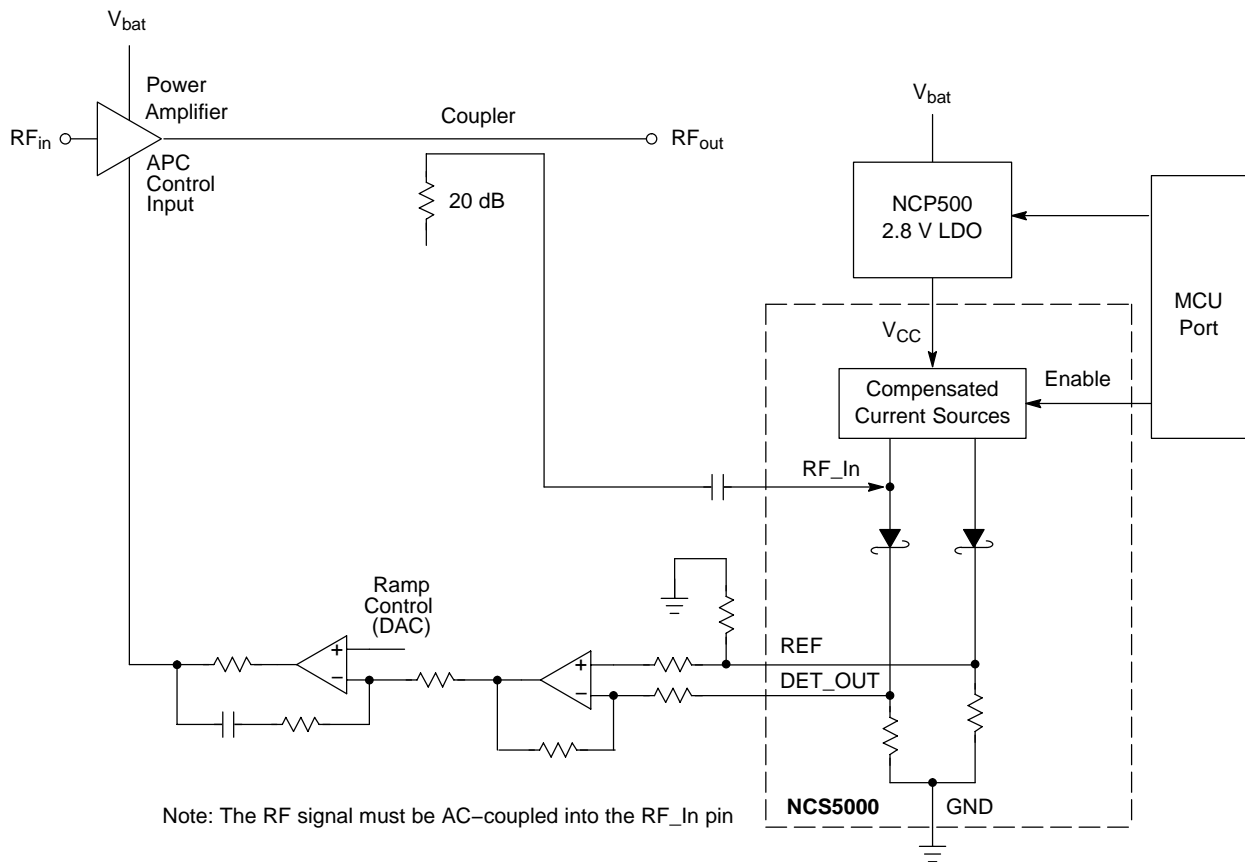

Figure 2. Typical Application Block Diagram

NCS5000

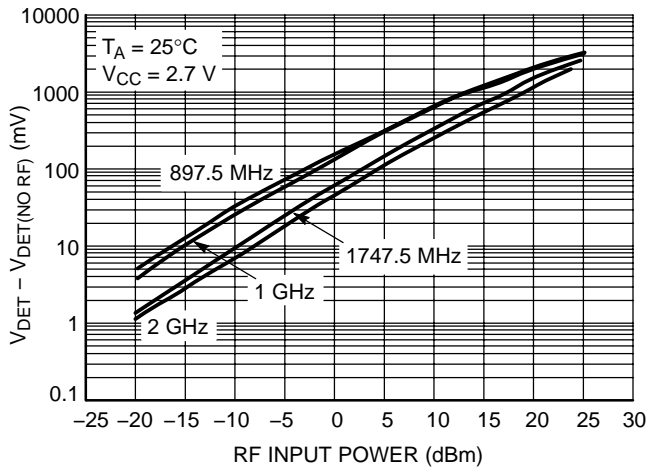

Figure 3. Detector Output Voltage vs. RF Input Power

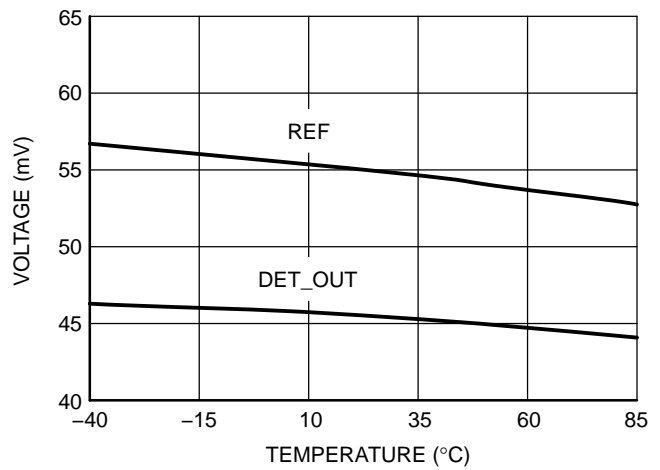

Figure 4. Detector and Reference Output Variation Overtemperature ($V_{CC} = 2.7 V$, No RF Applied)

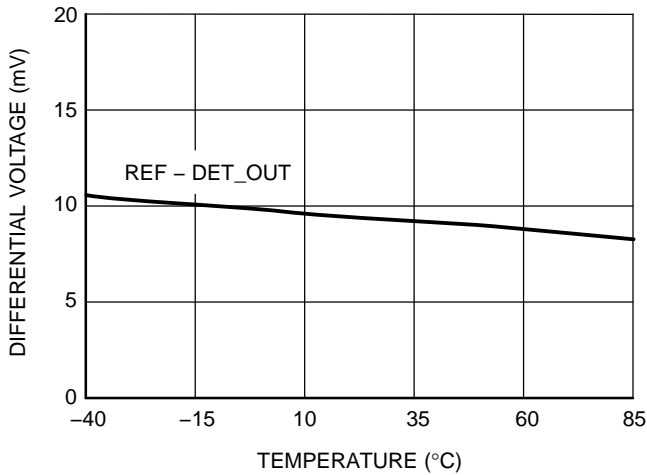

Figure 5. Offset Between RF Detector and Reference Detector Output Voltage Overtemperature ($V_{CC} = 2.7 V$, No RF Applied)

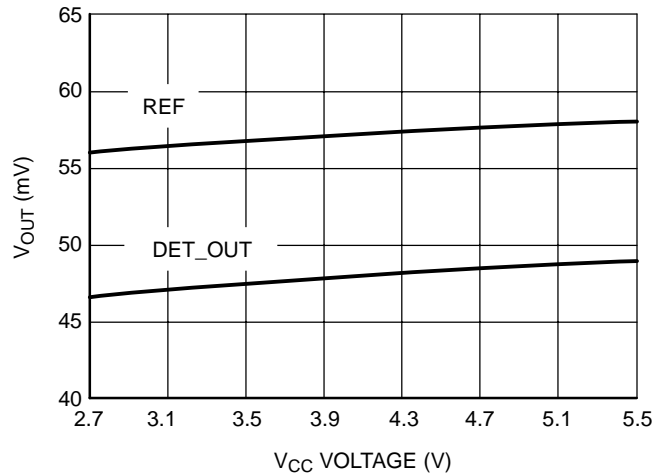

Figure 6. Detector and Reference Output Variation Over V_{CC} Bias ($T_A = 25^\circ C$, No RF Applied)

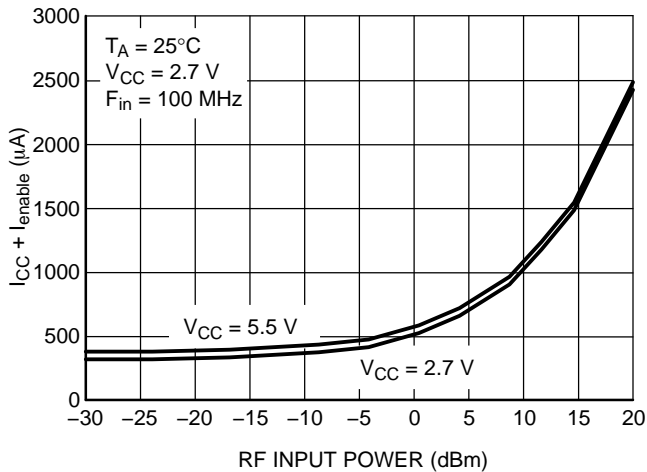

Figure 7. Current Consumption vs. Input Power

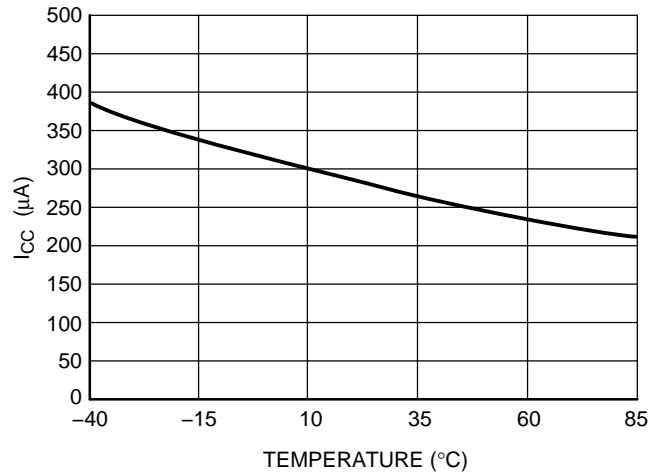

Figure 8. I_{CC} Variation Overtemperature $V_{CC} = 5.5 V$, No RF Applied

NCS5000

APPLICATION INFORMATION

The NCS5000 is an integrated RF Schottky detector designed for use in level detector and power amplifier control circuits. The device is optimized for large signal applications ($P_{in} > -20$ dBm) such as those found in GSM handsets and data modems. This device has been designed for applications that require operation from a single Li-Ion or multi- Ni-MH battery pack. The operating range is 2.7 V – 5.5 V so the device can be powered directly from the battery or a low drop out regulator. To support power sequencing, an Enable circuitry is included which allows the device to be placed into a very low power state ($< 3.0 \mu\text{W}$) when not in use.

In addition to the RF detector, a reference detector is included so the NCS5000 can be used to implement a differential detector. Since the RF and reference detectors are integrated on the same silicon, they track each other tightly over temperature, bias voltage, and process. Each detector is biased with approximately 45 μA of current and there is a built-in offset of 10 mV (nom) between the RF and the Reference Detector.

NCS5000

PACKAGE DIMENSIONS

TSOP-6
SN SUFFIX
CASE 318G-02
ISSUE M

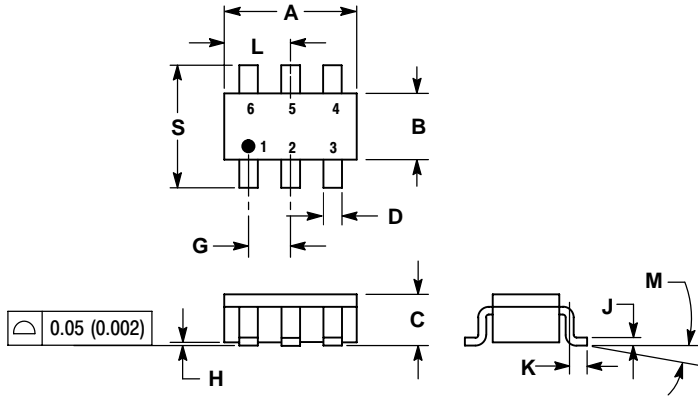

NOTES:

1. DIMENSIONING AND TOLERANCING PER ANSI Y14.5M, 1982.
2. CONTROLLING DIMENSION: MILLIMETER.
3. MAXIMUM LEAD THICKNESS INCLUDES LEAD FINISH THICKNESS. MINIMUM LEAD THICKNESS IS THE MINIMUM THICKNESS OF BASE MATERIAL.
4. DIMENSIONS A AND B DO NOT INCLUDE MOLD FLASH, PROTRUSIONS, OR GATE BURRS.

DIM	MILLIMETERS		INCHES	
	MIN	MAX	MIN	MAX
A	2.90	3.10	0.1142	0.1220
B	1.30	1.70	0.0512	0.0669
C	0.90	1.10	0.0354	0.0433
D	0.25	0.50	0.0098	0.0197
G	0.85	1.05	0.0335	0.0413
H	0.013	0.100	0.0005	0.0040
J	0.10	0.26	0.0040	0.0102
K	0.20	0.60	0.0079	0.0236
L	1.25	1.55	0.0493	0.0610
M	0°	10°	0°	10°
S	2.50	3.00	0.0985	0.1181

SOLDERING FOOTPRINT

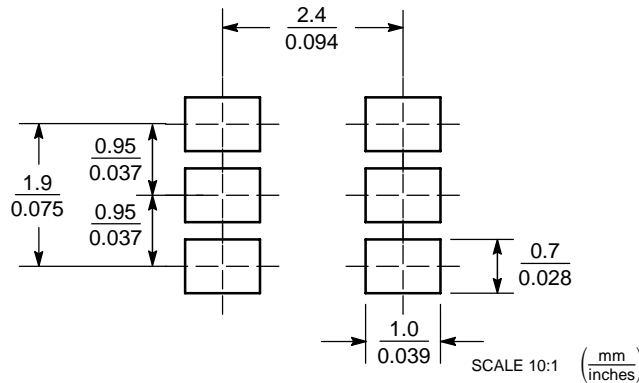

ON Semiconductor and are registered trademarks of Semiconductor Components Industries, LLC (SCILLC). SCILLC reserves the right to make changes without further notice to any products herein. SCILLC makes no warranty, representation or guarantee regarding the suitability of its products for any particular purpose, nor does SCILLC assume any liability arising out of the application or use of any product or circuit, and specifically disclaims any and all liability, including without limitation special, consequential or incidental damages. "Typical" parameters which may be provided in SCILLC data sheets and/or specifications can and do vary in different applications and actual performance may vary over time. All operating parameters, including "Typicals" must be validated for each customer application by customer's technical experts. SCILLC does not convey any license under its patent rights nor the rights of others. SCILLC products are not designed, intended, or authorized for use as components in systems intended for surgical implant into the body, or other applications intended to support or sustain life, or for any other application in which the failure of the SCILLC product could create a situation where personal injury or death may occur. Should Buyer purchase or use SCILLC products for any such unintended or unauthorized application, Buyer shall indemnify and hold SCILLC and its officers, employees, subsidiaries, affiliates, and distributors harmless against all claims, costs, damages, and expenses, and reasonable attorney fees arising out of, directly or indirectly, any claim of personal injury or death associated with such unintended or unauthorized use, even if such claim alleges that SCILLC was negligent regarding the design or manufacture of the part. SCILLC is an Equal Opportunity/Affirmative Action Employer. This literature is subject to all applicable copyright laws and is not for resale in any manner.

PUBLICATION ORDERING INFORMATION

LITERATURE FULFILLMENT:
Literature Distribution Center for ON Semiconductor
P.O. Box 61312, Phoenix, Arizona 85082-1312 USA
Phone: 480-829-7710 or 800-344-3860 Toll Free USA/Canada
Fax: 480-829-7709 or 800-344-3867 Toll Free USA/Canada
Email: orderlit@onsemi.com

N. American Technical Support: 800-282-9855 Toll Free USA/Canada

Japan: ON Semiconductor, Japan Customer Focus Center
2-9-1 Kamimeguro, Meguro-ku, Tokyo, Japan 153-0051
Phone: 81-3-5773-3850

ON Semiconductor Website: <http://onsemi.com>

Order Literature: <http://www.onsemi.com/litorder>

For additional information, please contact your local Sales Representative.

Looking for pricing, stock, or lifecycle information?

Click below to explore more details on WIN SOURCE:

 [View NCS500SNT1G on WIN SOURCE](#)

 [ON Semiconductor](#) Information

Optimize Your Supply Chain with WIN SOURCE Solutions

-  Global Sourcing Solution
-  Obsolete Management
-  Cost Control Management
-  Shortage Management
-  Alternative Solution
-  Excess Inventory Management