



**THE DATASHEET OF
SN75LVDS9637D**



SN75LVDS32, SN75LVDS9637 HIGH-SPEED DIFFERENTIAL LINE RECEIVERS

SLLS360B – JUNE 1999 – REVISED JUNE 2001

- Meets or Exceeds the Requirements of ANSI TIA/EIA-644 Standard
- Operates With a Single 3.3-V Supply
- Designed for Signaling Rate of up to 155 Mbps
- Differential Input Thresholds ± 100 mV Max
- Low-Voltage TTL (LVTTTL) Logic Output Levels
- Open-Circuit Fail Safe
- Characterized For Operation From 0°C to 70°C

SN75LVDS32D (Marked as 75LVDS32)
SN75LVDS32PW (Marked as DS32)
(TOP VIEW)

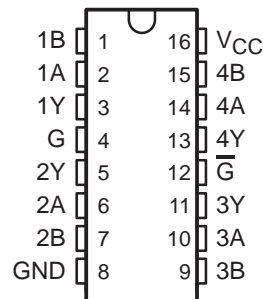

description

The SN75LVDS32 and SN75LVDS9637 are differential line receivers that implement the electrical characteristics of low-voltage differential signaling (LVDS). This signaling technique lowers the output voltage levels of 5-V differential standard levels (such as EIA/TIA-422B) to reduce the power, increase the switching speeds, and allow operation with a 3.3-V supply rail. Any of the four differential receivers provides a valid logical output state with a ± 100 mV allow operation with a differential input voltage within the input common-mode voltage range. The input common-mode voltage range allows 1 V of ground potential difference between two LVDS nodes.

The intended application of these devices and signaling technique is both point-to-point and multidrop (one driver and multiple receivers) data transmission over controlled impedance media of approximately 100 Ω . The transmission media may be printed-circuit board traces, backplanes, or cables. The ultimate rate and distance of data transfer is dependent upon the attenuation characteristics of the media and the noise coupling to the environment.

The SN75LVDS32 and SN75LVDS9637 are characterized for operation from 0°C to 70°C .

SN75LVDS9637D (Marked as DF637 or 7L9637)
SN75LVDS9637DGK (Marked as AXI)
(TOP VIEW)

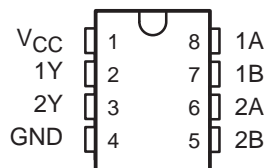

Please be aware that an important notice concerning availability, standard warranty, and use in critical applications of Texas Instruments semiconductor products and disclaimers thereto appears at the end of this data sheet.

PRODUCTION DATA information is current as of publication date. Products conform to specifications per the terms of Texas Instruments standard warranty. Production processing does not necessarily include testing of all parameters.

**TEXAS
INSTRUMENTS**

POST OFFICE BOX 655303 • DALLAS, TEXAS 75265

Copyright © 2001 Texas Instruments Incorporated

SN75LVDS32, SN75LVDS9637 HIGH-SPEED DIFFERENTIAL LINE RECEIVERS

SLLS360B – JUNE 1999 – REVISED JUNE 2001

logic diagram

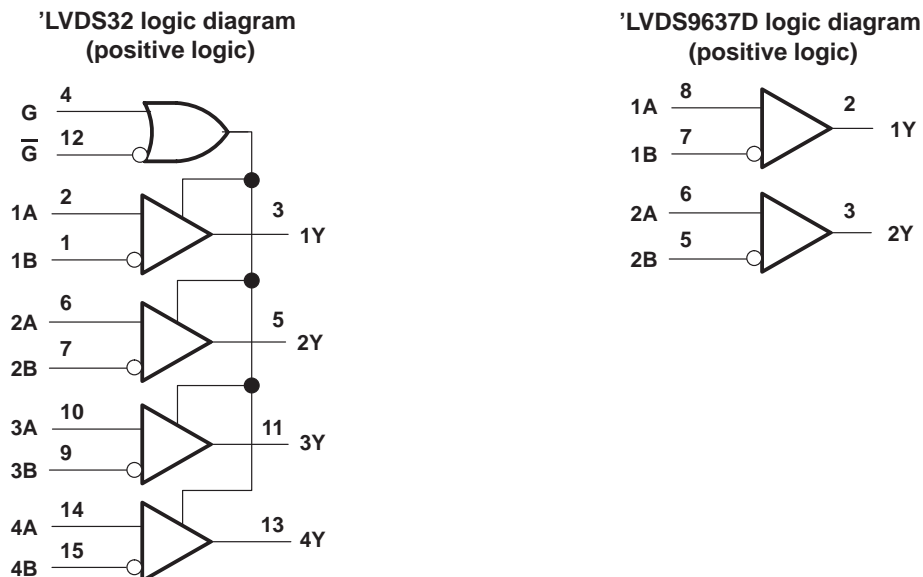

Function Tables

SN75LVDS32			
DIFFERENTIAL INPUT	ENABLES		OUTPUT
A, B	G	\overline{G}	Y
$V_{ID} \geq 100 \text{ mV}$	H	X	H
	X	L	H
$-100 \text{ mV} < V_{ID} < 100 \text{ mV}$	H	X	?
	X	L	?
$V_{ID} \leq -100 \text{ mV}$	H	X	L
	X	L	L
X	L	H	Z
Open	H	X	H
	X	L	H

H = high level, L = low level, X = irrelevant,
Z = high impedance (off), ? = indeterminate

logic symbol†

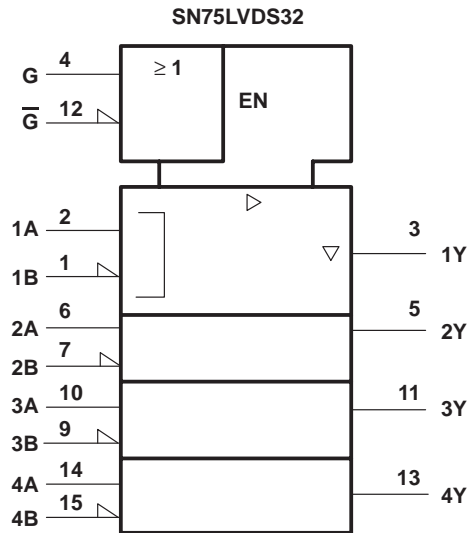

† This symbol is in accordance with ANSI/IEEE Std 91-1984 and IEC Publication 617-12.

Function Table

SN75LVDS9637

DIFFERENTIAL INPUT	OUTPUT
A, B	Y
$V_{ID} \geq 100 \text{ mV}$	H
$-100 \text{ mV} < V_{ID} < 100 \text{ mV}$?
$V_{ID} \leq -100 \text{ mV}$	L
Open	H

H = high level, L = low level, ? = indeterminate

logic symbol†

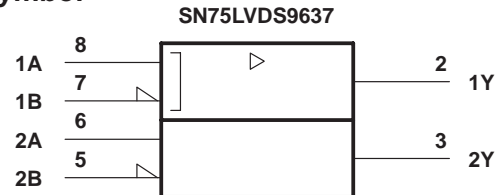

† This symbol is in accordance with ANSI/IEEE Std 91-1984 and IEC Publication 617-12.

SN75LVDS32, SN75LVDS9637 HIGH-SPEED DIFFERENTIAL LINE RECEIVERS

SLLS360B – JUNE 1999 – REVISED JUNE 2001

equivalent input and output schematic diagrams

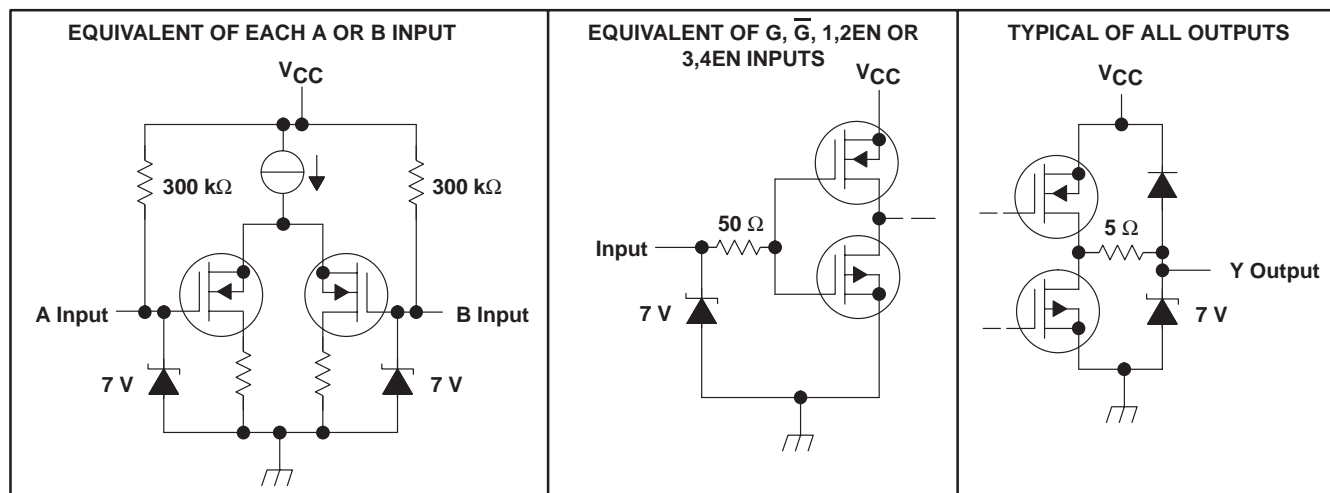

absolute maximum ratings over operating free-air temperature range (unless otherwise noted)†

Supply voltage range, V_{CC} (see Note 1)	–0.5 V to 4 V
Input voltage range, V_I	–0.5 V to $V_{CC} + 0.5$ V
Input voltage range, V_I (A or B)	–0.5 V to 4 V
Continuous total power dissipation	See Dissipation Rating Table
Storage temperature range, T_{stg}	–65°C to 150°C
Lead temperature 1,6 mm (1/16 inch) from case for 10 seconds	260°C

† Stresses beyond those listed under “absolute maximum ratings” may cause permanent damage to the device. These are stress ratings only, and functional operation of the device at these or any other conditions beyond those indicated under “recommended operating conditions” is not implied. Exposure to absolute-maximum-rated conditions for extended periods may affect device reliability.

NOTE 1: All voltages, except differential I/O bus voltages, are with respect to the network ground terminal.

DISSIPATION RATING TABLE

PACKAGE	$T_A \leq 25^\circ\text{C}$ POWER RATING	DERATING FACTOR‡ ABOVE $T_A = 25^\circ\text{C}$	$T_A = 70^\circ\text{C}$ POWER RATING
D (8)	725 mW	5.8 mW/°C	464 mW
D (16)	950 mW	7.6 mW/°C	608 mW
PW	774 mW	6.2 mW/°C	496 mW
DGK	425 mW	3.4 mW/°C	272 mW

‡ This is the inverse of the junction-to-ambient thermal resistance when board mounted and with no air flow.

recommended operating conditions

		MIN	NOM	MAX	UNIT
Supply voltage, V_{CC}		3	3.3	3.6	V
High-level input voltage, V_{IH}	G, \overline{G}	2			V
Low-level input voltage, V_{IL}	G, \overline{G}			0.8	V
Magnitude of differential input voltage, $ V_{ID} $		0.1		0.6	V
Common-mode input voltage, V_{IC} (see Figure 1)		$\frac{ V_{ID} }{2}$	$2.4 - \frac{ V_{ID} }{2}$		V
			$V_{CC} - 0.8$		V
Operating free-air temperature, T_A		0		70	°C

COMMON-MODE INPUT VOLTAGE RANGE
vs
DIFFERENTIAL INPUT VOLTAGE

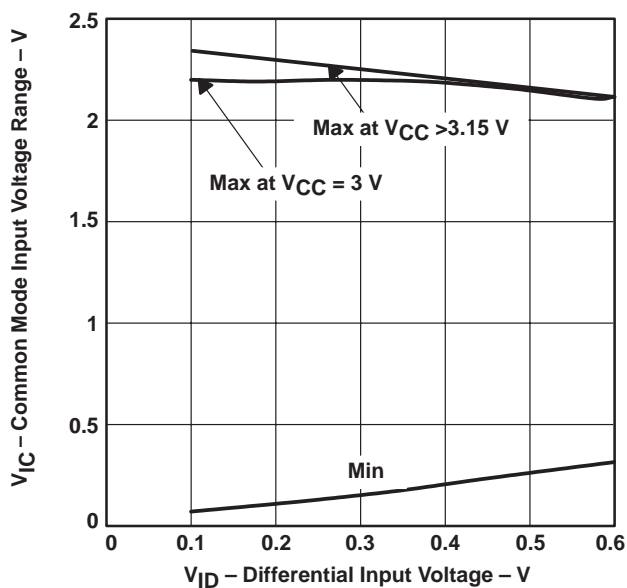

Figure 1. V_{IC} Versus V_{ID} and V_{CC}

SN75LVDS32, SN75LVDS9637 HIGH-SPEED DIFFERENTIAL LINE RECEIVERS

SLLS360B – JUNE 1999 – REVISED JUNE 2001

SN75LVDSxxxx electrical characteristics over recommended operating conditions (unless otherwise noted)

PARAMETER		TEST CONDITIONS	SN75LVDS32, SN75LVDS9637			UNIT	
			MIN	TYP†	MAX		
V _I TH+	Positive-going differential input voltage threshold	See Figure 2 and Table 1			100	mV	
V _I TH-	Negative-going differential input voltage threshold‡		-100			mV	
V _O H	High-level output voltage	I _{OH} = -8 mA	2.4			V	
V _O L	Low-level output voltage	I _{OL} = 8 mA			0.4	V	
I _{CC}	Supply current	SN75LVDS32	Enabled, No load		10	18	mA
			Disabled		0.25	0.5	
		SN75LVDS9637	No load		5.5	10	
I _I	Input current (A or B inputs)	V _I = 0		-2	-10	-20	μA
		V _I = 2.4 V		-1.2	-3		
I _I (OFF)	Power-off input current (A or B inputs)	V _{CC} = 0, V _I = 3.6 V		6	20	μA	
I _I H	High-level input current (G, or \overline{G} inputs)	V _I H = 2 V			10	μA	
I _I L	Low-level input current (G, or \overline{G} inputs)	V _I L = 0.8 V			10	μA	
I _{OZ}	High-impedance output current	V _O = 0 or V _{CC}			±10	μA	

† All typical values are at T_A = 25°C and with V_{CC} = 3.3 V.

‡ The algebraic convention, in which the less positive (more negative) limit is designated minimum, is used in this data sheet for the negative-going differential input voltage threshold only.

SN75LVDSxxxx switching characteristics over recommended operating conditions (unless otherwise noted)

PARAMETER		TEST CONDITIONS	SN75LVDS32, SN75LVDS9637			UNIT
			MIN	TYP†	MAX	
t _p LH	Propagation delay time, low-to-high-level output	C _L = 100 pF, See Figure 3		2.1	6	ns
t _p HL	Propagation delay time, high-to-low-level output			2.1	6	ns
t _{sk} (p)	Pulse skew (t _p HL - t _p LH)			0.6	1.5	ns
t _{sk} (o)	Channel-to-channel output skew†			0.7	1.5	ns
t _{sk} (pp)	Part-to-part skew‡				0.6	ns
t _r	Output signal rise time, 20% to 80%				0.6	ns
t _f	Output signal fall time, 80% to 20%				1	ns
t _p HZ	Propagation delay time, high-level-to-high-impedance output	See Figure 4			25	ns
t _p LZ	Propagation delay time, low-level-to-high-impedance output				25	ns
t _p ZH	Propagation delay time, high-impedance-to-high-level output				25	ns
t _p ZL	Propagation delay time, high-impedance-to-low-level output				25	ns

† All typical values are at 25°C and with a 3.3-V supply.

‡ t_{sk}(p) is the magnitude of the time difference between the high-to-low and low-to-high propagation delay times at an output

§ t_{sk}(o) is the magnitude of the time difference between the outputs of a single device with all of their inputs connected together.

¶ t_{sk}(pp) is the magnitude of the difference in propagation delay times between any specified terminals of two devices when both devices operate with the same supply voltages, same temperature, and have identical packages and test circuits.



PARAMETER MEASUREMENT INFORMATION

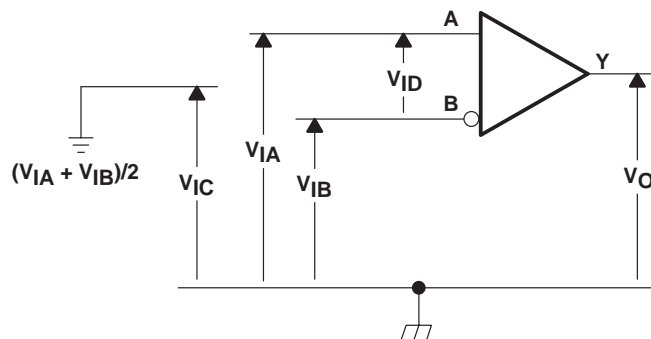

Figure 2. Voltage Definitions

Table 1. Receiver Minimum and Maximum Input Threshold Test Voltages

APPLIED VOLTAGES		RESULTING DIFFERENTIAL INPUT VOLTAGE	RESULTING COMMON-MODE INPUT VOLTAGE
V_{IA}	V_{IB}	V_{ID}	V_{IC}
1.25 V	1.15 V	100 mV	1.2 V
1.15 V	1.25 V	-100 mV	1.2 V
2.4 V	2.3 V	100 mV	2.35 V
2.3 V	2.4 V	-100 mV	2.35 V
0.1 V	0 V	100 mV	0.05 V
0 V	0.1 V	-100 mV	0.05 V
1.5 V	0.9 V	600 mV	1.2 V
0.9 V	1.5 V	-600 mV	1.2 V
2.4 V	1.8 V	600 mV	2.1 V
1.8 V	2.4 V	-600 mV	2.1 V
0.6 V	0 V	600 mV	0.3 V
0 V	0.6 V	-600 mV	0.3 V

SN75LVDS32, SN75LVDS9637 HIGH-SPEED DIFFERENTIAL LINE RECEIVERS

SLLS360B – JUNE 1999 – REVISED JUNE 2001

PARAMETER MEASUREMENT INFORMATION

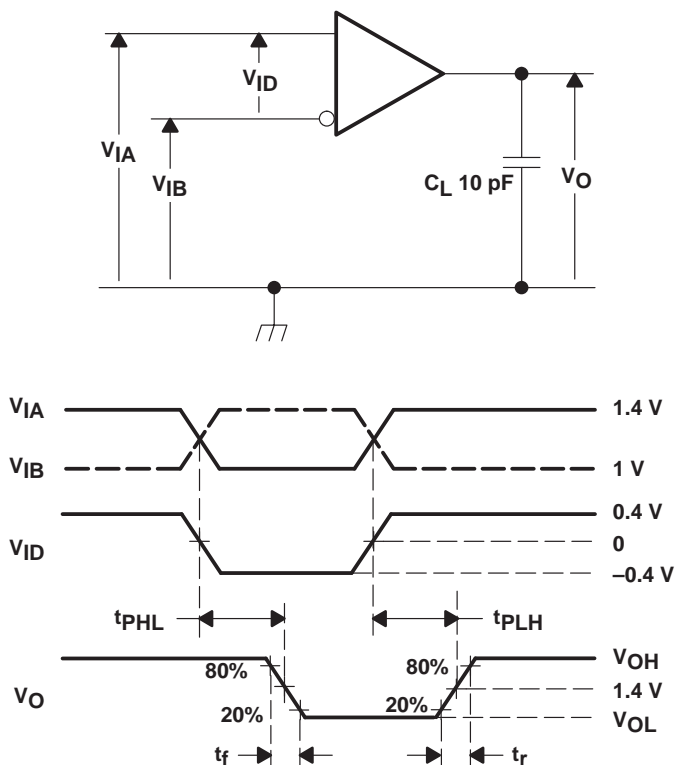

- NOTES: A. All input pulses are supplied by a generator having the following characteristics: t_r or $t_f \leq 1 \text{ ns}$, pulse repetition rate (PRR) = 50 Mpps, pulse width = $10 \pm 0.2 \text{ ns}$.
 B. C_L includes instrumentation and fixture capacitance within 6 mm of the D.U.T.

Figure 3. Timing Test Circuit and Wave Forms

PARAMETER MEASUREMENT INFORMATION

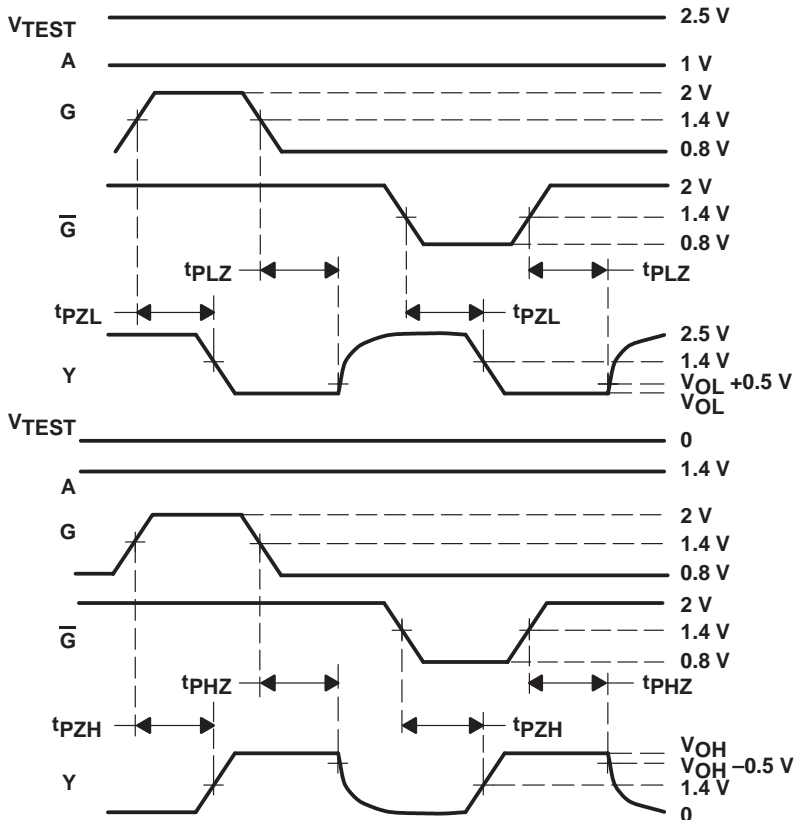
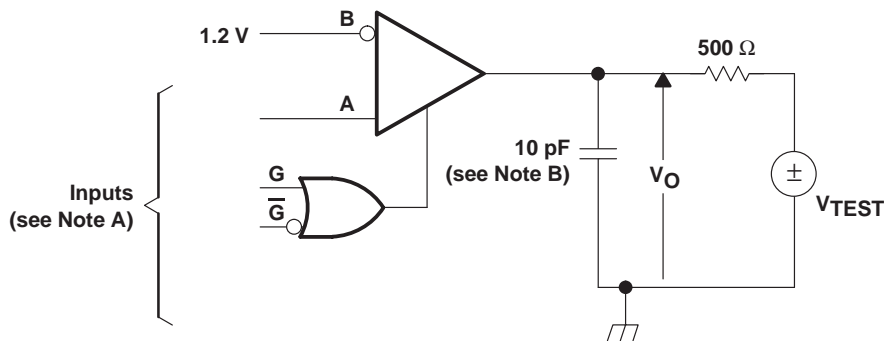

- NOTES: A. All input pulses are supplied by a generator having the following characteristics: t_r or $t_f \leq 1$ ns, pulse repetition rate (PRR) = 0.5 Mpps, pulse width = 500 ± 10 ns.
B. C_L includes instrumentation and fixture capacitance within 6 mm of the D.U.T.

Figure 4. Enable/Disable Time Test Circuit and Wave Forms

SN75LVDS32, SN75LVDS9637 HIGH-SPEED DIFFERENTIAL LINE RECEIVERS

SLLS360B – JUNE 1999 – REVISED JUNE 2001

APPLICATION INFORMATION

using an LVDS receiver with RS-422 data

Receipt of data from a TIA/EIA-422 line driver may be accomplished using a TIA/EIA-644 line receiver with the addition of an attenuator circuit. This technique gives the user a very high-speed and low-power 422 receiver.

If the ground noise between the transmitter and receiver is not a concern (less than ± 1 V), the answer can be as simple as shown below in Figure 5. The use of a resistor divider circuit in front of the LVDS receiver attenuates the 422 differential signal to LVDS levels.

The resistors present a total differential load of $100\ \Omega$ to match the characteristic impedance of the transmission line and to reduce the signal 10:1. The maximum 422 differential output signal or 6 V is reduced to 600 mV. The high input impedance of the LVDS receiver prevents input bias offsets and maintains a better than 200-mV differential input voltage threshold at the inputs to the divider. This circuit is used in front of each LVDS channel that also receives 422 signals.

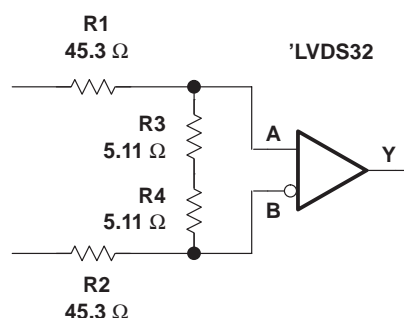

NOTE A: The components used were standard values.

R1, R2 = NRC12F45R3TR, NIC Components, 45.3 Ohm, 1/8W, 1%, 1206 Package

R3, R4 = NRC12F5R11TR, NIC Components, 5.11 Ohm, 1/8W, 1%, 1206 Package

The resistor values do not need to be 1% tolerance. However, it can be difficult locating a supplier of resistors having values less than $100\ \Omega$ in stock and readily available. The user may find other suppliers with comparable parts having tolerances of 5% or even 10%. These parts are adequate for use in this circuit.

Figure 5. RS-422 Data Input to an LVDS Receiver Under Low Ground Noise Conditions

If ground noise between the RS-422 driver and LVDS receiver is a concern, then the common-mode voltage must be attenuated. The circuit must then be modified to connect the node between R3 and R4 to the LVDS receiver ground. This modification to the circuit increases the common-mode voltage from ± 1 V to greater than ± 4.5 V.

APPLICATIONS INFORMATION

The devices are generally used as building blocks for high-speed point-to-point data transmission where ground differences are less than 1 V. Devices can interoperate with RS-422, PECL, and IEEE-P1596. Drivers/receivers approach ECL speeds without the power and dual supply requirements.

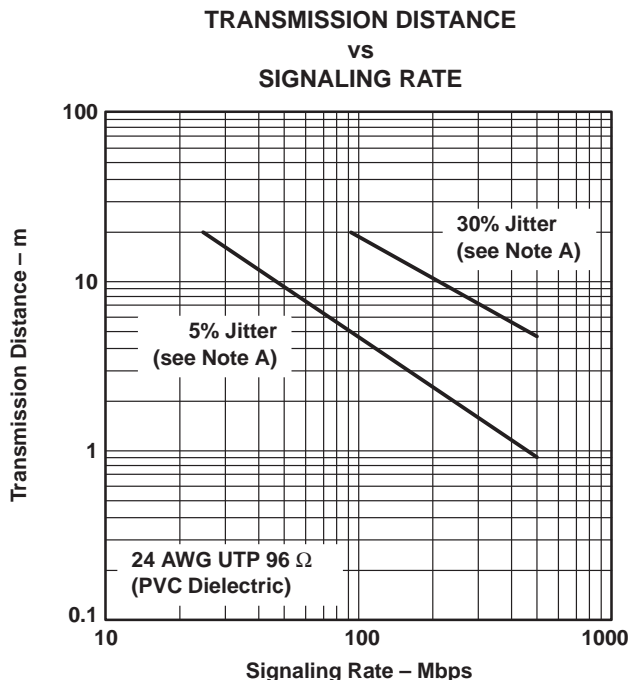

NOTE A: This parameter is the percentage of distortion of the unit interval (UI) with a pseudorandom data pattern.

Figure 6. Typical Transmission Distance vs Signaling Rate

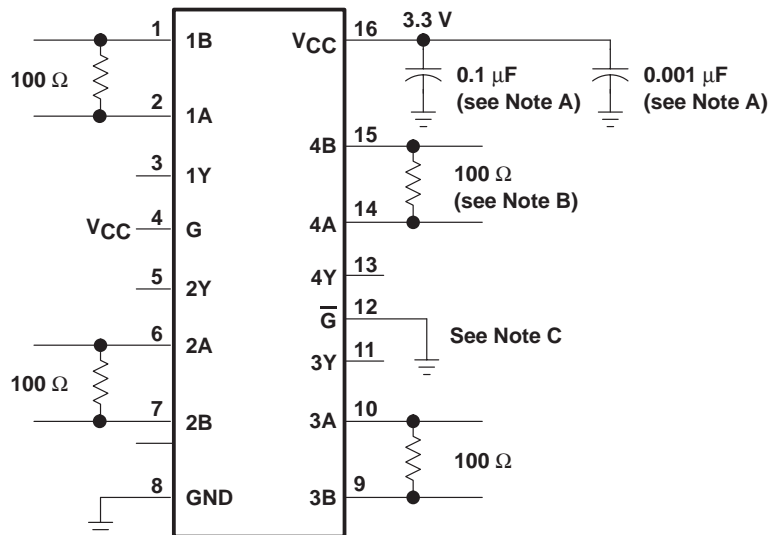

- NOTES: A. Place a 0.1 μ F and a 0.001 μ F Z5U ceramic, mica or polystyrene dielectric, 0805 size, chip capacitor between V_{CC} and the ground plane. The capacitors should be located as close as possible to the device terminals.
 B. The termination resistance value should match the nominal characteristic impedance of the transmission media with $\pm 10\%$.
 C. Unused enable inputs should be tied to V_{CC} or GND as appropriate.

Figure 7. Typical Application Circuit Schematic

SN75LVDS32, SN75LVDS9637 HIGH-SPEED DIFFERENTIAL LINE RECEIVERS

SLLS360B – JUNE 1999 – REVISED JUNE 2001

APPLICATION INFORMATION

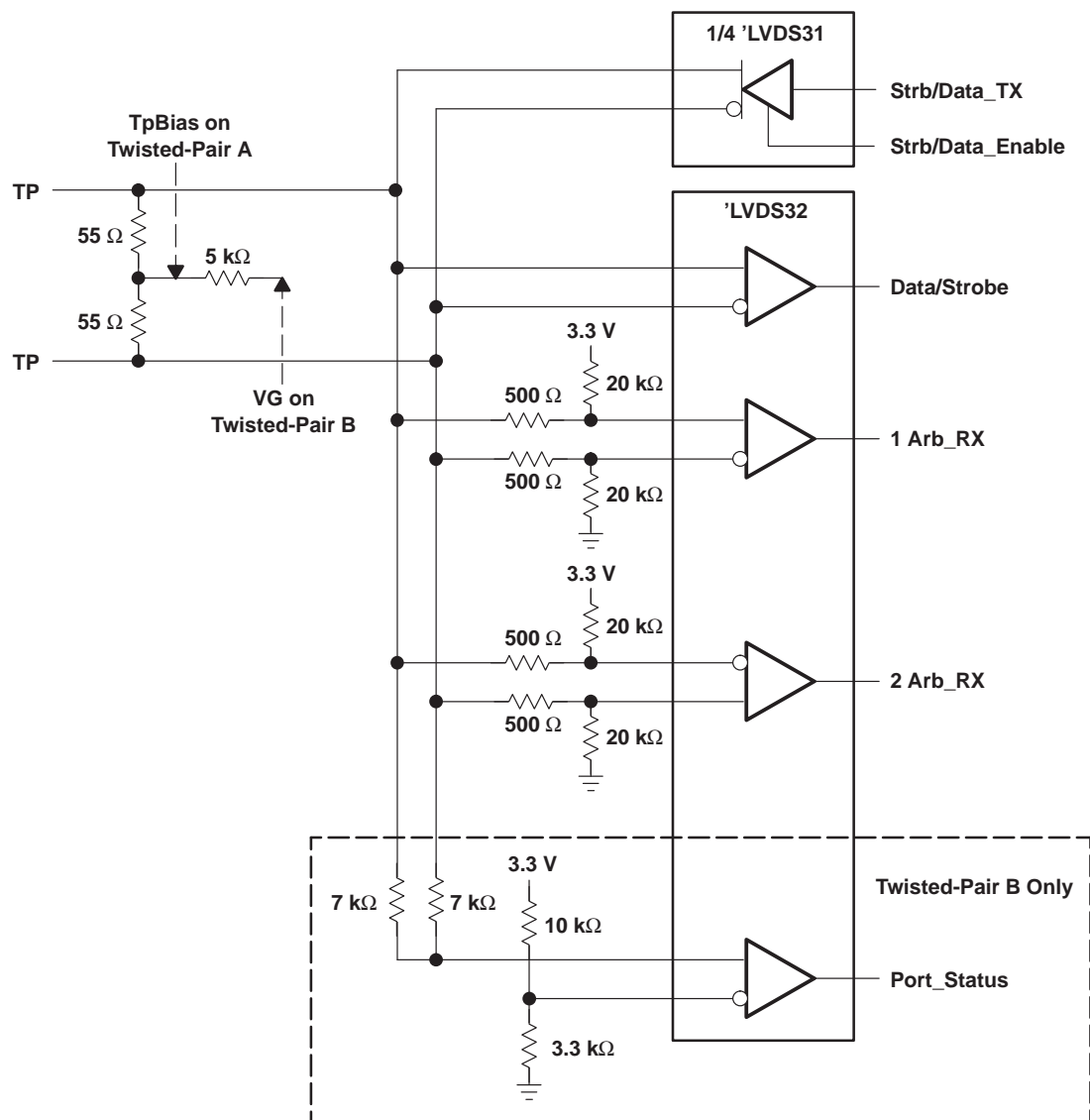

- NOTES: A. Resistors are leadless thick-film (0603) 5% tolerance.
 B. Decoupling capacitance is not shown but recommended.
 C. V_{CC} is 3 V to 3.6 V.
 D. The differential output voltage of the 'LVDS31 can exceed that allowed by IEEE1394.

Figure 8. 100-Mbps IEEE 1394 Transceiver

APPLICATION INFORMATION

fail safe

One of the most common problems with differential signaling applications is how the system responds when no differential voltage is present on the signal pair. The LVDS receiver is like most differential line receivers, in that its output logic state can be indeterminate when the differential input voltage is between -100 mV and 100 mV if it is within its recommended input common-mode voltage range. TI's LVDS receiver is different in how it handles the open-input circuit situation, however.

Open-circuit means that there is little or no input current to the receiver from the data line itself. This could be when the driver is in a high-impedance state or the cable is disconnected. When this occurs, the LVDS receiver will pull each line of the signal pair to near V_{CC} through 300 -k Ω resistors as shown in Figure 9. The fail-safe feature uses an AND gate with input voltage thresholds at about 2.3 V to detect this condition and force the output to a high level, regardless of the differential input voltage.

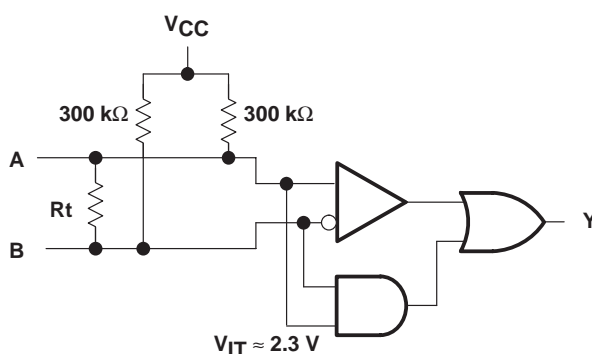

Figure 9. Open-Circuit Fail Safe of the LVDS Receiver

It is only under these conditions that the output of the receiver will be valid with less than a 100 -mV differential input voltage magnitude. The presence of the termination resistor, R_t , does not affect the fail-safe function as long as it is connected as shown in the figure. Other termination circuits may allow a dc current to ground that could defeat the pullup currents from the receiver and the fail-safe feature.

SN75LVDS32, SN75LVDS9637 HIGH-SPEED DIFFERENTIAL LINE RECEIVERS

SLLS360B – JUNE 1999 – REVISED JUNE 2001

APPLICATION INFORMATION

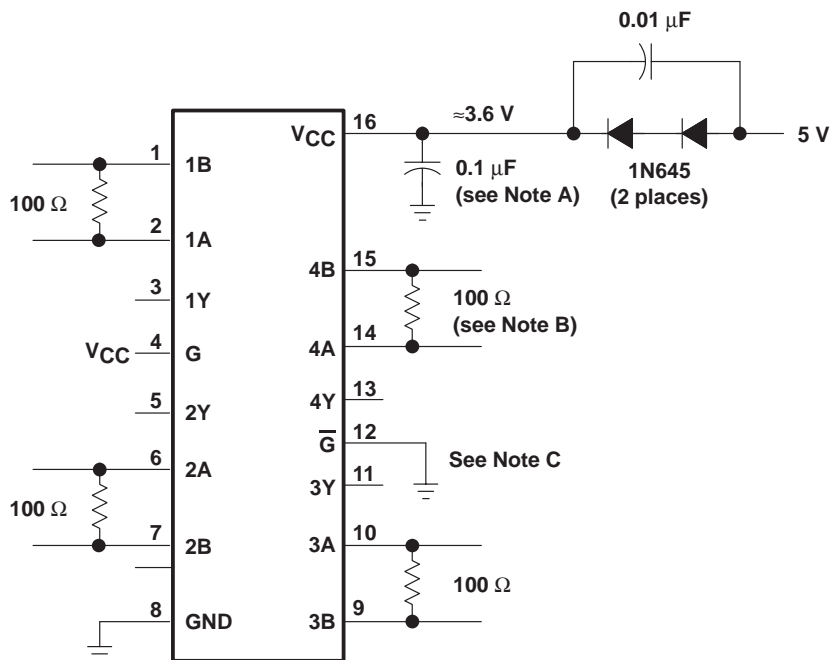

- NOTES: A. Place a 0.1 µF Z5U ceramic, mica or polystyrene dielectric, 0805 size, chip capacitor between V_{CC} and the ground plane. The capacitor should be located as close as possible to the device terminals.
- B. The termination resistance value should match the nominal characteristic impedance of the transmission media with ±10%.
- C. Unused enable inputs should be tied to V_{CC} or GND as appropriate.

Figure 10. Operation With 5-V Supply

related information

IBIS modeling is available for this device. Please contact the local TI sales office or the TI Web site at www.ti.com for more information.

For more application guidelines, please see the following documents:

- *Low-Voltage Differential Signalling Design Notes* (TI literature SLLA014)
- *Interface Circuits for TIA/EIA-644 (LVDS)* (TI literature SLLA038)
- *Reducing EMI with LVDS* (TI literature SLLA030)
- *Slew Rate Control of LVDS Circuits* (TI literature SLLA034)
- *Using an LVDS Receiver with RS-422 Data* (TI literature SLLA031)
- *Evaluating the LVDS EVM* (TI literature SLLA033)

PACKAGING INFORMATION

Orderable Device	Status (1)	Package Type	Package Drawing	Pins	Package Qty	Eco Plan (2)	Lead/Ball Finish (6)	MSL Peak Temp (3)	Op Temp (°C)	Device Marking (4/5)	Samples
SN75LVDS32D	ACTIVE	SOIC	D	16	40	Green (RoHS & no Sb/Br)	CU NIPDAU	Level-1-260C-UNLIM	0 to 70	75LVDS32	Samples
SN75LVDS32DR	ACTIVE	SOIC	D	16	2500	Green (RoHS & no Sb/Br)	CU NIPDAU	Level-1-260C-UNLIM	0 to 70	75LVDS32	Samples
SN75LVDS9637D	ACTIVE	SOIC	D	8	75	Green (RoHS & no Sb/Br)	CU NIPDAU	Level-1-260C-UNLIM	0 to 70	DF637	Samples

(1) The marketing status values are defined as follows:

ACTIVE: Product device recommended for new designs.

LIFEBUY: TI has announced that the device will be discontinued, and a lifetime-buy period is in effect.

NRND: Not recommended for new designs. Device is in production to support existing customers, but TI does not recommend using this part in a new design.

PREVIEW: Device has been announced but is not in production. Samples may or may not be available.

OBSELETE: TI has discontinued the production of the device.

(2) Eco Plan - The planned eco-friendly classification: Pb-Free (RoHS), Pb-Free (RoHS Exempt), or Green (RoHS & no Sb/Br) - please check <http://www.ti.com/productcontent> for the latest availability information and additional product content details.

TBD: The Pb-Free/Green conversion plan has not been defined.

Pb-Free (RoHS): TI's terms "Lead-Free" or "Pb-Free" mean semiconductor products that are compatible with the current RoHS requirements for all 6 substances, including the requirement that lead not exceed 0.1% by weight in homogeneous materials. Where designed to be soldered at high temperatures, TI Pb-Free products are suitable for use in specified lead-free processes.

Pb-Free (RoHS Exempt): This component has a RoHS exemption for either 1) lead-based flip-chip solder bumps used between the die and package, or 2) lead-based die adhesive used between the die and leadframe. The component is otherwise considered Pb-Free (RoHS compatible) as defined above.

Green (RoHS & no Sb/Br): TI defines "Green" to mean Pb-Free (RoHS compatible), and free of Bromine (Br) and Antimony (Sb) based flame retardants (Br or Sb do not exceed 0.1% by weight in homogeneous material)

(3) MSL, Peak Temp. - The Moisture Sensitivity Level rating according to the JEDEC industry standard classifications, and peak solder temperature.

(4) There may be additional marking, which relates to the logo, the lot trace code information, or the environmental category on the device.

(5) Multiple Device Markings will be inside parentheses. Only one Device Marking contained in parentheses and separated by a "~" will appear on a device. If a line is indented then it is a continuation of the previous line and the two combined represent the entire Device Marking for that device.

(6) Lead/Ball Finish - Orderable Devices may have multiple material finish options. Finish options are separated by a vertical ruled line. Lead/Ball Finish values may wrap to two lines if the finish value exceeds the maximum column width.

Important Information and Disclaimer: The information provided on this page represents TI's knowledge and belief as of the date that it is provided. TI bases its knowledge and belief on information provided by third parties, and makes no representation or warranty as to the accuracy of such information. Efforts are underway to better integrate information from third parties. TI has taken and

continues to take reasonable steps to provide representative and accurate information but may not have conducted destructive testing or chemical analysis on incoming materials and chemicals. TI and TI suppliers consider certain information to be proprietary, and thus CAS numbers and other limited information may not be available for release.

In no event shall TI's liability arising out of such information exceed the total purchase price of the TI part(s) at issue in this document sold by TI to Customer on an annual basis.

OTHER QUALIFIED VERSIONS OF SN75LVDS32 :

- Military: [SN55LVDS32](#)

NOTE: Qualified Version Definitions:

- Military - QML certified for Military and Defense Applications

TAPE AND REEL INFORMATION
REEL DIMENSIONS

TAPE DIMENSIONS

A0	Dimension designed to accommodate the component width
B0	Dimension designed to accommodate the component length
K0	Dimension designed to accommodate the component thickness
W	Overall width of the carrier tape
P1	Pitch between successive cavity centers

TAPE AND REEL INFORMATION

*All dimensions are nominal

Device	Package Type	Package Drawing	Pins	SPQ	Reel Diameter (mm)	Reel Width W1 (mm)	A0 (mm)	B0 (mm)	K0 (mm)	P1 (mm)	W (mm)	Pin1 Quadrant
SN75LVDS32DR	SOIC	D	16	2500	330.0	16.4	6.5	10.3	2.1	8.0	16.0	Q1

TAPE AND REEL BOX DIMENSIONS



*All dimensions are nominal

Device	Package Type	Package Drawing	Pins	SPQ	Length (mm)	Width (mm)	Height (mm)
SN75LVDS32DR	SOIC	D	16	2500	333.2	345.9	28.6

IMPORTANT NOTICE

Texas Instruments Incorporated (TI) reserves the right to make corrections, enhancements, improvements and other changes to its semiconductor products and services per JESD46, latest issue, and to discontinue any product or service per JESD48, latest issue. Buyers should obtain the latest relevant information before placing orders and should verify that such information is current and complete.

TI's published terms of sale for semiconductor products (<http://www.ti.com/sc/docs/stdterms.htm>) apply to the sale of packaged integrated circuit products that TI has qualified and released to market. Additional terms may apply to the use or sale of other types of TI products and services.

Reproduction of significant portions of TI information in TI data sheets is permissible only if reproduction is without alteration and is accompanied by all associated warranties, conditions, limitations, and notices. TI is not responsible or liable for such reproduced documentation. Information of third parties may be subject to additional restrictions. Resale of TI products or services with statements different from or beyond the parameters stated by TI for that product or service voids all express and any implied warranties for the associated TI product or service and is an unfair and deceptive business practice. TI is not responsible or liable for any such statements.

Buyers and others who are developing systems that incorporate TI products (collectively, "Designers") understand and agree that Designers remain responsible for using their independent analysis, evaluation and judgment in designing their applications and that Designers have full and exclusive responsibility to assure the safety of Designers' applications and compliance of their applications (and of all TI products used in or for Designers' applications) with all applicable regulations, laws and other applicable requirements. Designer represents that, with respect to their applications, Designer has all the necessary expertise to create and implement safeguards that (1) anticipate dangerous consequences of failures, (2) monitor failures and their consequences, and (3) lessen the likelihood of failures that might cause harm and take appropriate actions. Designer agrees that prior to using or distributing any applications that include TI products, Designer will thoroughly test such applications and the functionality of such TI products as used in such applications.

TI's provision of technical, application or other design advice, quality characterization, reliability data or other services or information, including, but not limited to, reference designs and materials relating to evaluation modules, (collectively, "TI Resources") are intended to assist designers who are developing applications that incorporate TI products; by downloading, accessing or using TI Resources in any way, Designer (individually or, if Designer is acting on behalf of a company, Designer's company) agrees to use any particular TI Resource solely for this purpose and subject to the terms of this Notice.

TI's provision of TI Resources does not expand or otherwise alter TI's applicable published warranties or warranty disclaimers for TI products, and no additional obligations or liabilities arise from TI providing such TI Resources. TI reserves the right to make corrections, enhancements, improvements and other changes to its TI Resources. TI has not conducted any testing other than that specifically described in the published documentation for a particular TI Resource.

Designer is authorized to use, copy and modify any individual TI Resource only in connection with the development of applications that include the TI product(s) identified in such TI Resource. NO OTHER LICENSE, EXPRESS OR IMPLIED, BY ESTOPPEL OR OTHERWISE TO ANY OTHER TI INTELLECTUAL PROPERTY RIGHT, AND NO LICENSE TO ANY TECHNOLOGY OR INTELLECTUAL PROPERTY RIGHT OF TI OR ANY THIRD PARTY IS GRANTED HEREIN, including but not limited to any patent right, copyright, mask work right, or other intellectual property right relating to any combination, machine, or process in which TI products or services are used. Information regarding or referencing third-party products or services does not constitute a license to use such products or services, or a warranty or endorsement thereof. Use of TI Resources may require a license from a third party under the patents or other intellectual property of the third party, or a license from TI under the patents or other intellectual property of TI.

TI RESOURCES ARE PROVIDED "AS IS" AND WITH ALL FAULTS. TI DISCLAIMS ALL OTHER WARRANTIES OR REPRESENTATIONS, EXPRESS OR IMPLIED, REGARDING RESOURCES OR USE THEREOF, INCLUDING BUT NOT LIMITED TO ACCURACY OR COMPLETENESS, TITLE, ANY EPIDEMIC FAILURE WARRANTY AND ANY IMPLIED WARRANTIES OF MERCHANTABILITY, FITNESS FOR A PARTICULAR PURPOSE, AND NON-INFRINGEMENT OF ANY THIRD PARTY INTELLECTUAL PROPERTY RIGHTS. TI SHALL NOT BE LIABLE FOR AND SHALL NOT DEFEND OR INDEMNIFY DESIGNER AGAINST ANY CLAIM, INCLUDING BUT NOT LIMITED TO ANY INFRINGEMENT CLAIM THAT RELATES TO OR IS BASED ON ANY COMBINATION OF PRODUCTS EVEN IF DESCRIBED IN TI RESOURCES OR OTHERWISE. IN NO EVENT SHALL TI BE LIABLE FOR ANY ACTUAL, DIRECT, SPECIAL, COLLATERAL, INDIRECT, PUNITIVE, INCIDENTAL, CONSEQUENTIAL OR EXEMPLARY DAMAGES IN CONNECTION WITH OR ARISING OUT OF TI RESOURCES OR USE THEREOF, AND REGARDLESS OF WHETHER TI HAS BEEN ADVISED OF THE POSSIBILITY OF SUCH DAMAGES.

Unless TI has explicitly designated an individual product as meeting the requirements of a particular industry standard (e.g., ISO/TS 16949 and ISO 26262), TI is not responsible for any failure to meet such industry standard requirements.

Where TI specifically promotes products as facilitating functional safety or as compliant with industry functional safety standards, such products are intended to help enable customers to design and create their own applications that meet applicable functional safety standards and requirements. Using products in an application does not by itself establish any safety features in the application. Designers must ensure compliance with safety-related requirements and standards applicable to their applications. Designer may not use any TI products in life-critical medical equipment unless authorized officers of the parties have executed a special contract specifically governing such use. Life-critical medical equipment is medical equipment where failure of such equipment would cause serious bodily injury or death (e.g., life support, pacemakers, defibrillators, heart pumps, neurostimulators, and implantables). Such equipment includes, without limitation, all medical devices identified by the U.S. Food and Drug Administration as Class III devices and equivalent classifications outside the U.S.

TI may expressly designate certain products as completing a particular qualification (e.g., Q100, Military Grade, or Enhanced Product). Designers agree that it has the necessary expertise to select the product with the appropriate qualification designation for their applications and that proper product selection is at Designers' own risk. Designers are solely responsible for compliance with all legal and regulatory requirements in connection with such selection.

Designer will fully indemnify TI and its representatives against any damages, costs, losses, and/or liabilities arising out of Designer's non-compliance with the terms and provisions of this Notice.

Looking for pricing, stock, or lifecycle information?

Click below to explore more details on WIN SOURCE:

 [View SN75LVDS9637D on WIN SOURCE](#)

 [Texas Instruments](#) Information

Optimize Your Supply Chain with WIN SOURCE Solutions

-  Global Sourcing Solution
-  Obsolete Management
-  Cost Control Management
-  Shortage Management
-  Alternative Solution
-  Excess Inventory Management