



**THE DATASHEET OF  
DRV8801RTYT**



## DRV880x DMOS Full-Bridge Motor Drivers

### 1 Features

- H-Bridge Motor Driver
- Low  $R_{DS(on)}$  MOSFETs (0.4- $\Omega$  Typical)
- Low-Power Sleep Mode
- 100% PWM Supported
- 8-V to 36-V Operating Supply Voltage Range
- Thermally Enhanced Surface-Mount Package
- Protection Features:
  - VBB Undervoltage Lockout (UVLO)
  - Charge Pump Undervoltage (CPUV)
  - Overcurrent Protection (OCP)
  - Short-to-Supply Protection
  - Short-to-Ground Protection
  - Overtemperature Warning (OTW)
  - Overtemperature Shutdown (OTS)
  - Fault Condition Indication Pin (nFAULT)

### 2 Applications

- Printers
- Industrial Automation
- Robotics

### 3 Description

The DRV880x provides a versatile motor driver solution with a variety of capabilities. The device contains a full H-bridge which can be used to drive a brushed DC motor, one winding of a stepper motor, or other devices such as solenoids. A simple PHASE-ENABLE interface allows easy interfacing to controller circuits.

The output stages use N-channel power MOSFETs configured as an H-bridge. The DRV880x is capable of peak output currents up to  $\pm 2.8$  A and operating voltages up to 36 V. An internal charge pump generates the needed gate drive voltages.

A low-power sleep mode is provided which shuts down internal circuitry to achieve a very low quiescent current draw. This sleep mode can be set using a dedicated nSLEEP pin.

Internal protection functions are provided for undervoltage, charge pump fault, overcurrent, short-to-supply, short-to-ground, and overtemperature. Fault conditions are indicated through the nFAULT pin.

The DRV880x is packaged in a 16-pin WQFN package with PowerPAD™ (Eco-friendly: RoHS & no Sb/Br).

#### Device Information<sup>(1)</sup>

PART NUMBER	PACKAGE	BODY SIZE (NOM)
DRV8800	HTSSOP (16)	5.00 mm × 4.40 mm
	WQFN (16)	4.00 mm × 4.00 mm
DRV8801	HTSSOP (16)	5.00 mm × 4.40 mm
	WQFN (16)	4.00 mm × 4.00 mm

(1) For all available packages, see the orderable addendum at the end of the data sheet.

### 4 Simplified Schematic

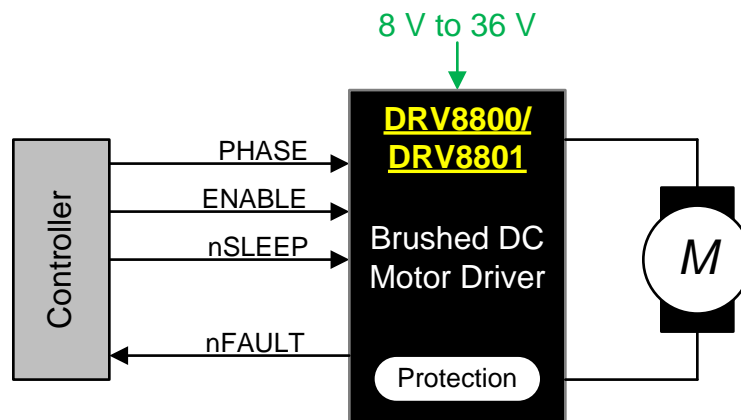

## Table of Contents

<b>1 Features</b> .....	<b>1</b>	9.3 Feature Description .....	<b>11</b>
<b>2 Applications</b> .....	<b>1</b>	9.4 Device Functional Modes .....	<b>13</b>
<b>3 Description</b> .....	<b>1</b>	<b>10 Application and Implementation</b> .....	<b>15</b>
<b>4 Simplified Schematic</b> .....	<b>1</b>	10.1 Application Information .....	<b>15</b>
<b>5 Revision History</b> .....	<b>2</b>	10.2 Typical Application .....	<b>15</b>
<b>6 Pin Configuration and Functions</b> .....	<b>3</b>	<b>11 Power Supply Recommendations</b> .....	<b>19</b>
<b>7 Specifications</b> .....	<b>5</b>	11.1 Bulk Capacitance .....	<b>19</b>
7.1 Absolute Maximum Ratings .....	<b>5</b>	<b>12 Layout</b> .....	<b>20</b>
7.2 ESD Ratings .....	<b>5</b>	12.1 Layout Guidelines .....	<b>20</b>
7.3 Recommended Operating Conditions .....	<b>5</b>	12.2 Layout Example .....	<b>20</b>
7.4 Thermal Information .....	<b>5</b>	<b>13 Device and Documentation Support</b> .....	<b>22</b>
7.5 Electrical Characteristics .....	<b>6</b>	13.1 Related Links .....	<b>22</b>
7.6 Typical Characteristics .....	<b>7</b>	13.2 Trademarks .....	<b>22</b>
<b>8 Parameter Measurement Information</b> .....	<b>8</b>	13.3 Electrostatic Discharge Caution .....	<b>22</b>
<b>9 Detailed Description</b> .....	<b>10</b>	13.4 Glossary .....	<b>22</b>
9.1 Overview .....	<b>10</b>	<b>14 Mechanical, Packaging, and Orderable Information</b> .....	<b>22</b>
9.2 Functional Block Diagrams .....	<b>10</b>		

## 5 Revision History

<b>Changes from Revision I (January 2014) to Revision J</b>	<b>Page</b>
<ul style="list-style-type: none"> <li>Added <i>ESD Ratings</i> table, <i>Feature Description</i> section, <i>Device Functional Modes</i>, <i>Application and Implementation</i> section, <i>Power Supply Recommendations</i> section, <i>Layout</i> section, <i>Device and Documentation Support</i> section, and <i>Mechanical, Packaging, and Orderable Information</i> section .....</li> </ul>	<b>5</b>
<hr/>	
<b>Changes from Revision H (November 2013) to Revision I</b>	<b>Page</b>
<ul style="list-style-type: none"> <li>Added <math>I_{OCP}</math> to ELECTRICAL CHARACTERISTICS .....</li> <li>Changed <a href="#">Figure 5</a> .....</li> </ul>	<b>6</b> <b>9</b>
<hr/>	
<b>Changes from Revision G (October 2013) to Revision H</b>	<b>Page</b>
<ul style="list-style-type: none"> <li>Changed maximum junction temperature from 190°C to 150°C .....</li> <li>Changed VTRP description/test conditions .....</li> <li>Changed Protection Circuitry section .....</li> <li>Changed Note in SENSE section .....</li> </ul>	<b>5</b> <b>6</b> <b>6</b> <b>13</b>

## 6 Pin Configuration and Functions

**DRV8800 RTY Package  
16-Pin WQFN  
Top View**

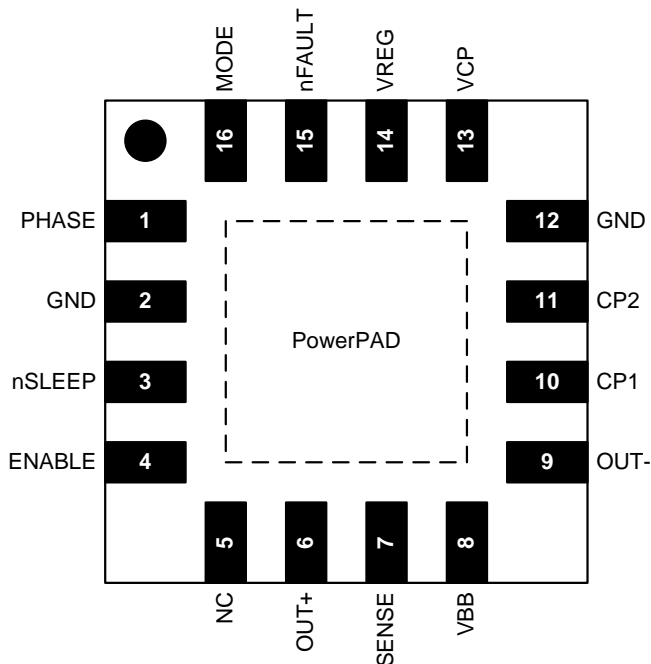

**DRV8801 RTY Package  
16-Pin WQFN  
Top View**

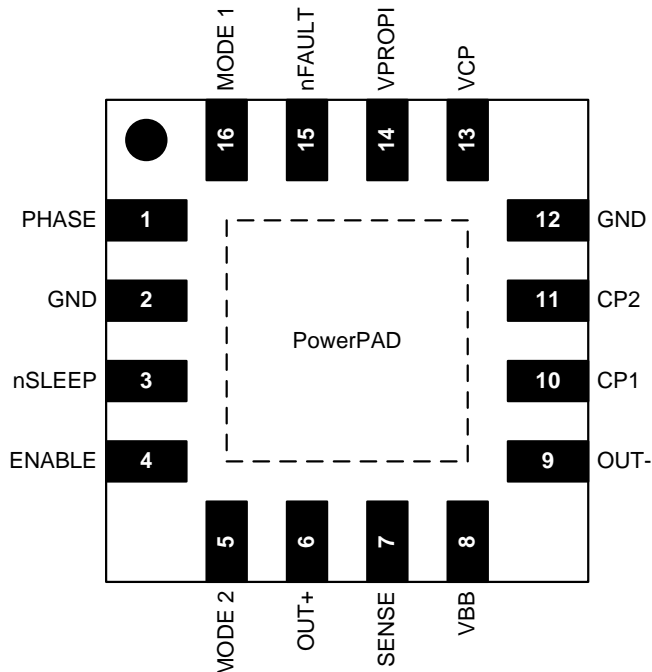

**DRV8800 PWP Package  
16-Pin HTSSOP  
Top View**

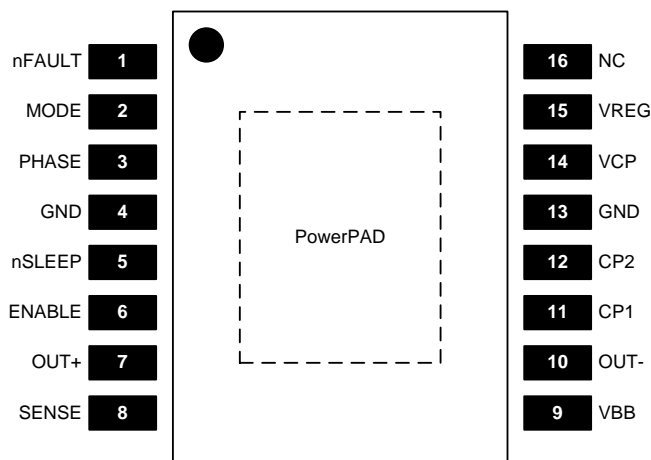

**DRV8801 PWP Package  
16-Pin HTSSOP  
Top View**

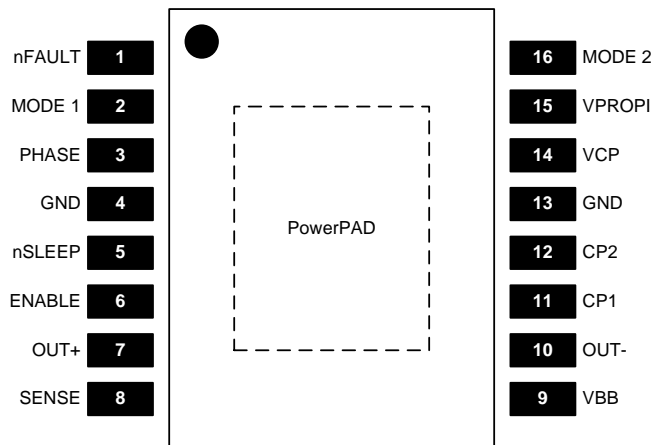

**Pin Functions**

NAME	PIN				I/O	DESCRIPTION
	DRV8800		DRV8801			
	WQFN	HTSSOP	WQFN	HTSSOP		
CP1	10	11	10	11	P	Charge pump switching node. Connect a 0.1- $\mu$ F X7R ceramic capacitor rated for VBB between CP1 and CP2.
CP2	11	12	11	12	P	Charge pump switching node. Connect a 0.1- $\mu$ F X7R ceramic capacitor rated for VBB between CP1 and CP2.
ENABLE	4	6	4	6	I	Enable logic input. Set high to enable the H-bridge.
GND	2	4	2	4	P	Device ground
MODE	16	2	—	—	I	Mode logic input
MODE 1	—	—	16	2	I	Mode logic input
MODE 2	—	—	5	16	I	Mode 2 logic input
NC	5	16	—	—	NC	No connect
nFAULT	15	1	15	1	OD	Pulled logic low in FAULT condition. Open-drain output requires external pullup.
nSLEEP	3	5	3	5	I	Sleep logic input. Set low to enter low-power sleep mode.
OUT+	6	7	6	7	O	DMOS H-bridge output. Connect to motor terminal.
OUT-	9	10	9	10	O	DMOS H-bridge output. Connect to motor terminal.
PHASE	1	3	1	3	I	WQFN Package: Phase logic input for direction control. HTSSOP Package: Phase logic input. Controls the direction of the H-bridge.
VBB	8	9	8	9	P	Connect to motor power supply. Bypass to ground with 0.1- $\mu$ F ceramic capacitor and appropriate bulk capacitance rated for VBB.
VCP	13	14	13	14	P	Charge pump output. Connect a 0.1- $\mu$ F 16-V ceramic capacitor between VCP and VBB.
VREG	14	15	—	—	P	Regulated voltage.
VPROPI	—	—	14	15	O	Voltage output proportional to winding current.
PowerPAD	—	—	—	—	—	Exposed pad for thermal dissipation. Connect to ground.

## 7 Specifications

### 7.1 Absolute Maximum Ratings

over operating free-air temperature range (unless otherwise noted)<sup>(1)</sup>

		MIN	MAX	UNIT
VBB	Load supply voltage <sup>(2)</sup>	-0.3	40	V
	Output current	-2.8	2.8	A
V <sub>Sense</sub>	Sense voltage	-500	500	mV
	VBB to OUTx		36	V
	OUTx to SENSE		36	V
VDD	Logic input voltage <sup>(2)</sup>	-0.3	7	V
	Continuous total power dissipation	See <a href="#">Thermal Information</a>		
T <sub>A</sub>	Operating free-air temperature	-40	85	°C
T <sub>J</sub>	Maximum junction temperature		150	°C
T <sub>stg</sub>	Storage temperature	-40	125	°C

- (1) Stresses beyond those listed under *Absolute Maximum Ratings* may cause permanent damage to the device. These are stress ratings only, and functional operation of the device at these or any other conditions beyond those indicated under *Recommended Operating Conditions* is not implied. Exposure to absolute-maximum-rated conditions for extended periods may affect device reliability.
- (2) All voltage values are with respect to network ground terminal.

### 7.2 ESD Ratings

		VALUE	UNIT
V <sub>(ESD)</sub>	Electrostatic discharge	Human body model (HBM), per ANSI/ESDA/JEDEC JS-001, all pins <sup>(1)</sup>	±2000
		Charged device model (CDM), per JEDEC specification JESD22-C101, all pins <sup>(2)</sup>	±500
			V

- (1) JEDEC document JEP155 states that 500-V HBM allows safe manufacturing with a standard ESD control process.
- (2) JEDEC document JEP157 states that 250-V CDM allows safe manufacturing with a standard ESD control process.

### 7.3 Recommended Operating Conditions

		MIN	NOM	MAX	UNIT
V <sub>IN</sub>	Input voltage, VBB	8	32	38	V
T <sub>A</sub>	Operating free-air temperature	-40		85	°C

### 7.4 Thermal Information

THERMAL METRIC <sup>(1)</sup>	DRV880x		UNIT	
	RTY (WQFN)	PWP (HTSSOP)		
	16 PINS	16 PINS		
R <sub>θJA</sub>	Junction-to-ambient thermal resistance	38.1	43.9	°C/W
R <sub>θJC(top)</sub>	Junction-to-case (top) thermal resistance	36.7	30.8	
R <sub>θJB</sub>	Junction-to-board thermal resistance	16.1	25.3	
ψ <sub>JT</sub>	Junction-to-top characterization parameter	0.3	1.1	
ψ <sub>JB</sub>	Junction-to-board characterization parameter	16.2	25	
R <sub>θJC(bot)</sub>	Junction-to-case (bottom) thermal resistance	4.1	5.6	

- (1) For more information about traditional and new thermal metrics, see the *IC Package Thermal Metrics* application report, [SPRA953](#).

## 7.5 Electrical Characteristics

over recommended operating conditions (unless otherwise noted)

PARAMETER		TEST CONDITIONS	MIN	TYP	MAX	UNIT
IBB	Motor supply current	$f_{PWM} < 50 \text{ kHz}$		6		mA
		Charge pump on, Outputs disabled		3.2		
		Sleep mode				10
$V_{IH}$	PHASE, ENABLE, MODE input voltage		2			V
$V_{IL}$				0.8		
$V_{IH}$	nSLEEP input voltage		2.7			V
$V_{IL}$				0.8		
$I_{IH}$	PHASE, MODE input current	$V_{IN} = 2 \text{ V}$		<1.0	20	$\mu\text{A}$
$I_{IL}$		$V_{IN} = 0.8 \text{ V}$	-20	$\leq -2.0$	20	
$I_{IH}$	ENABLE input current	$V_{IN} = 2 \text{ V}$		40	100	$\mu\text{A}$
$I_{IL}$		$V_{IN} = 0.8 \text{ V}$		16	40	
$I_{IH}$	nSLEEP input current	$V_{IN} = 2.7 \text{ V}$		27	50	$\mu\text{A}$
$I_{IL}$		$V_{IN} = 0.8 \text{ V}$		<1	10	
$V_{OL}$	nFAULT output voltage	$I_{sink} = 1 \text{ mA}$			0.4	V
VBBNFR	VBB nFAULT release	$8 \text{ V} < V_{BB} < 40 \text{ V}$		12	13.8	V
$V_{IHys}$	Input hysteresis, except nSLEEP		100	500	800	mV
$r_{DS(on)}$	Output ON-resistance	Source driver, $I_{OUT} = -2.8 \text{ A}$ , $T_J = 25^\circ\text{C}$		0.48		$\Omega$
		Source driver, $I_{OUT} = -2.8 \text{ A}$ , $T_J = 125^\circ\text{C}$		0.74	0.85	
		Sink driver, $I_{OUT} = 2.8 \text{ A}$ , $T_J = 25^\circ\text{C}$		0.35		
		Sink driver, $I_{OUT} = 2.8 \text{ A}$ , $T_J = 125^\circ\text{C}$		0.52	0.7	
VTRP	RSENSE voltage trip	SENSE connected to ground through a 0.2- $\Omega$ resistor		500		mV
$V_f$	Body diode forward voltage	Source diode, $I_f = -2.8 \text{ A}$			1.4	V
		Sink diode, $I_f = 2.8 \text{ A}$			1.4	
$t_{pd}$	Propagation delay time	PWM, Change to source or sink ON		600		ns
		PWM, Change to source or sink OFF		100		
$t_{COD}$	Crossover delay			500		ns
DAGain	Differential AMP gain	Sense = 0.1 V to 0.4 V		5		V/V
<b>PROTECTION CIRCUITRY</b>						
VUV	UVLO threshold	VBB increasing		6.5	7.5	V
$I_{OCP}$	Overcurrent threshold		3			A
$t_{DEG}$	Overcurrent deglitch time			3		$\mu\text{s}$
$t_{OCP}$	Overcurrent retry time			1.2		ms
TJW	Thermal warning temperature	Temperature increasing <sup>(1)</sup>		160		$^\circ\text{C}$
TJTSD	Thermal shutdown temperature	Temperature increasing <sup>(2)</sup>		175		$^\circ\text{C}$

- (1) After the device reaches the thermal warning temperature of 160°C, the device will remain in thermal warning until the device cools to 145°C. This is known as the device's thermal warning hysteresis.
- (2) After the device reaches the thermal shutdown temperature of 175°C, the device will remain in thermal shutdown until the device cools to 160°C. This is known as the device's thermal shutdown hysteresis.

## 7.6 Typical Characteristics

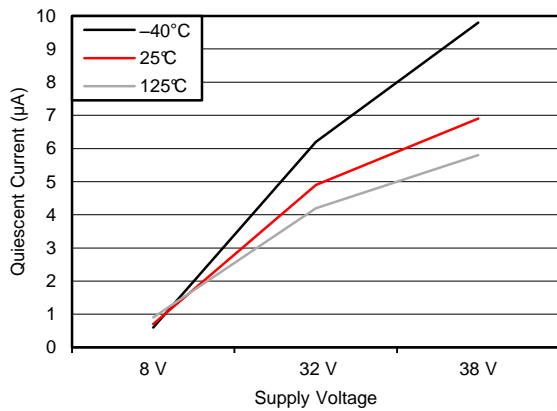

Figure 1.  $I_{VBBQ}$  vs  $V_{BB}$

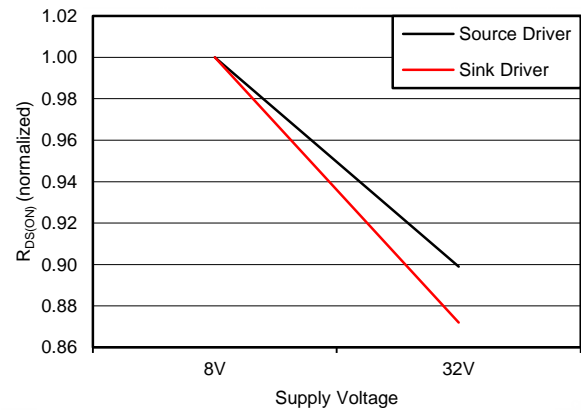

Figure 2.  $R_{DS(ON)}$  vs  $V_{BB}$  (Normalized to  $V_{BB} = 8\text{ V}$ )

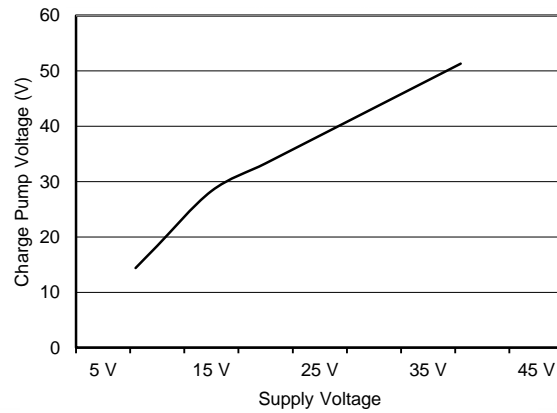

Figure 3.  $V_{CP}$  vs  $V_{BB}$

## 8 Parameter Measurement Information

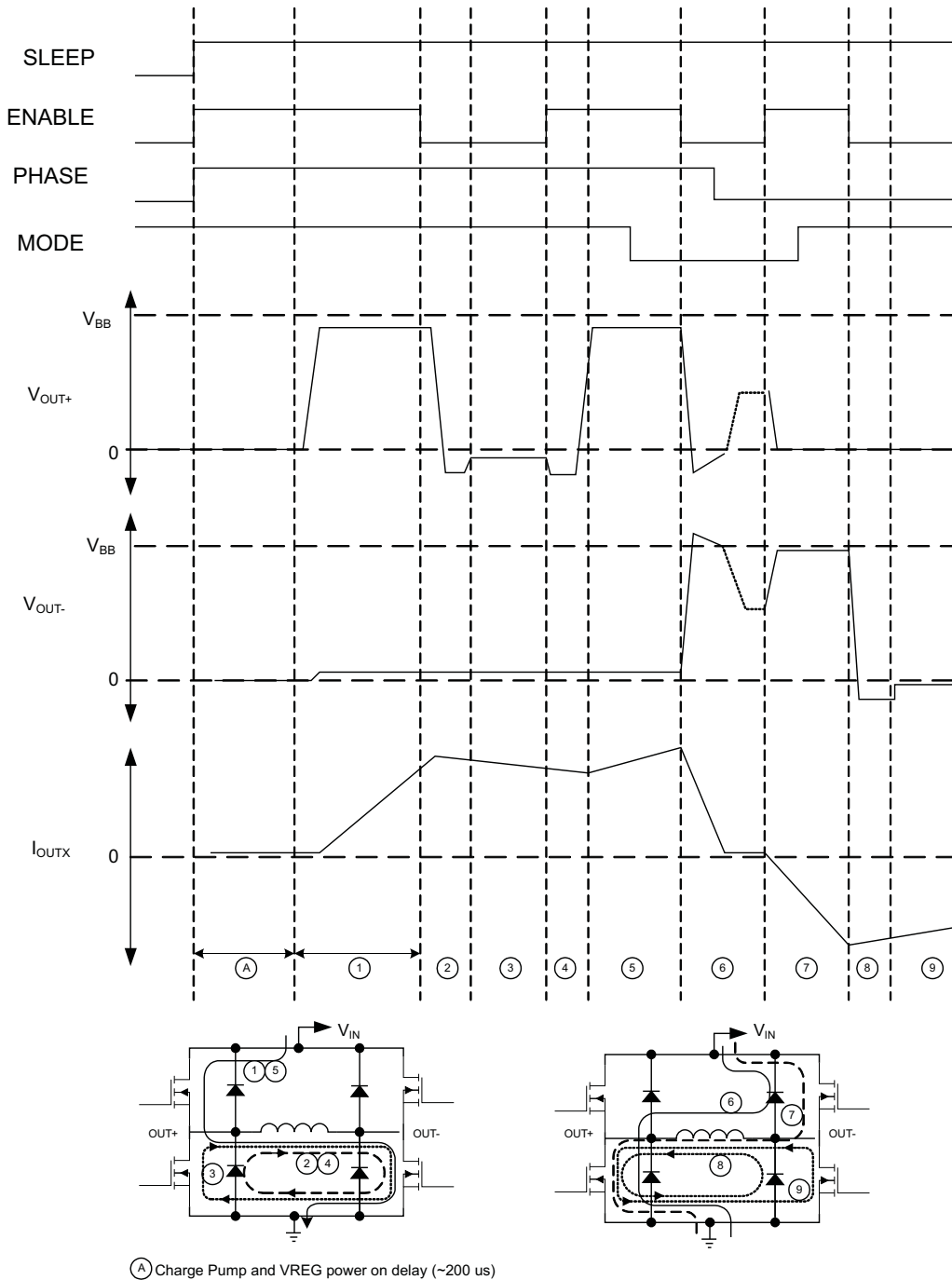

Figure 4. PWM Control Timing

Parameter Measurement Information (continued)

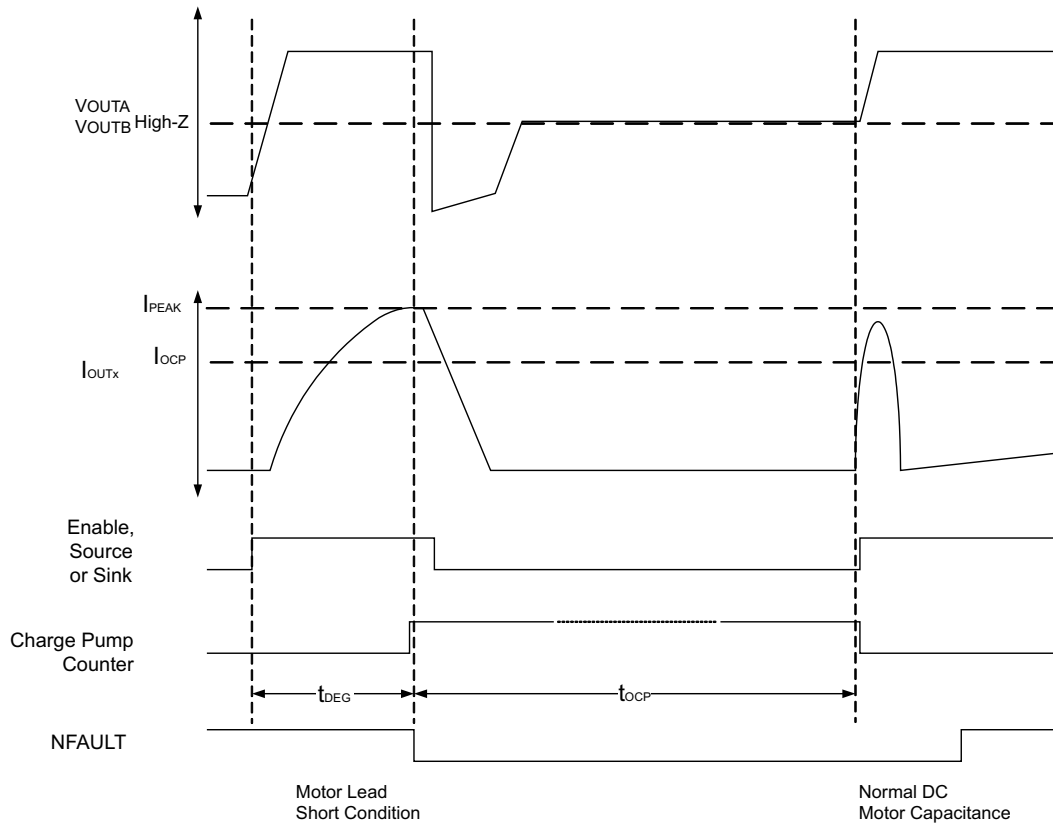

Figure 5. Overcurrent Control Timing

## 9 Detailed Description

### 9.1 Overview

The DRV880x devices are integrated motor driver solutions for brushed DC motors. The devices integrate a DMOS H-bridge, protection circuitry, and simple digital interface. The devices can be powered with a supply voltage between 8 and 36 V and are capable of providing an output current up to 2.8 A.

A PHASE-ENABLE interface allows for easy interfacing to the controller circuit. The PHASE input controls the direction of the H-bridge and the ENABLE input specifies whether the H-bridge is enabled or not.

Two MODE pins allow for specifying which current decay method the device utilizes. MODE1 specifies between fast decay or slow decay and MODE2 specifies between high side or low side slow decay.

The DRV8801 provides the option to monitor the motor winding current through a proportional voltage output.

### 9.2 Functional Block Diagrams

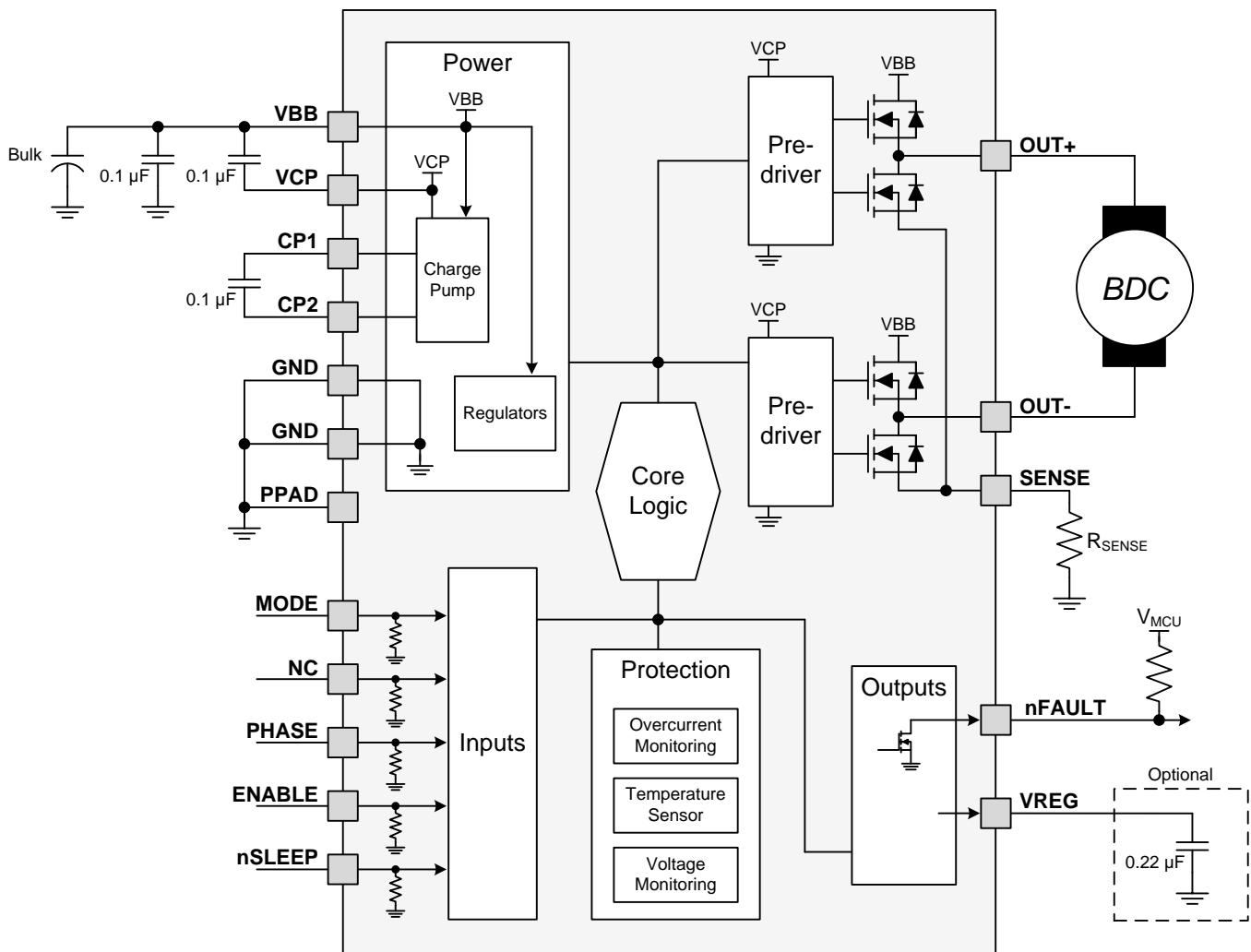

Figure 6. DRV8800 Functional Block Diagram

Functional Block Diagrams (continued)

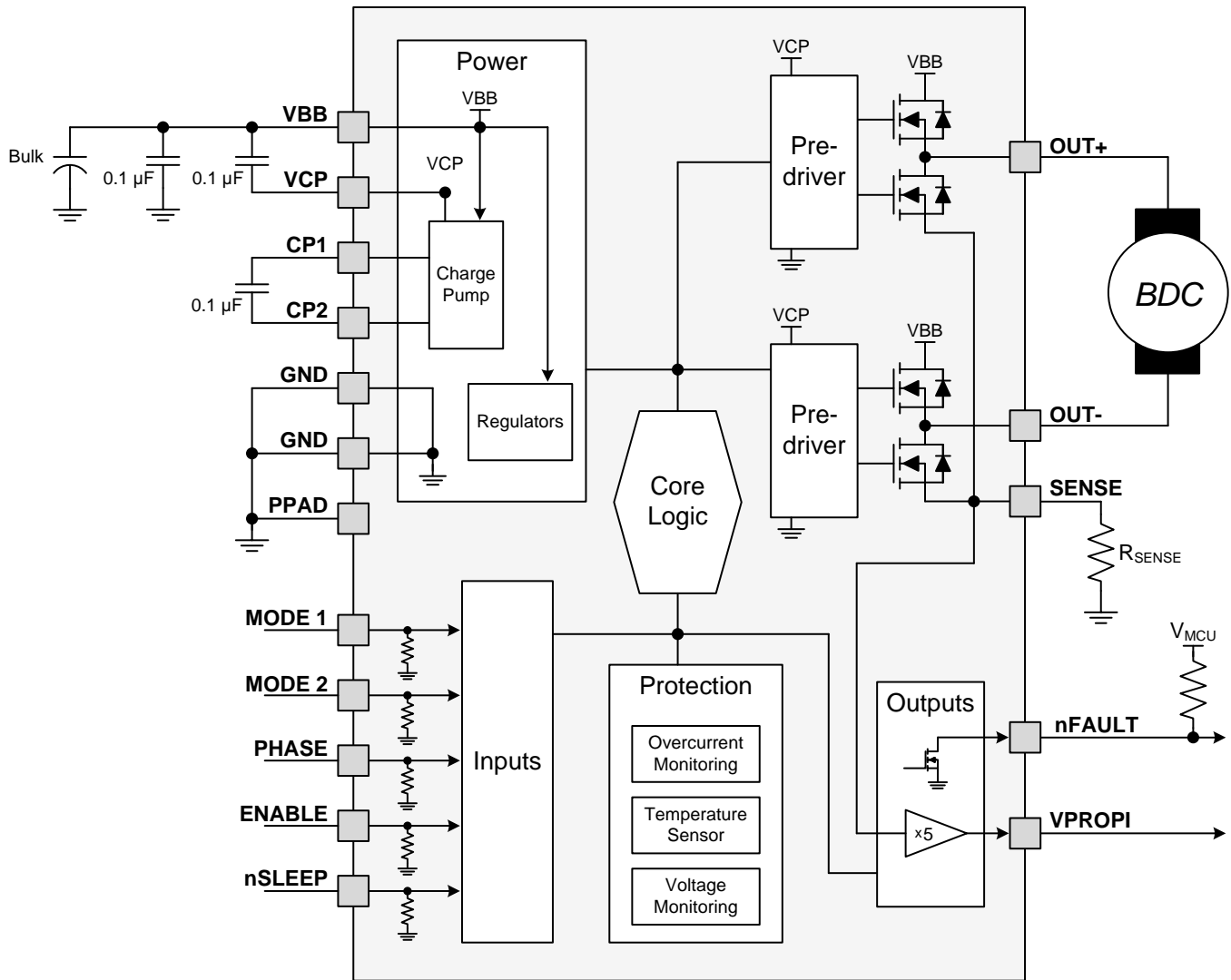

Figure 7. DRV8801 Functional Block Diagram

9.3 Feature Description

9.3.1 Logic Inputs

TI recommends using a high-value pullup resistor when logic inputs are pulled up to  $V_{DD}$ . This resistor limits the current to the input in case an overvoltage event occurs. Logic inputs are nSLEEP, MODE, PHASE, and ENABLE. Voltages higher than 7 V on any logic input can cause damage to the input structure.

9.3.2 VREG (DRV8800 Only)

This output represents a measurement of the internal regulator voltage. This pin should be left disconnected. A voltage of approximately 7.5 V can be measured at this pin.

## Feature Description (continued)

### 9.3.3 VPROPI (DRV8801 Only)

This output offers an analog voltage proportional to the winding current. Voltage at this terminal is five times greater than the motor winding current ( $V_{PROPI} = 5 \times I$ ). VPROPI is meaningful only if there is a resistor connected to the SENSE pin. If SENSE is connected to ground, VPROPI measures 0 V. During slow decay, VPROPI outputs 0 V. VPROPI can output a maximum of 2.5 V, since at 500 mV on SENSE, the H-bridge is disabled.

### 9.3.4 Charge Pump

The charge pump is used to generate a supply above VBB to drive the source-side DMOS gates. A 0.1- $\mu$ F ceramic monolithic capacitor should be connected between CP1 and CP2 for pumping purposes. A 0.1- $\mu$ F ceramic monolithic capacitor, CStorage, should be connected between VCP and VBB to act as a reservoir to run the high-side DMOS devices. The VCP voltage level is internally monitored and, in the case of a fault condition, the outputs of the device are disabled.

### 9.3.5 Shutdown

As a measure to protect the device, faults caused by very high junction temperatures or low voltage on VCP disable the outputs of the device until the fault condition is removed. At power on, the UVLO circuit disables the drivers.

### 9.3.6 Low-Power Mode

Control input nSLEEP is used to minimize power consumption when the DRV880x is not in use. This disables much of the internal circuitry, including the internal voltage rails and charge pump. nSLEEP is asserted low. A logic high on this input pin results in normal operation. When switching from low to high, the user should allow a 1-ms delay before applying PWM signals. This time is needed for the charge pump to stabilize.

- **MODE 1 (MODE on the DRV8800)**  
Input MODE 1 is used to toggle between fast-decay mode and slow-decay mode. A logic high puts the device in slow-decay mode.
- **MODE 2 (DRV8801 only)**  
MODE 2 is used to select which set of drivers (high side versus low side) is used during the slow-decay recirculation. MODE 2 is meaningful only when MODE 1 is asserted high. A logic high on MODE 2 has current recirculation through the high-side drivers. A logic low has current recirculation through the low-side drivers.

### 9.3.7 Braking

The braking function is implemented by driving the device in slow-decay mode (MODE 1 pin is high) and deasserting the enable to low. Because it is possible to drive current in both directions through the DMOS switches, this configuration effectively shorts out the motor-generated BEMF as long as the ENABLE chop mode is asserted. The maximum current can be approximated by  $V_{BEMF}/R_L$ . Care should be taken to ensure that the maximum ratings of the device are not exceeded in worse-case braking situations – high-speed and high-inertia loads.

### 9.3.8 Diagnostic Output

The nFAULT pin signals a problem with the chip via an open-drain output. A motor fault, undervoltage condition, or  $T_J > 160^\circ\text{C}$  drives the pin low. This output is not valid when nSLEEP puts the device into minimum power dissipation mode (that is, nSLEEP is low). nFAULT stays asserted ( $nFAULT = L$ ) until VBB reaches VBBNFR to give the charge pump headroom to reach its undervoltage threshold. nFAULT is a status-only signal and does not affect any device functionality. The H-bridge portion still operates normally down to  $V_{BB} = 8\text{ V}$  with nFAULT asserted.

## Feature Description (continued)

### 9.3.9 Thermal Shutdown (TSD)

Two die-temperature monitors are integrated on the chip. As die temperature increases toward the maximum, a thermal warning signal is triggered at 160°C. This fault drives the nFAULT low, but does not disable the operation of the chip. If the die temperature increases further, to approximately 175°C, the full-bridge outputs are disabled until the internal temperature falls below a hysteresis of 15°C.

**Table 1. Control Logic Table<sup>(1)</sup>**

PINS							OPERATION
PHASE	ENABLE	MODE 1	MODE 2	nSLEEP	OUT+	OUT-	
1	1	X	X	1	H	L	Forward
0	1	X	X	1	L	H	Reverse
X	0	1	0	1	L	L	Brake (slow decay)
X	0	1	1	1	H	H	Brake (slow decay)
1	0	0	X	1	L	H	Fast-decay synchronous rectification <sup>(2)</sup>
0	0	0	X	1	H	L	Fast-decay synchronous rectification <sup>(2)</sup>
X	X	X	X	0	Z	Z	Sleep mode

(1) X = Don't care, Z = high impedance

(2) To prevent reversal of current during fast-decay synchronous rectification, outputs go to the high-impedance state as the current approaches 0 A.

### 9.3.10 Overcurrent Protection

The current flowing through the high-side and low-side drivers is monitored to ensure that the motor lead is not shorted to supply or ground. If a short is detected, the full-bridge outputs are turned off, flag nFAULT is driven low, and a 1.2-ms fault timer is started. After this 1.2-ms period,  $t_{OCP}$ , the device is then allowed to follow the input commands and another turnon is attempted (nFAULT becomes high again during this attempt). If there is still a fault condition, the cycle repeats. If after  $t_{OCP}$  expires it is determined the short condition is not present, normal operation resumes and nFAULT is deasserted.

### 9.3.11 SENSE

A low-value resistor can be placed between the SENSE pin and ground for current-sensing purposes. To minimize ground-trace IR drops in sensing the output current level, the current-sensing resistor should have an independent ground return to the star ground point. This trace should be as short as possible. For low-value sense resistors, the IR drops in the PCB can be significant, and should be taken into account.

$$P_D = I^2 (2 \cdot r_{DS(on)Sink}) \quad (1)$$

#### NOTE

When selecting a value for the sense resistor, SENSE does not exceed the maximum voltage of  $\pm 500$  mV. The H-bridge is disabled and enters recirculation when any current in the motor windings generates a SENSE voltage greater than or equal to 500 mV.

## 9.4 Device Functional Modes

### 9.4.1 Device Operation

The DRV880x supports a low power sleep mode through the nSLEEP pin. In this mode the device shuts down a majority of the internal circuitry including the internal voltage rails and charge pump. Bringing the nSLEEP pin HIGH will put the device back into its active state.

During normal operation the DRV880x is designed to operate a single brushed DC motor. The outputs are connected to each side on the motor coil, allowing for full bidirectional control.

**Device Functional Modes (continued)**

**9.4.1.1 Slow-Decay SR (Brake Mode)**

In slow-decay mode, both low-side sinking drivers turn on, allowing the current to circulate through the H-bridge's low side (two sink drivers) and the load. Power dissipation  $I^2R$  losses in the two sink DMOS drivers:

**9.4.1.2 Fast Decay With Synchronous Rectification**

This decay mode is equivalent to a phase change where the opposite drivers are switched on. When in fast decay, the motor current is not allowed to go negative (direction change). Instead, as the current approaches zero, the drivers turn off. The power calculation is the same as the drive current calculation (see Equation 5).

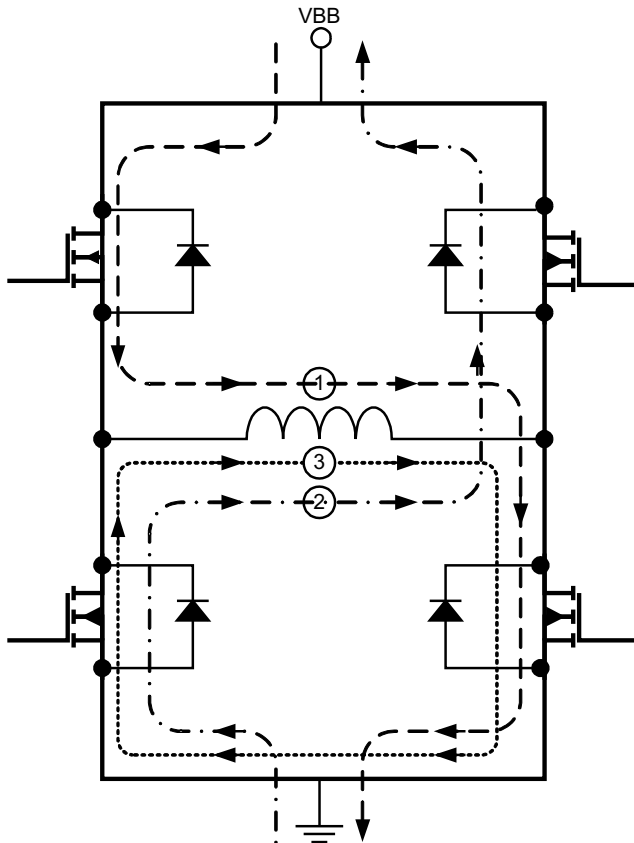

- ① Drive Current
- ② Fast decay with synchronous rectification (reverse)
- ③ Slow decay with synchronous rectification (brake)

**Figure 8. Current Path DRV8800**

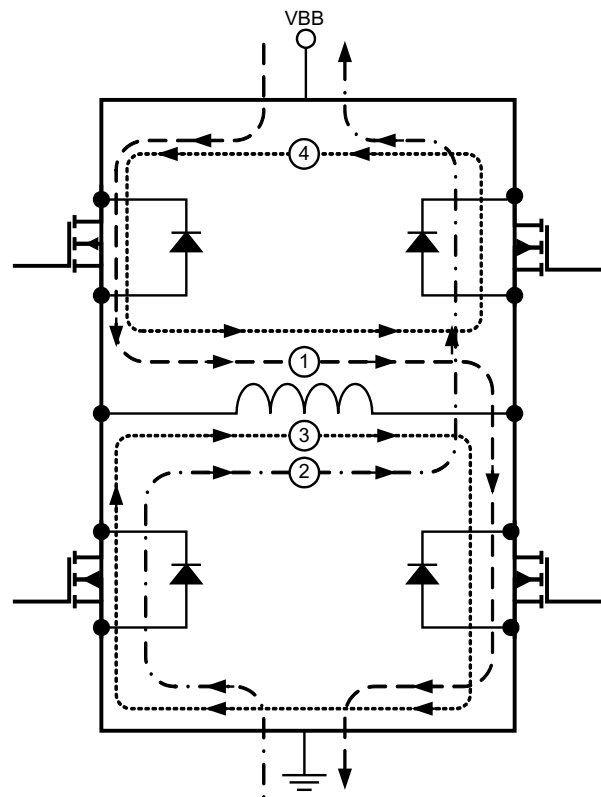

- ① Drive Current
- ② Fast decay with synchronous rectification (reverse)
- ③ Slow decay with synchronous rectification (brake) Low Side
- ④ Slow decay with synchronous rectification (brake) High Side

**Figure 9. Current Path DRV8801**

## 10 Application and Implementation

### NOTE

Information in the following applications sections is not part of the TI component specification, and TI does not warrant its accuracy or completeness. TI's customers are responsible for determining suitability of components for their purposes. Customers should validate and test their design implementation to confirm system functionality.

### 10.1 Application Information

DRV880x device is used in medium voltage brushed DC motor control applications.

### 10.2 Typical Application

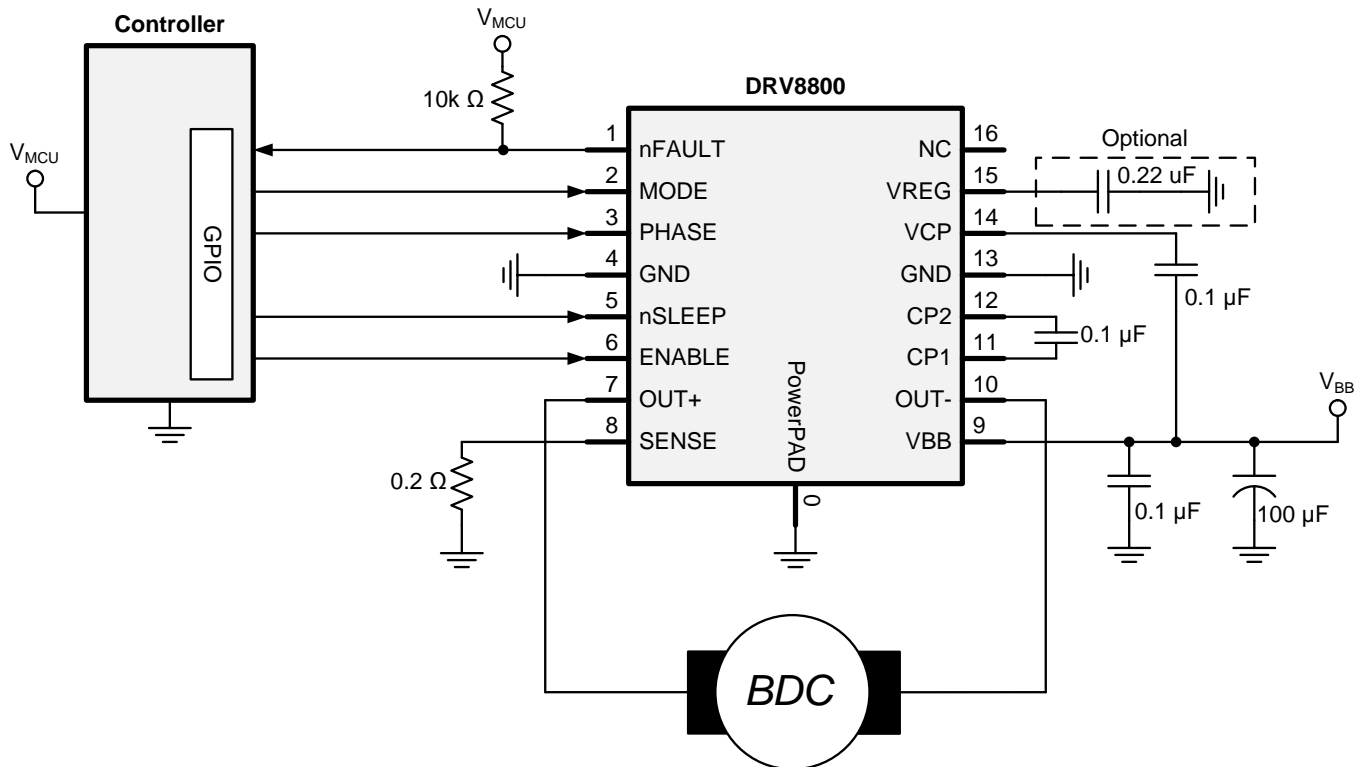

**Figure 10. DRV8800 Typical Application Schematic**

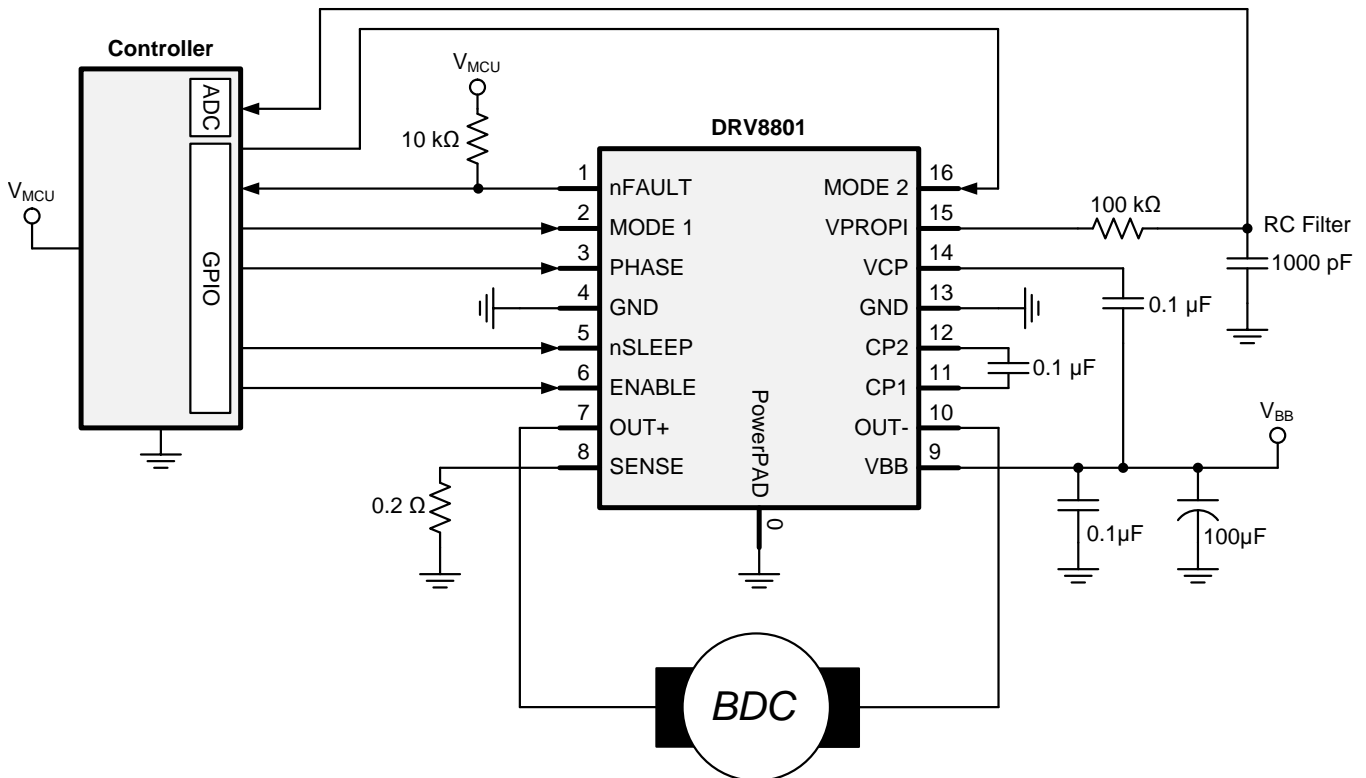
**Typical Application (continued)**

**Figure 11. DRV8801 Typical Application Schematic**
**10.2.1 Design Requirements**

For this design example, use the parameters listed in [Table 2](#) as the input parameters.

**Table 2. Design Parameters**

DESIGN PARAMETER	REFERENCE	EXAMPLE VALUE
Motor Voltage	VBB	24 V
Motor RMS Current	IRMS	0.8 A
Motor Startup Current	ISTART	2 A
Motor Current Trip Point	ITRIP	2.5 A

**10.2.2 Detailed Design Procedure**
**10.2.2.1 Motor Voltage**

The motor voltage to use will depend on the ratings of the motor selected and the desired RPM. A higher voltage spins a brushed DC motor faster with the same PWM duty cycle applied to the power FETs. A higher voltage also increases the rate of current change through the inductive motor windings.

**10.2.2.2 Power Dissipation**

The power dissipation of the DRV880x is a function of the RMS motor current and the each output's FET resistance ( $R_{DS(ON)}$ ).

$$\text{Power} \approx I_{RMS}^2 \times (\text{High-Side } R_{DS(ON)} + \text{Low-Side } R_{DS(ON)}) \quad (2)$$

For this example, the ambient temperature is 35°C, and the junction temperature reaches 65°C. At 65°C, the sum of  $R_{DS(ON)}$  is about 1Ω. With an example motor current of 0.8A, the dissipated power in the form of heat will be  $0.8 A^2 \times 1 \Omega = 0.64 W$ .

The temperature that the DRV880x reaches will depend on the thermal resistance to the air and PCB. It is important to solder the device PowerPAD to the PCB ground plane, with vias to the top and bottom board layers, to dissipate heat into the PCB and reduce the device temperature. In the example used here, the DRV880x had an effective thermal resistance  $R_{\theta JA}$  of 47°C/W, and:

$$T_J = T_A + (P_D \times R_{\theta JA}) = 35^\circ\text{C} + (0.64 W \times 47^\circ\text{C/W}) = 65^\circ\text{C} \quad (3)$$

### 10.2.2.3 Motor Current Trip Point

When the voltage on pin SENSE exceeds  $V_{TRIP}$  (0.5 V), overcurrent is detected. The  $R_{SENSE}$  resistor should be sized to set the desired  $I_{TRIP}$  level.

$$R_{SENSE} = 0.5 V / I_{TRIP} \quad (4)$$

To set  $I_{TRIP}$  to 2.5 A,  $R_{SENSE} = 0.5 V / 2.5 A = 0.2 \Omega$ .

To prevent false trips,  $I_{TRIP}$  must be higher than regular operating current. Motor current during startup is typically much higher than steady-state spinning, because the initial load torque is higher, and the absence of back-EMF causes a higher voltage and extra current across the motor windings.

It can be beneficial to limit startup current by using series inductors on the DRV880x output, as that allows  $I_{TRIP}$  to be lower, and it may decrease the system's required bulk capacitance. Startup current can also be limited by ramping the forward drive duty cycle.

### 10.2.2.4 Sense Resistor Selection

For optimal performance, it is important for the sense resistor to be:

- Surface-mount
- Low inductance
- Rated for high enough power
- Placed closely to the motor driver

### 10.2.2.5 Drive Current

This current path is through the high-side sourcing DMOS driver, motor winding, and low-side sinking DMOS driver. Power dissipation  $I^2R$  losses in one source and one sink DMOS driver, as shown in [Equation 5](#).

$$P_D = I^2 (r_{DS(on)Source} + r_{DS(on)Sink}) \quad (5)$$

### 10.2.3 Application Curves

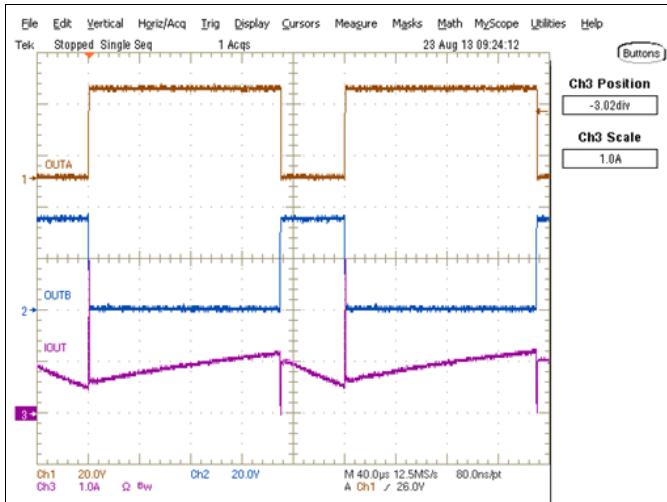

**Figure 12. Forward Drive, Fast Decay**

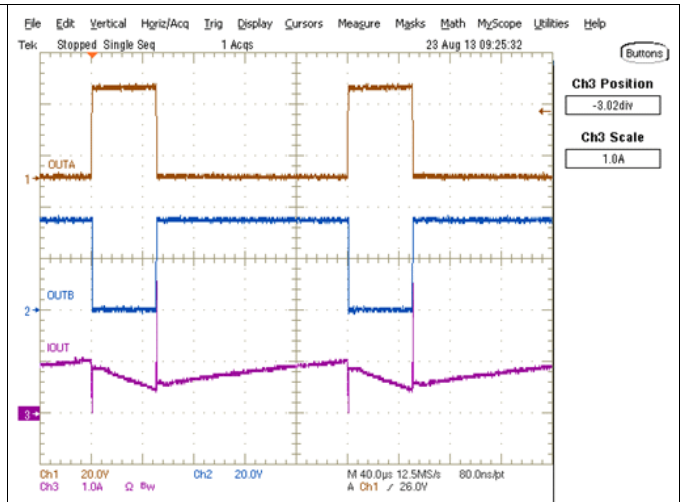

**Figure 13. Reverse Drive, Fast Decay**

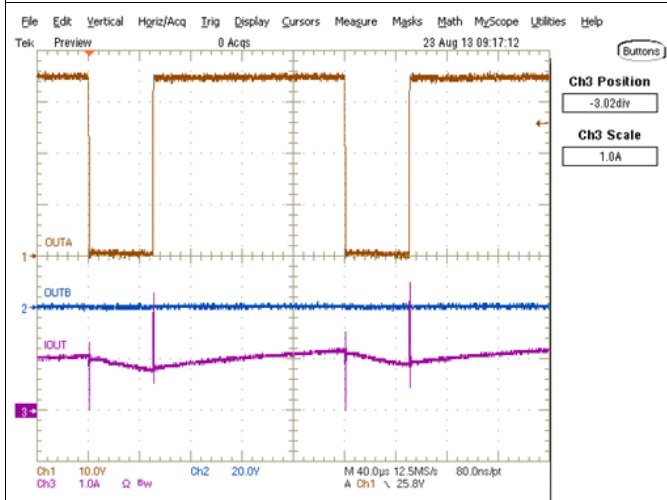

**Figure 14. Forward Drive, Slow Decay**

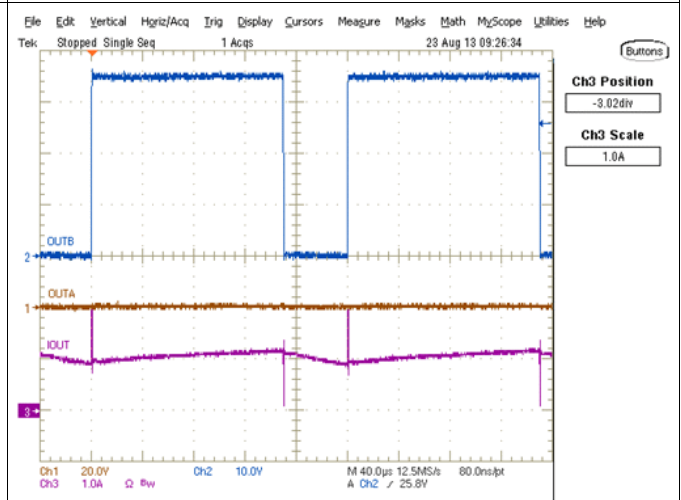

**Figure 15. Reverse Drive, Slow Decay**

## 11 Power Supply Recommendations

### 11.1 Bulk Capacitance

Having appropriate local bulk capacitance is an important factor in motor drive system design. It is generally beneficial to have more bulk capacitance, while the disadvantages are increased cost and physical size.

The amount of local capacitance needed depends on a variety of factors, including:

- The highest current required by the motor system.
- The capacitance of the power supply and its ability to source current.
- The amount of parasitic inductance between the power supply and motor systems.
- The acceptable voltage ripple.
- The type of motor used (Brushed DC, Brushless DC, Stepper).
- The motor braking method.

The inductance between the power supply and motor drive system will limit the rate current can change from the power supply. If the local bulk capacitance is too small, the system will respond to excessive current demands or dumps from the motor with a change in voltage. When adequate bulk capacitance is used, the motor voltage remains stable and high current can be quickly supplied.

The data sheet generally provides a recommended value, but system-level testing is required to determine the appropriate sized bulk capacitor.

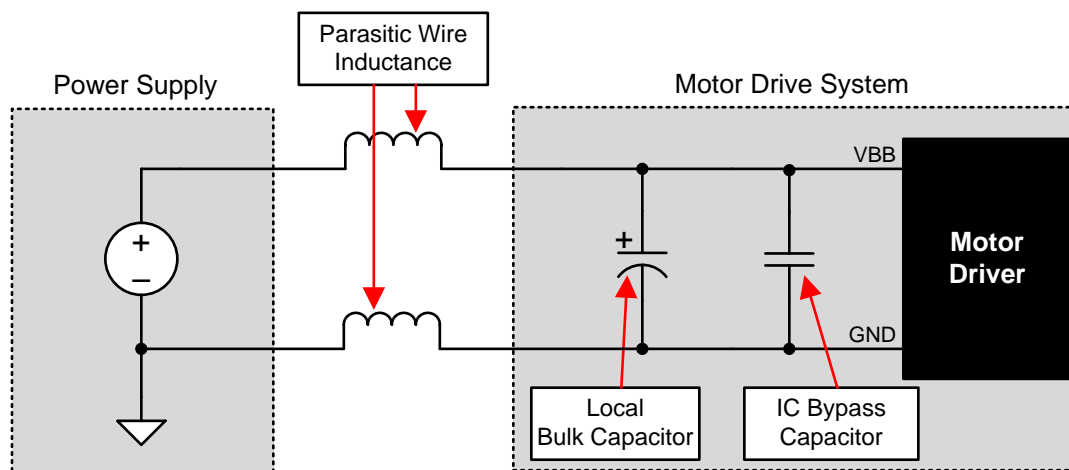

Figure 16. Example Setup of Motor Drive System With External Power Supply

## 12 Layout

### 12.1 Layout Guidelines

- The printed-circuit-board (PCB) should use a heavy ground plane. For optimal electrical and thermal performance, the DRV880x must be soldered directly onto the board. On the underside of the DRV880x is a thermal pad, which provides a path for enhanced thermal dissipation. The thermal pad should be soldered directly to an exposed surface on the PCB. Thermal vias are used to transfer heat to other layers of the PCB.
- The load supply pin VBB, should be decoupled with an electrolytic capacitor (typically 100  $\mu\text{F}$ ) in parallel with a ceramic capacitor (0.1  $\mu\text{F}$ ) placed as close as possible to the device.
- The ceramic capacitors (0.1  $\mu\text{F}$ ) between VCP and VBB and between CP1 and CP2 should be placed as close as possible to the device.
- The SENSE resistor should be close as possible to the SENSE pin and ground return to minimize parasitic inductance.

### 12.2 Layout Example

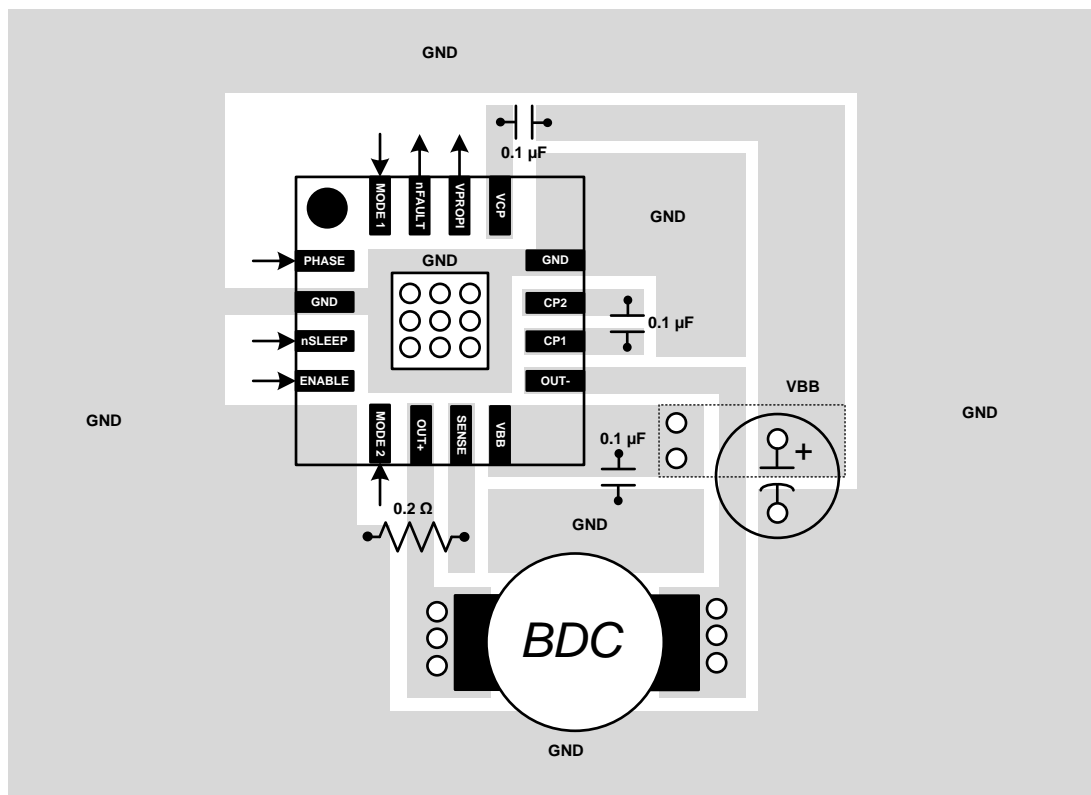

Figure 17. RTY Layout Example

Layout Example (continued)

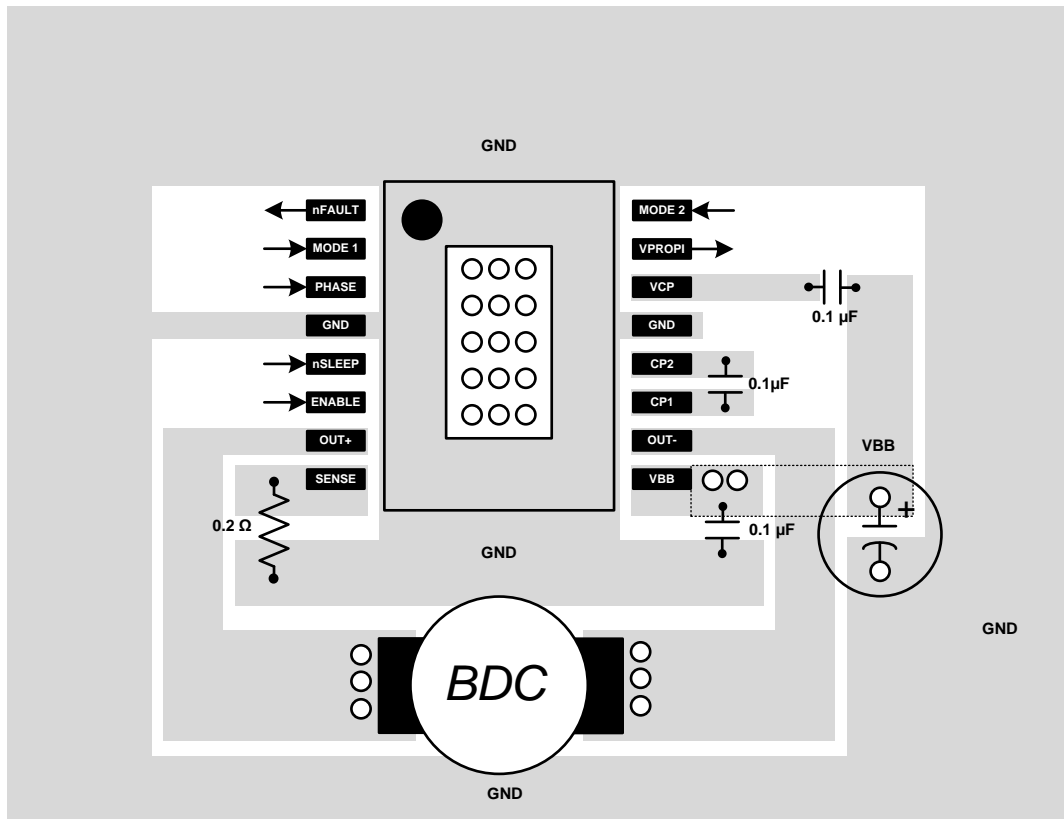

Figure 18. PWP Layout Example

## 13 Device and Documentation Support

### 13.1 Related Links

The table below lists quick access links. Categories include technical documents, support and community resources, tools and software, and quick access to sample or buy.

**Table 3. Related Links**

PARTS	PRODUCT FOLDER	SAMPLE & BUY	TECHNICAL DOCUMENTS	TOOLS & SOFTWARE	SUPPORT & COMMUNITY
DRV8800	<a href="#">Click here</a>	<a href="#">Click here</a>	<a href="#">Click here</a>	<a href="#">Click here</a>	<a href="#">Click here</a>
DRV8801	<a href="#">Click here</a>	<a href="#">Click here</a>	<a href="#">Click here</a>	<a href="#">Click here</a>	<a href="#">Click here</a>

### 13.2 Trademarks

PowerPAD is a trademark of Texas Instruments.  
All other trademarks are the property of their respective owners.

### 13.3 Electrostatic Discharge Caution



These devices have limited built-in ESD protection. The leads should be shorted together or the device placed in conductive foam during storage or handling to prevent electrostatic damage to the MOS gates.

### 13.4 Glossary

[SLYZ022](#) — *TI Glossary*.

This glossary lists and explains terms, acronyms, and definitions.

## 14 Mechanical, Packaging, and Orderable Information

The following pages include mechanical, packaging, and orderable information. This information is the most current data available for the designated devices. This data is subject to change without notice and revision of this document. For browser-based versions of this data sheet, refer to the left-hand navigation.

**PACKAGING INFORMATION**

Orderable Device	Status (1)	Package Type	Package Drawing	Pins	Package Qty	Eco Plan (2)	Lead/Ball Finish (6)	MSL Peak Temp (3)	Op Temp (°C)	Device Marking (4/5)	Samples
DRV8800PWP	ACTIVE	HTSSOP	PWP	16	90	Green (RoHS & no Sb/Br)	CU NIPDAU	Level-2-260C-1 YEAR	-40 to 85	DRV8800	<a href="#">Samples</a>
DRV8800PWPR	ACTIVE	HTSSOP	PWP	16	2000	Green (RoHS & no Sb/Br)	CU NIPDAU	Level-2-260C-1 YEAR	-40 to 85	DRV8800	<a href="#">Samples</a>
DRV8800RTYR	ACTIVE	QFN	RTY	16	3000	Green (RoHS & no Sb/Br)	CU NIPDAU	Level-3-260C-168 HR	-40 to 85	DRV 8800	<a href="#">Samples</a>
DRV8800RTYT	ACTIVE	QFN	RTY	16	250	Green (RoHS & no Sb/Br)	CU NIPDAU	Level-3-260C-168 HR	-40 to 85	DRV 8800	<a href="#">Samples</a>
DRV8801PWP	ACTIVE	HTSSOP	PWP	16	90	Green (RoHS & no Sb/Br)	CU NIPDAU	Level-2-260C-1 YEAR	-40 to 85	DRV8801	<a href="#">Samples</a>
DRV8801PWPR	ACTIVE	HTSSOP	PWP	16	2000	Green (RoHS & no Sb/Br)	CU NIPDAU	Level-2-260C-1 YEAR	-40 to 85	DRV8801	<a href="#">Samples</a>
DRV8801RTYR	ACTIVE	QFN	RTY	16	3000	Green (RoHS & no Sb/Br)	CU NIPDAU	Level-3-260C-168 HR	-40 to 85	DRV 8801	<a href="#">Samples</a>
DRV8801RTYT	ACTIVE	QFN	RTY	16	250	Green (RoHS & no Sb/Br)	CU NIPDAU	Level-3-260C-168 HR	-40 to 85	DRV 8801	<a href="#">Samples</a>

(1) The marketing status values are defined as follows:

**ACTIVE:** Product device recommended for new designs.

**LIFEBUY:** TI has announced that the device will be discontinued, and a lifetime-buy period is in effect.

**NRND:** Not recommended for new designs. Device is in production to support existing customers, but TI does not recommend using this part in a new design.

**PREVIEW:** Device has been announced but is not in production. Samples may or may not be available.

**OBSELETE:** TI has discontinued the production of the device.

(2) Eco Plan - The planned eco-friendly classification: Pb-Free (RoHS), Pb-Free (RoHS Exempt), or Green (RoHS & no Sb/Br) - please check <http://www.ti.com/productcontent> for the latest availability information and additional product content details.

**TBD:** The Pb-Free/Green conversion plan has not been defined.

**Pb-Free (RoHS):** TI's terms "Lead-Free" or "Pb-Free" mean semiconductor products that are compatible with the current RoHS requirements for all 6 substances, including the requirement that lead not exceed 0.1% by weight in homogeneous materials. Where designed to be soldered at high temperatures, TI Pb-Free products are suitable for use in specified lead-free processes.

**Pb-Free (RoHS Exempt):** This component has a RoHS exemption for either 1) lead-based flip-chip solder bumps used between the die and package, or 2) lead-based die adhesive used between the die and leadframe. The component is otherwise considered Pb-Free (RoHS compatible) as defined above.

**Green (RoHS & no Sb/Br):** TI defines "Green" to mean Pb-Free (RoHS compatible), and free of Bromine (Br) and Antimony (Sb) based flame retardants (Br or Sb do not exceed 0.1% by weight in homogeneous material)

(3) MSL, Peak Temp. - The Moisture Sensitivity Level rating according to the JEDEC industry standard classifications, and peak solder temperature.

(4) There may be additional marking, which relates to the logo, the lot trace code information, or the environmental category on the device.

(5) Multiple Device Markings will be inside parentheses. Only one Device Marking contained in parentheses and separated by a "~" will appear on a device. If a line is indented then it is a continuation of the previous line and the two combined represent the entire Device Marking for that device.

(6) Lead/Ball Finish - Orderable Devices may have multiple material finish options. Finish options are separated by a vertical ruled line. Lead/Ball Finish values may wrap to two lines if the finish value exceeds the maximum column width.

**Important Information and Disclaimer:**The information provided on this page represents TI's knowledge and belief as of the date that it is provided. TI bases its knowledge and belief on information provided by third parties, and makes no representation or warranty as to the accuracy of such information. Efforts are underway to better integrate information from third parties. TI has taken and continues to take reasonable steps to provide representative and accurate information but may not have conducted destructive testing or chemical analysis on incoming materials and chemicals. TI and TI suppliers consider certain information to be proprietary, and thus CAS numbers and other limited information may not be available for release.

In no event shall TI's liability arising out of such information exceed the total purchase price of the TI part(s) at issue in this document sold by TI to Customer on an annual basis.

**OTHER QUALIFIED VERSIONS OF DRV8801 :**

- Automotive: [DRV8801-Q1](#)

NOTE: Qualified Version Definitions:

- Automotive - Q100 devices qualified for high-reliability automotive applications targeting zero defects

**TAPE AND REEL INFORMATION**

**QUADRANT ASSIGNMENTS FOR PIN 1 ORIENTATION IN TAPE**

\*All dimensions are nominal

Device	Package Type	Package Drawing	Pins	SPQ	Reel Diameter (mm)	Reel Width W1 (mm)	A0 (mm)	B0 (mm)	K0 (mm)	P1 (mm)	W (mm)	Pin1 Quadrant
DRV8800PWPR	HTSSOP	PWP	16	2000	330.0	12.4	6.9	5.6	1.6	8.0	12.0	Q1
DRV8800RTYR	QFN	RTY	16	3000	330.0	12.4	4.25	4.25	1.15	8.0	12.0	Q2
DRV8800RTYT	QFN	RTY	16	250	180.0	12.4	4.25	4.25	1.15	8.0	12.0	Q2
DRV8801PWPR	HTSSOP	PWP	16	2000	330.0	12.4	6.9	5.6	1.6	8.0	12.0	Q1
DRV8801RTYR	QFN	RTY	16	3000	330.0	12.4	4.25	4.25	1.15	8.0	12.0	Q2
DRV8801RTYT	QFN	RTY	16	250	180.0	12.4	4.25	4.25	1.15	8.0	12.0	Q2

## TAPE AND REEL BOX DIMENSIONS



\*All dimensions are nominal

Device	Package Type	Package Drawing	Pins	SPQ	Length (mm)	Width (mm)	Height (mm)
DRV8800PWPR	HTSSOP	PWP	16	2000	350.0	350.0	43.0
DRV8800RTYR	QFN	RTY	16	3000	367.0	367.0	35.0
DRV8800RTYT	QFN	RTY	16	250	210.0	185.0	35.0
DRV8801PWPR	HTSSOP	PWP	16	2000	350.0	350.0	43.0
DRV8801RTYR	QFN	RTY	16	3000	367.0	367.0	35.0
DRV8801RTYT	QFN	RTY	16	250	210.0	185.0	35.0







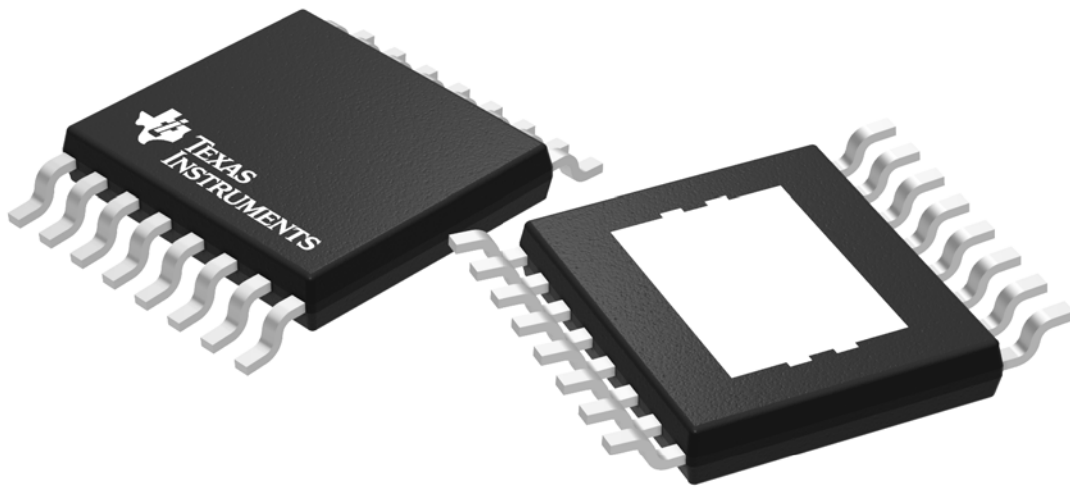

Images above are just a representation of the package family, actual package may vary.  
Refer to the product data sheet for package details.





# EXAMPLE STENCIL DESIGN

PWP0016B

PowerPAD™ TSSOP - 1.2 mm max height

PLASTIC SMALL OUTLINE

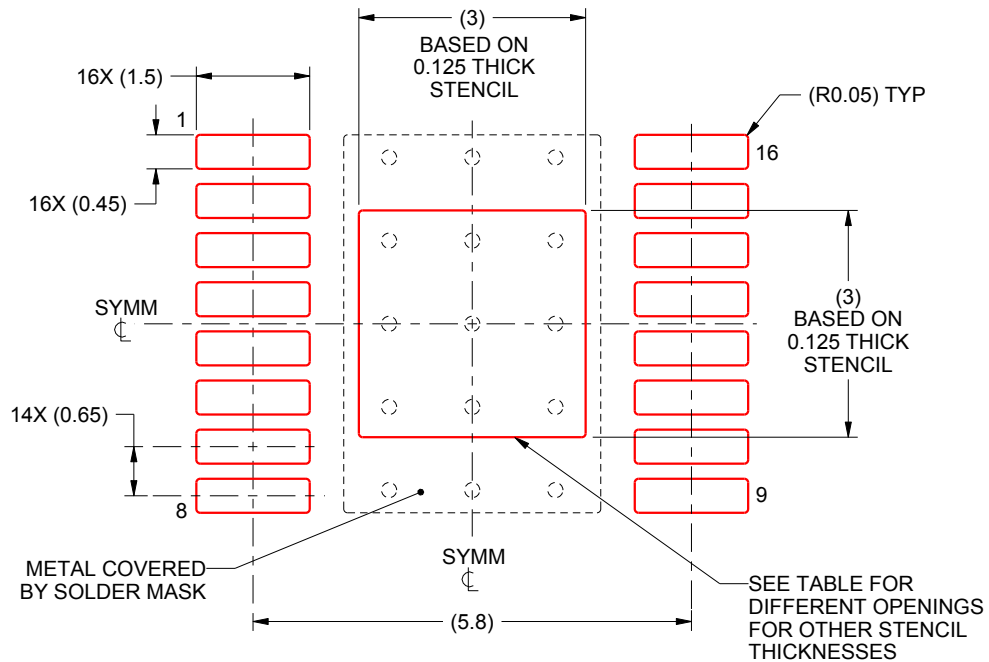

SOLDER PASTE EXAMPLE  
 EXPOSED PAD  
 100% PRINTED SOLDER COVERAGE BY AREA  
 SCALE:10X

STENCIL THICKNESS	SOLDER STENCIL OPENING
0.1	3.35 X 3.35
0.125	3 X 3 (SHOWN)
0.15	2.74 X 2.74
0.175	2.54 X 2.54

4218971/A 01/2016

NOTES: (continued)

- 10. Laser cutting apertures with trapezoidal walls and rounded corners may offer better paste release. IPC-7525 may have alternate design recommendations.
- 11. Board assembly site may have different recommendations for stencil design.

## IMPORTANT NOTICE AND DISCLAIMER

TI PROVIDES TECHNICAL AND RELIABILITY DATA (INCLUDING DATASHEETS), DESIGN RESOURCES (INCLUDING REFERENCE DESIGNS), APPLICATION OR OTHER DESIGN ADVICE, WEB TOOLS, SAFETY INFORMATION, AND OTHER RESOURCES "AS IS" AND WITH ALL FAULTS, AND DISCLAIMS ALL WARRANTIES, EXPRESS AND IMPLIED, INCLUDING WITHOUT LIMITATION ANY IMPLIED WARRANTIES OF MERCHANTABILITY, FITNESS FOR A PARTICULAR PURPOSE OR NON-INFRINGEMENT OF THIRD PARTY INTELLECTUAL PROPERTY RIGHTS.

These resources are intended for skilled developers designing with TI products. You are solely responsible for (1) selecting the appropriate TI products for your application, (2) designing, validating and testing your application, and (3) ensuring your application meets applicable standards, and any other safety, security, or other requirements. These resources are subject to change without notice. TI grants you permission to use these resources only for development of an application that uses the TI products described in the resource. Other reproduction and display of these resources is prohibited. No license is granted to any other TI intellectual property right or to any third party intellectual property right. TI disclaims responsibility for, and you will fully indemnify TI and its representatives against, any claims, damages, costs, losses, and liabilities arising out of your use of these resources.

TI's products are provided subject to TI's Terms of Sale ([www.ti.com/legal/termsofsale.html](http://www.ti.com/legal/termsofsale.html)) or other applicable terms available either on [ti.com](http://ti.com) or provided in conjunction with such TI products. TI's provision of these resources does not expand or otherwise alter TI's applicable warranties or warranty disclaimers for TI products.

Mailing Address: Texas Instruments, Post Office Box 655303, Dallas, Texas 75265  
Copyright © 2019, Texas Instruments Incorporated

## Looking for pricing, stock, or lifecycle information?

Click below to explore more details on WIN SOURCE:

 [View DRV8801RTYT](#) on WIN SOURCE

 [Texas Instruments](#) Information

## Optimize Your Supply Chain with WIN SOURCE Solutions

-  Global Sourcing Solution
-  Obsolete Management
-  Cost Control Management
-  Shortage Management
-  Alternative Solution
-  Excess Inventory Management