



**THE DATASHEET OF  
AUIRS44261S**



**Automotive Grade**  
**AUIRS44261S**  
**DUAL LOW SIDE DRIVER**

**Features**

- Gate drive supply range from 4.8 V to 20 V
- CMOS Schmitt-triggered inputs
- Matched propagation delay for both channels
- Outputs out of phase with inputs
- Automotive Qualified<sup>†</sup>
- Leadfree, RoHS compliant

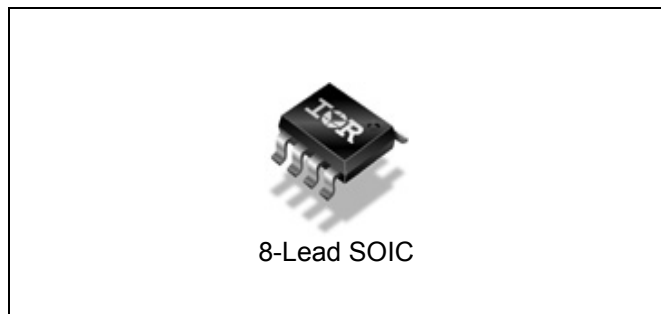
**Typical Applications**

- Automotive General Purpose Dual Low Side Driver
- Automotive DC-DC converters
- Hybrid Power Train Drives
- Direct Fuel Injection

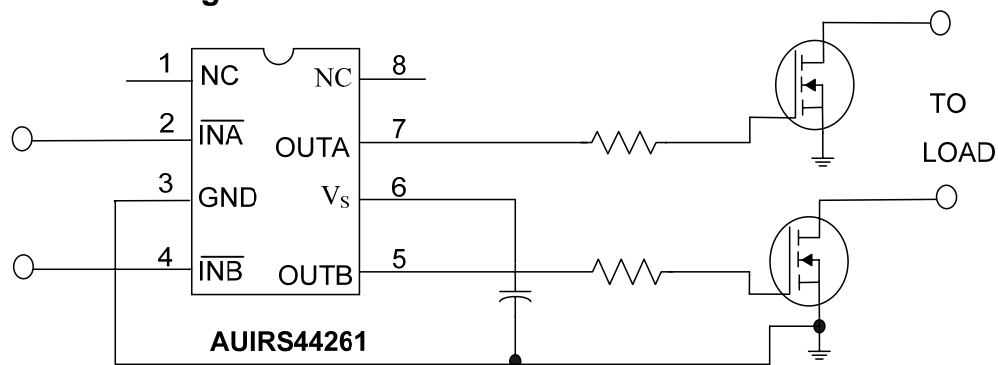
**Product Summary**

Topology	Dual Low Side Driver
V <sub>OUT</sub>	4.8 V – 20 V
I <sub>o+</sub> & I <sub>o-</sub> (typical)	2.3 A & 3.3 A
t <sub>ON</sub> & t <sub>OFF</sub> (typical)	70 ns & 65 ns

**Package**



**Typical Connection Diagram**



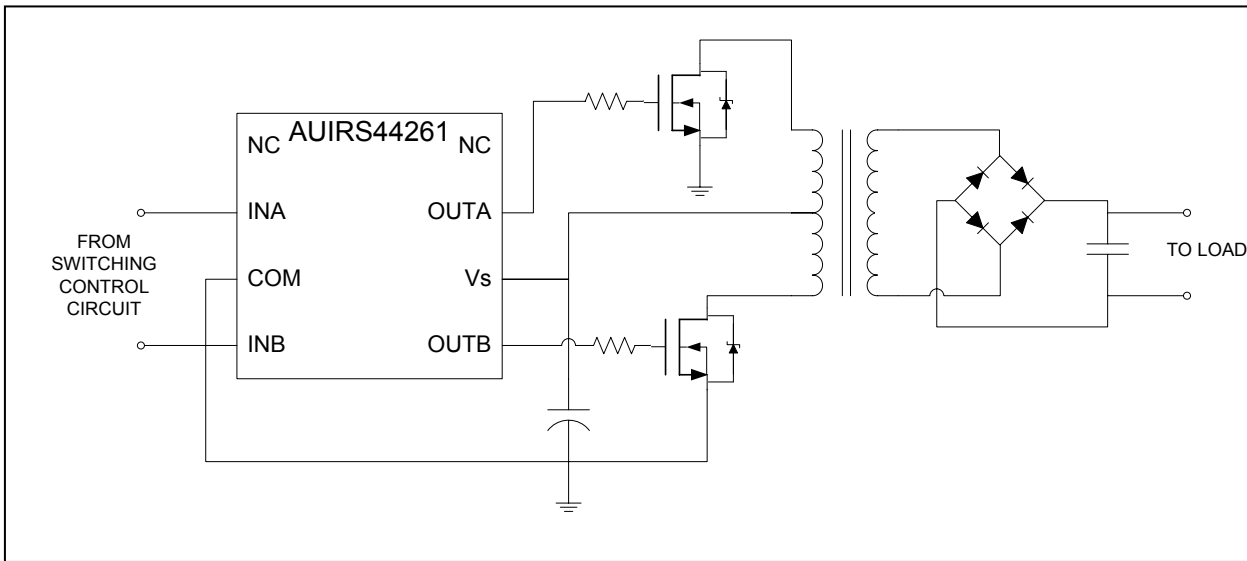
(Please refer to our Application Notes and Design Tips for proper circuit board layout)

<b>Table of Contents</b>	<b>Page</b>
Typical Connection Diagram	1
Description	3
Diagram for push-pull forward DC-DC converter application	3
Qualification Information	4
Absolute Maximum Ratings	5
Recommended Operating Conditions	5
Static Electrical Characteristics	6-7
Dynamic Electrical Characteristics	6-7
Functional Block Diagram	8
Input/Output Pin Equivalent Circuit Diagrams	9
Lead Definitions	10
Lead Assignments	10
Input/output Timing Diagram	11
Switching Time Waveform Definitions	11
Advance Configuration	11
Parameter Temperature Trends	12-15
Package Details	16
Tape and Reel Details	17
Part Marking Information	18
Ordering Information	19
Important Notice	20

**Description**

The AUIRS44261 is a low voltage, high speed power MOSFET and IGBT driver. Proprietary latch immune CMOS technologies enable ruggedized monolithic construction. The logic inputs thresholds are proportional to  $V_s$  supply voltage.. The output drivers feature a high pulse current buffer stage designed for minimum driver cross-conduction. Propagation delays between two channels are matched.

**Diagram for push-pull forward DC-DC converter application**



**Qualification Information<sup>†</sup>**

<b>Qualification Level</b>		Automotive (per AEC-Q100 <sup>††</sup> )	
		Comments: This family of ICs has passed an Automotive qualification. IR's Industrial and Consumer qualification level is granted by extension of the higher Automotive level.	
<b>Moisture Sensitivity Level</b>		SOIC8N	MSL3 <sup>†††</sup> 260°C (per IPC/JEDEC J-STD-020)
<b>ESD</b>	Machine Model	Class M2 (+/-200V) (per AEC-Q100-003)	
	Human Body Model	Class H2 (+/-4000V) (per AEC-Q100-002)	
	Charged Device Model	Class C4 (+/-1000V) (per AEC-Q100-011)	
IC Latch-Up Test		Class II Level B <sup>††††</sup> (per AEC-Q100-004)	
<b>RoHS Compliant</b>		Yes	

† Qualification standards can be found at International Rectifier's web site <http://www.irf.com/>

†† Exceptions (if any) to AEC-Q100 requirements are noted in the qualification report.

††† Higher MSL ratings may be available for the specific package types listed here. Please contact your International Rectifier sales representative for further information.

†††† INA and INB stressed to +/-40mA

**Absolute Maximum Ratings**

Absolute Maximum Ratings indicate sustained limits beyond which damage to the device may occur. All voltage parameters are absolute voltages referenced to GND lead. Stresses beyond those listed under "Absolute Maximum Ratings" may cause permanent damage to the device. These are stress ratings only; and functional operation of the device at these or any other condition beyond those indicated in the "Recommended Operating Conditions" is not implied. Exposure to absolute-maximum-rated conditions for extended periods may affect device reliability. The thermal resistance and power dissipation ratings are measured under board mounted and still air conditions. Ambient temperature ( $T_A$ ) is 25°C, unless otherwise specified.

Symbol	Definition	Min.	Max.	Units
$V_S$	Fixed supply voltage	-0.3	25	V
$V_O$	Output voltage	-0.3	$V_S + 0.3$	
$V_{IN}$	Logic input voltage	-0.3	$V_S + 0.3$	
$P_D$	Package power dissipation @ $T_A \leq 25^\circ\text{C}$	—	0.625	W
$R_{thJA}$	Thermal resistance, junction to ambient	—	200	$^\circ\text{C}/\text{W}$
$T_J$	Junction temperature	—	150	$^\circ\text{C}$
$T_S$	Storage temperature	-55	150	
$T_L$	Lead temperature (soldering, 10 seconds)	—	300	

**Recommended Operating Conditions**

The input/output logic timing diagram is shown in Figure 1. For proper operation the device should be used within the recommended conditions. All voltage parameters are absolute voltage referenced to GND.

Symbol	Definition	Min.	Max.	Units
$V_S$	Fixed supply voltage	4.8	20	V
$V_O$	Output voltage	0	$V_S$	
$V_{IN}$	Logic input voltage	0	$V_S$	
$T_A$	Ambient temperature	-40	125	$^\circ\text{C}$

### Static Electrical Characteristics

Unless otherwise noted, these specifications apply for an operating junction temperature range of  $-40^{\circ}\text{C} \leq T_j \leq 125^{\circ}\text{C}$  with bias conditions of  $V_{\text{BIAS}} (V_S) = 15\text{ V}$ . The  $V_{\text{IN}}$  and  $I_{\text{IN}}$  parameters are referenced to GND and are applicable to input leads: INA and INB. The  $V_{\text{O}}$  and  $I_{\text{O}}$  parameters are referenced to GND and are applicable to the output leads: OUTA and OUTB.

Symbol	Definition	Min	Typ	Max	Units	Test Conditions
$V_{\text{IH}}$	Logic "0" input voltage	$0.5 * V_S + 0.3\text{V}$	—	—	V	$4.8\text{V} < V_S < 20\text{V}$
$V_{\text{IL}}$	Logic "1" input voltage	—	—	$0.15 * V_S + 0.08\text{V}$		
$V_{\text{OH}}$	High level output voltage, $V_{\text{BIAS}} - V_{\text{O}}$	—	—	1.4		$I_{\text{O}} = 0\text{ mA}$
$V_{\text{OL}}$	Low level output voltage, $V_{\text{O}}$	—	—	0.1		
$I_{\text{IN+}}$	Logic "1" input bias current (OUT = HI)	—	15	25	$\mu\text{A}$	$V_{\text{IN}} = 0\text{ V}$
$I_{\text{IN-}}$	Logic "0" input bias current (OUT = LO)	—	0	1		$V_{\text{IN}} = V_S$
$I_{\text{QB}}$	Quiescent $V_S$ supply current	—	70	220		$V_{\text{IN}} = 0\text{ V}$ or $V_S$
$I_{\text{O+}}$	Output high short circuit pulsed current <sup>(†)</sup>	1.5	2.3	—	A	$V_{\text{O}} = 0\text{ V}$ , $V_{\text{IN}} = 0$ $\text{PW} \leq 10\ \mu\text{s}$
$I_{\text{O-}}$	Output high short circuit pulsed current <sup>(†)</sup>	1.5	3.3	—		$V_{\text{O}} = 15\text{ V}$ , $V_{\text{IN}} = V_S$ $\text{PW} \leq 10\ \mu\text{s}$

(†) Guaranteed by design

### Dynamic Electrical Characteristics

Unless otherwise noted, these specifications apply for an operating junction temperature range of  $-40^{\circ}\text{C} \leq T_j \leq 125^{\circ}\text{C}$  with bias conditions of  $V_{\text{BIAS}} (V_S) = 15\text{ V}$ ,  $\text{CL} = 1000\text{pF}$ . The dynamic electrical characteristics are measured using the test circuit shown in Fig. 3.

Symbol	Definition	Min	Typ	Max	Units	Test Conditions
<b>Propagation delay characteristics</b>						
$t_{\text{d1}}$	Turn-on propagation delay	—	70	150	ns	Figure 2
$t_{\text{d2}}$	Turn-off propagation delay	—	65	150		
$t_{\text{r}}$	Turn-on rise time	—	15	35		
$t_{\text{f}}$	Turn-off fall time	—	25	50		

**Static Electrical Characteristics Vs=4.8V**

Unless otherwise noted, these specifications apply for an operating junction temperature range of  $-40^{\circ}\text{C} \leq T_j \leq 125^{\circ}\text{C}$  with bias conditions of  $V_{\text{BIAS}} (V_S) = 4.8 \text{ V}$ . The  $V_{\text{IN}}$  and  $I_{\text{IN}}$  parameters are referenced to GND and are applicable to input leads: INA and INB. The  $V_{\text{O}}$  and  $I_{\text{O}}$  parameters are referenced to GND and are applicable to the output leads: OUTA and OUTB.

Symbol	Definition	Min	Typ	Max	Units	Test Conditions
$V_{\text{IH}}$	Logic "0" input voltage	2.7	—	—	V	
$V_{\text{IL}}$	Logic "1" input voltage	—	—	0.8	V	
$V_{\text{OH}25}$	High level output voltage, $V_{\text{BIAS}} - V_{\text{O}}$	—	—	1.6	V	$I_{\text{O}} = 2 \text{ mA}$ , $T_j = 25^{\circ}\text{C}$
$V_{\text{OH}40}$	High level output voltage, $V_{\text{BIAS}} - V_{\text{O}}$	—	—	2.2	V	$I_{\text{O}} = 2 \text{ mA}$ , $T_j = -40^{\circ}\text{C}$
$V_{\text{OH}125}$	High level output voltage, $V_{\text{BIAS}} - V_{\text{O}}$	—	—	1.6	V	$I_{\text{O}} = 2 \text{ mA}$ , $T_j = 125^{\circ}\text{C}$
$V_{\text{OL}}$	Low level output voltage, $V_{\text{O}}$	—	—	0.1	V	$I_{\text{O}} = 2 \text{ mA}$
$I_{\text{IN}+}$	Logic "1" input bias current (OUT = HI)	—	5	10	$\mu\text{A}$	$V_{\text{IN}} = 0 \text{ V}$
$I_{\text{IN}-}$	Logic "0" input bias current (OUT = LO)	—	0	1		$V_{\text{IN}} = V_S$
$I_{\text{QB}}$	Quiescent $V_S$ supply current	—	25	45		$V_{\text{IN}} = 0 \text{ V}$ or $V_S$
$I_{\text{O}+}$	Output high short circuit pulsed current <sup>(†)</sup>	430	640	—	mA	$V_{\text{O}} = 0 \text{ V}$ , $V_{\text{IN}} = 0$ $\text{PW} \leq 10 \mu\text{s}$
$I_{\text{O}-}$	Output high short circuit pulsed current <sup>(†)</sup>	530	850	—		$V_{\text{O}} = 4.8 \text{ V}$ , $V_{\text{IN}} = V_S$ $\text{PW} \leq 10 \mu\text{s}$

(†) Guaranteed by design

**Dynamic Electrical Characteristics Vs=4.8V**

Unless otherwise noted, these specifications apply for an operating junction temperature range of  $-40^{\circ}\text{C} \leq T_j \leq 125^{\circ}\text{C}$  with bias conditions of  $V_{\text{BIAS}} (V_S) = 4.8 \text{ V}$ ,  $\text{CL} = 1000\text{pF}$ . The dynamic electrical characteristics are measured using the test circuit shown in Fig. 3.

Symbol	Definition	Min	Typ	Max	Units	Test Conditions
<b>Propagation delay characteristics</b>						
$t_{\text{d}1}$	Turn-on propagation delay (note 1)	—	130	220	ns	Figure 2
$t_{\text{d}2}$	Turn-off propagation delay (note 2)	—	150	250		
$t_{\text{r}}$	Turn-on rise time (note 3)	—	40	75		
$t_{\text{f}}$	Turn-off fall time (note 4)	—	50	75		

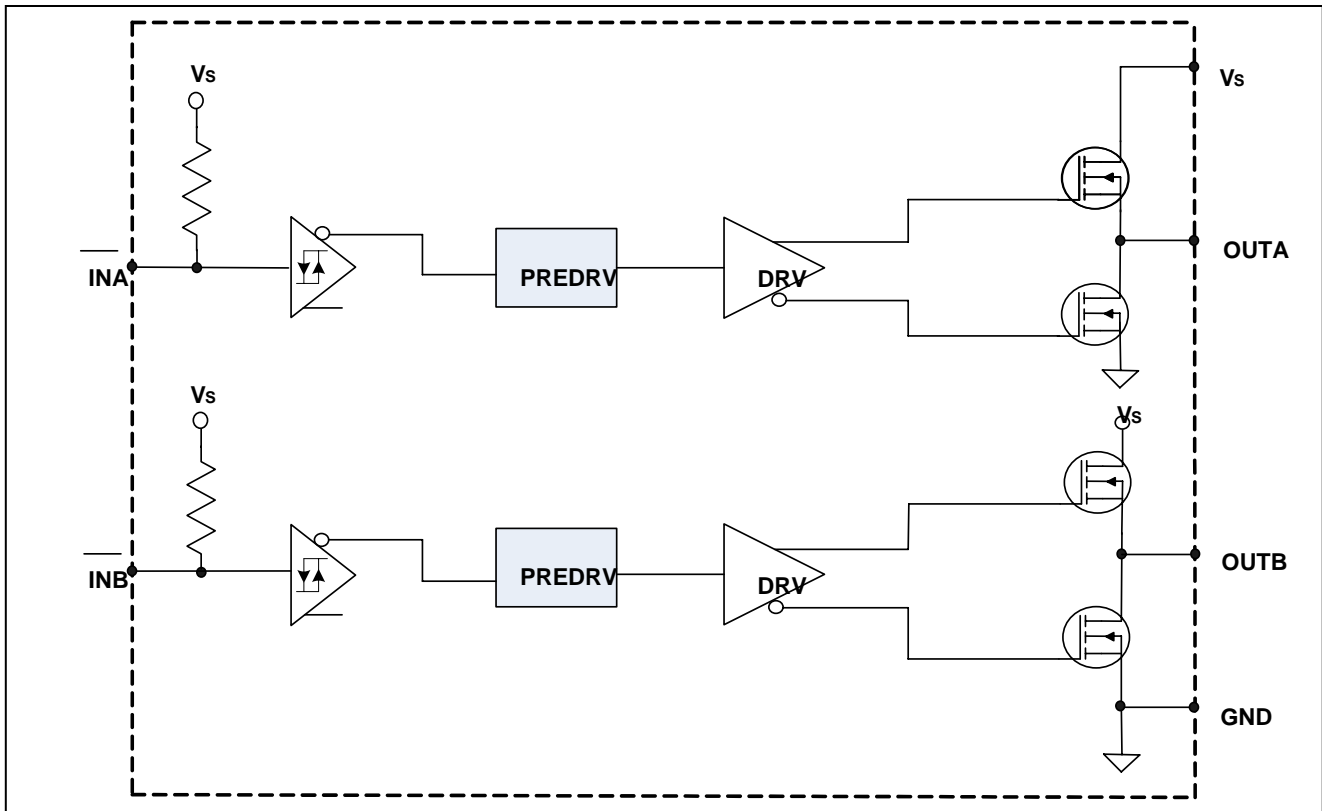
(note 1) from 50% input to 25% output

(note 2) from 50% input to 75% output

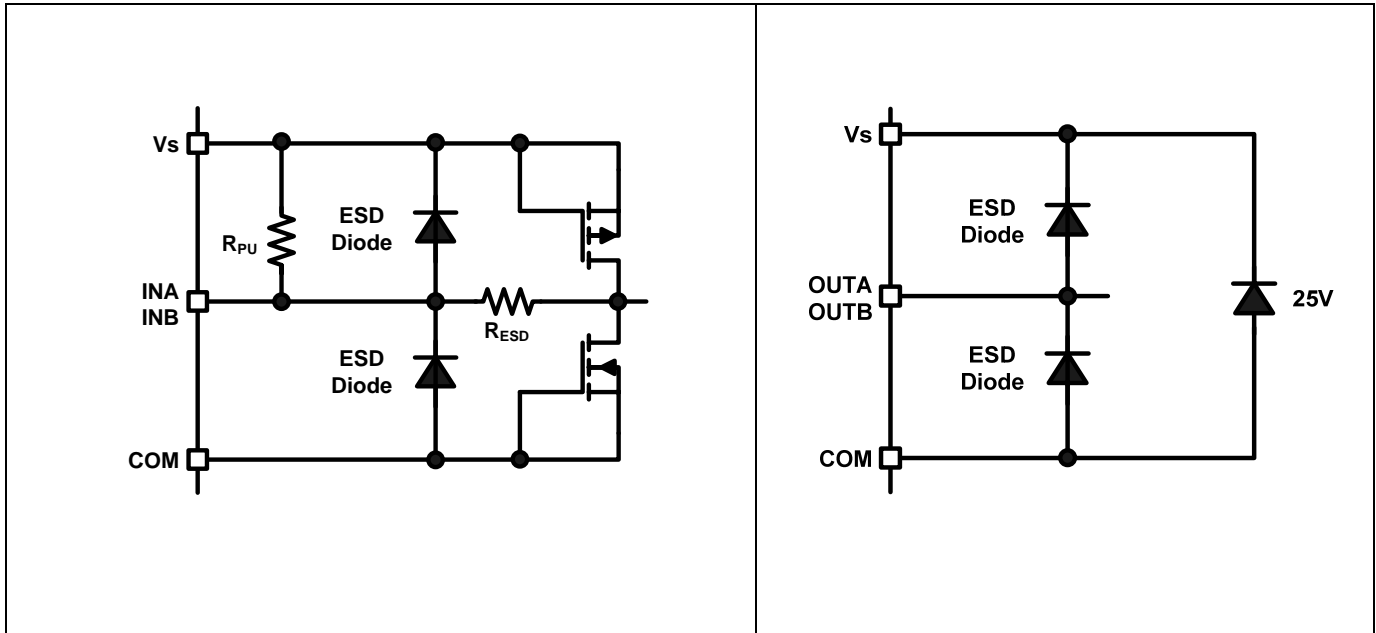
(note 3) from 10% to 65%

(note4) from 65% to 10%

## Functional Block Diagram: AUIRS44261



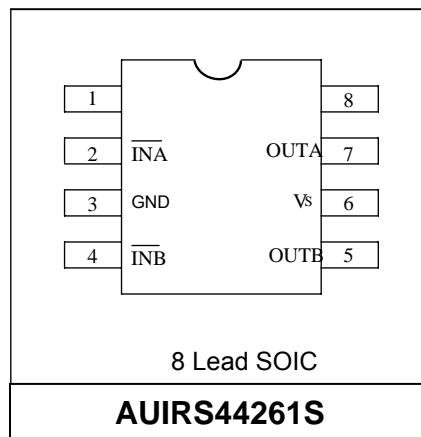
**Input/Output Pin Equivalent Circuit Diagrams:**



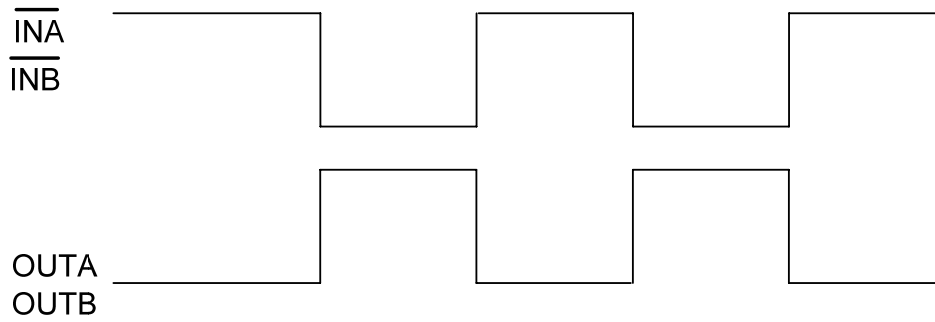
**Lead Definitions**

Symbol	Description
$V_s$	Supply voltage
<b>GND</b>	Ground
$\overline{\text{INA}}$	Logic input for gate driver output (OUTA), out of phase
$\overline{\text{INB}}$	Logic input for gate driver output (OUTB), out of phase
<b>OUTA</b>	Gate drive output A
<b>OUTB</b>	Gate drive output B

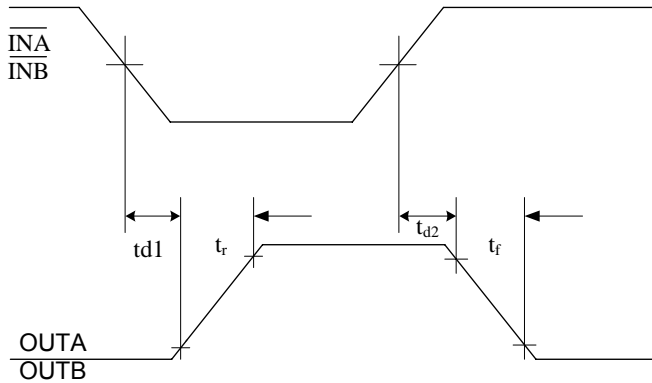
**Lead Assignments**



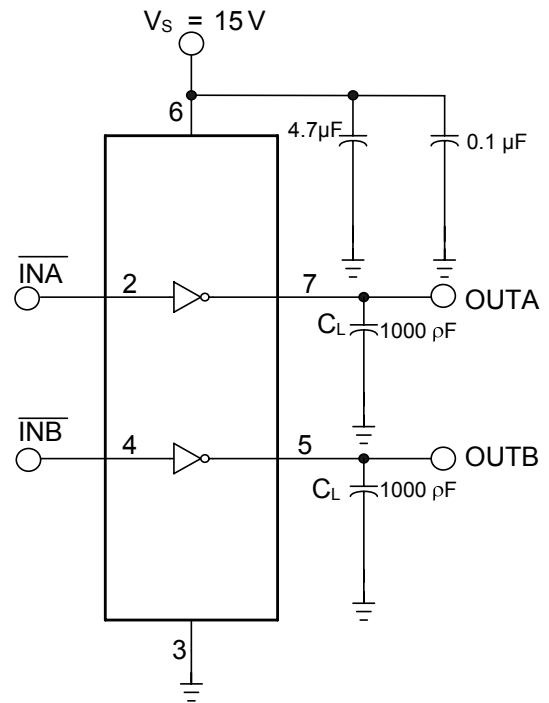
**Application Information and Additional Details**



**Figure 1: Input/output Timing Diagram**



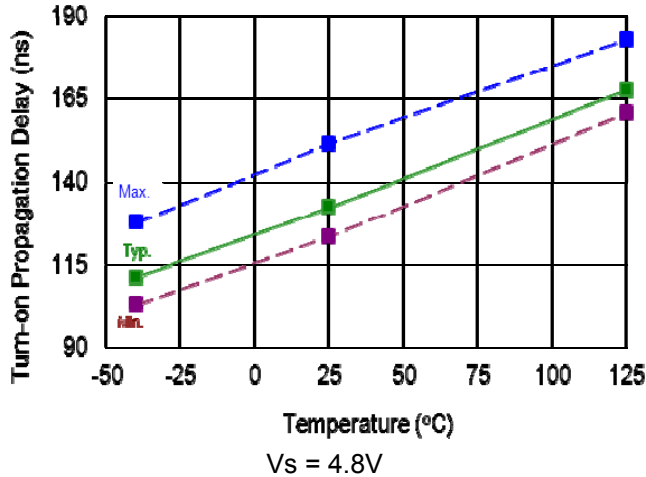
**Figure 2: Switching Time Waveform Definitions**



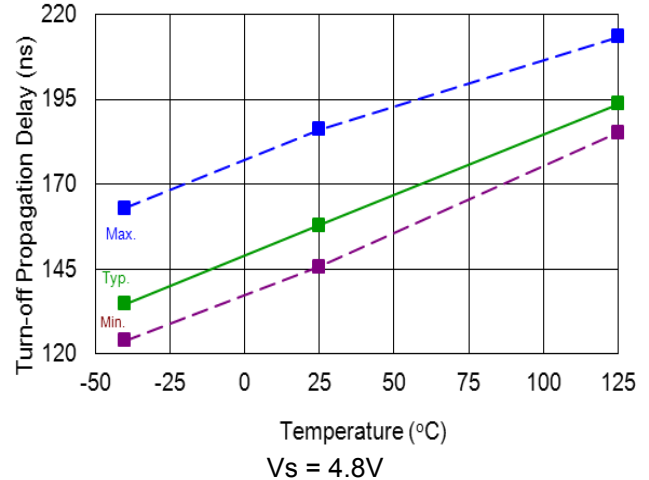
**Figure 3: Advance Configuration**

**Parameter Trends vs. Temperature**

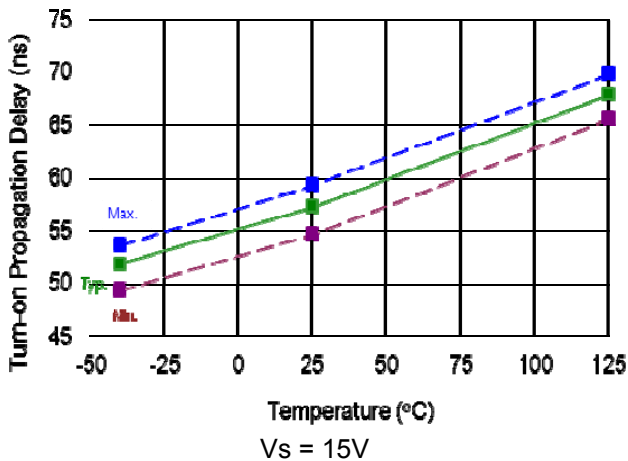
Figures illustrated in this chapter provide information on the experimental performance of the AUIRS44261S HVIC. The line plotted in each figure is generated from actual lab data. A large number of individual samples were tested at three temperatures (-40 °C, 25 °C, and 125 °C) with supply voltage of 15V in order to generate the experimental curve. The line consists of three data points (one data point at each of the tested temperatures) that have been connected together to illustrate the understood trend. The individual data points on the Typ. curve were determined by calculating the averaged experimental value of the parameter (for a given temperature).



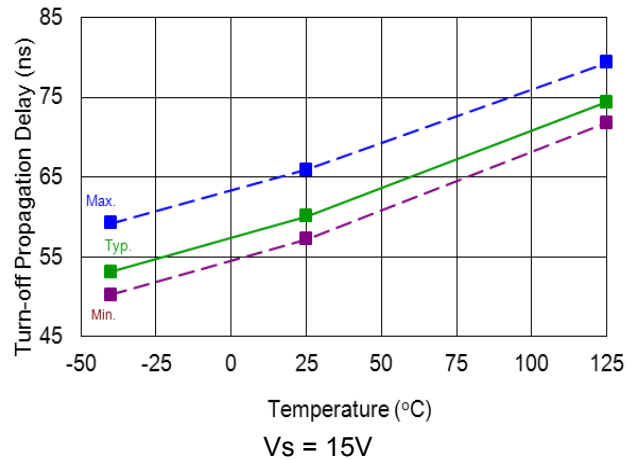
**Figure 4.** Turn-On Propagation Delay vs. Temperature



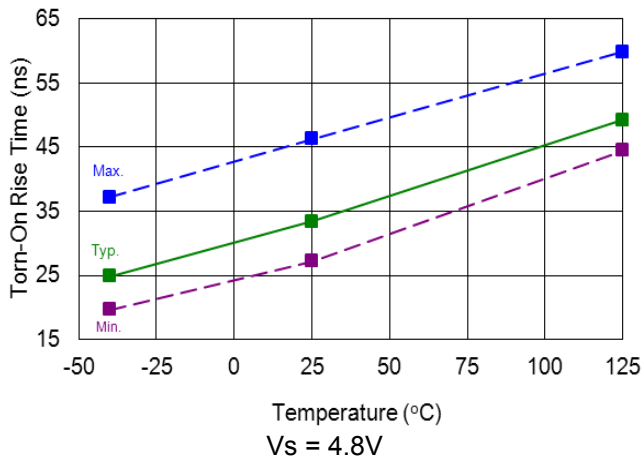
**Figure 5.** Turn-Off Propagation Delay vs. Temperature



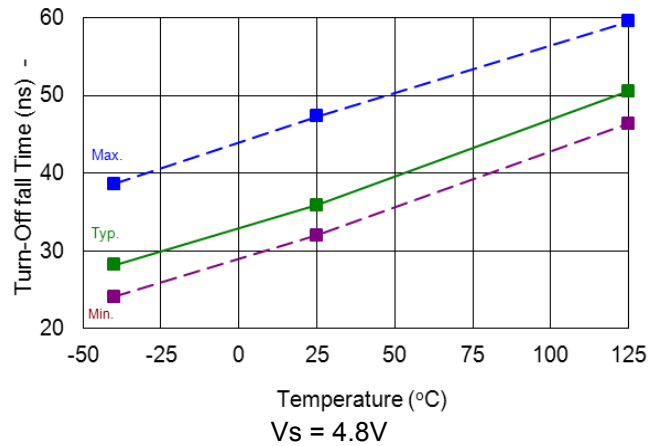
**Figure 6.** Turn-On Propagation Delay vs. Temperature



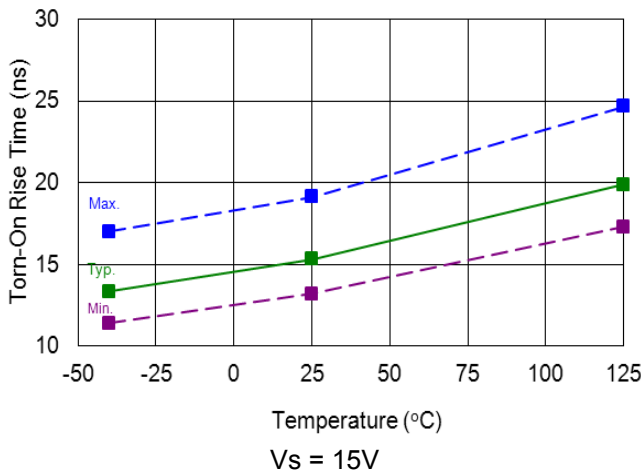
**Figure 7.** Turn-Off Propagation Delay vs. Temperature



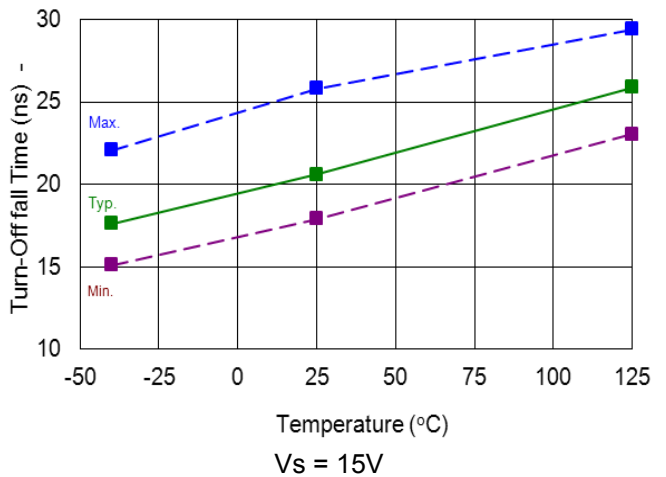
**Figure 8.** Turn-On Rise Time vs. Temperature



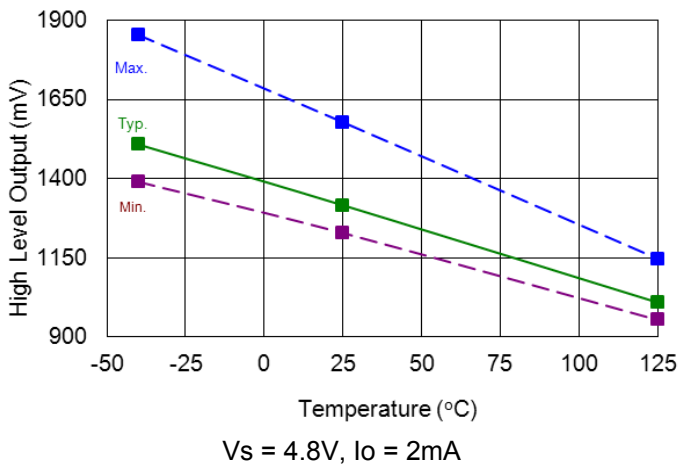
**Figure 9.** Turn-Off Fall Time vs. Temperature



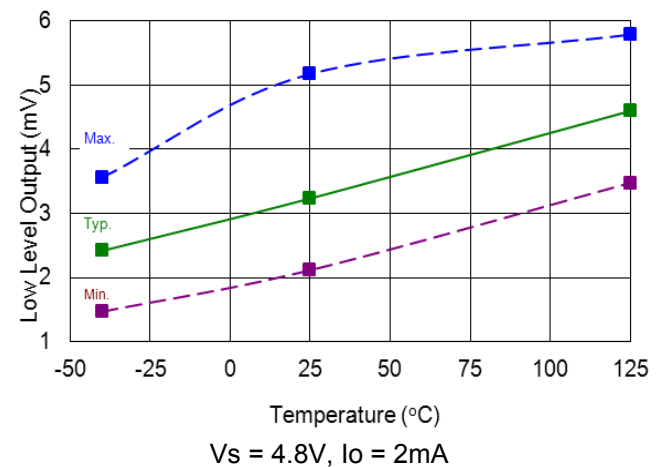
**Figure 10.** Turn-On Rise Time vs. Temperature



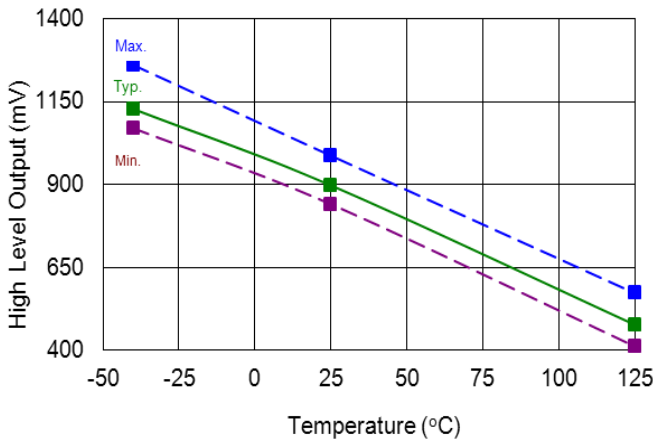
**Figure 11.** Turn-Off Fall Time vs. Temperature



**Figure 12.** High Level Output Voltage vs. Temperature

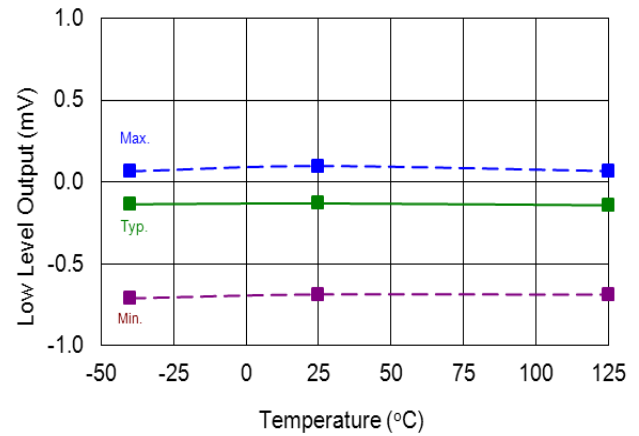


**Figure 13.** Low Level Output Voltage vs. Temperature



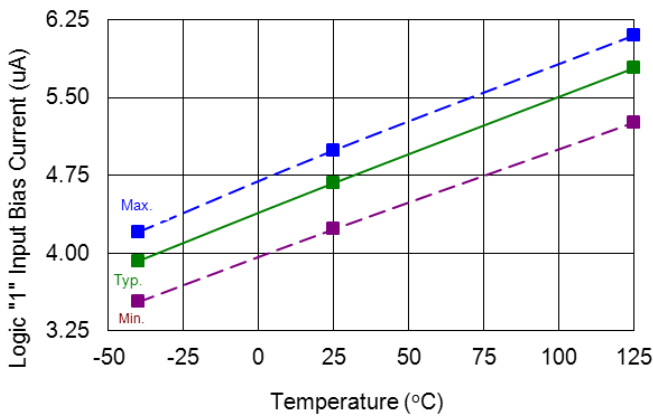
$V_s = 15V, I_o = 0mA$

**Figure 14.** High Level Output Voltage vs. Temperature



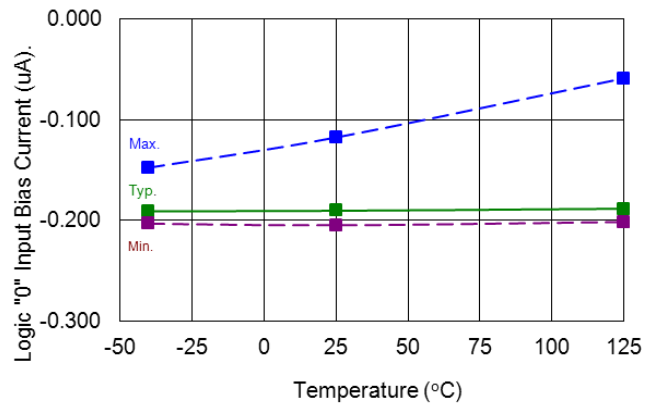
$V_s = 15V, I_o = 0mA$

**Figure 15.** Low Level Output Voltage vs. Temperature



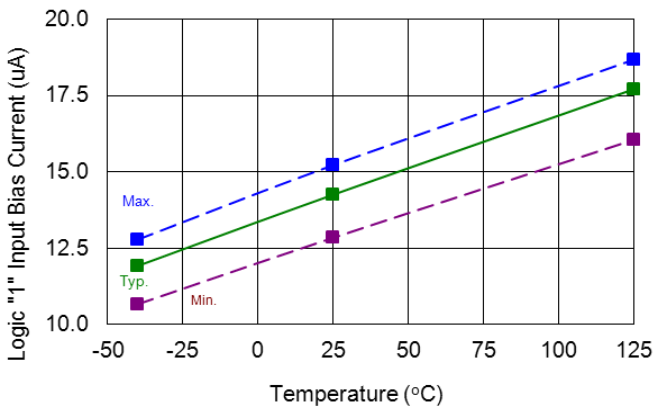
$V_s = 4.8V$

**Figure 16.** Logic "1" Input Bias Current vs. Temperature



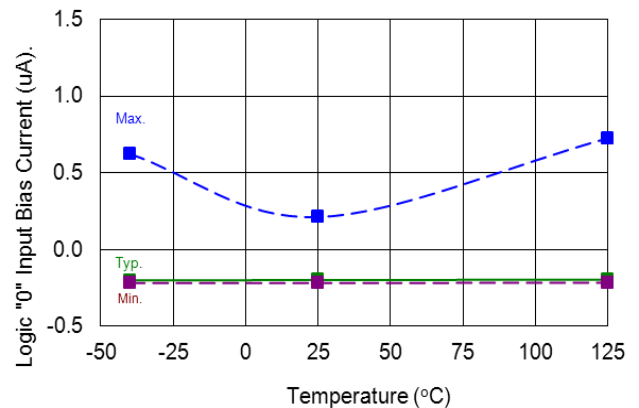
$V_s = 4.8V$

**Figure 17.** Logic "0" Input Bias Current vs. Temperature



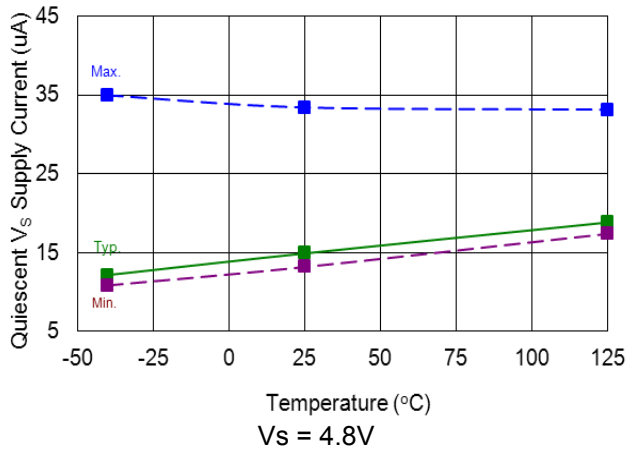
$V_s = 15V$

**Figure 18.** Logic "1" Input Bias Current vs. Temperature

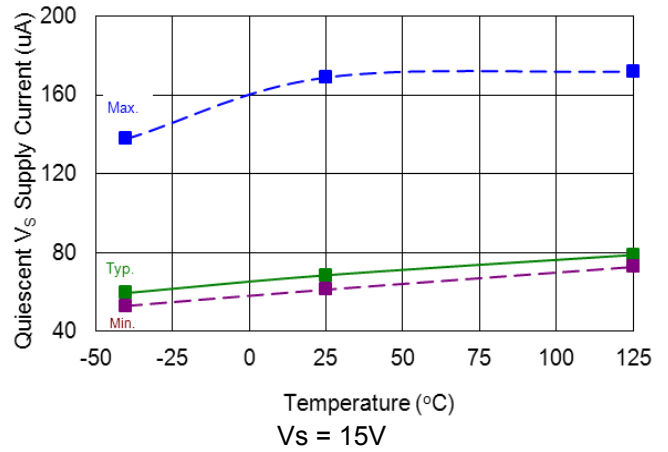


$V_s = 15V$

**Figure 19.** Logic "0" Input Bias Current vs. Temperature

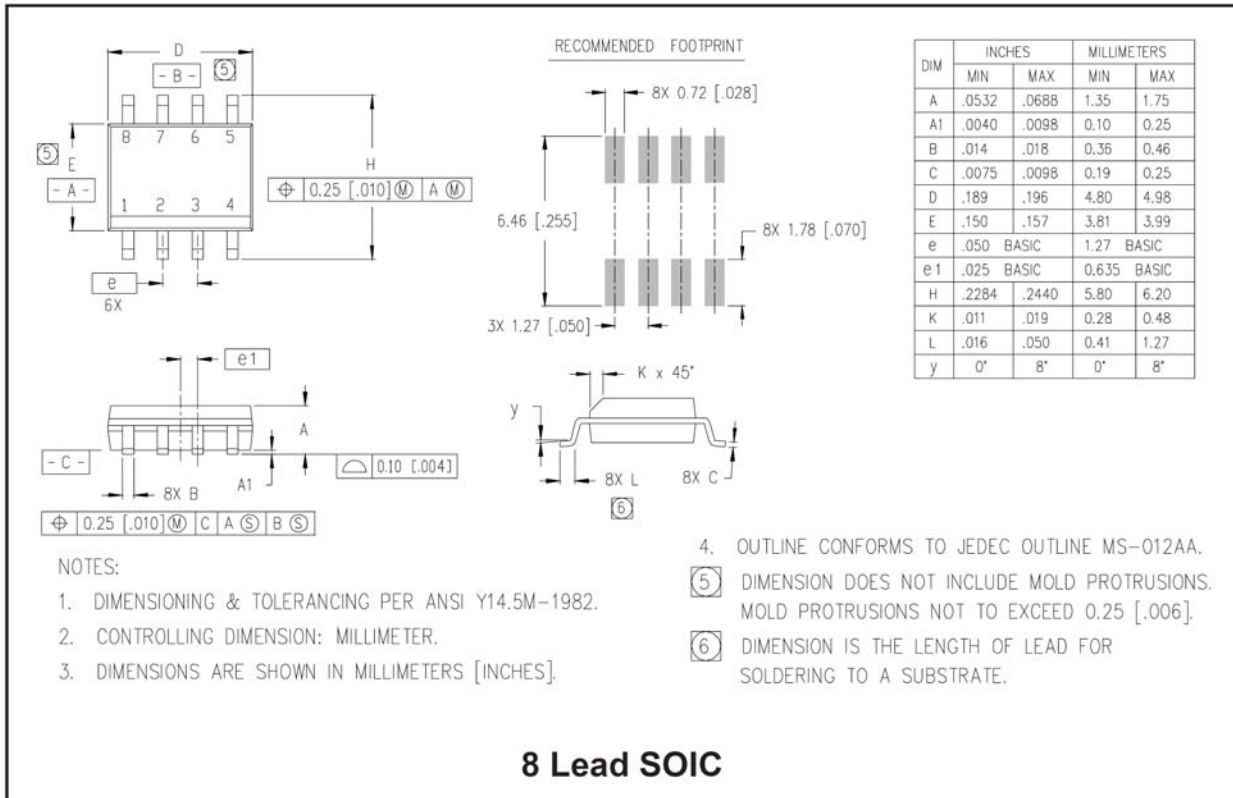


**Figure 20.** Quiescent  $V_S$  Supply Current vs. Temperature

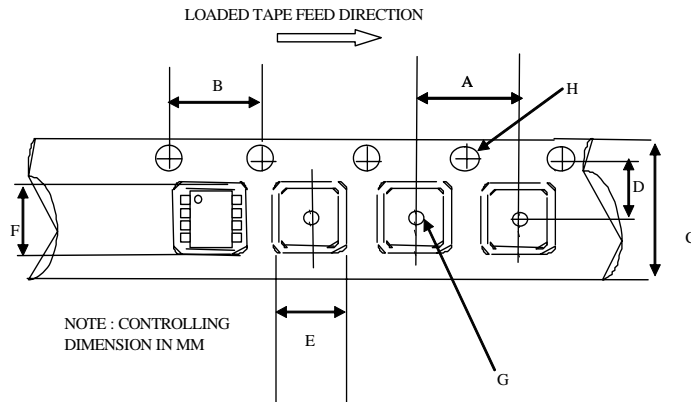


**Figure 21.** Quiescent  $V_S$  Supply Current vs. Temperature

**Package Details: SOIC8**

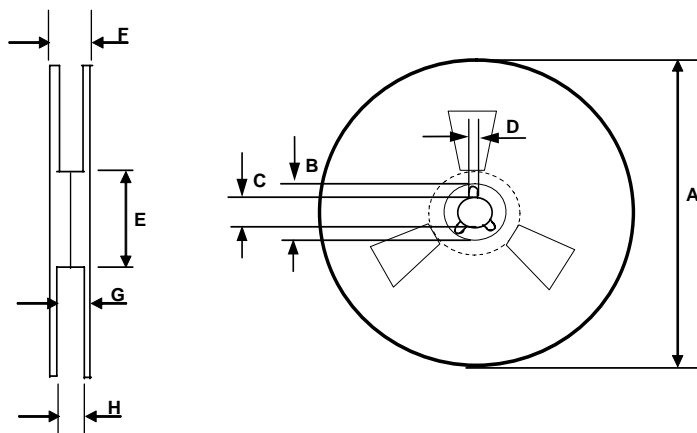


**Tape and Reel Details: SOIC8**



CARRIER TAPE DIMENSION FOR 8SOICN

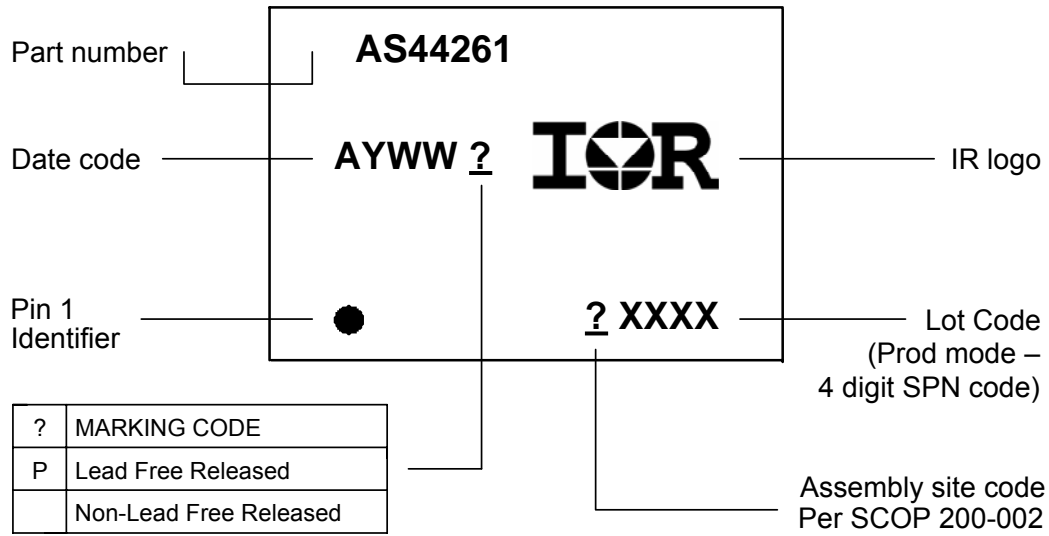
Code	Metric		Imperial	
	Min	Max	Min	Max
A	7.90	8.10	0.311	0.318
B	3.90	4.10	0.153	0.161
C	11.70	12.30	0.46	0.484
D	5.45	5.55	0.214	0.218
E	6.30	6.50	0.248	0.255
F	5.10	5.30	0.200	0.208
G	1.50	n/a	0.059	n/a
H	1.50	1.60	0.059	0.062



REEL DIMENSIONS FOR 8SOICN

Code	Metric		Imperial	
	Min	Max	Min	Max
A	329.60	330.25	12.976	13.001
B	20.95	21.45	0.824	0.844
C	12.80	13.20	0.503	0.519
D	1.95	2.45	0.767	0.096
E	98.00	102.00	3.858	4.015
F	n/a	18.40	n/a	0.724
G	14.50	17.10	0.570	0.673
H	12.40	14.40	0.488	0.566

**Part Marking Information**



**Ordering Information**

Base Part Number	Package Type	Standard Pack		Complete Part Number
		Form	Quantity	
AUIRS44261	SOIC8	Tube/Bulk	95	AUIRS44261S
		Tape and Reel	2500	AUIRS44261STR

**IMPORTANT NOTICE**

Unless specifically designated for the automotive market, International Rectifier Corporation and its subsidiaries (IR) reserve the right to make corrections, modifications, enhancements, improvements, and other changes to its products and services at any time and to discontinue any product or services without notice. Part numbers designated with the "AU" prefix follow automotive industry and / or customer specific requirements with regards to product discontinuance and process change notification. All products are sold subject to IR's terms and conditions of sale supplied at the time of order acknowledgment.

IR warrants performance of its hardware products to the specifications applicable at the time of sale in accordance with IR's standard warranty. Testing and other quality control techniques are used to the extent IR deems necessary to support this warranty. Except where mandated by government requirements, testing of all parameters of each product is not necessarily performed.

IR assumes no liability for applications assistance or customer product design. Customers are responsible for their products and applications using IR components. To minimize the risks with customer products and applications, customers should provide adequate design and operating safeguards.

Reproduction of IR information in IR data books or data sheets is permissible only if reproduction is without alteration and is accompanied by all associated warranties, conditions, limitations, and notices. Reproduction of this information with alterations is an unfair and deceptive business practice. IR is not responsible or liable for such altered documentation. Information of third parties may be subject to additional restrictions.

Resale of IR products or serviced with statements different from or beyond the parameters stated by IR for that product or service voids all express and any implied warranties for the associated IR product or service and is an unfair and deceptive business practice. IR is not responsible or liable for any such statements.

IR products are not designed, intended, or authorized for use as components in systems intended for surgical implant into the body, or in other applications intended to support or sustain life, or in any other application in which the failure of the IR product could create a situation where personal injury or death may occur. Should Buyer purchase or use IR products for any such unintended or unauthorized application, Buyer shall indemnify and hold International Rectifier and its officers, employees, subsidiaries, affiliates, and distributors harmless against all claims, costs, damages, and expenses, and reasonable attorney fees arising out of, directly or indirectly, any claim of personal injury or death associated with such unintended or unauthorized use, even if such claim alleges that IR was negligent regarding the design or manufacture of the product.

Only products certified as military grade by the Defense Logistics Agency (DLA) of the US Department of Defense, are designed and manufactured to meet DLA military specifications required by certain military, aerospace or other applications. Buyers acknowledge and agree that any use of IR products not certified by DLA as military-grade, in applications requiring military grade products, is solely at the Buyer's own risk and that they are solely responsible for compliance with all legal and regulatory requirements in connection with such use.

IR products are neither designed nor intended for use in automotive applications or environments unless the specific IR products are designated by IR as compliant with ISO/TS 16949 requirements and bear a part number including the designation "AU". Buyers acknowledge and agree that, if they use any non-designated products in automotive applications, IR will not be responsible for any failure to meet such requirements.

For technical support, please contact IR's Technical Assistance Center  
<http://www.irf.com/technical-info/>

**WORLD HEADQUARTERS:**  
101 N. Sepulveda Blvd., El Segundo, California 90245  
Tel: (310) 252-7105

**Revision History**

<b>Date</b>	<b>Comment</b>
04/29/08	Draft
03/13/09	Front page Typ Application and diagram.
07/07/09	Removed PDIP8 and AUIRS4427, AUIRS4428
09/30/09	Reformatted entire data sheet, added part marking
01/06/09	Updated Td1 typ.=70ns & max=150ns; tf typ.=25ns & max= 50ns; VOH max.=1.4V; added note on IO+/- as guaranteed by design, added Input/Output Pin Equivalent Circuit Diagrams, added Important Notice, added ESD level in Qual Info Page, modified disclaimer under Absolute Max. Ratings; modified conditions under Dynamic Elec. Char.;
01/12/2010	Added parameter vs. temperature graphs; removed Preliminary; removed Latch Up rating in qualification info page
01/13/2010	Added passing voltage level for ESD on Qual Info Page.
01/31/2010	Removed passing voltage level for ESD on Qual Info Page.
03/12/2010	Front page: added unit (A) to IO+ & (ns) for ton; add "direct fuel injection" to application list. Page3: changed from Vcc to Vs in diagram, removed "cross-conduction" from description statement. Updated Parameter Trends vs temp statement with "supply voltage of 15V".
03/15/2010	Page 8: changed from Vcc to Vs in schematics; put back "driver cross-conduction" in description statement.
03/19/2010	Corrected Tf spec. typ=15nS, max=50nS.
07/30/2010	Part number changed to 44261; Min Vs=4.8V; Input thresholds spec changed into values proportional to Vs; Iqbmax consumption increased from 200uA to 220uA ; I <sub>IN+</sub> increased to 15Vtyp and 25Vmax; I <sub>IN-</sub> changed to 0uA <sub>typ</sub> , 1uA <sub>max</sub> ; input pullup resistor connected to Vs.
10/21/2010	Test condition corrected for Io- (Vo=4.8V instead of 15V) and for V <sub>OH</sub> and V <sub>OL</sub> (I=2mA instead of 20mA).
11/18/2010	AUIR4426 name corrected in AUIR44261 page2 and header
01/17/2011	Table with Vs=4.8V: VOH max limit changed to 1.9V; Tr to 65ns and td2 to 220ns
02/22/2011	Removed tri-temp graphs
03/02/2011	Inserted tri-temp graphs, based on 3 sigma and Vs = 4.8V & 15V
03/04/2011	Added "Preliminary Data Sheet" in front page titles.
5/17/2011	Updated tri-temp graphs, important notice. Change Iqs_15V typ. To 70; Voh(4.8) max to 2.2; Tr, Tf (4.8) max to 75; Ton(4.8) max to 220; Toff(4.8) max to 250.
5/30/2011	VIH and VIL parameter exchange; VOH specified at cold and at hot.
6/30/11	Updated part marking & world headquarters address

## Looking for pricing, stock, or lifecycle information?

Click below to explore more details on WIN SOURCE:

 [View AUIRS44261S on WIN SOURCE](#)

 [Infineon Technologies](#) Information

## Optimize Your Supply Chain with WIN SOURCE Solutions

-  Global Sourcing Solution
-  Obsolete Management
-  Cost Control Management
-  Shortage Management
-  Alternative Solution
-  Excess Inventory Management