



**THE DATASHEET OF
SN74LV374ANSR**



SNx4LV374A Octal Edge-Triggered D-Type Flip-Flops With 3-State Outputs

1 Features

- 2-V to 5.5-V V_{CC} Operation
- Maximum t_{pd} of 9.5 ns at 5 V
- Typical V_{OLP} (Output Ground Bounce) <0.8 V at $V_{CC} = 3.3$ V, $T_A = 25^\circ\text{C}$
- Typical V_{OHV} (Output V_{OH} Undershoot) >2.3 V at $V_{CC} = 3.3$ V, $T_A = 25^\circ\text{C}$
- Support Mixed-Mode Voltage Operation on All Ports
- I_{off} Supports Partial-Power-Down Mode Operation
- Latch-up Performance Exceeds 250 mA Per JESD 17
- ESD Protection Exceeds JESD 22
 - 2000-V Human-Body Model (A114-A)
 - 200-V Machine Model (A115-A)
 - 1000-V Charged-Device Model (C101)

2 Applications

- Programmable Logic Controller (PLC)
- DCS and PAC: Analog Input Module
- Trains, Trams, and Subway Carriages
- AC Inverter Drives
- Printers

3 Description

The SNx4LV374A devices are octal edge-triggered D-type flip-flops designed for 2-V to 5.5-V V_{CC} operation.

Device Information⁽¹⁾

PART NUMBER	PACKAGE	BODY SIZE (NOM)
SN74LV374ADB	SSOP (20)	7.20 mm × 5.30 mm
SN74LV374ADW	SOIC (20)	12.80 mm × 7.50 mm
SN74LV374ANS	SO (20)	12.60 mm × 5.30 mm
SN74LV374APW	TSSOP (20)	6.50 mm × 4.40 mm

(1) For all available packages, see the orderable addendum at the end of the data sheet.

Logic Diagram (Positive Logic)

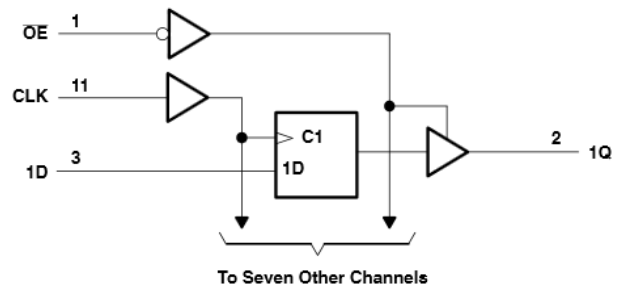

Pin numbers shown are for the DB, DW, FK, J, NS, PW, RGY, and W packages.



Table of Contents

1	Features	1	8.1	Overview	10
2	Applications	1	8.2	Functional Block Diagram	10
3	Description	1	8.3	Feature Description	10
4	Revision History	2	8.4	Device Functional Modes	10
5	Pin Configuration and Functions	3	9	Application and Implementation	11
6	Specifications	4	9.1	Application Information	11
6.1	Absolute Maximum Ratings	4	9.2	Typical Application	11
6.2	ESD Ratings	4	10	Power Supply Recommendations	13
6.3	Recommended Operating Conditions	5	11	Layout	13
6.4	Thermal Information	5	11.1	Layout Guidelines	13
6.5	Electrical Characteristics	6	11.2	Layout Example	13
6.6	Switching Characteristics: $V_{CC} = 2.5\text{ V} \pm 0.2\text{ V}$	6	12	Device and Documentation Support	14
6.7	Switching Characteristics: $V_{CC} = 3.3\text{ V} \pm 0.3\text{ V}$	7	12.1	Documentation Support	14
6.8	Switching Characteristics: $V_{CC} = 5\text{ V} \pm 0.5\text{ V}$	7	12.2	Related Links	14
6.9	Timing Requirements	7	12.3	Receiving Notification of Documentation Updates	14
6.10	Noise Characteristics	8	12.4	Community Resources	14
6.11	Operating Characteristics, $T_A = 25^\circ\text{C}$	8	12.5	Trademarks	14
6.12	Typical Characteristics	8	12.6	Electrostatic Discharge Caution	14
7	Parameter Measurement Information	9	12.7	Glossary	14
8	Detailed Description	10	13	Mechanical, Packaging, and Orderable Information	14

4 Revision History

NOTE: Page numbers for previous revisions may differ from page numbers in the current version.

Changes from Revision I (March 2015) to Revision J

Page

• Added Junction temperature, T_J	4
• Deleted " $V_{CC} \times 0.3$ " from MIN and added " $V_{CC} \times 0.3$ " to MAX for SN54LV374A and SN74LV374A	5
• Changed "SN54LV384A" to "SN54LV374A" in <i>Electrical Characteristics</i> table	6
• Added <i>Related Links</i> section, <i>Receiving Notification of Documentation Updates</i> section, and <i>Community Resources</i> section	14

Changes from Revision H (April 2005) to Revision I

Page

• Added <i>Pin Configuration and Functions</i> section, <i>ESD Ratings</i> table, <i>Feature Description</i> section, <i>Device Functional Modes</i> , <i>Application and Implementation</i> section, <i>Power Supply Recommendations</i> section, <i>Layout</i> section, <i>Device and Documentation Support</i> section, and <i>Mechanical, Packaging, and Orderable Information</i> section	1
--	----------

5 Pin Configuration and Functions

DB, DW, NS, or PW Package
20-PIN SSOP, SOIC, SO, or TSSOP
Top View

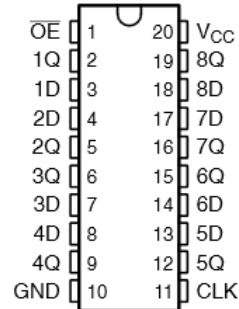

Pin Functions

PIN		I/O	DESCRIPTION
NO.	NAME		
1	\overline{OE}	I	Enable pin
2	1Q	O	Output 1
3	1D	I	Input 1
4	2D	I	Input 2
5	2Q	O	Output 2
6	3Q	O	Output 3
7	3D	I	Input 3
8	4D	I	Input 4
9	4Q	O	Output 4
10	GND	–	Ground pin
11	CLK	I	Clock pin
12	5Q	O	Output 5
13	5D	I	Input 5
14	6D	I	Input 6
15	6Q	O	Output 6
16	7Q	O	Output 7
17	7D	I	Input 7
18	8D	I	Input 8
19	8Q	O	Output 8
20	V _{CC}	–	Power pin

6 Specifications

6.1 Absolute Maximum Ratings

over operating free-air temperature range (unless otherwise noted) ⁽¹⁾

		MIN	MAX	UNIT
V_{CC}	Supply voltage	-0.5	7	V
V_I	Input voltage ⁽²⁾	-0.5	7	V
V_O	Voltage applied to any output in the high-impedance or power-off state ⁽²⁾	-0.5	7	V
V_O	Output voltage ⁽²⁾⁽³⁾	-0.5	$V_{CC} + 0.5$	V
I_{IK}	Input clamp current, ($V_I < 0$)		-20	mA
I_{OK}	Output clamp current, ($V_O < 0$)		-50	mA
I_O	Continuous output current, ($V_O = 0$ to V_{CC})		± 35	mA
	Continuous current through V_{CC} or GND		± 70	mA
T_J	Junction temperature		150	°C
T_{stg}	Storage temperature	-65	150	°C

(1) Stresses beyond those listed under *Absolute Maximum Ratings* may cause permanent damage to the device. These are stress ratings only, which do not imply functional operation of the device at these or any other conditions beyond those indicated under *Recommended Operating Conditions*. Exposure to absolute-maximum-rated conditions for extended periods may affect device reliability.

(2) The input and output negative-voltage ratings may be exceeded if the input and output current ratings are observed.

(3) This value is limited to 5.5 V maximum.

6.2 ESD Ratings

		VALUE	UNIT
$V_{(ESD)}$	Electrostatic discharge	Human body model (HBM), per ANSI/ESDA/JEDEC JS-001 ⁽¹⁾	2000
		Charged-device model (CDM), per JEDEC specification JESD22-C101 ⁽²⁾	1000

(1) JEDEC document JEP155 states that 500-V HBM allows safe manufacturing with a standard ESD control process.

(2) JEDEC document JEP157 states that 250-V CDM allows safe manufacturing with a standard ESD control process.

6.3 Recommended Operating Conditions

 over operating free-air temperature range (unless otherwise noted) ⁽¹⁾

		SN54LV374A ⁽²⁾		SN74LV374A		UNIT	
		MIN	MAX	MIN	MAX		
V _{CC}	Supply voltage	2	5.5	2	5.5	V	
V _{IH}	High-level input voltage	V _{CC} = 2 V	1.5	1.5		V	
		V _{CC} = 2.3 V to 2.7 V	V _{CC} × 0.7	V _{CC} × 0.7			
		V _{CC} = 3 V to 3.6 V	V _{CC} × 0.7	V _{CC} × 0.7			
		V _{CC} = 4.5 V to 5.5 V	V _{CC} × 0.7	V _{CC} × 0.77			
V _{IL}	Low-level input voltage	V _{CC} = 2 V		0.5	0.5	V	
		V _{CC} = 2.3 V to 2.7 V		V _{CC} × 0.3	V _{CC} × 0.3		
		V _{CC} = 3 V to 3.6 V		V _{CC} × 0.3	V _{CC} × 0.3		
		V _{CC} = 4.5 V to 5.5 V		V _{CC} × 0.3	V _{CC} × 0.3		
V _I	Input voltage	0	5.5	0	5.5	V	
V _O	Output voltage	High or low state	0	V _{CC}	0	V _{CC}	V
		3-state	0	5.5	0	5.5	
I _{OH}	High-level output current	V _{CC} = 2 V		-50	-50	μA	
		V _{CC} = 2.3 V to 2.7 V		-2	-2	mA	
		V _{CC} = 3 V to 3.6 V		-8	-8		
		V _{CC} = 4.5 V to 5.5 V		-16	-16		
I _{OL}	Low-level output current	V _{CC} = 2 V		50	50	μA	
		V _{CC} = 2.3 V to 2.7 V		2	2	mA	
		V _{CC} = 3 V to 3.6 V		8	8		
		V _{CC} = 4.5 V to 5.5 V		16	16		
Δt/Δv	Input transition rise or fall rate	V _{CC} = 2.3 V to 2.7 V		200	200	ns/V	
		V _{CC} = 3 V to 3.6 V		100	100		
		V _{CC} = 4.5 V to 5.5 V		20	20		
T _A	Operating free-air temperature	-55	125	-40	125	°C	

(1) All unused inputs of the device must be held at V_{CC} or GND to ensure proper device operation. See [Implications of Slow or Floating CMOS Inputs](#), SCBA004.

(2) PRODUCT PREVIEW

6.4 Thermal Information

THERMAL METRIC ⁽¹⁾		SN74LV374A				UNIT
		DB (SSOP)	DW (SOIC)	NS (SO)	PW (TSSOP)	
		20 PINS	20 PINS	20 PINS	20 PINS	
R _{θJA}	Junction-to-ambient thermal resistance	94.5	79.2	76.7	102.4	°C/W
R _{θJC(top)}	Junction-to-case (top) thermal resistance	56.4	43.7	43.2	36.5	°C/W
R _{θJB}	Junction-to-board thermal resistance	49.7	47	44.2	53.6	°C/W
ψ _{JT}	Junction-to-top characterization parameter	18.5	18.6	16.8	2.4	°C/W
ψ _{JB}	Junction-to-board characterization parameter	49.3	46.5	43.8	52.9	°C/W

(1) For more information about traditional and new thermal metrics, see the [Semiconductor and IC Package Thermal Metrics](#) application report.

6.5 Electrical Characteristics

over recommended operating free-air temperature range (unless otherwise noted)

PARAMETER	TEST CONDITIONS	V _{CC}	SN54LV374A ⁽¹⁾			SN74LV374A –40°C to +85°C			SN74LV374A –40°C to +125°C			UNIT
			MIN	TYP	MAX	MIN	TYP	MAX	MIN	TYP	MAX	
V _{OH}	I _{OH} = –50 μA	2 V to 5.5 V	V _{CC} –0.1			V _{CC} –0.1			V _{CC} –0.1			V
	I _{OH} = –2 mA	2.3 V	2			2			2			
	I _{OH} = –8 mA	3 V	2.48			2.48			2.48			
	I _{OH} = –16 mA	4.5 V	3.8			3.8			3.8			
V _{OL}	I _{OL} = 50 μA	2 V to 5.5 V	0.1			0.1			0.1			V
	I _{OL} = 2 mA	2.3 V	0.4			0.4			0.4			
	I _{OL} = 8 mA	3 V	0.44			0.44			0.44			
	I _{OL} = 16 mA	4.5 V	0.55			0.55			0.55			
I _I	V _I = 5.5 V or GND	0 to 5.5 V	±1			±1			±1			μA
I _{OZ}	V _O = V _{CC} or GND	5.5 V	±5			±5			±5			μA
I _{CC}	V _I = V _{CC} or GND, I _O = 0	5.5 V	20			20			20			μA
I _{off}	V _I or V _O = 0 to 5.5 V	0	5			5			5			μA
C _i	V _I = V _{CC} or GND	3.3 V	2.9			2.9			2.9			pF

(1) PRODUCT PREVIEW

6.6 Switching Characteristics: V_{CC} = 2.5 V ± 0.2 V

 over recommended operating free-air temperature range, V_{CC} = 2.5 V ± 0.2 V (unless otherwise noted)

PARAMETER	FROM (INPUT)	TO (OUTPUT)	LOAD CAPACITANCE	T _A = 25°C			SN54LV374A		SN74LV374A –40°C to +85°C		SN74LV374A –40°C to +125°C		UNIT
				MIN	TYP	MAX	MIN	MAX	MIN	MAX	MIN	MAX	
f _{max}			C _L = 15 pF	60 ⁽¹⁾	105 ⁽¹⁾		50 ⁽¹⁾		50		50	MHz	
			C _L = 50 pF	50	85		40		40		40		
t _{pd}	CLK	Q	C _L = 15 pF	9.7 ⁽¹⁾	16.3 ⁽¹⁾		1 ⁽¹⁾	19 ⁽¹⁾	1	19	1	20.5	ns
t _{en}	\overline{OE}	Q		8.9 ⁽¹⁾	15.9 ⁽¹⁾		1 ⁽¹⁾	19 ⁽¹⁾	1	19	1	20.5	
t _{dis}	\overline{OE}	Q		6.3 ⁽¹⁾	12.6 ⁽¹⁾		1 ⁽¹⁾	15 ⁽¹⁾	1	15	1	16.5	
t _{pd}	CLK	Q	C _L = 50 pF	11.8	19.3		1	23	1	23	1	24.5	ns
t _{en}	\overline{OE}	Q		10.9	18.8		1	22	1	22	1	23.5	
t _{dis}	\overline{OE}	Q		8.2	17.3		1	19	1	19	1	20.5	
t _{sk(o)}						2				2			

(1) On products compliant to MIL-PRF-38535, this parameter is not production tested.

6.7 Switching Characteristics: $V_{CC} = 3.3\text{ V} \pm 0.3\text{ V}$

 over recommended operating free-air temperature range, $V_{CC} = 3.3\text{ V} \pm 0.3\text{ V}$ (unless otherwise noted)

PARAMETER	FROM (INPUT)	TO (OUTPUT)	LOAD CAPACITANCE	$T_A = 25^\circ\text{C}$			SN54LV374A		SN74LV374A –40°C to +85°C		SN74LV374A –40°C to +125°C		UNIT
				MIN	TYP	MAX	MIN	MAX	MIN	MAX	MIN	MAX	
f_{max}			$C_L = 15\text{ pF}$	80 ⁽¹⁾	150 ⁽¹⁾		70 ⁽¹⁾		70		70	MHz	
			$C_L = 50\text{ pF}$	55	110		50		50		50		
t_{pd}	CLK	Q	$C_L = 15\text{ pF}$		6.8 ⁽¹⁾	12.7 ⁽¹⁾	1 ⁽¹⁾	15 ⁽¹⁾	1	15	1	16	ns
t_{en}	\overline{OE}	Q			6.3 ⁽¹⁾	11 ⁽¹⁾	1 ⁽¹⁾	13 ⁽¹⁾	1	13	1	14	
t_{dis}	\overline{OE}	Q			4.7 ⁽¹⁾	10.5 ⁽¹⁾	1 ⁽¹⁾	12.5 ⁽¹⁾	1	12.5	1	13.5	
t_{pd}	CLK	Q	$C_L = 50\text{ pF}$		8.3	16.2	1	18.5	1	18.5	1	19.5	ns
t_{en}	\overline{OE}	Q			7.7	14.5	1	16.5	1	16.5	1	17.5	
t_{dis}	\overline{OE}	Q			5.9	14	1	16	1	16	1	17	
$t_{sk(o)}$						1.5				1.5			

(1) On products compliant to MIL-PRF-38535, this parameter is not production tested.

6.8 Switching Characteristics: $V_{CC} = 5\text{ V} \pm 0.5\text{ V}$

 over recommended operating free-air temperature range, $V_{CC} = 5\text{ V} \pm 0.5\text{ V}$ (unless otherwise noted)

PARAMETER	FROM (INPUT)	TO (OUTPUT)	LOAD CAPACITANCE	$T_A = 25^\circ\text{C}$			SN54LV374A		SN74LV374A –40°C to +85°C		SN74LV374A –40°C to +125°C		UNIT
				MIN	TYP	MAX	MIN	MAX	MIN	MAX	MIN	MAX	
f_{max}			$C_L = 15\text{ pF}$	130 ⁽¹⁾	205 ⁽¹⁾		110 ⁽¹⁾		110		110	MHz	
			$C_L = 50\text{ pF}$	85	1705		75		75		75		
t_{pd}	CLK	Q	$C_L = 15\text{ pF}$		4.9 ⁽¹⁾	8.1 ⁽¹⁾	1 ⁽¹⁾	9.5 ⁽¹⁾	1	9.5	1	10.5	ns
t_{en}	\overline{OE}	Q			4.6 ⁽¹⁾	7.6 ⁽¹⁾	1 ⁽¹⁾	9 ⁽¹⁾	1	9	1	10	
t_{dis}	\overline{OE}	Q			3.4 ⁽¹⁾	6.8 ⁽¹⁾	1 ⁽¹⁾	8 ⁽¹⁾	1	8	1	9	
t_{pd}	CLK	Q	$C_L = 50\text{ pF}$		5.9	10.1	1	11.5	1	11.5	1	12.5	ns
t_{en}	\overline{OE}	Q			5.5	9.6	1	11	1	11	1	12	
t_{dis}	\overline{OE}	Q			4	8.8	1	10	1	10	1	11	
$t_{sk(o)}$						1				1			

(1) On products compliant to MIL-PRF-38535, this parameter is not production tested.

6.9 Timing Requirements

 over recommended operating free-air temperature range, (unless otherwise noted) (see [Figure 3](#))

		$T_A = 25^\circ\text{C}$		SN54LV374A ⁽¹⁾		SN74LV374A –40°C to +85°C		SN74LV374A –40°C to +125°C		UNIT
		MIN	MAX	MIN	MAX	MIN	MAX	MIN	MAX	
$V_{CC} = 2.5\text{ V} \pm 0.2\text{ V}$										
t_w	Pulse duration, CLK high or low	6		7		7		7		ns
t_{su}	Setup time, data before CLK \uparrow	5		5.5		5.5		6		ns
t_h	Hold time, data after CLK \uparrow	2.5		2.5		2.5		3		ns
$V_{CC} = 3.3\text{ V} \pm 0.3\text{ V}$										
t_w	Pulse duration, CLK high or low	5		5.5		5.5		5.5		ns
t_{su}	Setup time, data before CLK \uparrow	4.5		4.5		4.5		5		ns
t_h	Hold time, data after CLK \uparrow	2		2		2		2.5		ns
$V_{CC} = 5\text{ V} \pm 0.5\text{ V}$										
t_w	Pulse duration, CLK high or low	5		5		5		5		ns
t_{su}	Setup time, data before CLK \uparrow	3		3		3		3.5		ns
t_h	Hold time, data after CLK \uparrow	2		2		2		2.5		ns

(1) PRODUCT PREVIEW

6.10 Noise Characteristics

 $V_{CC} = 3.3\text{ V}$, $C_L = 50\text{ pF}$, $T_A = 25^\circ\text{C}$ ⁽¹⁾

PARAMETER	SN74LV374A			UNIT
	MIN	TYP	MAX	
$V_{OL(P)}$ Quiet output, maximum dynamic V_{OL}		0.6	0.8	V
$V_{OL(V)}$ Quiet output, minimum dynamic V_{OL}		-0.5	-0.8	V
$V_{OH(V)}$ Quiet output, minimum dynamic V_{OH}	2.9	2.9		V
$V_{IH(D)}$ High-level dynamic input voltage	2.31			V
$V_{IL(D)}$ Low-level dynamic input voltage			0.99	V

(1) Characteristics are for surface-mount packages only.

6.11 Operating Characteristics, $T_A = 25^\circ\text{C}$

PARAMETER		TEST CONDITIONS	V_{CC}	TYP	UNIT
C_{pd} Power dissipation capacitance	Outputs enabled	$C_L = 50\text{ pF}$, $f = 10\text{ MHz}$	3.3 V	21.1	pF
			5 V	22.8	

6.12 Typical Characteristics

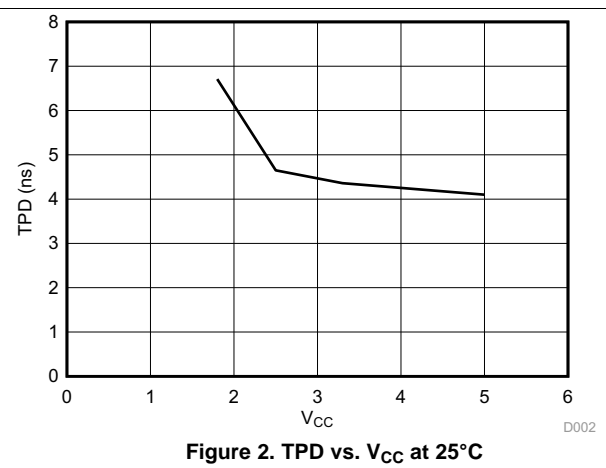
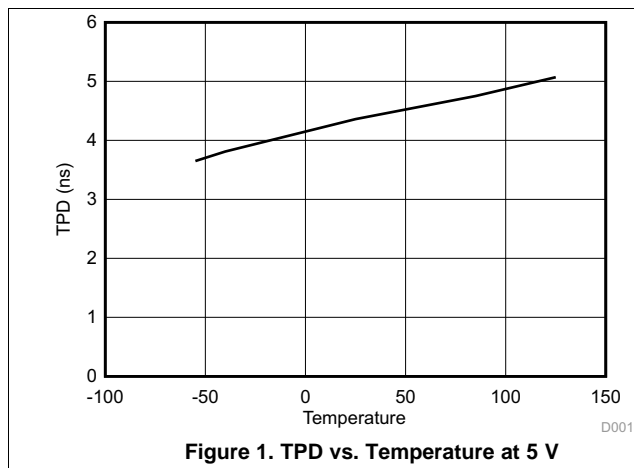

7 Parameter Measurement Information

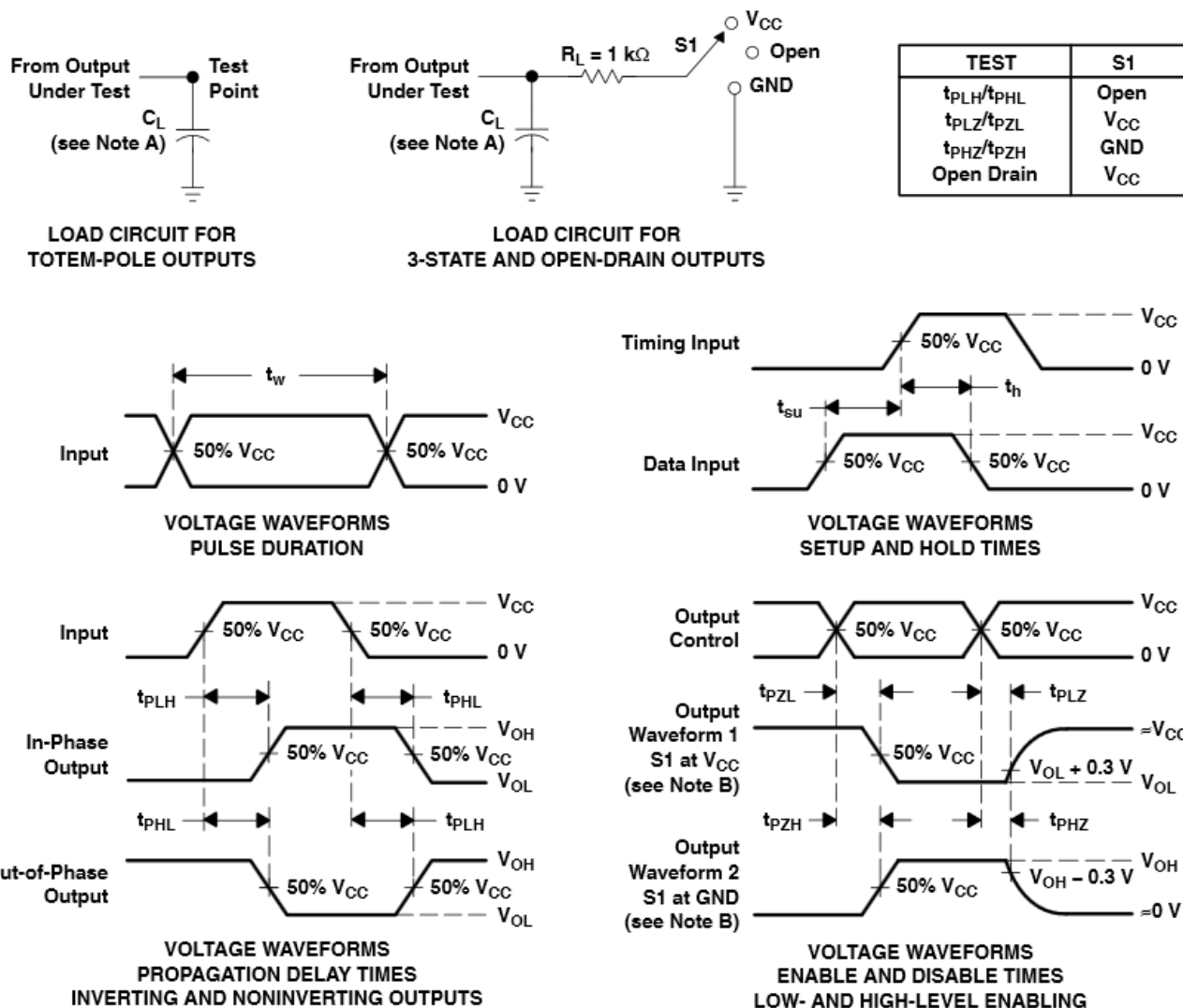

- NOTES:
- A. C_L includes probe and jig capacitance.
 - B. Waveform 1 is for an output with internal conditions such that the output is low, except when disabled by the output control. Waveform 2 is for an output with internal conditions such that the output is high, except when disabled by the output control.
 - C. All input pulses are supplied by generators having the following characteristics: PRR $\leq 1\text{ MHz}$, $Z_O = 50\ \Omega$, $t_r \leq 3\text{ ns}$, $t_f \leq 3\text{ ns}$.
 - D. The outputs are measured one at a time, with one input transition per measurement.
 - E. t_{PLZ} and t_{PHZ} are the same as t_{dis} .
 - F. t_{PZL} and t_{PZH} are the same as t_{en} .
 - G. t_{PHL} and t_{PLH} are the same as t_{pd} .
 - H. All parameters and waveforms are not applicable to all devices.

Figure 3. Load Circuit and Voltage Waveforms

8 Detailed Description

8.1 Overview

The SNx4LV374A devices are octal edge-triggered D-type flip-flops designed for 2-V to 5.5-V V_{CC} operation. These devices feature 3-state outputs designed specifically for driving highly capacitive or relatively low-impedance loads. They are particularly suitable for implementing buffer registers, I/O ports, bi-directional bus drivers, and working registers. On the positive transition of the clock (CLK) input, the Q outputs are set to the logic levels set up at the data (D) inputs. A buffered output-enable (\overline{OE}) input can be used to place the eight outputs in either a normal logic state (high or low logic levels) or high-impedance state. In the high-impedance state, the outputs neither load nor drive the bus lines significantly. The high-impedance state and the increased drive provide the capability to drive bus lines without need for interface or pullup components. \overline{OE} does not affect internal operations of the latch. Old data can be retained or new data can be entered while the outputs are in the high-impedance state. To ensure the high-impedance state during power up or power down, \overline{OE} should be tied to V_{CC} through a pullup resistor; the minimum value of the resistor is determined by the current-sinking capability of the driver. These devices are fully specified for partial-power-down applications using Ioff. The Ioff circuitry disables the outputs, preventing damaging current backflow through the devices when they are powered down. The output of the device is unknown until the first valid rising clock edge occurs while V_{CC} is within the [Recommended Operating Conditions](#) range.

8.2 Functional Block Diagram

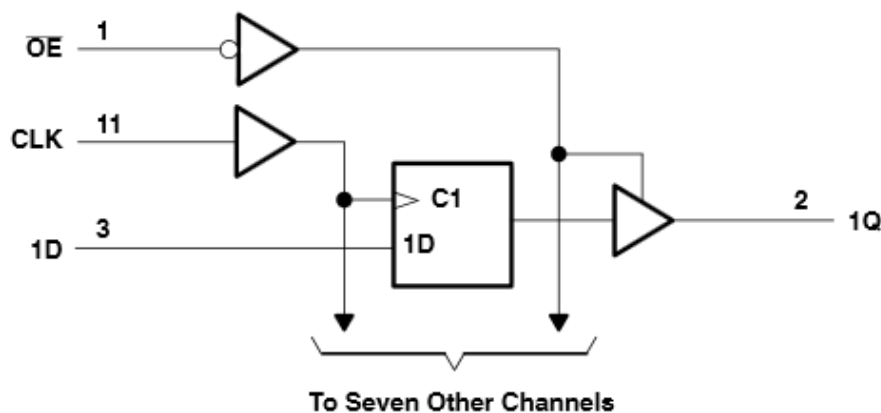

Figure 4. Logic Diagram (Positive Logic)

8.3 Feature Description

The device's wide operating range allows it to be used in a variety of systems that use different logic levels. The low propagation delay allows fast switching and higher speeds of operation. In addition, the low ground bounce stabilizes the performance of non-switching outputs while another output is switching.

8.4 Device Functional Modes

Table 1 lists the functional modes of the SNx4LV374A devices.

Table 1. Function Table (Each Flip-Flop)

INPUTS			OUTPUT Q
\overline{OE}	CLK	D	
L	↑	H	H
L	↑	L	L
L	L	X	Q_0
H	X	X	Z

9 Application and Implementation

NOTE

Information in the following applications sections is not part of the TI component specification, and TI does not warrant its accuracy or completeness. TI's customers are responsible for determining suitability of components for their purposes. Customers should validate and test their design implementation to confirm system functionality.

9.1 Application Information

The SN74LV374A is a low drive CMOS device that can be used for a multitude of bus interface type applications where output ringing is a concern. The low drive and slow edge rates will minimize overshoot and undershoot on the outputs. The inputs accept voltages up to 5.5 V allowing down translation to the V_{CC} level.

9.2 Typical Application

Figure 5 shows how the slower edges can reduce ringing on the output compared to higher drive parts like AC.

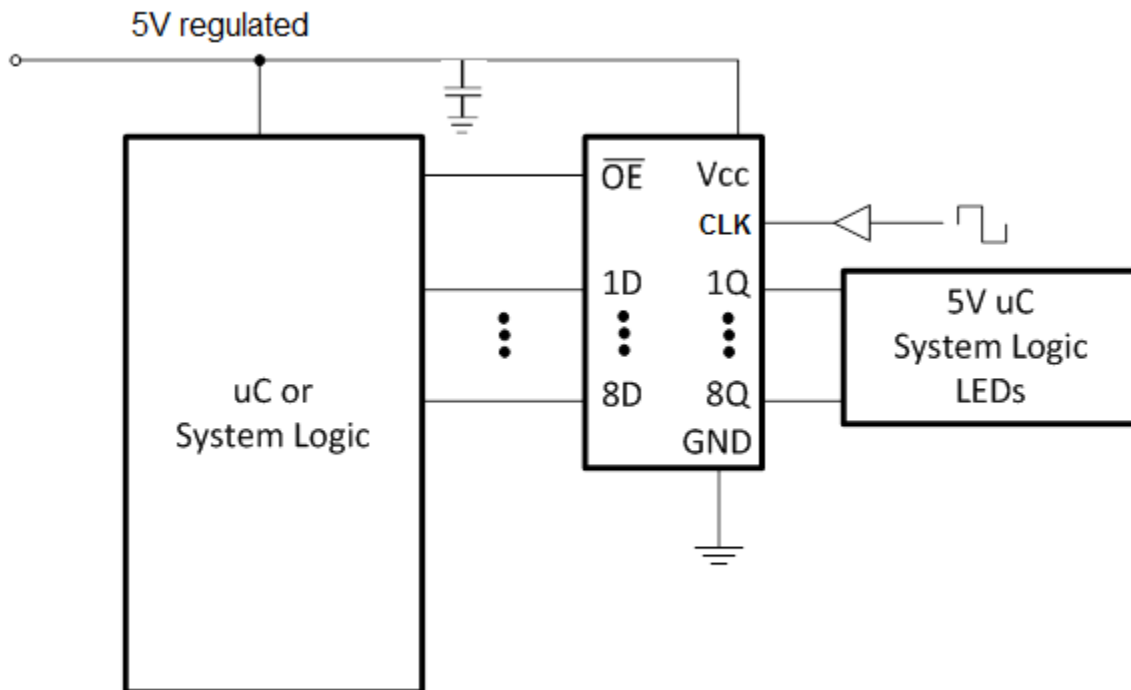

Figure 5. Typical Application Schematic

9.2.1 Design Requirements

This device uses CMOS technology and has balanced output drive. Take care to avoid bus contention because it can drive currents that would exceed maximum limits. The high drive will also create fast edges into light loads so consider routing and load conditions to prevent ringing.

Typical Application (continued)

9.2.2 Detailed Design Procedure

- Recommended Input conditions:
 - Rise time and fall time specs see $(\Delta t/\Delta V)$ in [Recommended Operating Conditions](#).
 - Specified High and low levels. See $(V_{IH}$ and $V_{IL})$ in [Recommended Operating Conditions](#).
 - Inputs are overvoltage tolerant allowing them to go as high as 5.5 V at any valid V_{CC} .
- Recommended output conditions:
 - Load currents should not exceed 35 mA per output and 70 mA total for the part.
 - Outputs should not be pulled above V_{CC} .

9.2.3 Application Curve

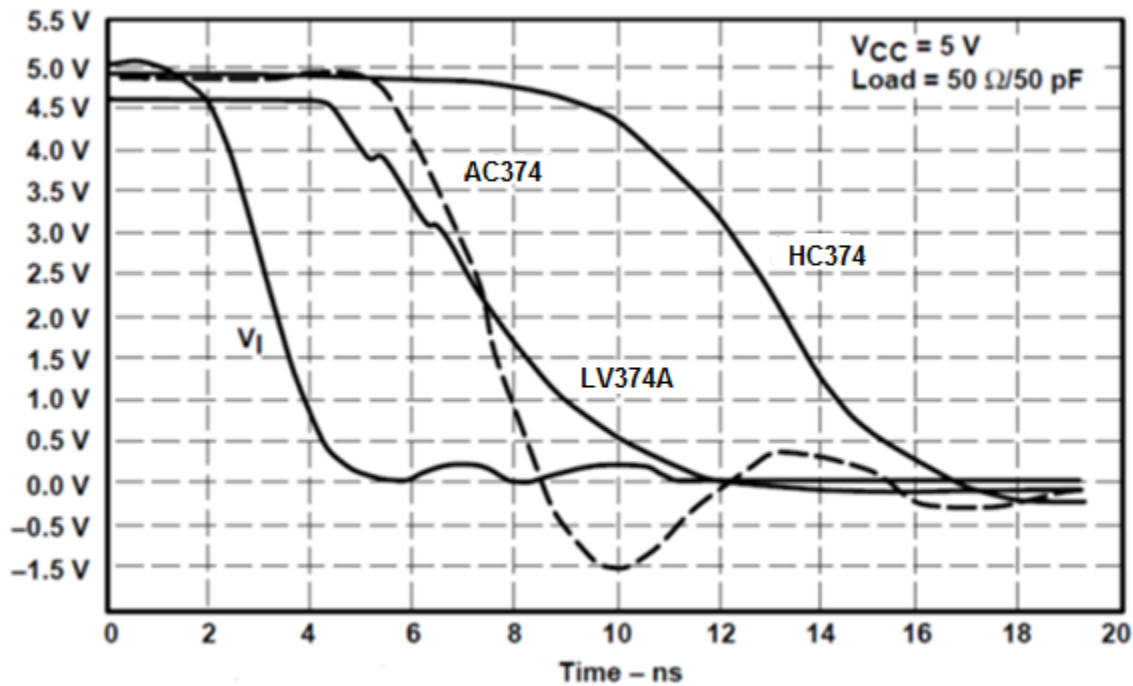

Figure 6. Switching Characteristics Comparison

10 Power Supply Recommendations

The power supply can be any voltage between the MIN and MAX supply voltage rating located in the [Recommended Operating Conditions](#). Each V_{CC} terminal should have a good bypass capacitor to prevent power disturbance. For devices with a single supply, TI recommends a 0.1- μF capacitor and if there are multiple V_{CC} terminals then TI recommends a 0.01- μF or 0.022- μF capacitor for each power terminal. Multiple bypass capacitors can be paralleled to reject different frequencies of noise. Frequencies of 0.1 μF and 1 μF are commonly used in parallel. The bypass capacitor should be installed as close as possible to the power terminal for best results.

11 Layout

11.1 Layout Guidelines

When using multiple bit logic devices inputs should not ever float. In many cases, functions or parts of functions of digital logic devices are unused, for example, when only two inputs of a triple-input AND gate are used or only three of the four buffer gates are used. Such input pins should not be left unconnected because the undefined voltages at the outside connections result in undefined operational states. Specified below are the rules that must be observed under all circumstances. All unused inputs of digital logic devices must be connected to a high or low bias to prevent them from floating. The logic level that should be applied to any particular unused input depends on the function of the device. Generally they will be tied to GND or V_{CC} whichever make more sense or is more convenient. Floating outputs is generally acceptable, unless the part is a transceiver. If the transceiver has an output enable pin it will disable the outputs section of the part when asserted. This will not disable the input section of the I.O's so they also cannot float when disabled.

11.2 Layout Example

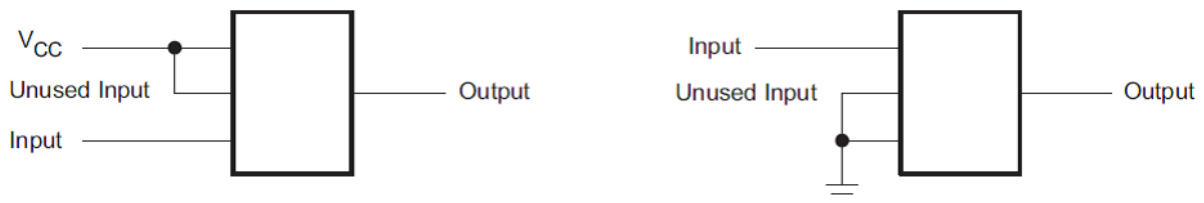

Figure 7. Layout Example

12 Device and Documentation Support

12.1 Documentation Support

12.1.1 Related Documentation

For related documentation see the following:

[Implications of Slow or Floating CMOS Inputs](#), SCBA004

12.2 Related Links

The table below lists quick access links. Categories include technical documents, support and community resources, tools and software, and quick access to sample or buy.

Table 2. Related Links

PARTS	PRODUCT FOLDER	SAMPLE & BUY	TECHNICAL DOCUMENTS	TOOLS & SOFTWARE	SUPPORT & COMMUNITY
SN54LV374A	Click here	Click here	Click here	Click here	Click here
SN74LV374A	Click here	Click here	Click here	Click here	Click here

12.3 Receiving Notification of Documentation Updates

To receive notification of documentation updates, navigate to the device product folder on ti.com. In the upper right corner, click on *Alert me* to register and receive a weekly digest of any product information that has changed. For change details, review the revision history included in any revised document.

12.4 Community Resources

The following links connect to TI community resources. Linked contents are provided "AS IS" by the respective contributors. They do not constitute TI specifications and do not necessarily reflect TI's views; see TI's [Terms of Use](#).

TI E2E™ Online Community *TI's Engineer-to-Engineer (E2E) Community*. Created to foster collaboration among engineers. At e2e.ti.com, you can ask questions, share knowledge, explore ideas and help solve problems with fellow engineers.

Design Support *TI's Design Support* Quickly find helpful E2E forums along with design support tools and contact information for technical support.

12.5 Trademarks

E2E is a trademark of Texas Instruments. All other trademarks are the property of their respective owners.

12.6 Electrostatic Discharge Caution



These devices have limited built-in ESD protection. The leads should be shorted together or the device placed in conductive foam during storage or handling to prevent electrostatic damage to the MOS gates.

12.7 Glossary

[SLYZ022](#) — *TI Glossary*.

This glossary lists and explains terms, acronyms, and definitions.

13 Mechanical, Packaging, and Orderable Information

The following pages include mechanical, packaging, and orderable information. This information is the most current data available for the designated devices. This data is subject to change without notice and revision of this document. For browser-based versions of this data sheet, refer to the left-hand navigation.

PACKAGING INFORMATION

Orderable Device	Status (1)	Package Type	Package Drawing	Pins	Package Qty	Eco Plan (2)	Lead/Ball Finish (6)	MSL Peak Temp (3)	Op Temp (°C)	Device Marking (4/5)	Samples
SN74LV374ADBR	ACTIVE	SSOP	DB	20	2000	Green (RoHS & no Sb/Br)	CU NIPDAU	Level-1-260C-UNLIM	-40 to 125	LV374A	Samples
SN74LV374ADW	ACTIVE	SOIC	DW	20	25	Green (RoHS & no Sb/Br)	CU NIPDAU	Level-1-260C-UNLIM	-40 to 125	LV374A	Samples
SN74LV374ADWG4	ACTIVE	SOIC	DW	20	25	Green (RoHS & no Sb/Br)	CU NIPDAU	Level-1-260C-UNLIM	-40 to 125	LV374A	Samples
SN74LV374ADWR	ACTIVE	SOIC	DW	20	2000	Green (RoHS & no Sb/Br)	CU NIPDAU	Level-1-260C-UNLIM	-40 to 125	LV374A	Samples
SN74LV374ANSR	ACTIVE	SO	NS	20	2000	Green (RoHS & no Sb/Br)	CU NIPDAU	Level-1-260C-UNLIM	-40 to 125	74LV374A	Samples
SN74LV374APW	ACTIVE	TSSOP	PW	20	70	Green (RoHS & no Sb/Br)	CU NIPDAU	Level-1-260C-UNLIM	-40 to 125	LV374A	Samples
SN74LV374APWE4	ACTIVE	TSSOP	PW	20	70	Green (RoHS & no Sb/Br)	CU NIPDAU	Level-1-260C-UNLIM	-40 to 125	LV374A	Samples
SN74LV374APWR	ACTIVE	TSSOP	PW	20	2000	Green (RoHS & no Sb/Br)	CU NIPDAU	Level-1-260C-UNLIM	-40 to 125	LV374A	Samples

(1) The marketing status values are defined as follows:

ACTIVE: Product device recommended for new designs.

LIFEBUY: TI has announced that the device will be discontinued, and a lifetime-buy period is in effect.

NRND: Not recommended for new designs. Device is in production to support existing customers, but TI does not recommend using this part in a new design.

PREVIEW: Device has been announced but is not in production. Samples may or may not be available.

OBSOLETE: TI has discontinued the production of the device.

(2) **RoHS:** TI defines "RoHS" to mean semiconductor products that are compliant with the current EU RoHS requirements for all 10 RoHS substances, including the requirement that RoHS substance do not exceed 0.1% by weight in homogeneous materials. Where designed to be soldered at high temperatures, "RoHS" products are suitable for use in specified lead-free processes. TI may reference these types of products as "Pb-Free".

RoHS Exempt: TI defines "RoHS Exempt" to mean products that contain lead but are compliant with EU RoHS pursuant to a specific EU RoHS exemption.

Green: TI defines "Green" to mean the content of Chlorine (Cl) and Bromine (Br) based flame retardants meet JS709B low halogen requirements of <=100ppm threshold. Antimony trioxide based flame retardants must also meet the <=1000ppm threshold requirement.

(3) MSL, Peak Temp. - The Moisture Sensitivity Level rating according to the JEDEC industry standard classifications, and peak solder temperature.

(4) There may be additional marking, which relates to the logo, the lot trace code information, or the environmental category on the device.

(5) Multiple Device Markings will be inside parentheses. Only one Device Marking contained in parentheses and separated by a "-" will appear on a device. If a line is indented then it is a continuation of the previous line and the two combined represent the entire Device Marking for that device.

(6) Lead/Ball Finish - Orderable Devices may have multiple material finish options. Finish options are separated by a vertical ruled line. Lead/Ball Finish values may wrap to two lines if the finish value exceeds the maximum column width.

Important Information and Disclaimer:The information provided on this page represents TI's knowledge and belief as of the date that it is provided. TI bases its knowledge and belief on information provided by third parties, and makes no representation or warranty as to the accuracy of such information. Efforts are underway to better integrate information from third parties. TI has taken and continues to take reasonable steps to provide representative and accurate information but may not have conducted destructive testing or chemical analysis on incoming materials and chemicals. TI and TI suppliers consider certain information to be proprietary, and thus CAS numbers and other limited information may not be available for release.

In no event shall TI's liability arising out of such information exceed the total purchase price of the TI part(s) at issue in this document sold by TI to Customer on an annual basis.

OTHER QUALIFIED VERSIONS OF SN74LV374A :

- Automotive: [SN74LV374A-Q1](#)

- Enhanced Product: [SN74LV374A-EP](#)

NOTE: Qualified Version Definitions:

- Automotive - Q100 devices qualified for high-reliability automotive applications targeting zero defects

- Enhanced Product - Supports Defense, Aerospace and Medical Applications

TAPE AND REEL INFORMATION



QUADRANT ASSIGNMENTS FOR PIN 1 ORIENTATION IN TAPE



*All dimensions are nominal

Device	Package Type	Package Drawing	Pins	SPQ	Reel Diameter (mm)	Reel Width W1 (mm)	A0 (mm)	B0 (mm)	K0 (mm)	P1 (mm)	W (mm)	Pin1 Quadrant
SN74LV374ADBR	SSOP	DB	20	2000	330.0	16.4	8.2	7.5	2.5	12.0	16.0	Q1
SN74LV374ADWR	SOIC	DW	20	2000	330.0	24.4	10.8	13.3	2.7	12.0	24.0	Q1
SN74LV374ANSR	SO	NS	20	2000	330.0	24.4	8.4	13.0	2.5	12.0	24.0	Q1

TAPE AND REEL BOX DIMENSIONS

*All dimensions are nominal

Device	Package Type	Package Drawing	Pins	SPQ	Length (mm)	Width (mm)	Height (mm)
SN74LV374ADB	SSOP	DB	20	2000	367.0	367.0	38.0
SN74LV374ADWR	SOIC	DW	20	2000	367.0	367.0	45.0
SN74LV374ANSR	SO	NS	20	2000	367.0	367.0	45.0

MECHANICAL DATA

NS (R-PDSO-G**)

PLASTIC SMALL-OUTLINE PACKAGE

14-PINS SHOWN



- NOTES:
- A. All linear dimensions are in millimeters.
 - B. This drawing is subject to change without notice.
 - C. Body dimensions do not include mold flash or protrusion, not to exceed 0,15.

PW (R-PDSO-G20)

PLASTIC SMALL OUTLINE



4040064-5/G 02/11

- NOTES:
- A. All linear dimensions are in millimeters. Dimensioning and tolerancing per ASME Y14.5M-1994.
 - B. This drawing is subject to change without notice.
 -  Body length does not include mold flash, protrusions, or gate burrs. Mold flash, protrusions, or gate burrs shall not exceed 0,15 each side.
 -  Body width does not include interlead flash. Interlead flash shall not exceed 0,25 each side.
 - E. Falls within JEDEC MO-153

PW (R-PDSO-G20)

PLASTIC SMALL OUTLINE



- NOTES:
- A. All linear dimensions are in millimeters.
 - B. This drawing is subject to change without notice.
 - C. Publication IPC-7351 is recommended for alternate design.
 - D. Laser cutting apertures with trapezoidal walls and also rounding corners will offer better paste release. Customers should contact their board assembly site for stencil design recommendations. Refer to IPC-7525 for other stencil recommendations.
 - E. Customers should contact their board fabrication site for solder mask tolerances between and around signal pads.

DB0020A

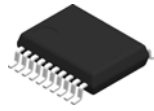

PACKAGE OUTLINE

TSSOP - 2 mm max height

SMALL OUTLINE PACKAGE

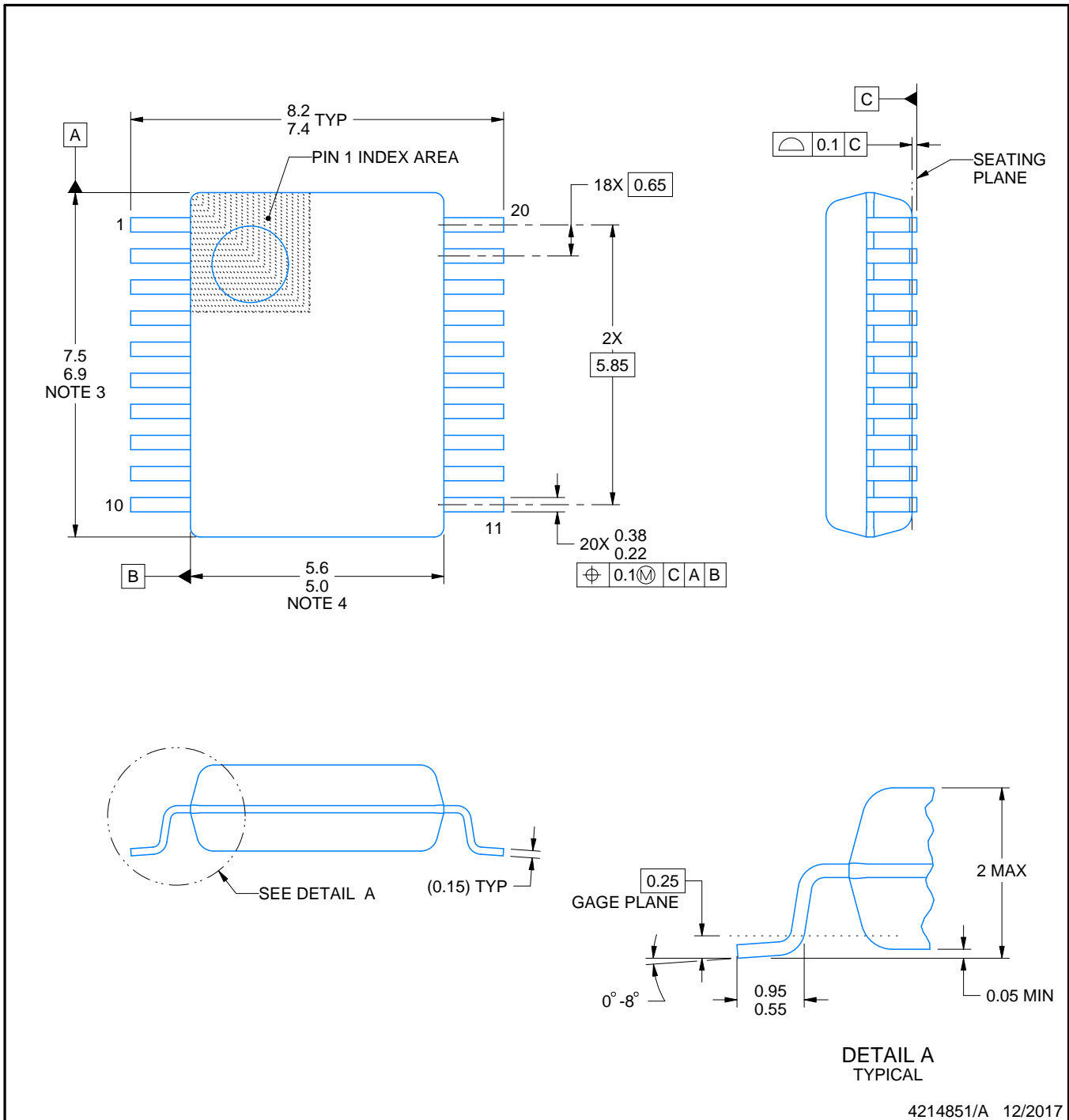

4214851/A 12/2017

NOTES:

- All linear dimensions are in millimeters. Any dimensions in parenthesis are for reference only. Dimensioning and tolerancing per ASME Y14.5M.
- This drawing is subject to change without notice.
- This dimension does not include mold flash, protrusions, or gate burrs. Mold flash, protrusions, or gate burrs shall not exceed 0.15 mm per side.
- This dimension does not include interlead flash. Interlead flash shall not exceed 0.25 mm per side.
- Reference JEDEC registration MO-150.

EXAMPLE BOARD LAYOUT

DB0020A

TSSOP - 2 mm max height

SMALL OUTLINE PACKAGE



LAND PATTERN EXAMPLE
EXPOSED METAL SHOWN
SCALE: 10X



SOLDER MASK DETAILS

4214851/A 12/2017

NOTES: (continued)

- 6. Publication IPC-7351 may have alternate designs.
- 7. Solder mask tolerances between and around signal pads can vary based on board fabrication site.

EXAMPLE STENCIL DESIGN

DB0020A

TSSOP - 2 mm max height

SMALL OUTLINE PACKAGE



SOLDER PASTE EXAMPLE
BASED ON 0.125 mm THICK STENCIL
SCALE: 10X

4214851/A 12/2017

NOTES: (continued)

8. Laser cutting apertures with trapezoidal walls and rounded corners may offer better paste release. IPC-7525 may have alternate design recommendations.
9. Board assembly site may have different recommendations for stencil design.

DW0020A



PACKAGE OUTLINE

SOIC - 2.65 mm max height

SOIC



NOTES:

1. All linear dimensions are in millimeters. Dimensions in parenthesis are for reference only. Dimensioning and tolerancing per ASME Y14.5M.
2. This drawing is subject to change without notice.
3. This dimension does not include mold flash, protrusions, or gate burrs. Mold flash, protrusions, or gate burrs shall not exceed 0.15 mm per side.
4. This dimension does not include interlead flash. Interlead flash shall not exceed 0.43 mm per side.
5. Reference JEDEC registration MS-013.

EXAMPLE BOARD LAYOUT

DW0020A

SOIC - 2.65 mm max height

SOIC



LAND PATTERN EXAMPLE
SCALE:6X

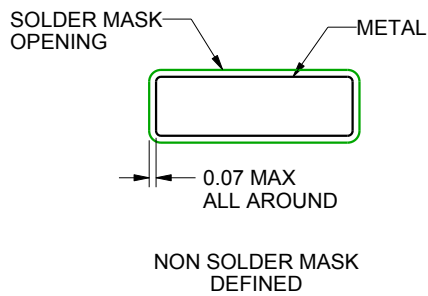

NON SOLDER MASK
DEFINED

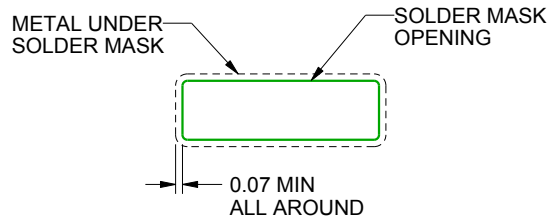

SOLDER MASK
DEFINED

SOLDER MASK DETAILS

4220724/A 05/2016

NOTES: (continued)

- 6. Publication IPC-7351 may have alternate designs.
- 7. Solder mask tolerances between and around signal pads can vary based on board fabrication site.

EXAMPLE STENCIL DESIGN

DW0020A

SOIC - 2.65 mm max height

SOIC



SOLDER PASTE EXAMPLE
BASED ON 0.125 mm THICK STENCIL
SCALE:6X

4220724/A 05/2016

NOTES: (continued)

8. Laser cutting apertures with trapezoidal walls and rounded corners may offer better paste release. IPC-7525 may have alternate design recommendations.
9. Board assembly site may have different recommendations for stencil design.

IMPORTANT NOTICE AND DISCLAIMER

TI PROVIDES TECHNICAL AND RELIABILITY DATA (INCLUDING DATASHEETS), DESIGN RESOURCES (INCLUDING REFERENCE DESIGNS), APPLICATION OR OTHER DESIGN ADVICE, WEB TOOLS, SAFETY INFORMATION, AND OTHER RESOURCES "AS IS" AND WITH ALL FAULTS, AND DISCLAIMS ALL WARRANTIES, EXPRESS AND IMPLIED, INCLUDING WITHOUT LIMITATION ANY IMPLIED WARRANTIES OF MERCHANTABILITY, FITNESS FOR A PARTICULAR PURPOSE OR NON-INFRINGEMENT OF THIRD PARTY INTELLECTUAL PROPERTY RIGHTS.

These resources are intended for skilled developers designing with TI products. You are solely responsible for (1) selecting the appropriate TI products for your application, (2) designing, validating and testing your application, and (3) ensuring your application meets applicable standards, and any other safety, security, or other requirements. These resources are subject to change without notice. TI grants you permission to use these resources only for development of an application that uses the TI products described in the resource. Other reproduction and display of these resources is prohibited. No license is granted to any other TI intellectual property right or to any third party intellectual property right. TI disclaims responsibility for, and you will fully indemnify TI and its representatives against, any claims, damages, costs, losses, and liabilities arising out of your use of these resources.

TI's products are provided subject to TI's Terms of Sale (www.ti.com/legal/termsofsale.html) or other applicable terms available either on ti.com or provided in conjunction with such TI products. TI's provision of these resources does not expand or otherwise alter TI's applicable warranties or warranty disclaimers for TI products.

Mailing Address: Texas Instruments, Post Office Box 655303, Dallas, Texas 75265
Copyright © 2018, Texas Instruments Incorporated

Looking for pricing, stock, or lifecycle information?

Click below to explore more details on WIN SOURCE:

- ⊖ [View SN74LV374ANSR on WIN SOURCE](#)
- ⊖ [Texas Instruments](#) Information

Optimize Your Supply Chain with WIN SOURCE Solutions

- ✓ Global Sourcing Solution
- ✓ Obsolete Management
- ✓ Cost Control Management
- ✓ Shortage Management
- ✓ Alternative Solution
- ✓ Excess Inventory Management