



**THE DATASHEET OF
BQ76PL102RGTT**



PowerLAN™ Dual-Cell Li-Ion Battery Monitor With PowerPump™ Cell Balancing

FEATURES

- **Monitors up to Two Individual Cell Voltages and Temperatures**
- **Part of a Complete Low-Cost Solution for Battery Packs of up to 12 Series and One or More Parallel Cells (When Used With bq78PL114).**
- **Advanced PowerPump™ Balancing Technology Equalizes Cells in Li-Ion Battery Packs, Resulting in Longer Run Time and Cell Life.**
- **PowerPump™ Cell Balancing Transfers Charge From Cell to Cell During all Operating Conditions – No Wasteful Current Bleeding or Associated Heat Buildup.**
- **Unique PowerLAN™ Isolated Communications Technology Permits Simultaneous Measurement of All Individual Cell Voltages in a Series String.**
- **Low Current Consumption:**
 - <250 μA Active
 - <35 μA Standby
 - <1 μA Undervoltage Shutdown
- **Connects Directly to Cells, No Resistive Dividers**
- **Internal LDO Regulator for Support Circuitry**
- **Ultrasmall Footprint, 3-mm \times 3-mm**
- **Millivolt Measurement Resolution Using Delta-Sigma A/D Converter**
- **Self-Calibrating Time Base – No Crystal Required When Used With bq78PL114**

APPLICATIONS

- **Uninterruptible Power Supplies (UPS)**
- **Portable Medical and Test Equipment**
- **Electric Bikes and Mild-EV Battery Packs**
- **Multicell Series Strings \geq 5S**

RELATED DEVICES

- **bq78PL114 Master Gateway Battery Controller**

DESCRIPTION

The bq76PL102 PowerLAN dual-cell battery monitor is part of a complete scalable battery management system for use with arrays of up to 12 Li-Ion rechargeable cells. The bq76PL102 connects to one or two cells in a series string, performs voltage and temperature monitoring of each individual cell, and reports these parameters over the PowerLAN communication network. Together with a bq78PL114 master-gateway battery controller, the bq76PL102 forms a complete battery monitoring and management system for higher cell-count applications.

Partitioning of the battery monitor function on a per cell basis permits connection and measurement close to the cell. This results in superior accuracy and management over competing solutions. This scheme also facilitates the PowerPump cell balancing system, a technique which actively balances capacities of Li-Ion batteries without the excessive heat or limitations of bleed-balancing techniques.

The bq76PL102 PowerPump cell balancing technology uses a charge-transfer methodology which does not bleed off excess energy as heat, but instead moves energy dynamically from cell to cell as needed. Balancing is performed during all battery operational modes – charge, discharge, and rest. Balancing is automatically coordinated between all cells on a PowerLAN system. PowerPump balancing technology results in longer run time and longer cell life.

The PowerLAN communications architecture has been engineered to provide robust communications in tough EMI/RFI environments while avoiding the excessive power draw, high parts count, and elevated cost of other solutions. PowerLAN permits easy scalability using series connections of bq76PL102 dual-cell battery monitors. High-cell-count battery systems of up to 12 series cells are easily constructed without complicated high-voltage cell measurement restrictions.

The bq76PL102 works with the bq78PL114 master-gateway battery controller.



Please be aware that an important notice concerning availability, standard warranty, and use in critical applications of Texas Instruments semiconductor products and disclaimers thereto appears at the end of this data sheet.

PowerPump, PowerLAN are trademarks of Texas Instruments.

bq76PL102

SLUS887A—DECEMBER 2008—REVISED OCTOBER 2009

www.ti.com



This integrated circuit can be damaged by ESD. Texas Instruments recommends that all integrated circuits be handled with appropriate precautions. Failure to observe proper handling and installation procedures can cause damage.

ESD damage can range from subtle performance degradation to complete device failure. Precision integrated circuits may be more susceptible to damage because very small parametric changes could cause the device not to meet its published specifications.

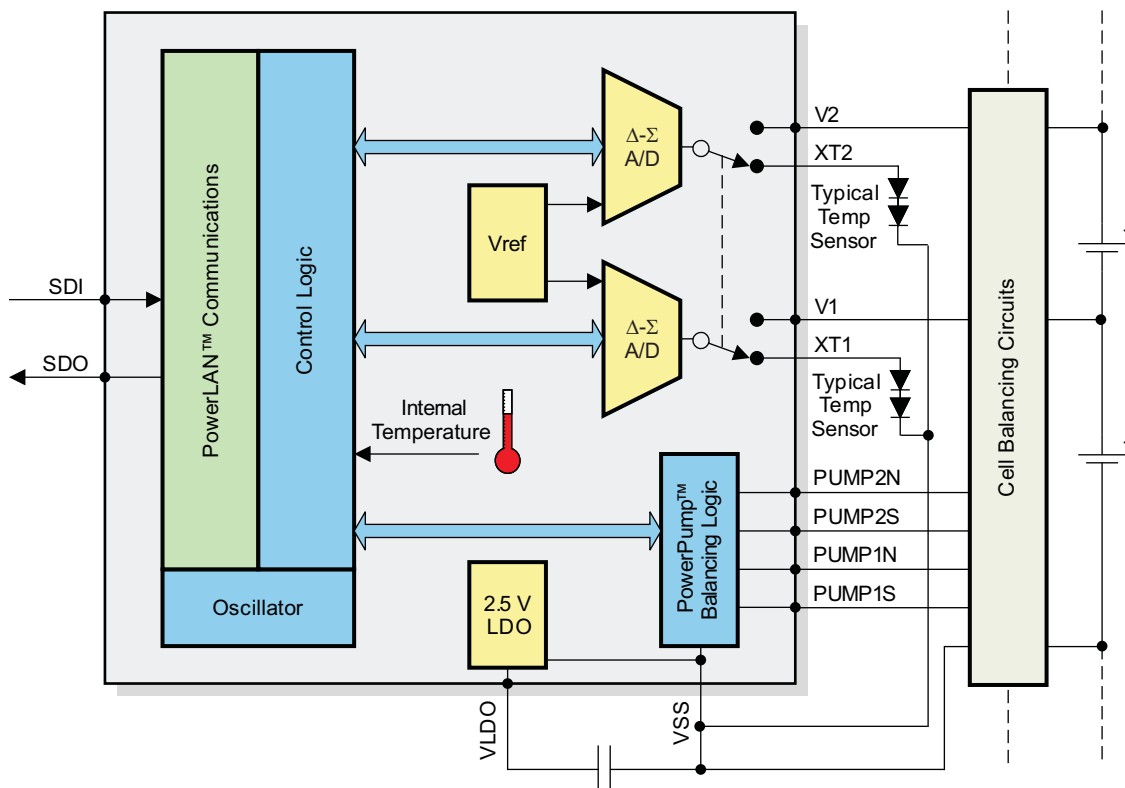

B0345-01

Figure 1. bq76PL102 Simplified Internal Block Diagram

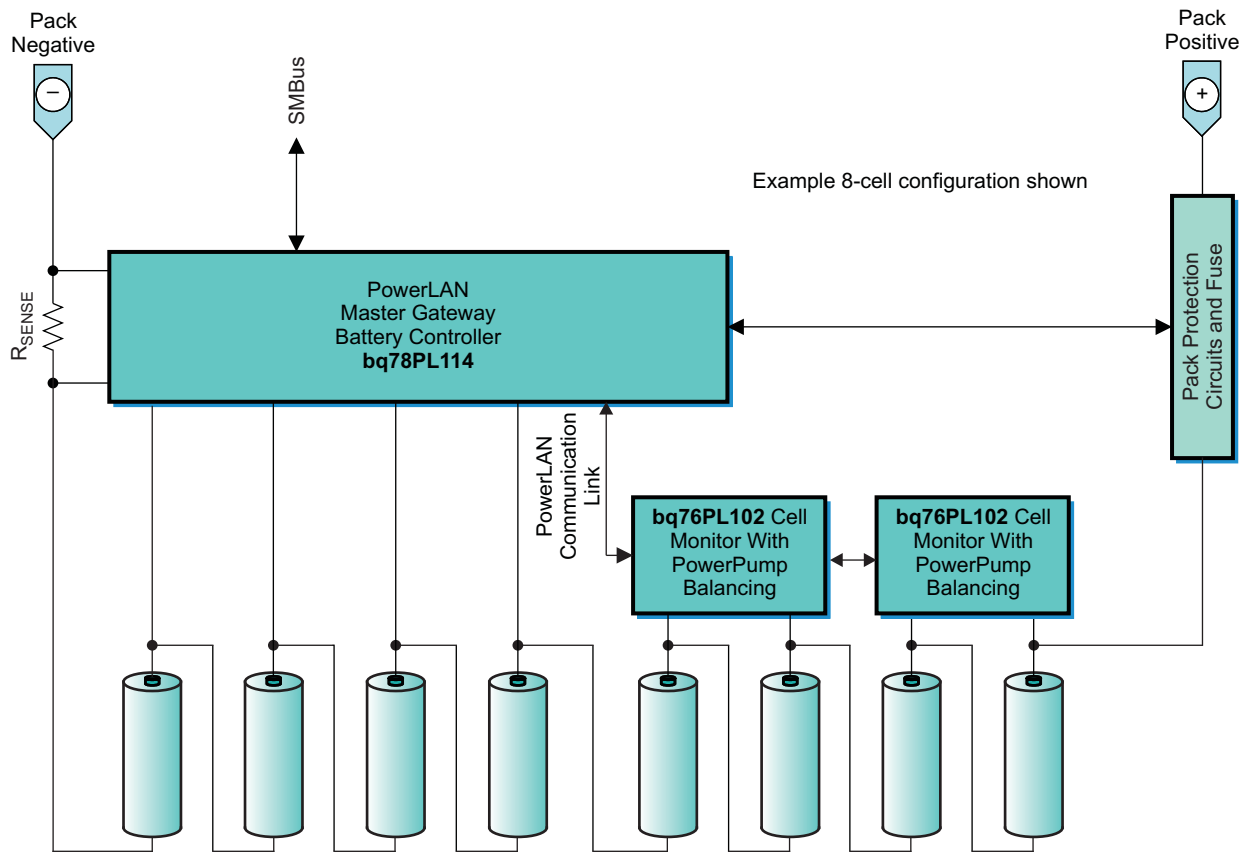

B0332-01

Figure 2. Example Multicell PowerLAN System Implementation

AVAILABLE OPTIONS

The bq76PL102 is currently available in a 3-mm square QFN-16 package, bq76PL102RGT, with a rated operational temperature range of -40°C to 85°C . (See Figure 5 for specific package information, dimensions, and tolerances.)

- Order bq76PL102RGTT for 250 quantity, tape and reel
- Order bq76PL102RGTR for 3000 quantity, tape and reel

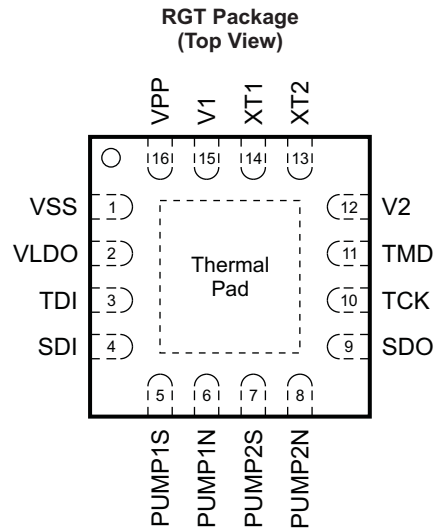

P0019-06

Figure 3. bq76PL102 Pinout (Top View)

CAUTION:

This device is subject to damage from Electrostatic Discharge (ESD). The device should be stored and handled using appropriate ESD precautions to prevent damage to the internal circuitry.

PIN FUNCTIONS

PIN		I/O ⁽¹⁾	DESCRIPTION ⁽²⁾
NAME	NO.		
PUMP1N	6	O	Charge-balance gate drive for cell 1 north
PUMP1S	5	O	Charge-balance gate drive for cell 1 south
PUMP2N	8	O	Charge-balance gate drive cell 2 north
PUMP2S	7	O	Charge-balance gate drive cell 2 south
SDI	4	I	PowerLAN serial data input from lower south, downstream part
SDO	9	O	PowerLAN serial data output to north, upstream part
XT1	14	IA	External temperature sensor 1 input (calibrated 50 μA)
XT2	13	IA	External temperature sensor 2 input (calibrated 50 μA)
TCK	10	NC	Do not connect
TDI	3	NC	Do not connect
TMD	11	NC	Do not connect
V1	15	IA	Midpoint cell connection (cell 1 positive and cell 2 negative)
V2	12	P, IA	Connect to most-positive cell voltage (cell 2 positive) ⁽³⁾
VLDO	2	P	Low-dropout regulator output – connect to VPP (bypass with 4.7 μF capacitor)
VPP	16	P	Connect to VLDO
VSS	1	P	Connect to most-negative cell voltage (cell 1 negative)
	—	P	Thermal pad – connect to VSS

(1) I - input, IA - analog input, O - output, P - power, NC - no connect

(2) Cell numbering convention is from more-negative (cell 1) to more-positive (cell 2) and is locally referenced.

(3) When there is an odd number of series cells in a battery pack, connect pin V2 of the topmost bq76PL102 to pin V1 of the same bq76PL102.

ABSOLUTE MAXIMUM RATINGS

 over operating free-air temperature range (unless otherwise noted) ⁽¹⁾

		VALUE	UNIT
T _A	Operating free-air temperature (ambient)	–40 to 85	°C
T _{stg}	Storage temperature	–65 to 150	°C
Voltage on SDO	Note: not VSS-referenced	(V1 – 0.5) to (V2 + 0.5) ⁽²⁾	V
Voltage on SDI	Limited by lower cell voltage	(VSS – 0.5) to (V1 + 0.5) ⁽²⁾	V
Voltage on V1 (V1 – VSS) ⁽²⁾	Maximum cell voltage	–0.5 to 5	V
Voltage on V2 (V2 – V1) ⁽²⁾	Maximum cell voltage (not VSS-referenced)	–0.5 to 5	V
Voltage on XT1 or XT2	With respect to VSS	(VSS – 0.5) to (V1 + 0.5)	V
ESD tolerance	JEDEC, JESD22-A114 human-body model, R = 1500 Ω, C = 100 pF	2	kV

- (1) Stresses beyond those listed under *Absolute Maximum Ratings* may cause permanent damage to the device. These are stress ratings only, and functional operation of the device at these or any other conditions beyond those indicated under *Recommended Operating Conditions* is not implied. Exposure to absolute-maximum-rated conditions for extended periods may affect device reliability.
- (2) Cell numbering convention is from most negative (Cell 1) to most positive (Cell 2) and is locally referenced.

ELECTRICAL CHARACTERISTICS

 T_A = –40°C to 85°C (unless otherwise noted)

PARAMETER		TEST CONDITIONS	MIN	TYP	MAX	UNIT
DC CHARACTERISTICS						
V _{CELL} ⁽¹⁾ Cell voltage input		Two-cell configuration	2.5	3.6	4.5	V
		One-cell configuration ⁽²⁾	2.8	3.6	4.5	
I _{DD}	Operating current (cell 2)	Measuring, reporting, or balancing		250	350	μA
I _{STBY}	Standby-mode current (cell 2)	Idle		32	50	μA
I _{SHIP}	Ship-mode current (cell 2)			10	30	μA
I _{UVM} ⁽³⁾	Cell extreme undervoltage-mode current (cell 2)	V1 < 2.8 V		0.5	1	μA
V _{Startup}	Minimum startup voltage, V1 and V2		2.9			V
CELL VOLTAGE MEASUREMENT CHARACTERISTICS						
	V1 measurement range		2.75		4.5	V
	V2 measurement range		2.75		4.5	V
	Analog resolution			<1		mV
Accuracy (after calibration)		25°C		±3	±7	mV
		0°C to 85°C		±10 ⁽⁴⁾		
	Measurement temperature coefficient			+150		μV/°C
	Conversion time ⁽⁵⁾				80	ms
INTERNAL TEMPERATURE MEASUREMENT CHARACTERISTICS						
	Measurement range		–30		85	°C
	Resolution			0.1		°C
	Accuracy (after calibration) ⁽⁴⁾	0°C to 85°C			±2	°C
	Temperature coefficient			+1.28		mV/°C

- (1) For single-cell operation, V1 must be connected to V2.
- (2) During operation after power up
- (3) Condition forced by bq78PL114
- (4) With respect to voltage shift induced by temperature coefficient at 85°C.
- (5) Does not include delay due to internode timing delays.

bq76PL102

SLUS887A–DECEMBER 2008–REVISED OCTOBER 2009

www.ti.com

ELECTRICAL CHARACTERISTICS (continued)

 $T_A = -40^{\circ}\text{C}$ to 85°C (unless otherwise noted)

PARAMETER	TEST CONDITIONS	MIN	TYP	MAX	UNIT	
EXTERNAL TEMPERATURE SENSOR(S) TYPICAL CHARACTERISTICS⁽⁶⁾						
Measurement range ⁽⁷⁾		-40		90	°C	
Resolution			0.2		°C	
Accuracy ⁽⁸⁾	25°C			±2	°C	
	0°C to 85°C			±2	°C	
PowerPump ELECTRICAL CHARACTERISTICS (FOR bq76PL102)⁽⁹⁾						
V _{OH}	High drive, PUMP1S, PUMP2S	I _{OUT} = 10 μA	0.9 V _I		V	
V _{OL}	Low drive, PUMP1S, PUMP2S	I _{OUT} = -200 μA		0.1 V _I	V	
V _{OH}	High drive, PUMP1N, PUMP2N	I _{OUT} = 200 μA	0.9 V _I		V	
V _{OL}	Low drive, PUMP1N, PUMP2N	I _{OUT} = -10 μA		0.1 V _I	V	
I _{OH}	Source current, PUMP1S, PUMP2S	V _{OH} = V _I - 0.8 V	250		μA	
I _{OL}	Sink current, PUMP1N, PUMP2N	V _{OH} = V _I + 0.2 V	-250		μA	
t _r	Signal rise time	C _{Load} = 300 pF		100	ns	
t _f	Signal FET fall time	C _{Load} = 300 pF		100	ns	
f _P	Frequency		204.8		kHz	
PWM duty cycle ⁽¹⁰⁾	PUMP1S, PUMP2S			67%		
	PUMP1N, PUMP2N			33%		
LDO VOLTAGE CHARACTERISTICS⁽¹¹⁾						
V _{LDO}	Single-cell operation, referenced to VSS	Load = 200 μA at 25°C, V _I = 2.8 V	2.425	2.5	2.575	V
V _{LDO}	Dual-cell operation, V ₁ = V ₂ = cell voltage	Load = 2 mA at 25°C	2.425	2.5	2.575	V
V_{LAN} SIGNALS⁽¹²⁾⁽¹³⁾⁽¹⁴⁾						
C _L	Load capacitance	SDI, C coupling = 1000 pf		100	pF	
		SDO		100		
V _{IH}	Input logic high	SDI	0.8 V _{LDO}		V	
V _{OH}	Output logic high	SDO	0.9 V _{LDO}		V	
V _{IL}	Input logic low	SDI		0.2 V _{LDO}	V	
V _{OL}	Output logic low	SDO		0.1 V _{LDO}	V	
t _r	Input rise time	SDI		500	ns	
t _f	Input fall time	SDI		500	ns	
t _{or}	Output rise time	SDO		30	50	ns
t _{of}	Output fall time	SDO		30	50	ns

(6) Typical for dual-diode (MMBD4148 or equivalent) external sensor using recommended circuit

(7) Range of diode sensors may exceed operation limits of IC and battery cells.

(8) Typical behavior after calibration; final result depends on specific component characteristics

(9) All parameters tested at typical cell voltages = 3.6 V.

(10) The frequency and duty cycle of each pump gate drive signal is set by the bq78PL114. The PUMPxN signals have a positive duty cycle and switch on the N-Channel MOSFETs. The duty cycle of the PUMPxS signals is (100 - the duty cycle of the PUMPxN signals).

(11) After calibration

(12) Values specified by design

(13) The SDI and SDO pins on the bq76PL102 are ac-coupled from the cell circuits downstream and upstream, respectively. The limits specified here are the voltage transitions which must occur within the SDI and SDO rise- and fall-time specifications.

(14) The value specified is over the full input voltage range and the maximum load capacitance.

FEATURE SET

The bq76PL102 dual-cell li-ion battery monitor with PowerPump balancing implements battery voltage measurement, temperature measurement, and balancing for one or two Li-Ion cells in series, and any number in parallel (limited by other design considerations).

Functions include:

- Two external temperature sensors are supported
- Simultaneous, synchronous measurement of all cell voltages in a series string
- Asynchronous reporting of most-recent measurements for each cell
- Fully independent measurements on a cell-by-cell basis
- PowerPump cell balancing using charge transfer from cell to cell
- PowerLAN isolated communications to other bq76PL102 devices or bq78PL114 master-gateway battery-management controller
- Low-power operation

OPERATION

Cell-Voltage Measurement

Voltage measurements are made using one-per-cell precision delta-sigma analog-to-digital converters (ADC). An internal calibrated band-gap voltage reference is provided with each part. Measurements are performed when commanded by the bq78PL114 master-gateway battery-management controller via the one-wire PowerLAN serial communications bus. This allows all cells to be measured at exactly the same time under the same load conditions.

Cell-Temperature Measurement

Temperature measurements can be obtained using one internal and up to two external sensors. Each external sensor consists of one (or two for increased accuracy) series-connected diodes and a capacitor for filtering. The use of dual diodes in a single SMT package is recommended (MMBD4148SE or equivalent). The diode can be located up to 6 inches (15 cm) from the circuit board. The RF filter capacitor should be co-located very close to the diode to minimize unwanted noise coupling.

The temperature measurement subsystem uses the same dual ADCs that are used for measuring voltages. Temperature measurements are fully independent of voltage readings, and are ordinarily interleaved at a fractional rate of the voltage readings by commands from the bq78PL114 master-gateway battery-management controller.

Cell Balancing

Balancing is provided among any number of supported cells. The bq76PL102 and PowerLAN family of master-gateway battery controllers is optimized for designs using more than four cells in series.

The patented PowerPump reactive cell balancing dramatically increases the useful life of battery systems by eliminating the cycle life fade of multicell batteries due to cell imbalance. PowerPump efficiently transfers charge from cell to cell, rather than simply bleeding off charging energy as heat. Charge is moved from higher-capacity cells to lower-capacity ones, and can be moved as needed between any number of series cell elements. Balancing is performed during all battery operational modes – charge, discharge, and rest. Compared to resistive bleed balancing, virtually no energy is lost as heat. The actual balance current is externally scalable with component selection and can range from 10 mA to 1 A (100 mA typical) depending on application or cell requirements. (See the reference schematic, [Figure 7](#).)

Algorithms for cell balancing are centrally coordinated by the bq78PL114 PowerLAN master-gateway battery-management controller and directed across the array of bq76PL102 dual-cell Li-Ion battery monitors. Balancing is done in both directions by the bq76PL102s within the cell stack array: *north* or up the cell stack and *south* or down the cell stack. Each bq76PL102 node provides the circuitry to transfer (pump) the charge from cell to cell to provide balancing. The balancing algorithm is implemented in the bq78PL114 master-gateway battery controller, and commands are communicated to the bq76PL102s via the PowerLAN communications link. By tracking the balancing required by individual cells, overall battery safety is enhanced – often allowing early detection of internal micro-shorts or other cell failures.

Cell balancing *pumping*, or charge transfer from one cell to another, is accomplished using a circuit that forms a simple flyback converter under control of the bq76PL102, which is in turn controlled by the master gateway. The outputs of PUMPnd (*cell number, direction*) control MOSFET transistors which charge an inductor from one cell and then discharge the inductor into an adjacent cell through the intrinsic body diode of the other MOSFET.

- **PUMP1S:** Pumps charge from cell 1 to the next lower cell (closer to battery negative). This signal is unused by the first or lowest cell in the string.
- **PUMP1N:** Pumps charge from cell 1 to cell 2.
- **PUMP2S:** Pumps charge from cell 2 to cell 1
- **PUMP2N:** Pumps charge from cell 2 to the next higher cell in a pack (closer to battery positive). This signal is unused by the highest cell in the string.

PowerLAN Communications

PowerLAN communications technology is a patented serial network and protocol designed specifically for battery management in a multicell environment. PowerLAN is used to initiate and report measurements of cell voltage and temperature, as well as control cell balancing. Using only a capacitor, PowerLAN isolates voltages from adjacent bq76PL102 parts to permit high-voltage stack assemblies without compromising precision and accuracy. PowerLAN is expandable to support up to 12 cells in series, with each bq76PL102 handling two series cells. PowerLAN provides high ESD standoff and high immunity to noise generated by nearby digital circuitry or switching currents. Each bq76PL102 has both a PowerLAN serial input and serial output pin. Received data is buffered and retransmitted, permitting high numbers of nodes without loss of signal fidelity. Signals are capacitor-coupled between nodes to provide high dc isolation.

Operation Modes

The bq76PL102 normally operates in one of two modes: active or standby. The bq76PL102 is normally in standby mode and consumes typically less than 50 μA . The low-dropout regulator output is still functional in this mode, as are internal system protection functions (undervoltage, communications timeout, etc.)

When a PowerLAN communications event occurs, then the bq76PL102 transitions to active mode and current drain increases to 250 μA typically. The bq76PL102 stays in this mode to complete any measurements or cell-balancing pumping operations. Once activity in this mode ceases, the return to standby is automatic, thus reducing overall power consumption.

An undervoltage ultralow-current mode is also available when initiated by the bq78PL114 master-gateway battery controller and when the cell voltages drop below a preset threshold. This mode is used to preserve battery capacity during long periods of non-use and therefore has a current drain of approximately 1 μA .

Note that cell balancing currents are external to the bq76PL102 and may be sized according to the needs of the application (typically 10 mA to 1 A). These currents are fixed by the cell-balancing circuitry and only enabled or disabled by the bq76PL102 (under control of the bq78PL114) to achieve the necessary cell-balance operations.

COMPLEMENTARY PRODUCTS

PowerLAN Master Gateway Battery Controller

The bq78PL114 master-gateway battery-management controller with PowerPump cell balancing from Texas Instruments is the central controller for a complete multicell battery system.

This advanced master-gateway battery controller works with up to 12 series cells monitored by bq76PL102 cell monitors to provide battery voltage, temperature, current and safety monitoring; state-of-charge and state-of-health information; system-wide internal PowerLAN communications; as well as external communications of battery parameters via the industry-standard SMBus interface.

bq76PL102

SLUS887A—DECEMBER 2008—REVISED OCTOBER 2009

www.ti.com

PowerLAN Six-Cell Battery Monitor

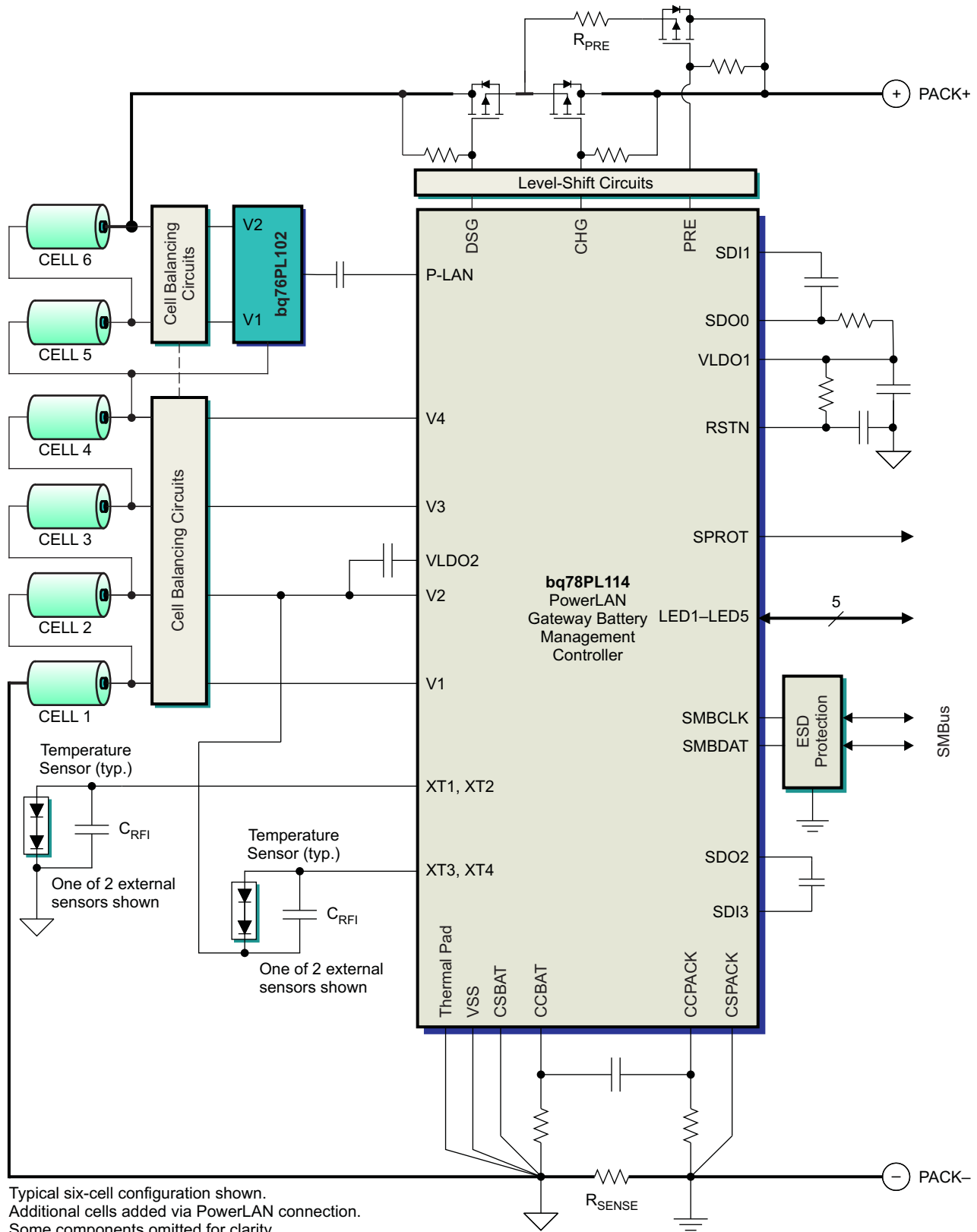

Typical six-cell configuration shown.
Additional cells added via PowerLAN connection.
Some components omitted for clarity.

S0342-03

Figure 4. bq78PL114 Simplified 6-Cell Gateway Controller Circuit With bq76PL102

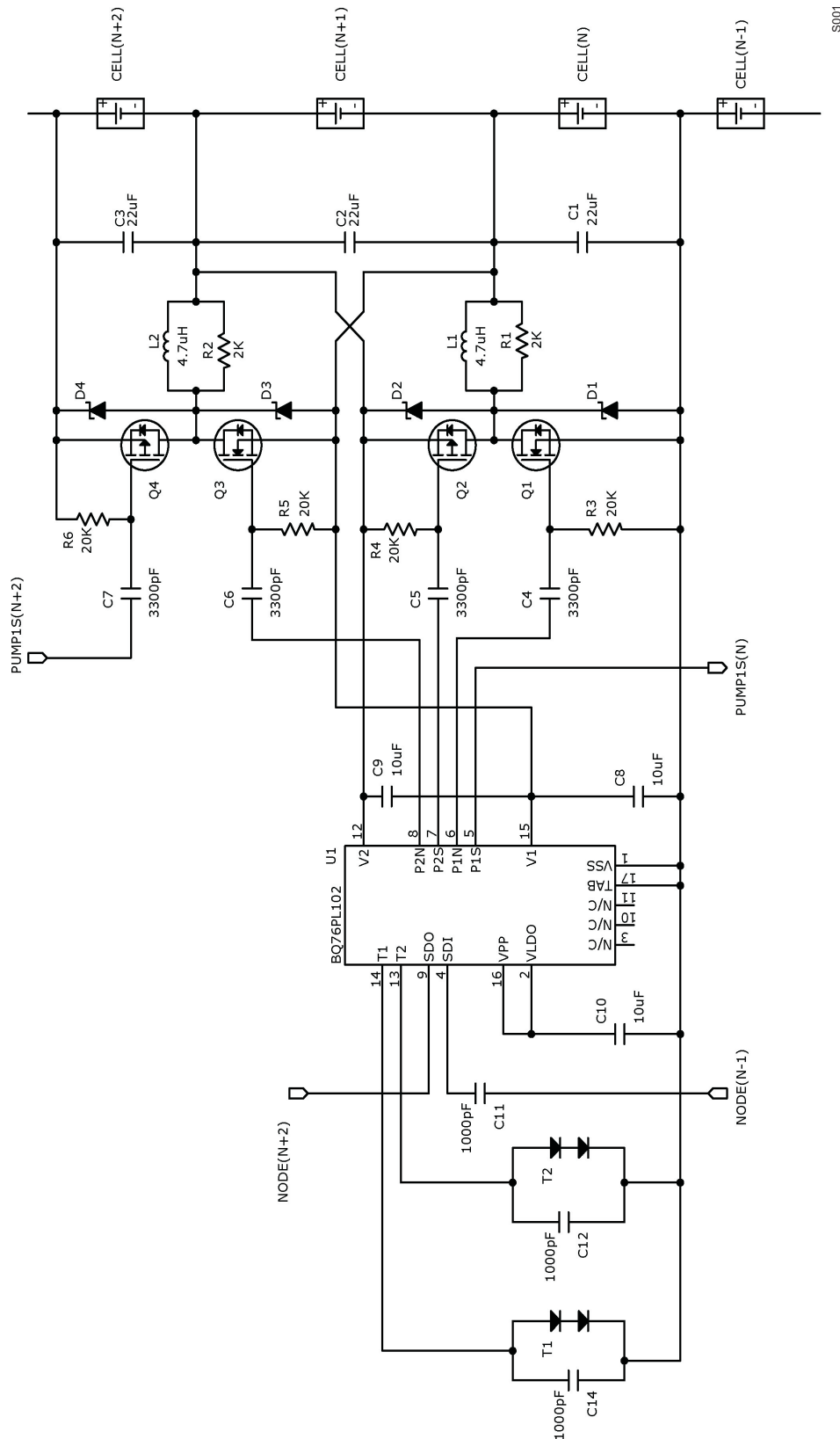

S001

Figure 6. Higher-Balancing-Current bq76PL102 Operating-Circuit Diagram

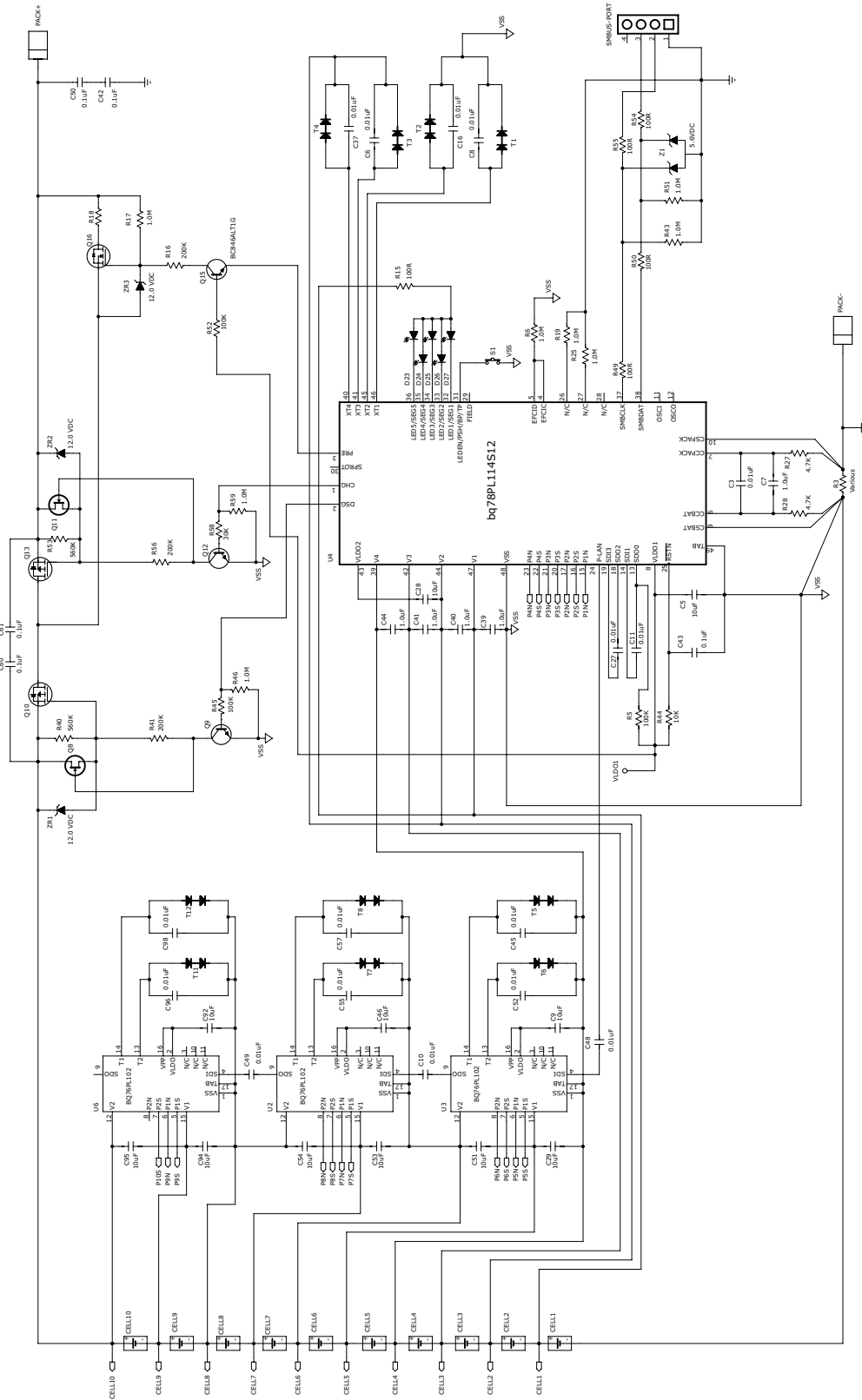
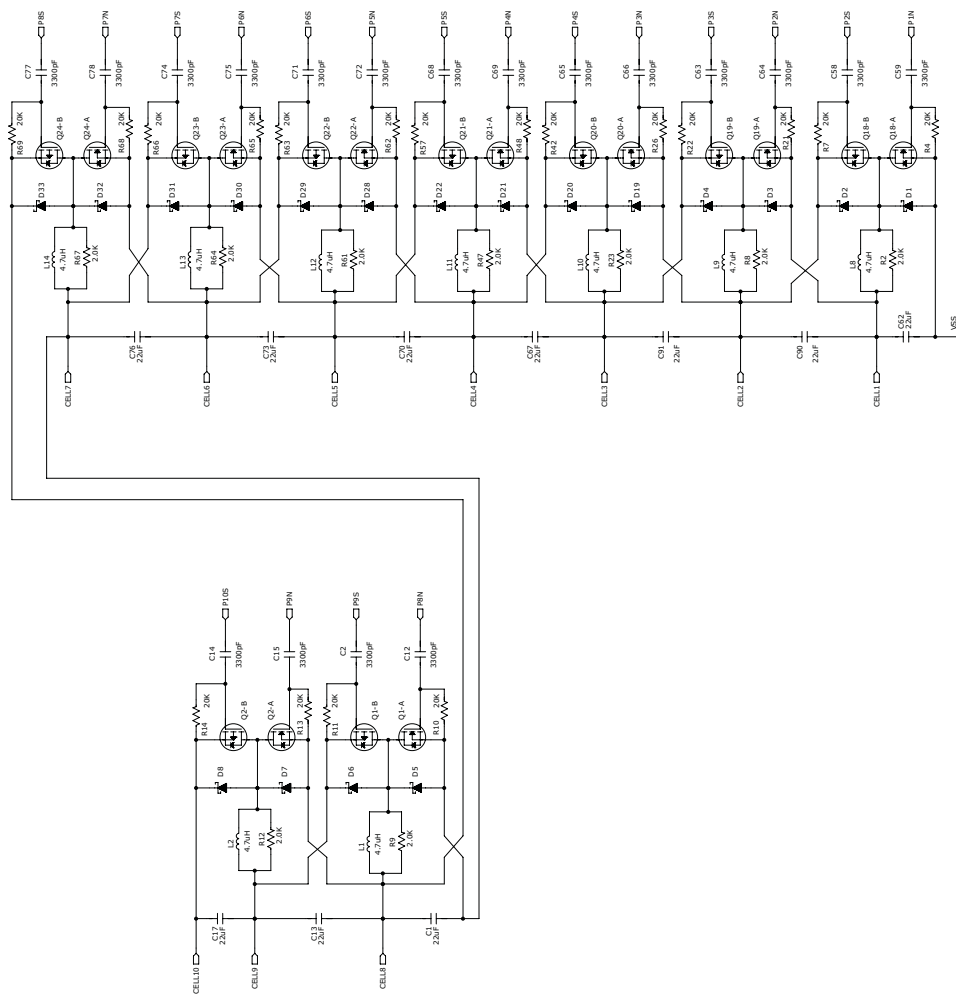

Figure 7. Reference Schematic (Sheet 1 of 2)



S002

Figure 8. Reference Schematic (Sheet 2 of 2)

PACKAGING INFORMATION

Orderable Device	Status (1)	Package Type	Package Drawing	Pins	Package Qty	Eco Plan (2)	Lead/Ball Finish (6)	MSL Peak Temp (3)	Op Temp (°C)	Device Marking (4/5)	Samples
BQ76PL102RGTR	NRND	VQFN	RGT	16	3000	Green (RoHS & no Sb/Br)	CU NIPDAU	Level-3-260C-168 HR	-40 to 85	OAG	
BQ76PL102RGTT	NRND	VQFN	RGT	16	250	Green (RoHS & no Sb/Br)	CU NIPDAU	Level-3-260C-168 HR	-40 to 85	OAG	

(1) The marketing status values are defined as follows:

ACTIVE: Product device recommended for new designs.

LIFEBUY: TI has announced that the device will be discontinued, and a lifetime-buy period is in effect.

NRND: Not recommended for new designs. Device is in production to support existing customers, but TI does not recommend using this part in a new design.

PREVIEW: Device has been announced but is not in production. Samples may or may not be available.

OBSELETE: TI has discontinued the production of the device.

(2) **RoHS:** TI defines "RoHS" to mean semiconductor products that are compliant with the current EU RoHS requirements for all 10 RoHS substances, including the requirement that RoHS substance do not exceed 0.1% by weight in homogeneous materials. Where designed to be soldered at high temperatures, "RoHS" products are suitable for use in specified lead-free processes. TI may reference these types of products as "Pb-Free".

RoHS Exempt: TI defines "RoHS Exempt" to mean products that contain lead but are compliant with EU RoHS pursuant to a specific EU RoHS exemption.

Green: TI defines "Green" to mean the content of Chlorine (Cl) and Bromine (Br) based flame retardants meet JS709B low halogen requirements of <=1000ppm threshold. Antimony trioxide based flame retardants must also meet the <=1000ppm threshold requirement.

(3) MSL, Peak Temp. - The Moisture Sensitivity Level rating according to the JEDEC industry standard classifications, and peak solder temperature.

(4) There may be additional marking, which relates to the logo, the lot trace code information, or the environmental category on the device.

(5) Multiple Device Markings will be inside parentheses. Only one Device Marking contained in parentheses and separated by a "~" will appear on a device. If a line is indented then it is a continuation of the previous line and the two combined represent the entire Device Marking for that device.

(6) Lead/Ball Finish - Orderable Devices may have multiple material finish options. Finish options are separated by a vertical ruled line. Lead/Ball Finish values may wrap to two lines if the finish value exceeds the maximum column width.

Important Information and Disclaimer:The information provided on this page represents TI's knowledge and belief as of the date that it is provided. TI bases its knowledge and belief on information provided by third parties, and makes no representation or warranty as to the accuracy of such information. Efforts are underway to better integrate information from third parties. TI has taken and continues to take reasonable steps to provide representative and accurate information but may not have conducted destructive testing or chemical analysis on incoming materials and chemicals. TI and TI suppliers consider certain information to be proprietary, and thus CAS numbers and other limited information may not be available for release.

In no event shall TI's liability arising out of such information exceed the total purchase price of the TI part(s) at issue in this document sold by TI to Customer on an annual basis.

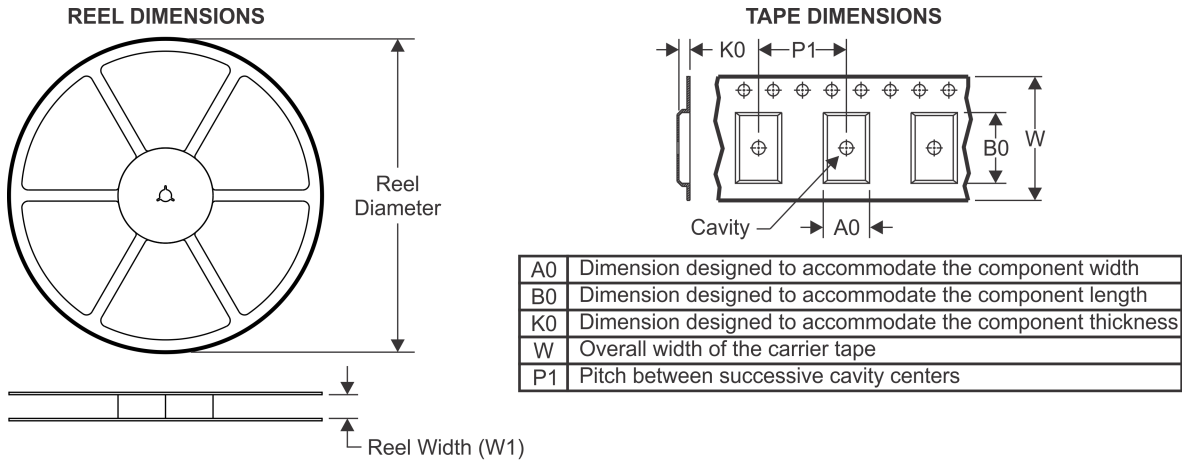
TAPE AND REEL INFORMATION

QUADRANT ASSIGNMENTS FOR PIN 1 ORIENTATION IN TAPE

*All dimensions are nominal

Device	Package Type	Package Drawing	Pins	SPQ	Reel Diameter (mm)	Reel Width W1 (mm)	A0 (mm)	B0 (mm)	K0 (mm)	P1 (mm)	W (mm)	Pin1 Quadrant
BQ76PL102RGTR	VQFN	RGT	16	3000	330.0	12.4	3.3	3.3	1.1	8.0	12.0	Q2
BQ76PL102RGTT	VQFN	RGT	16	250	180.0	12.4	3.3	3.3	1.1	8.0	12.0	Q2

TAPE AND REEL BOX DIMENSIONS



*All dimensions are nominal

Device	Package Type	Package Drawing	Pins	SPQ	Length (mm)	Width (mm)	Height (mm)
BQ76PL102RGTR	VQFN	RGT	16	3000	367.0	367.0	35.0
BQ76PL102RGTT	VQFN	RGT	16	250	210.0	185.0	35.0

RGT 16

GENERIC PACKAGE VIEW

VQFN - 1 mm max height

PLASTIC QUAD FLATPACK - NO LEAD

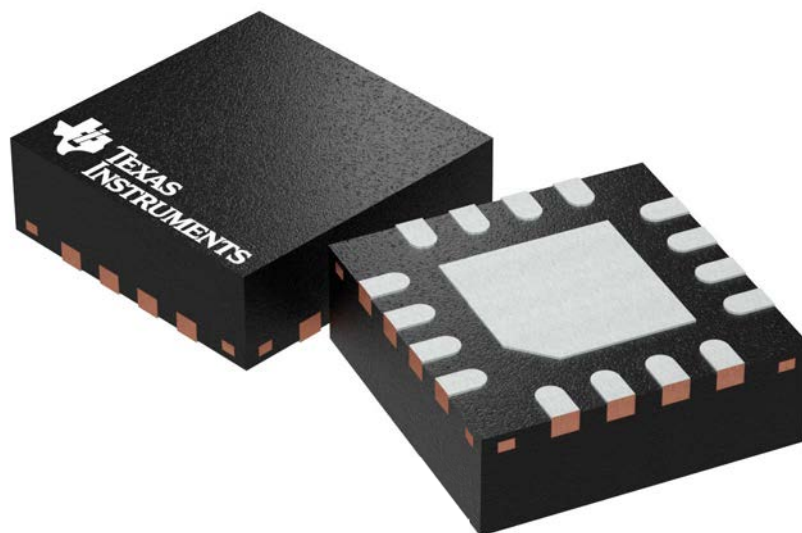

Images above are just a representation of the package family, actual package may vary.
Refer to the product data sheet for package details.

4203495/1

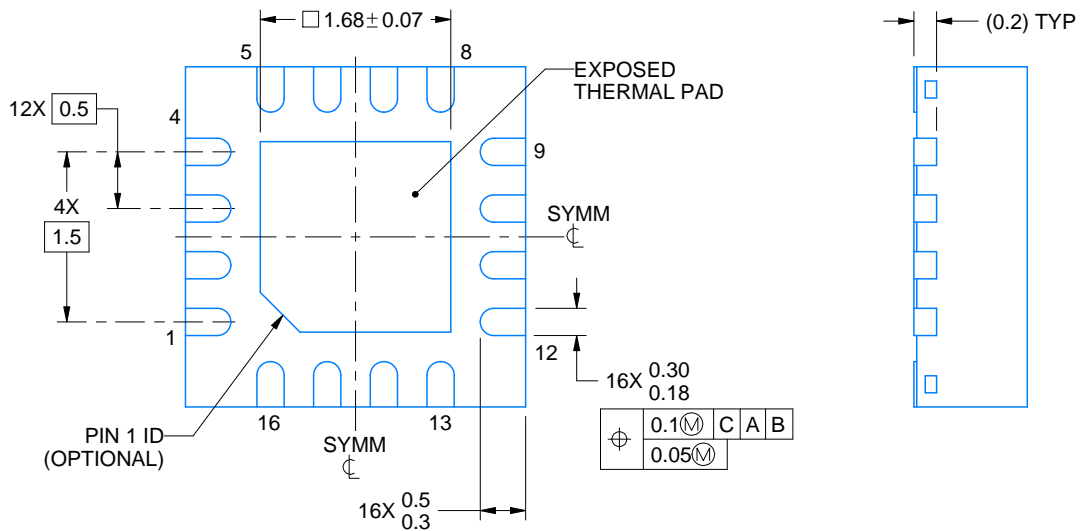
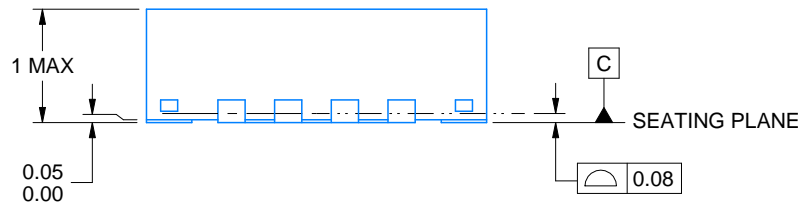
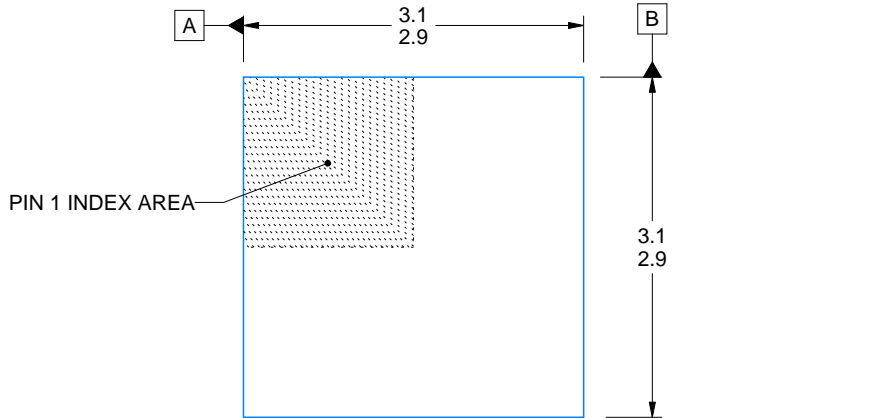
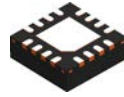

4222419/B 11/2016

NOTES:

1. All linear dimensions are in millimeters. Any dimensions in parenthesis are for reference only. Dimensioning and tolerancing per ASME Y14.5M.
2. This drawing is subject to change without notice.
3. The package thermal pad must be soldered to the printed circuit board for thermal and mechanical performance.

IMPORTANT NOTICE AND DISCLAIMER

TI PROVIDES TECHNICAL AND RELIABILITY DATA (INCLUDING DATASHEETS), DESIGN RESOURCES (INCLUDING REFERENCE DESIGNS), APPLICATION OR OTHER DESIGN ADVICE, WEB TOOLS, SAFETY INFORMATION, AND OTHER RESOURCES "AS IS" AND WITH ALL FAULTS, AND DISCLAIMS ALL WARRANTIES, EXPRESS AND IMPLIED, INCLUDING WITHOUT LIMITATION ANY IMPLIED WARRANTIES OF MERCHANTABILITY, FITNESS FOR A PARTICULAR PURPOSE OR NON-INFRINGEMENT OF THIRD PARTY INTELLECTUAL PROPERTY RIGHTS.

These resources are intended for skilled developers designing with TI products. You are solely responsible for (1) selecting the appropriate TI products for your application, (2) designing, validating and testing your application, and (3) ensuring your application meets applicable standards, and any other safety, security, or other requirements. These resources are subject to change without notice. TI grants you permission to use these resources only for development of an application that uses the TI products described in the resource. Other reproduction and display of these resources is prohibited. No license is granted to any other TI intellectual property right or to any third party intellectual property right. TI disclaims responsibility for, and you will fully indemnify TI and its representatives against, any claims, damages, costs, losses, and liabilities arising out of your use of these resources.

TI's products are provided subject to TI's Terms of Sale (www.ti.com/legal/termsofsale.html) or other applicable terms available either on ti.com or provided in conjunction with such TI products. TI's provision of these resources does not expand or otherwise alter TI's applicable warranties or warranty disclaimers for TI products.

Mailing Address: Texas Instruments, Post Office Box 655303, Dallas, Texas 75265
Copyright © 2019, Texas Instruments Incorporated

Looking for pricing, stock, or lifecycle information?

Click below to explore more details on WIN SOURCE:

 [View BQ76PL102RGTT](#) on WIN SOURCE

 [Texas Instruments](#) Information

Optimize Your Supply Chain with WIN SOURCE Solutions

-  Global Sourcing Solution
-  Obsolete Management
-  Cost Control Management
-  Shortage Management
-  Alternative Solution
-  Excess Inventory Management