



**THE DATASHEET OF
PI3B3126LE**



3.3V, 4-Bit, 2-Port Nanoswitchw/Individual Enables

Features

- Near zero propagation delay
- 5 Ohm switches connect inputs to outputs
- Fast Switching Speed - 4ns max.
- Ultra Low Quiescent Power (0.1µA Typical)
 - Ideally suited for notebook applications
- Packages available:
 - 14-pin, SOIC (W)
 - 14-pin, TSSOP (L)
 - 14-pin, TQFN (ZDB)
 - 16-pin, QSOP (Q)

Description

Diodes' PI3B series of logic circuits are produced using the Company's advanced sub micron CMOS technology, achieving industry leading speed grades.

The PI3B3125 and PI3B3126 are 3.3 Volt, 4-bit bus switches designed with four individual 5 Ohm bus switches with fast individual enables in an industry standard 74XX125/126 pinout. When enabled via the associated Bus Enable (\overline{BE}) pin, the "A" pin is directly connected to the "B" pin for that particular gate. The bus switch introduces no additional propagation delay or additional ground bounce noise.

The PI3B3125 device has active LOW enables, and the PI3B3126 has active HIGH enables.

PI3B3125 Logic Block Diagram

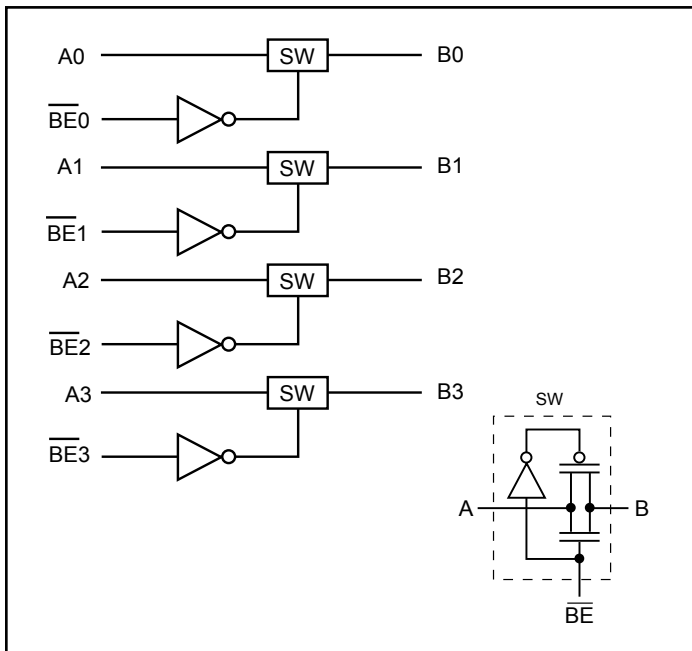

PI3B3126 Logic Block Diagram

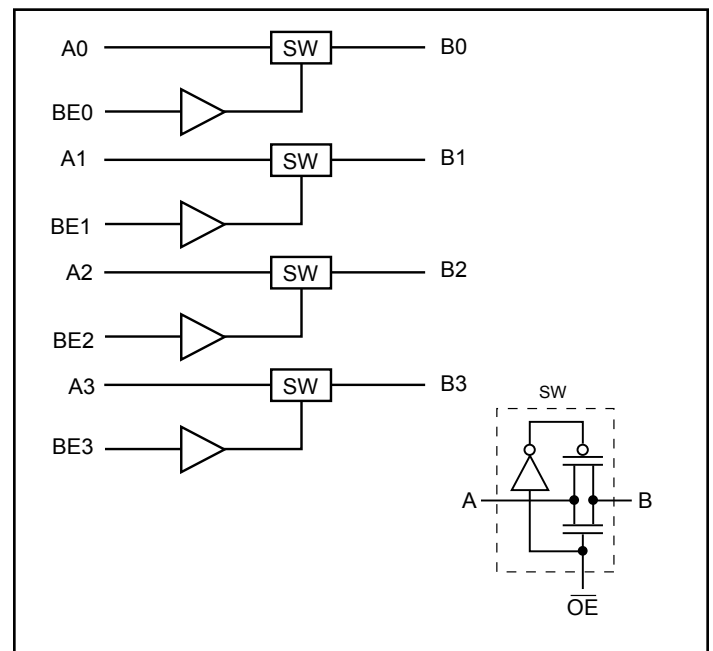

PI3B3125
14-Pin Product Configuration (SOIC, TSSOP)

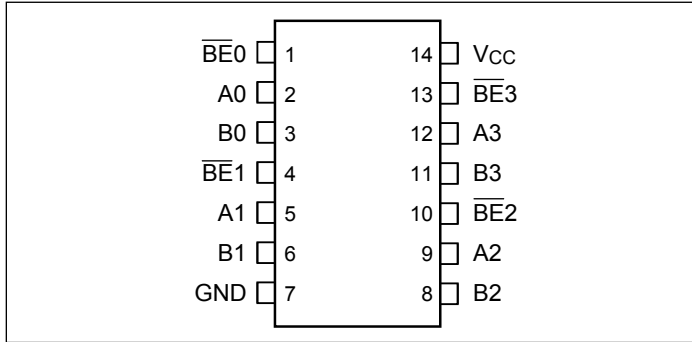

PI3B3126
14-Pin Product Configuration (SOIC, TSSOP)

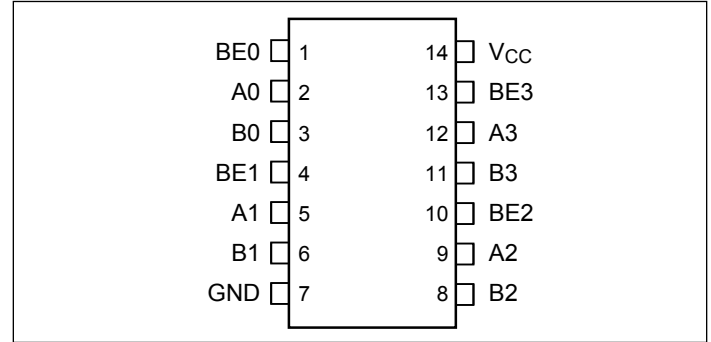

PI3B3125
16-Pin Product Configuration (QSOP)

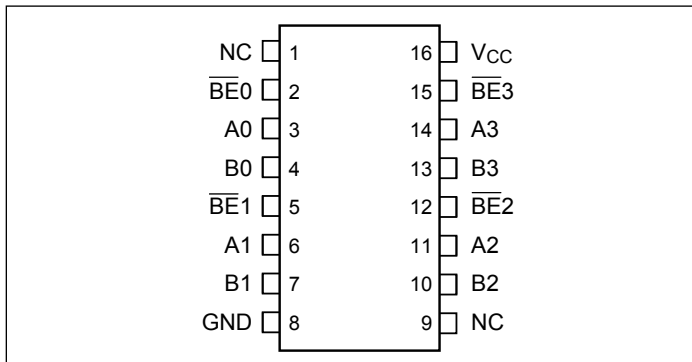

PI3B3126
14-Pin Product Configuration (TQFN)

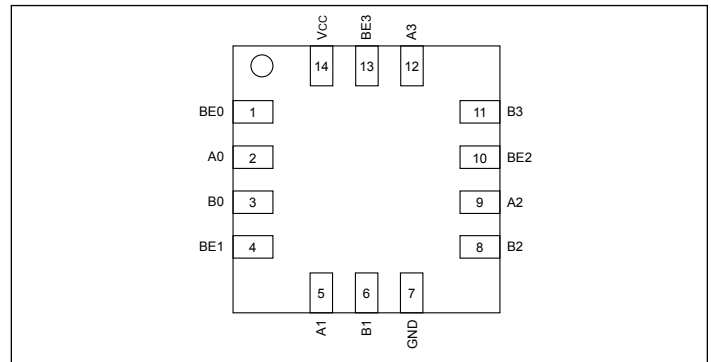

Pin Description

Pin Name	Description
$\overline{\text{BE}}_n$	Switch Enable (PI3B3125)
BE_n	Switch Enable (PI3B3126)
A3-A0	Bus A
B3-B0	Bus B
V_{CC}	Power
GND	Ground

PI3B3126
16-Pin Product Configuration (QSOP)

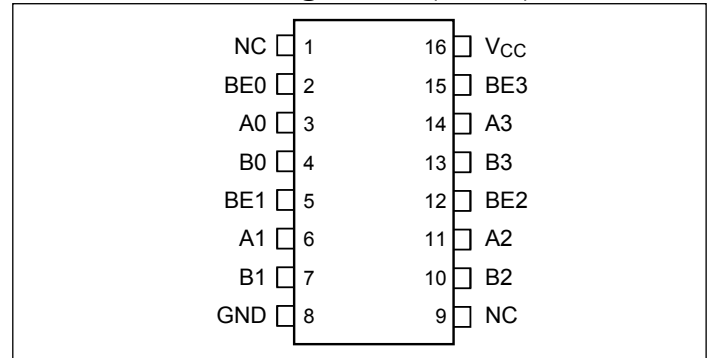

Truth Table⁽¹⁾

PI3B3125	PI3B3126	$\overline{\text{BE}}_n$	BE_n	A_n	B_n	V_{CC}	Function
		X ⁽²⁾	X	Hi-Z	Hi-Z	GND	Disconnect
		H	L	Hi-Z	Hi-Z	V_{CC}	Disconnect
		L	H	B_n	A_n	V_{CC}	Connect

Notes:

- H = High Voltage Level, L = Low Voltage Level
HI-Z = High Impedance, X = Don't Care
- A pull-up resistor should be provided for power-up protection.

Maximum Ratings

(Above which the useful life may be impaired. For user guidelines, not tested.)

Storage Temperature	-65°C to +150°C
Ambient Temperature with Power Applied	-40°C to +85°C
Supply Voltage to Ground Potential.....	-0.5V to +4.6V
DC Input Voltage	-0.5V to +4.6V
DC Output Current.....	120mA
Power Dissipation.....	0.5W

Note:

Stresses greater than those listed under MAXIMUM RATINGS may cause permanent damage to the device. This is a stress rating only and functional operation of the device at these or any other conditions above those indicated in the operational sections of this specification is not implied. Exposure to absolute maximum rating conditions for extended periods may affect reliability.

DC Electrical Characteristics

(Over the Operating Range, $T_A = -40^\circ\text{C}$ to $+85^\circ\text{C}$, $V_{CC} = 3.3\text{V} \pm 10\%$)

Parameter	Description	Test Conditions ⁽¹⁾	Min.	Typ. ⁽²⁾	Max.	Units
V_{IH}	Input HIGH Voltage	Guaranteed Logic HIGH Level	2.0			V
V_{IL}	Input LOW Voltage	Guaranteed Logic LOW Level	-0.5		0.8	V
I_{IH}	Input HIGH Current	$V_{CC} = \text{Max.}, V_{IN} = V_{CC}$			± 1	MA
I_{IL}	Input LOW Current	$V_{CC} = \text{Max.}, V_{IN} = \text{GND}$			± 1	MA
I_{OFF}	Off Current	$V_{CC} = 0, V_{OUT} = 3$ to 3.6V			10	MA
V_{IK}	Clamp Diode Voltage	$V_{CC} = \text{Min.}, I_{IN} = -18\text{mA}$			-1.2	V
R_{ON}	Switch On Resistance ⁽³⁾	$V_{CC} = \text{Min.}, V_{IN} = 0.0\text{V}, I_{ON} = 48\text{mA}$ or 60mA		5	8	Ω
		$V_{CC} = \text{Min.}, V_{IN} = 2.4\text{V}, I_{ON} = 15\text{mA}$		10	17	

Notes:

- For Max. or Min. conditions, use appropriate value specified under Electrical Characteristics for the applicable device type.
- Typical values are at $V_{CC} = 3.3\text{V}$, $T_A = 25^\circ\text{C}$ ambient and maximum loading.
- Measured by the voltage drop between A and B pin at indicated current through the switch. ON resistance is determined by the lower of the voltages on the two (A, B) pins.

Capacitance

($T_A = 25^\circ\text{C}$, $f = 1\text{MHz}$)

Parameter ⁽¹⁾	Description	Test Conditions	Min.	Typ.	Max.	Units
C_{IN}	Input Capacitance	$V_{IN} = 0\text{V}$		3.5		pF
C_{OFF}	A/B Capacitance, Switch Off	$V_{IN} = 0\text{V}$		8		pF

Note:

- This parameter is determined by device characterization but is not production tested.

Power Supply Characteristics

Parameter	Description	Test Conditions ⁽¹⁾		Min.	Typ. ⁽²⁾	Max.	Units
I_{CC}	Quiescent Power Supply Current	$V_{CC} = \text{Max.}$	$V_{IN} = \text{GND}$ or V_{CC}		0.1	3	μA
ΔI_{CC}	Supply Current per Input HIGH	$V_{CC} = \text{Max.}$	$V_{IN} = 3.0\text{V}^{(3)}$			750	μA

Notes:

- For Max. or Min. conditions, use appropriate value specified under Electrical Characteristics for the applicable device.
- Typical values are at $V_{CC} = 3.3\text{V}$, $+25^\circ\text{C}$ ambient.
- Per driven input (control inputs only); A and B pins do not contribute to I_{CC} .

PI3B3125 Switching Characteristics over Operating Range

Parameter	Description	Conditions ⁽¹⁾	PI3B3125		Units
			Com.		
			Min.	Max.	
t_{PLH} t_{PHL}	Propagation Delay ^(2,3) Ax to Bx, Bx to Ax	$C_L = 50\text{pF}$ $R_L = 500\Omega$		0.25	ns
t_{PZH} t_{PZL}	Bus Enable Time	$C_L = 50\text{pF}$ $R_L = 500\Omega$	1.0	3.0	ns
t_{PHZ} t_{PLZ}	Bus Disable Time	$R_L = 500\Omega$	1.0	4.0	ns

PI3B3126 Switching Characteristics over Operating Range

Parameter	Description	Conditions ⁽¹⁾	PI3B3126		Units
			Com.		
			Min.	Max.	
t_{PLH} t_{PHL}	Propagation Delay ^(2,3) Ax to Bx, Bx to Ax	$C_L = 50\text{pF}$ $R_L = 500\Omega$		0.25	ns
t_{PZH} t_{PZL}	Bus Enable Time	$C_L = 50\text{pF}$ $R_L = 500\Omega$	1.0	2.5	ns
t_{PHZ} t_{PLZ}	Bus Disable Time	$R_L = 500\Omega$	1.0	4.0	ns

Notes:

1. See test circuit and waveforms.
2. This parameter is guaranteed but not tested on Propagation Delays.
3. The bus switch contributes no propagational delay other than the RC delay of the ON resistance of the switch and the load capacitance. The time constant for the switch alone is of the order of 0.25ns for 50pF load. Since this time constant is much smaller than the rise/fall times of typical driving signals, it adds very little propagational delay to the system. Propagational delay of the bus switch when used in a system is determined by the driving circuit on the driving side of the switch and its interaction with the load on the driven side.

Applications Information

Logic Inputs

The logic control inputs can be driven up to +3.6V regardless of the supply voltage. For example, given a + 3.3V supply, IN may be driven low to 0V and high to 3.6V. Driving IN Rail-to-Rail® minimizes power consumption.

Power-Supply Sequencing and Hot-Plug Information

Proper power-supply sequencing is recommended for all CMOS devices. Always apply V_{CC} and GND before applying signals to in-put/output or control pins.

Rail-to-Rail is a registered trademark of Nippon Motorola, Ltd.

PI3B3125 Part Marking

L Package

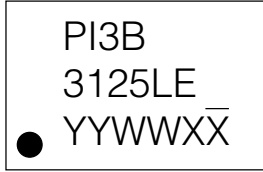

YY: Year
WW: Workweek
1st X: Assembly Site Code
2nd X: Fab Site Code

Q Package

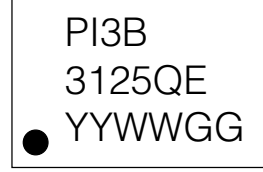

YY: Year
WW: Workweek
1st G: Assembly Site Code
2nd G: Wafer Fab Site Code

W Package



YY: Year
WW: Workweek
1st X: Assembly Site Code
2nd X: Wafer Fab Site Code

PI3B3126 Part Marking

L Package

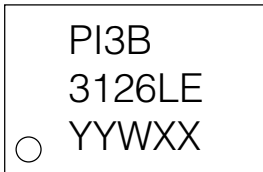

1st Y: Die Rev
2nd Y: Year
W: Workweek
1st X: Assembly Code
2nd X: Fab Code

Q Package

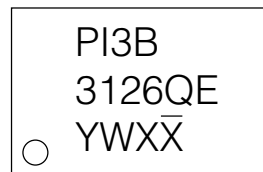

Y: Year
W: Workweek
1st X: Assembly Site Code
2nd X: Fab Site Code

W Package



YY: Year
WW: Workweek
1st X: Assembly Site Code
2nd X: Wafer Fab Site Code

ZDB Package



YY: Year
WW: Workweek
1st X: Assembly Site Code
2nd X: Fab Site Code

Packaging Mechanical: 14-TSSOP (L)

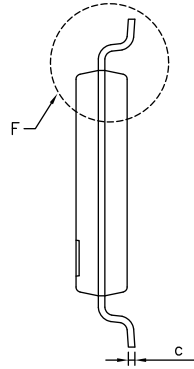
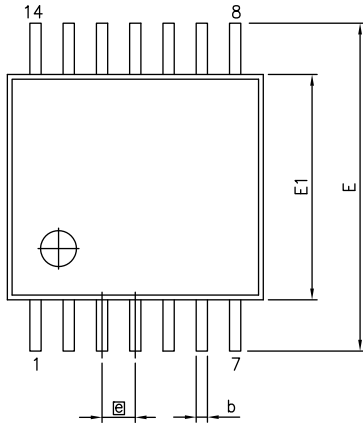

SYMBOLS	MIN.	NOM.	MAX.
A	–	–	1.20
A1	0.05	–	0.15
A2	0.80	1.00	1.05
b	0.19	–	0.30
c	0.09	–	0.20
D	4.90	5.00	5.10
E1	4.30	4.40	4.50
E	6.20	6.40	6.60
e	0.65 BSC		
L1	1.00 REF		
L	0.45	0.60	0.75
S	0.20	–	–
θ	0°	–	8°

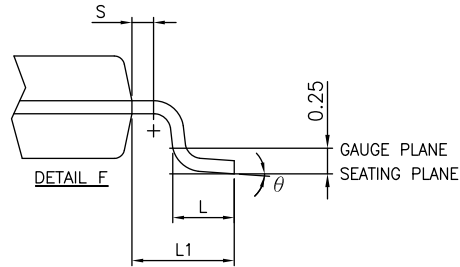
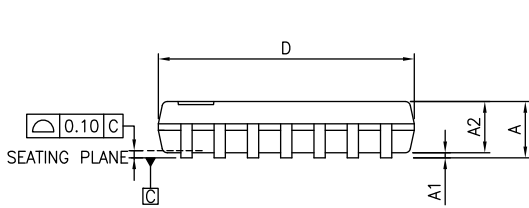

- NOTES:
 1. ALL DIMENSIONS IN MILLIMETERS. ANGLES IN DEGREES.
 2. JEDEC MO-153F
 3. DIMENSIONS DOES NOT INCLUDE MOLD FLASH, PROTRUSIONS OR GATE BURRS.

PERICOM Enabling Serial Connectivity	DATE: 03/24/16
DESCRIPTION: 14-Pin, 173mil Wide TSSOP	
PACKAGE CODE: L (L14)	
DOCUMENT CONTROL #: PD-1309	REVISION: E

16-0060

PI3B3125/PI3B3126

Packaging Mechanical: 14-SOIC (W)

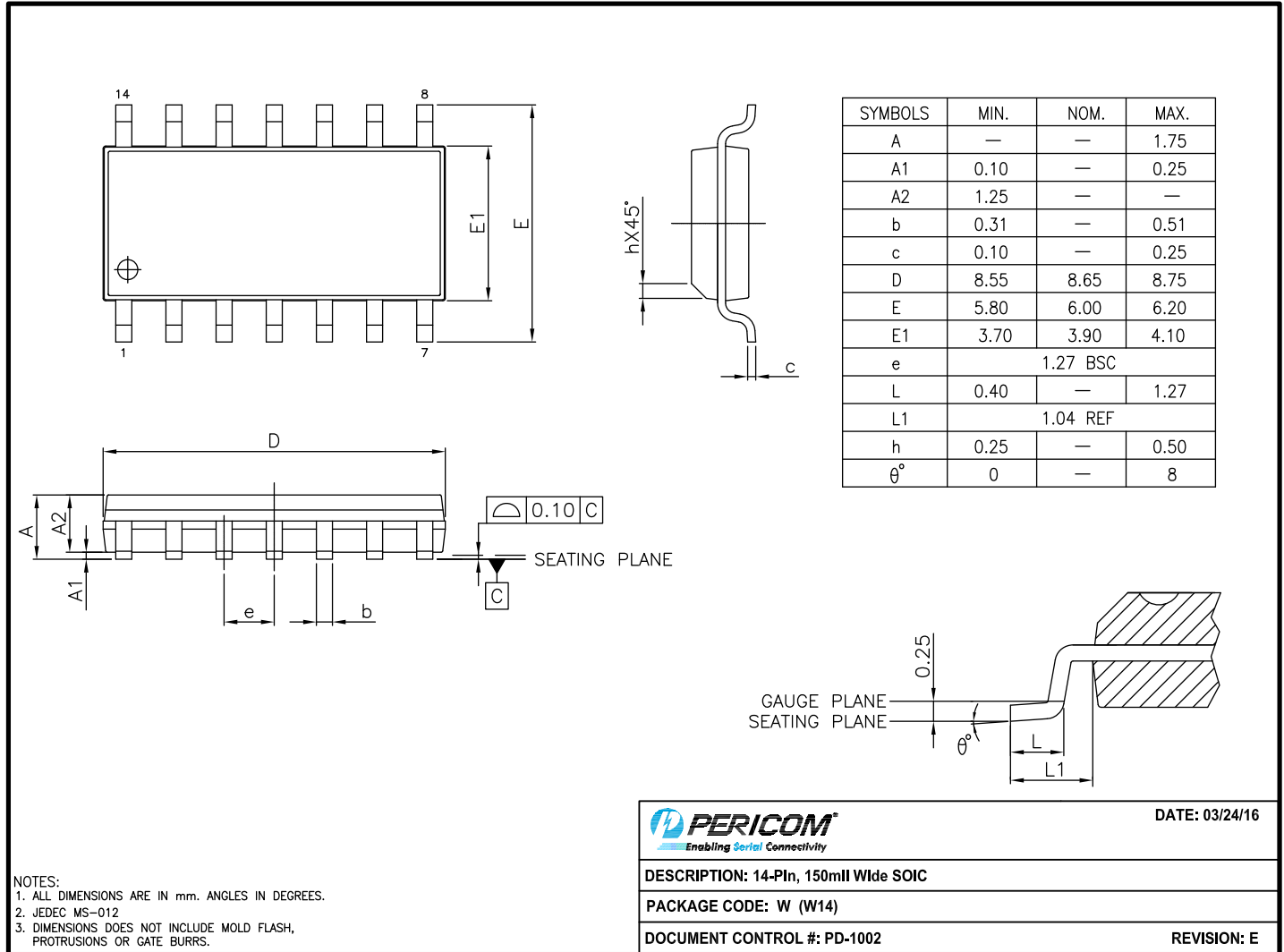

16-0055

PERICOM Enabling Serial Connectivity	DATE: 03/24/16
DESCRIPTION: 14-Pin, 150mil Wide SOIC	
PACKAGE CODE: W (W14)	
DOCUMENT CONTROL #: PD-1002	REVISION: E

PI3B3125/PI3B3126

Packaging Mechanical: 16-QSOP (Q)

SYMBOLS	MIN.	NOM.	MAX.
A	—	—	0.069
A1	0.004	—	0.0098
A2	0.049	—	—
b	0.008	—	0.012
c	0.004	—	0.010
D	0.189	0.193	0.197
E1	0.150	0.154	0.158
E	0.228	0.236	0.244
L	0.016	—	0.050
L1	0.041 REF.		
e	0.025 BSC.		
θ°	0	—	8

UNIT : INCH

NOTES:
 1. ALL DIMENSIONS IN INCH. ANGLES IN DEGREES.
 2. JEDEC MO-137E
 3. DIMENSIONS DOES NOT INCLUDE MOLD FLASH, PROTRUSIONS OR GATE BURRS.

PERICOM
Enabling Serial Connectivity

DATE: 04/08/16

DESCRIPTION: 16-Pin, 150mil Wide QSOP

PACKAGE CODE: Q (Q16)

DOCUMENT CONTROL #: PD-1201

REVISION: H

16-0056

Packaging Mechanical: 14-TQFN (ZDB)

TOP VIEW

BOTTOM VIEW

SIDE VIEW

RECOMMENDED LAND PATTERN (unit:mm)

PKG. DIMENSIONS(MM)			
SYMBOL	Min	NOM	Max
A	0.75	0.80	0.85
A1	0.00	0.02	0.05
A3	0.15 REF		
D	3.45	3.50	3.55
E	3.45	3.50	3.55
D1	1.90	2.00	2.10
E1	1.90	2.00	2.10
b	0.20	0.25	0.30
e	0.50 BSC		
e1	1.50 BSC		
L	0.35	0.40	0.45

Note:
1. Comply with JEDEC MO-220K, except 'A', 'A3', 'D1' and 'E1'.

DIODES	PERICOM	DATE: 02/15/17
DESCRIPTION: 14-Pin, TQFN, 3.5x3.5		
PACKAGE CODE: ZDB (ZDB14)		
DOCUMENT CONTROL #: PD-2222	REVISION: --	

17-0029

For latest package info.

please check: <http://www.diodes.com/design/support/packaging/pericom-packaging/packaging-mechanicals-and-thermal-characteristics/>

Ordering Information

Ordering Code	Package Code	Package Description
PI3B3125LEX	L	14-Pin, 173mil Wide (TSSOP)
PI3B3125WEX	W	14-Pin, 150mil Wide (SOIC)
PI3B3125QEX	Q	16-Pin, 150mil Wide(QSOP)
PI3B3126LEX	L	14-Pin, 173mil Wide (TSSOP)
PI3B3126WEX	W	14-Pin, 150mil Wide (SOIC)
PI3B3126QEX	Q	16-Pin, 150mil Wide(QSOP)
PI3B3126ZDBEX	ZDB	16-Pin, 3.5x3.5 (TQFN)

Notes:

- EU Directive 2002/95/EC (RoHS), 2011/65/EU (RoHS 2) & 2015/863/EU (RoHS 3) compliant. All applicable RoHS exemptions applied.
- See <http://www.diodes.com/quality/lead-free/> for more information about Diodes Incorporated's definitions of Halogen- and Antimony-free, "Green" and Lead-free. Thermal characteristics can be found on the company web site at www.diodes.com/design/support/packaging/
- E = Pb-free and Green
- X suffix = Tape/Reel

IMPORTANT NOTICE

DIODES INCORPORATED MAKES NO WARRANTY OF ANY KIND, EXPRESS OR IMPLIED, WITH REGARDS TO THIS DOCUMENT, INCLUDING, BUT NOT LIMITED TO, THE IMPLIED WARRANTIES OF MERCHANTABILITY AND FITNESS FOR A PARTICULAR PURPOSE (AND THEIR EQUIVALENTS UNDER THE LAWS OF ANY JURISDICTION).

Diodes Incorporated and its subsidiaries reserve the right to make modifications, enhancements, improvements, corrections or other changes without further notice to this document and any product described herein. Diodes Incorporated does not assume any liability arising out of the application or use of this document or any product described herein; neither does Diodes Incorporated convey any license under its patent or trademark rights, nor the rights of others. Any Customer or user of this document or products described herein in such applications shall assume all risks of such use and will agree to hold Diodes Incorporated and all the companies whose products are represented on Diodes Incorporated website, harmless against all damages.

Diodes Incorporated does not warrant or accept any liability whatsoever in respect of any products purchased through unauthorized sales channel.

Should Customers purchase or use Diodes Incorporated products for any unintended or unauthorized application, Customers shall indemnify and hold Diodes Incorporated and its representatives harmless against all claims, damages, expenses, and attorney fees arising out of, directly or indirectly, any claim of personal injury or death associated with such unintended or unauthorized application.

Products described herein may be covered by one or more United States, international or foreign patents pending. Product names and markings noted herein may also be covered by one or more United States, international or foreign trademarks.

This document is written in English but may be translated into multiple languages for reference. Only the English version of this document is the final and determinative format released by Diodes Incorporated.

LIFE SUPPORT

Diodes Incorporated products are specifically not authorized for use as critical components in life support devices or systems without the express written approval of the Chief Executive Officer of Diodes Incorporated. As used herein:

A. Life support devices or systems are devices or systems which:

1. are intended to implant into the body, or

2. support or sustain life and whose failure to perform when properly used in accordance with instructions for use provided in the labeling can be reasonably expected to result in significant injury to the user.



B. A critical component is any component in a life support device or system whose failure to perform can be reasonably expected to cause the failure of the life support device or to affect its safety or effectiveness.

Customers represent that they have all necessary expertise in the safety and regulatory ramifications of their life support devices or systems, and acknowledge and agree that they are solely responsible for all legal, regulatory and safety-related requirements concerning their products and any use of Diodes Incorporated products in such safety-critical, life support devices or systems, notwithstanding any devices- or systems-related information or support that may be provided by Diodes Incorporated. Further, Customers must fully indemnify Diodes Incorporated and its representatives against any damages arising out of the use of Diodes Incorporated products in such safety-critical, life support devices or systems.

Copyright © 2016, Diodes Incorporated
www.diodes.com

Looking for pricing, stock, or lifecycle information?

Click below to explore more details on WIN SOURCE:

-  [View PI3B3126LE on WIN SOURCE](#)
-  [Diodes Incorporated Information](#)

Optimize Your Supply Chain with WIN SOURCE Solutions

-  Global Sourcing Solution
-  Obsolete Management
-  Cost Control Management
-  Shortage Management
-  Alternative Solution
-  Excess Inventory Management