



**THE DATASHEET OF  
TS5A2066DCTR**



## TS5A2066 Dual-Channel 10-Ω SPST Analog Switch

### 1 Features

- Low ON-State Resistance (10 Ω)
- Control Inputs Are 5-V Tolerant
- Low Charge Injection
- Excellent ON-State Resistance Matching
- Low Total Harmonic Distortion (THD)
- 1.65-V to 5.5-V Single-Supply Operation
- Latch-Up Performance Exceeds 100 mA Per JESD 78, Class II
- ESD Performance Tested Per JESD 22
  - 2000-V Human-Body Model (A114-B, Class II)
  - 1000-V Charged-Device Model (C101)

### 2 Applications

- Sample-and-Hold Circuits
- Battery-Powered Equipment
- Audio and Video Signal Routing
- Communication Circuits
- Cell Phones
- Low-Voltage Data-Acquisition Systems
- PDAs

### 3 Description

The TS5A2066 device is a dual single-pole single-throw (SPST) analog switch that is designed to operate from 1.65 V to 5.5 V. This device can handle both digital and analog signals, and signals up to  $V_{CC}$  can be transmitted in either direction.

#### Device Information<sup>(1)</sup>

PART NUMBER	PACKAGE	BODY SIZE (NOM)
TS5A2066	SSOP (DCT)	2.95 mm x 2.80 mm
	VSSOP (DCU)	2.30 mm x 2.00 mm
	DSBGA (YZP)	1.25 mm x 2.25 mm

(1) For all available packages, see the orderable addendum at the end of the data sheet.

#### Functional Block Diagram

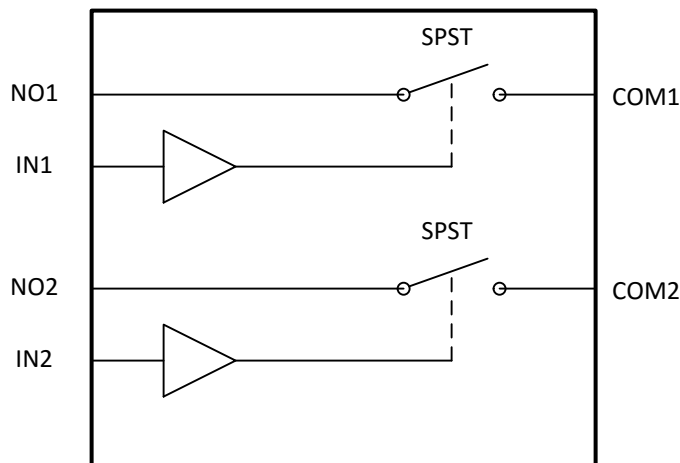

## Table of Contents

<b>1 Features</b> .....	<b>1</b>	8.2 Functional Block Diagram .....	<b>21</b>
<b>2 Applications</b> .....	<b>1</b>	8.3 Feature Description .....	<b>21</b>
<b>3 Description</b> .....	<b>1</b>	8.4 Device Functional Modes .....	<b>21</b>
<b>4 Revision History</b> .....	<b>2</b>	<b>9 Application and Implementation</b> .....	<b>22</b>
<b>5 Pin Configuration and Functions</b> .....	<b>3</b>	9.1 Application Information .....	<b>22</b>
<b>6 Specifications</b> .....	<b>4</b>	9.2 Typical Application .....	<b>22</b>
6.1 Absolute Maximum Ratings .....	<b>4</b>	<b>10 Power Supply Recommendations</b> .....	<b>23</b>
6.2 ESD Ratings .....	<b>4</b>	<b>11 Layout</b> .....	<b>24</b>
6.3 Recommended Operating Conditions .....	<b>4</b>	11.1 Layout Guidelines .....	<b>24</b>
6.4 Thermal Information .....	<b>4</b>	11.2 Layout Example .....	<b>24</b>
6.5 Electrical Characteristics For 5-V Supply .....	<b>5</b>	<b>12 Device and Documentation Support</b> .....	<b>25</b>
6.6 Electrical Characteristics For 3.3-V Supply .....	<b>7</b>	12.1 Receiving Notification of Documentation Updates .....	<b>25</b>
6.7 Electrical Characteristics For 2.5-V Supply .....	<b>9</b>	12.2 Community Resources .....	<b>25</b>
6.8 Electrical Characteristics For 1.8-V Supply .....	<b>11</b>	12.3 Trademarks .....	<b>25</b>
6.9 Typical Performance .....	<b>13</b>	12.4 Electrostatic Discharge Caution .....	<b>25</b>
<b>7 Parameter Measurement Information</b> .....	<b>16</b>	12.5 Glossary .....	<b>25</b>
<b>8 Detailed Description</b> .....	<b>21</b>	<b>13 Mechanical, Packaging, and Orderable Information</b> .....	<b>25</b>
8.1 Overview .....	<b>21</b>		

## 4 Revision History

NOTE: Page numbers for previous revisions may differ from page numbers in the current version.

<b>Changes from Revision E (June 2017) to Revision F</b>	<b>Page</b>
• Changed the YZP Package From: Top View To: Bottom View .....	<b>3</b>

<b>Changes from Revision D (April 2010) to Revision E</b>	<b>Page</b>
• Added <i>Device Information</i> table, <i>Pin Configuration and Functions</i> section, <i>ESD Ratings</i> table, <i>Recommended Operating Conditions</i> table, <i>Thermal Information</i> table, <i>Feature Description</i> section, <i>Device Functional Modes</i> , <i>Application and Implementation</i> section, <i>Power Supply Recommendations</i> section, <i>Layout</i> section, <i>Device and Documentation Support</i> section, and <i>Mechanical, Packaging, and Orderable Information</i> section .....	<b>1</b>
• Deleted the <i>Summary of Characteristics</i> table .....	<b>3</b>
• Changed pin 8 From: $V_+$ To: $V_{CC}$ in the pinout images .....	<b>3</b>
• Deleted the ON-state resistance Min values of 10 $\Omega$ and 12 $\Omega$ in the <i>Electrical Characteristics For 3.3-V Supply</i> table .....	<b>7</b>
• Deleted the ON-state resistance Min values of 20 $\Omega$ in the <i>Electrical Characteristics For 2.5-V Supply</i> table .....	<b>9</b>
• Changed Test Conditions for Charge injection From: See Figure 23 To; See Figure 24 in the <i>Electrical Characteristics For 2.5-V Supply</i> table .....	<b>10</b>
• Deleted the ON-state resistance Min values of 80 $\Omega$ and 90 $\Omega$ in the <i>Electrical Characteristics For 1.8-V Supply</i> table .....	<b>11</b>
• Changed $V_+$ to $V_{CC}$ in the <i>Typical Performance</i> graphs .....	<b>13</b>
• Changed $V_+$ to $V_{CC}$ in the <i>Parameter Measurement Information</i> images .....	<b>16</b>

## 5 Pin Configuration and Functions

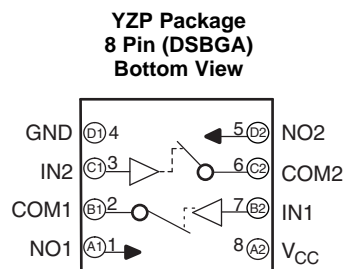
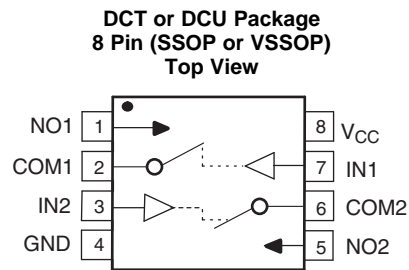

### Pin Functions

NO.	NAME	DESCRIPTION
1	NO1	Normally open
2	COM1	Common
3	IN2	Digital control to connect COM to NO
4	GND	Digital ground
5	NO2	Normally open
6	COM2	Common
7	IN1	Digital control to connect COM to NO
8	V <sub>CC</sub>	Power supply

## 6 Specifications

### 6.1 Absolute Maximum Ratings<sup>(1)(2)</sup>

over operating free-air temperature range (unless otherwise noted)

		MIN	MAX	UNIT
V <sub>CC</sub>	Supply voltage range <sup>(3)</sup>	-0.5	6.5	V
V <sub>NO</sub> V <sub>COM</sub>	Analog voltage range <sup>(3)(4)(5)</sup>	-0.5	V <sub>CC</sub> + 0.5	V
I <sub>K</sub>	Analog port diode current V <sub>NO</sub> , V <sub>COM</sub> < 0 or V <sub>NO</sub> , V <sub>COM</sub> > V <sub>CC</sub>	-50	50	mA
I <sub>NO</sub> I <sub>COM</sub>	On-state switch current V <sub>NO</sub> , V <sub>COM</sub> = 0 to V <sub>CC</sub>	-50	50	mA
V <sub>IN</sub>	Digital input voltage range <sup>(3)(4)</sup>	-0.5	6.5	V
I <sub>IK</sub>	Digital input clamp current V <sub>IN</sub> < 0	-50		mA
I <sub>CC</sub>	Continuous current through V <sub>CC</sub>		100	mA
I <sub>GND</sub>	Continuous current through GND	-100	100	mA
T <sub>stg</sub>	Storage temperature range	-65	150	°C

- (1) Stresses beyond those listed under "absolute maximum ratings" may cause permanent damage to the device. These are stress ratings only, and functional operation of the device at these or any other conditions beyond those indicated under "recommended operating conditions" is not implied. Exposure to absolute-maximum-rated conditions for extended periods may affect device reliability.
- (2) The algebraic convention, whereby the most negative value is a minimum and the most positive value is a maximum.
- (3) All voltages are with respect to ground, unless otherwise specified.
- (4) The input and output voltage ratings may be exceeded if the input and output clamp-current ratings are observed.
- (5) This value is limited to 5.5 V maximum.

### 6.2 ESD Ratings

		VALUE	UNIT
V <sub>(ESD)</sub>	Electrostatic discharge		
	Human-body model (HBM), per ANSI/ESDA/JEDEC JS-001 <sup>(1)</sup>	±2000	V
Charged-device model (CDM), per JEDEC specification JESD22-C101 <sup>(2)</sup>	±1000		

- (1) JEDEC document JEP155 states that 500-V HBM allows safe manufacturing with a standard ESD control process.
- (2) JEDEC document JEP157 states that 250-V CDM allows safe manufacturing with a standard ESD control process.

### 6.3 Recommended Operating Conditions

over operating free-air temperature range (unless otherwise noted)

		MIN	MAX	UNIT
V <sub>CC</sub>	Supply voltage range	1.65	5.5	V
V <sub>NO</sub> V <sub>COM</sub>	Analog voltage range	0	V <sub>CC</sub>	V
V <sub>IN</sub>	Digital input voltage range	0	5.5	V

### 6.4 Thermal Information

THERMAL METRIC <sup>(1)</sup>	TS5A2066			UNIT	
	DCT (SSOP)	DCU (VSSOP)	YZP (DSBGA)		
	8 PINS	8 PINS	8 PINS		
R <sub>θJA</sub>	Junction-to-ambient thermal resistance	214.1	212.8	99.8	°C/W
R <sub>θJC(top)</sub>	Junction-to-case (top) thermal resistance	106.8	93.6	1.0	°C/W
R <sub>θJB</sub>	Junction-to-board thermal resistance	127.8	133.6	29.6	°C/W
ψ <sub>JT</sub>	Junction-to-top characterization parameter	30.2	30.4	0.5	°C/W
ψ <sub>JB</sub>	Junction-to-board characterization parameter	125.5	133.1	29.8	°C/W

- (1) For more information about traditional and new thermal metrics, see the [Semiconductor and IC Package Thermal Metrics](#) application report.

## 6.5 Electrical Characteristics For 5-V Supply<sup>(1)</sup>

 $V_{CC} = 4.5\text{ V to }5.5\text{ V}$ ,  $T_A = -40^\circ\text{C to }85^\circ\text{C}$  (unless otherwise noted)

PARAMETER	SYMBOL	TEST CONDITIONS	$T_A$	$V_{CC}$	MIN	TYP	MAX	UNIT
<b>Analog Switch</b>								
Analog signal range	$V_{COM}, V_{NO}$				0		$V_{CC}$	V
ON-state resistance	$r_{on}$	$0 \leq V_{NO} \leq V_{CC}$ , $I_{COM} = -32\text{ mA}$ , Switch ON, See <a href="#">Figure 16</a>	25°C Full	4.5 V		7.5	10 15	$\Omega$
ON-state resistance match between channels	$\Delta r_{on}$	$V_{NO} = 3.15\text{ V}$ , $I_{COM} = -32\text{ mA}$ , Switch ON, See <a href="#">Figure 16</a>	25°C Full	4.5 V		0.4	1 3	$\Omega$
ON-state resistance flatness	$r_{on(Flat)}$	$0 \leq V_{NO} \leq V_{CC}$ , $I_{COM} = -32\text{ mA}$ , Switch ON, See <a href="#">Figure 16</a>	25°C Full	4.5 V		3.5	5 8	$\Omega$
NO OFF leakage current	$I_{NO(OFF)}$	$V_{NO} = 1\text{ V}$ , $V_{COM} = 4.5\text{ V}$ , or $V_{NO} = 4.5\text{ V}$ , $V_{COM} = 1\text{ V}$ , Switch OFF, See <a href="#">Figure 17</a>	25°C Full	5.5 V	-30	-10	30 40	nA
COM OFF leakage current	$I_{COM(OFF)}$	$V_{COM} = 1\text{ V}$ , $V_{NO} = 4.5\text{ V}$ , or $V_{COM} = 4.5\text{ V}$ , $V_{NO} = 1\text{ V}$ , Switch OFF, See <a href="#">Figure 17</a>	25°C Full	5.5 V	-50	-8	50 50	nA
NO ON leakage current	$I_{NO(ON)}$	$V_{NO} = 1\text{ V}$ , $V_{COM} = \text{Open}$ , or $V_{NO} = 4.5\text{ V}$ , $V_{COM} = \text{Open}$ , Switch ON, See <a href="#">Figure 18</a>	25°C Full	5.5 V	-40	-12	40 40	nA
COM ON leakage current	$I_{COM(ON)}$	$V_{COM} = 1\text{ V}$ , $V_{NO} = \text{Open}$ , or $V_{COM} = 4.5\text{ V}$ , $V_{NO} = \text{Open}$ , Switch ON, See <a href="#">Figure 18</a>	25°C Full	5.5 V	-70	-30	70 70	nA
<b>Digital Control Input (IN)</b>								
Input logic high	$V_{IH}$		Full		$V_{CC} \times 0.7$		5.5	V
Input logic low	$V_{IL}$		Full		0		$V_{CC} \times 0.3$	V
Input leakage current	$I_{IH}, I_{IL}$	$V_{IN} = 5.5\text{ V or }0$	25°C Full	5.5 V	-0.1	0.05	0.1 1	$\mu\text{A}$

(1) The algebraic convention, whereby the most negative value is a minimum and the most positive value is a maximum.

**Electrical Characteristics For 5-V Supply<sup>(1)</sup> (continued)**
 $V_{CC} = 4.5\text{ V to }5.5\text{ V}$ ,  $T_A = -40^\circ\text{C to }85^\circ\text{C}$  (unless otherwise noted)

PARAMETER	SYMBOL	TEST CONDITIONS	$T_A$	$V_{CC}$	MIN	TYP	MAX	UNIT	
<b>Dynamic</b>									
Turn-on time	$t_{ON}$	$V_{COM} = 3\text{ V}$ , $R_L = 300\ \Omega$ ,	$C_L = 35\text{ pF}$ , See <a href="#">Figure 20</a>	25°C	5 V	4.4	5.2	5.8	ns
				Full	4.5 V to 5.5 V	3.4		6.1	
Turn-off time	$t_{OFF}$	$V_{COM} = 3\text{ V}$ , $R_L = 300\ \Omega$ ,	$C_L = 35\text{ pF}$ , See <a href="#">Figure 20</a>	25°C	5 V	1.7	2.6	3.6	ns
				Full	4.5 V to 5.5 V	1.3		4.2	
Charge injection	$Q_C$	$V_{GEN} = 0$ , $R_{GEN} = 0$ ,	$C_L = 0.1\text{ nF}$ , See <a href="#">Figure 24</a>	25°C	5 V		1	pC	
NO OFF capacitance	$C_{NO(OFF)}$	$V_{NO} = V_{CC}$ or GND,	Switch OFF, See <a href="#">Figure 19</a>	25°C	5 V		5.5	pF	
COM OFF capacitance	$C_{COM(OFF)}$	$V_{COM} = V_{CC}$ or GND,	Switch OFF, See <a href="#">Figure 19</a>	25°C	5 V		5.5	pF	
NO ON capacitance	$C_{NO(ON)}$	$V_{NO} = V_{CC}$ or GND,	Switch ON, See <a href="#">Figure 19</a>	25°C	5 V		13.5	pF	
COM ON capacitance	$C_{COM(ON)}$	$V_{COM} = V_{CC}$ or GND,	Switch ON, See <a href="#">Figure 19</a>	25°C	5 V		13.5	pF	
Digital input capacitance	$C_{IN}$	$V_{IN} = V_{CC}$ or GND,	See <a href="#">Figure 19</a>	25°C	5 V		2.5	pF	
Bandwidth	BW	$R_L = 50\ \Omega$ ,	Switch ON, See <a href="#">Figure 21</a>	25°C	5 V		300	MHz	
OFF isolation	$O_{ISO}$	$R_L = 50\ \Omega$ , $f = 10\text{ MHz}$ ,	Switch OFF, See <a href="#">Figure 22</a>	25°C	5 V		-68	dB	
Crosstalk	$X_{TALK}$	$R_L = 50\ \Omega$ , $f = 10\text{ MHz}$ ,	Switch ON, See <a href="#">Figure 23</a>	25°C	5 V		-66	dB	
Total harmonic distortion	THD	$R_L = 600\ \Omega$ , $C_L = 50\text{ pF}$ ,	$f = 20\text{ Hz to }20\text{ kHz}$ , See <a href="#">Figure 25</a>	25°C	5 V		0.01%		
<b>Supply</b>									
Positive supply current	$I_{CC}$	$V_{IN} = V_{CC}$ or GND,	Switch ON or OFF	25°C	5.5 V		0.1	1	$\mu\text{A}$
				Full				5	

## 6.6 Electrical Characteristics For 3.3-V Supply<sup>(1)</sup>

 $V_{CC} = 3\text{ V to }3.6\text{ V}$ ,  $T_A = -40^\circ\text{C to }85^\circ\text{C}$  (unless otherwise noted)

PARAMETER	SYMBOL	TEST CONDITIONS	$T_A$	$V_{CC}$	MIN	TYP	MAX	UNIT
<b>Analog Switch</b>								
Analog signal range	$V_{COM}, V_{NO}$				0		$V_{CC}$	V
ON-state resistance	$r_{on}$	$0 \leq V_{NO} \leq V_{CC}$ , $I_{COM} = -24\text{ mA}$ , Switch ON, See <a href="#">Figure 16</a>	25°C	3 V		12	15	$\Omega$
			Full				20	
ON-state resistance match between channels	$\Delta r_{on}$	$V_{NO} = 2.1\text{ V}$ , $I_{COM} = -24\text{ mA}$ , Switch ON, See <a href="#">Figure 16</a>	25°C	3 V		0.5	1.5	$\Omega$
			Full					
ON-state resistance flatness	$r_{on(Flat)}$	$0 \leq V_{NO} \leq V_{CC}$ , $I_{COM} = -24\text{ mA}$ , Switch ON, See <a href="#">Figure 16</a>	25°C	3 V		7	8	$\Omega$
			Full					
NO OFF leakage current	$I_{NO(OFF)}$	$V_{NO} = 1\text{ V}$ , $V_{COM} = 3\text{ V}$ , or $V_{NO} = 3\text{ V}$ , $V_{COM} = 1\text{ V}$ , Switch OFF, See <a href="#">Figure 17</a>	25°C	3.6 V		-30	-6	30
			Full					
COM OFF leakage current	$I_{COM(OFF)}$	$V_{COM} = 1\text{ V}$ , $V_{NO} = 3\text{ V}$ , or $V_{COM} = 3\text{ V}$ , $V_{NO} = 1\text{ V}$ , Switch OFF, See <a href="#">Figure 17</a>	25°C	3.6 V		-50	-7	50
			Full					
NO ON leakage current	$I_{NO(ON)}$	$V_{NO} = 1\text{ V}$ , $V_{COM} = \text{Open}$ , or $V_{NO} = 3\text{ V}$ , $V_{COM} = \text{Open}$ , Switch ON, See <a href="#">Figure 18</a>	25°C	3.6 V		-40	-7	40
			Full					
COM ON leakage current	$I_{COM(ON)}$	$V_{COM} = 1\text{ V}$ , $V_{NO} = \text{Open}$ , or $V_{COM} = 3\text{ V}$ , $V_{NO} = \text{Open}$ , Switch ON, See <a href="#">Figure 18</a>	25°C	3.6 V		-70	-20	70
			Full					
<b>Digital Control Input (IN)</b>								
Input logic high	$V_{IH}$		Full		$V_{CC} \times 0.7$		5.5	V
Input logic low	$V_{IL}$		Full		0		$V_{CC} \times 0.3$	V
Input leakage current	$I_{IH}, I_{IL}$	$V_{IN} = 5.5\text{ V or }0$	25°C	3.6 V		-0.1	0.05	0.1
			Full					

(1) The algebraic convention, whereby the most negative value is a minimum and the most positive value is a maximum.

**Electrical Characteristics For 3.3-V Supply<sup>(1)</sup> (continued)**
 $V_{CC} = 3\text{ V to }3.6\text{ V}$ ,  $T_A = -40^\circ\text{C to }85^\circ\text{C}$  (unless otherwise noted)

PARAMETER	SYMBOL	TEST CONDITIONS	$T_A$	$V_{CC}$	MIN	TYP	MAX	UNIT	
<b>Dynamic</b>									
Turn-on time	$t_{ON}$	$V_{COM} = 2\text{ V}$ , $R_L = 300\ \Omega$ ,	$C_L = 35\text{ pF}$ , See <a href="#">Figure 20</a>	25°C	3.3 V	4.9	5.6	6.4	ns
				Full	3 V to 3.6 V	4.3		7.1	
Turn-off time	$t_{OFF}$	$V_{COM} = 2\text{ V}$ , $R_L = 300\ \Omega$ ,	$C_L = 35\text{ pF}$ , See <a href="#">Figure 20</a>	25°C	3.3 V	2	2.7	3.7	ns
				Full	3 V to 3.6 V	1.3		4.7	
Charge injection	$Q_C$	$V_{GEN} = 0$ , $R_{GEN} = 0$ ,	$C_L = 0.1\text{ nF}$ , See <a href="#">Figure 24</a>	25°C	3.3 V		0.5	pC	
NO OFF capacitance	$C_{NO(OFF)}$	$V_{NO} = V_{CC}$ or GND,	Switch OFF, See <a href="#">Figure 19</a>	25°C	3.3 V		5.5	pF	
COM OFF capacitance	$C_{COM(OFF)}$	$V_{COM} = V_{CC}$ or GND,	Switch OFF, See <a href="#">Figure 19</a>	25°C	3.3 V		6	pF	
NO ON capacitance	$C_{NO(ON)}$	$V_{NO} = V_{CC}$ or GND,	Switch ON, See <a href="#">Figure 19</a>	25°C	3.3 V		14	pF	
COM ON capacitance	$C_{COM(ON)}$	$V_{COM} = V_{CC}$ or GND,	Switch ON, See <a href="#">Figure 19</a>	25°C	3.3 V		14	pF	
Digital input capacitance	$C_I$	$V_{IN} = V_{CC}$ or GND,	See <a href="#">Figure 19</a>	25°C	3.3 V		3	pF	
Bandwidth	BW	$R_L = 50\ \Omega$ ,	Switch ON, See <a href="#">Figure 21</a>	25°C	3.3 V		300	MHz	
OFF isolation	$O_{ISO}$	$R_L = 50\ \Omega$ , $f = 10\text{ MHz}$ ,	Switch OFF, See <a href="#">Figure 22</a>	25°C	3.3 V		-68	dB	
Crosstalk	$X_{TALK}$	$R_L = 50\ \Omega$ , $f = 10\text{ MHz}$ ,	Switch ON, See <a href="#">Figure 23</a>	25°C	3.3 V		-66	dB	
Total harmonic distortion	THD	$R_L = 600\ \Omega$ , $C_L = 50\text{ pF}$ ,	$f = 20\text{ Hz to }20\text{ kHz}$ , See <a href="#">Figure 25</a>	25°C	3.3 V		0.065%		
<b>Supply</b>									
Positive supply current	$I_{CC}$	$V_{IN} = V_{CC}$ or GND,	Switch ON or OFF	25°C	3.6 V	0.1		1	$\mu\text{A}$
				Full				5	

## 6.7 Electrical Characteristics For 2.5-V Supply<sup>(1)</sup>

 $V_{CC} = 2.3 \text{ V to } 2.7 \text{ V}$ ,  $T_A = -40^\circ\text{C to } 85^\circ\text{C}$  (unless otherwise noted)

PARAMETER	SYMBOL	TEST CONDITIONS	$T_A$	$V_{CC}$	MIN	TYP	MAX	UNIT
<b>Analog Switch</b>								
Analog signal range	$V_{COM}, V_{NO}$				0		$V_{CC}$	V
ON-state resistance	$r_{on}$	$0 \leq V_{NO} \leq V_{CC}$ , $I_{COM} = -8 \text{ mA}$ , Switch ON, See <a href="#">Figure 16</a>	25°C	2.3 V	22		30	$\Omega$
			Full					
ON-state resistance match between channels	$\Delta r_{on}$	$V_{NO} = 1.6 \text{ V}$ , $I_{COM} = -8 \text{ mA}$ , Switch ON, See <a href="#">Figure 16</a>	25°C	2.3 V	0.5		1.5	$\Omega$
			Full				5	
ON-state resistance flatness	$r_{on(Flat)}$	$0 \leq V_{NO} \leq V_{CC}$ , $I_{COM} = -8 \text{ mA}$ , Switch ON, See <a href="#">Figure 16</a>	25°C	2.3 V	16		18	$\Omega$
			Full				25	
NO OFF leakage current	$I_{NO(OFF)}$	$V_{NO} = 0.5 \text{ V}$ , $V_{COM} = 2.2 \text{ V}$ , or $V_{NO} = 2.2 \text{ V}$ , $V_{COM} = 0.5 \text{ V}$ , Switch OFF, See <a href="#">Figure 17</a>	25°C	2.7 V	-30	-5.5	30	nA
			Full		-40		40	
COM OFF leakage current	$I_{COM(OFF)}$	$V_{COM} = 0.5 \text{ V}$ , $V_{NO} = 2.2 \text{ V}$ , or $V_{COM} = 2.2 \text{ V}$ , $V_{NO} = 0.5 \text{ V}$ , Switch OFF, See <a href="#">Figure 17</a>	25°C	2.7 V	-50	-7.5	50	nA
			Full		-50		50	
NO ON leakage current	$I_{NO(ON)}$	$V_{NO} = 0.5 \text{ V}$ , $V_{COM} = \text{Open}$ , or $V_{NO} = 2.2 \text{ V}$ , $V_{COM} = \text{Open}$ , Switch ON, See <a href="#">Figure 18</a>	25°C	2.7 V	-40	-5	40	nA
			Full		-40		40	
COM ON leakage current	$I_{COM(ON)}$	$V_{COM} = 0.5 \text{ V}$ , $V_{NO} = \text{Open}$ , or $V_{COM} = 2.2 \text{ V}$ , $V_{NO} = \text{Open}$ , Switch ON, See <a href="#">Figure 18</a>	25°C	2.7 V	-70	-12	70	nA
			Full		-70		70	
<b>Digital Control Input (IN)</b>								
Input logic high	$V_{IH}$		Full		$V_{CC} \times 0.7$		5.5	V
Input logic low	$V_{IL}$		Full		0	$V_{CC} \times 0.3$		V
Input leakage current	$I_{IH}, I_{IL}$	$V_{IN} = 5.5 \text{ V or } 0$	25°C	2.7 V	-0.1	0.05	0.1	$\mu\text{A}$
			Full		-1		1	

(1) The algebraic convention, whereby the most negative value is a minimum and the most positive value is a maximum.

**Electrical Characteristics For 2.5-V Supply<sup>(1)</sup> (continued)**
 $V_{CC} = 2.3 \text{ V to } 2.7 \text{ V}$ ,  $T_A = -40^\circ\text{C to } 85^\circ\text{C}$  (unless otherwise noted)

PARAMETER	SYMBOL	TEST CONDITIONS	$T_A$	$V_{CC}$	MIN	TYP	MAX	UNIT
<b>Dynamic</b>								
Turn-on time	$t_{ON}$	$V_{COM} = 1.5 \text{ V}$ , $R_L = 300 \Omega$ , See <a href="#">Figure 20</a>	25°C	2.5 V	5.7	6.4	8.1	ns
			Full	2.3 V to 2.7 V	4.4		8.5	
Turn-off time	$t_{OFF}$	$V_{COM} = 1.5 \text{ V}$ , $R_L = 300 \Omega$ , See <a href="#">Figure 20</a>	25°C	2.5 V	2.1	3.1	4.3	ns
			Full	2.3 V to 2.7 V	1.8		4.8	
Charge injection	$Q_C$	$V_{GEN} = 0$ , $R_{GEN} = 0$ , $C_L = 0.1 \text{ nF}$ , See <a href="#">Figure 24</a>	25°C	2.5 V		0.5		pC
NO OFF capacitance	$C_{NO(OFF)}$	$V_{NO} = V_{CC}$ or GND, Switch OFF, See <a href="#">Figure 19</a>	25°C	2.5 V		6		pF
COM OFF capacitance	$C_{COM(OFF)}$	$V_{COM} = V_{CC}$ or GND, Switch OFF, See <a href="#">Figure 19</a>	25°C	2.5 V		6		pF
NO ON capacitance	$C_{NO(ON)}$	$V_{NO} = V_{CC}$ or GND, Switch ON, See <a href="#">Figure 19</a>	25°C	2.5 V		14		pF
COM ON capacitance	$C_{COM(ON)}$	$V_{COM} = V_{CC}$ or GND, Switch ON, See <a href="#">Figure 19</a>	25°C	2.5 V		14		pF
Digital input capacitance	$C_{IN}$	$V_{IN} = V_{CC}$ or GND, See <a href="#">Figure 19</a>	25°C	2.5 V		3		pF
Bandwidth	BW	$R_L = 50 \Omega$ , Switch ON, See <a href="#">Figure 21</a>	25°C	2.5 V		300		MHz
OFF isolation	$O_{ISO}$	$R_L = 50 \Omega$ , $f = 10 \text{ MHz}$ , Switch OFF, See <a href="#">Figure 22</a>	25°C	2.5 V		-68		dB
Crosstalk	$X_{TALK}$	$R_L = 50 \Omega$ , $f = 10 \text{ MHz}$ , Switch ON, See <a href="#">Figure 23</a>	25°C	2.5 V		-66		dB
Total harmonic distortion	THD	$R_L = 600 \Omega$ , $C_L = 50 \text{ pF}$ , $f = 20 \text{ Hz to } 20 \text{ kHz}$ , See <a href="#">Figure 25</a>	25°C	2.5 V		0.35%		
<b>Supply</b>								
Positive supply current	$I_{CC}$	$V_{IN} = V_{CC}$ or GND, Switch ON or OFF	25°C	2.7 V	0.1		1	$\mu\text{A}$
			Full				5	

## 6.8 Electrical Characteristics For 1.8-V Supply<sup>(1)</sup>

 $V_{CC} = 1.65\text{ V to }1.95\text{ V}$ ,  $T_A = -40^\circ\text{C to }85^\circ\text{C}$  (unless otherwise noted)

PARAMETER	SYMBOL	TEST CONDITIONS	$T_A$	$V_{CC}$	MIN	TYP	MAX	UNIT	
<b>Analog Switch</b>									
Analog signal range	$V_{COM}, V_{NO}$				0		$V_{CC}$	V	
ON-state resistance	$r_{on}$	$0 \leq V_{NO} \leq V_{CC}$ , $I_{COM} = -4\text{ mA}$ ,	Switch ON, See <a href="#">Figure 16</a>	25°C	1.65 V	85		$\Omega$	
				Full		120			
ON-state resistance match between channels	$\Delta r_{on}$	$V_{NO} = 1.15\text{ V}$ , $I_{COM} = -4\text{ mA}$ ,	Switch ON, See <a href="#">Figure 16</a>	25°C	1.65 V	0.9		$\Omega$	
				Full		2			
ON-state resistance flatness	$r_{on(Flat)}$	$0 \leq V_{NO} \leq V_{CC}$ , $I_{COM} = -4\text{ mA}$ ,	Switch ON, See <a href="#">Figure 16</a>	25°C	1.65 V	75		$\Omega$	
				Full		85			
NO OFF leakage current	$I_{NO(OFF)}$	$V_{NO} = 0.3\text{ V}$ , $V_{COM} = 1.65\text{ V}$ , or $V_{NO} = 1.65\text{ V}$ , $V_{COM} = 0.3\text{ V}$ ,	Switch OFF, See <a href="#">Figure 17</a>	25°C	1.95 V	-30	-6	30	nA
				Full		-40		40	
COM OFF leakage current	$I_{COM(OFF)}$	$V_{COM} = 0.3\text{ V}$ , $V_{NO} = 1.65\text{ V}$ , or $V_{COM} = 1.65\text{ V}$ , $V_{NO} = 0.3\text{ V}$ ,	Switch OFF, See <a href="#">Figure 17</a>	25°C	1.95 V	-50	-7	50	nA
				Full		-50		50	
NO ON leakage current	$I_{NO(ON)}$	$V_{NO} = 0.3\text{ V}$ , $V_{COM} = \text{Open}$ , or $V_{NO} = 1.65\text{ V}$ , $V_{COM} = \text{Open}$ ,	Switch ON, See <a href="#">Figure 18</a>	25°C	1.95 V	-40	7	40	nA
				Full		-40		40	
COM ON leakage current	$I_{COM(ON)}$	$V_{COM} = 0.3\text{ V}$ , $V_{NO} = \text{Open}$ , or $V_{COM} = 1.65\text{ V}$ , $V_{NO} = \text{Open}$ ,	Switch ON, See <a href="#">Figure 18</a>	25°C	1.95 V	-70	-8.5	70	nA
				Full		-70		70	
<b>Digital Control Input (IN)</b>									
Input logic high	$V_{IH}$		Full		$V_{CC} \times 0.65$		5.5	V	
Input logic low	$V_{IL}$		Full		0		$V_{CC} \times 0.35$	V	
Input leakage current	$I_{IH}, I_{IL}$	$V_{IN} = 5.5\text{ V or }0$	25°C	1.95 V	-0.1	0.05	0.1	$\mu\text{A}$	
			Full		-1		1		

(1) The algebraic convention, whereby the most negative value is a minimum and the most positive value is a maximum.

**Electrical Characteristics For 1.8-V Supply<sup>(1)</sup> (continued)**
 $V_{CC} = 1.65\text{ V to }1.95\text{ V}$ ,  $T_A = -40^\circ\text{C to }85^\circ\text{C}$  (unless otherwise noted)

PARAMETER	SYMBOL	TEST CONDITIONS	$T_A$	$V_{CC}$	MIN	TYP	MAX	UNIT	
<b>Dynamic</b>									
Turn-on time	$t_{ON}$	$V_{COM} = 1.3\text{ V}$ , $R_L = 300\ \Omega$ , $C_L = 35\text{ pF}$ , See <a href="#">Figure 20</a>	25°C	1.8 V	9.3	10.4	11.5	ns	
			Full	1.65 V to 1.95 V	6.8		12.9		
Turn-off time	$t_{OFF}$	$V_{COM} = 1.3\text{ V}$ , $R_L = 300\ \Omega$ , $C_L = 35\text{ pF}$ , See <a href="#">Figure 20</a>	25°C	1.8 V	3.3	4.3	5.2	ns	
			Full	1.65 V to 1.95 V	2.4		6.5		
Charge injection	$Q_C$	$V_{GEN} = 0$ , $R_{GEN} = 0$ , $C_L = 0.1\text{ nF}$ , See <a href="#">Figure 24</a>	25°C	1.8 V		0.5		pC	
NO OFF capacitance	$C_{NO(OFF)}$	$V_{NO} = V_{CC}$ or GND, Switch OFF, See <a href="#">Figure 19</a>	25°C	1.8 V		6		pF	
COM OFF capacitance	$C_{COM(OFF)}$	$V_{COM} = V_{CC}$ or GND, Switch OFF, See <a href="#">Figure 19</a>	25°C	1.8 V		6		pF	
NO ON capacitance	$C_{NO(ON)}$	$V_{NO} = V_{CC}$ or GND, Switch ON, See <a href="#">Figure 19</a>	25°C	1.8 V		14.5		pF	
COM ON capacitance	$C_{COM(ON)}$	$V_{COM} = V_{CC}$ or GND, Switch ON, See <a href="#">Figure 19</a>	25°C	1.8 V		14.5		pF	
Digital input capacitance	$C_{IN}$	$V_{IN} = V_{CC}$ or GND, See <a href="#">Figure 19</a>	25°C	1.8 V		3		pF	
Bandwidth	BW	$R_L = 50\ \Omega$ , Switch ON, See <a href="#">Figure 21</a>	25°C	1.8 V		293		MHz	
OFF isolation	$O_{ISO}$	$R_L = 50\ \Omega$ , $f = 10\text{ MHz}$ , Switch OFF, See <a href="#">Figure 22</a>	25°C	1.8 V		-68		dB	
Crosstalk	$X_{TALK}$	$R_L = 50\ \Omega$ , $f = 10\text{ MHz}$ , Switch ON, See <a href="#">Figure 23</a>	25°C	1.8 V		-66		dB	
Total harmonic distortion	THD	$R_L = 10\text{ k}\Omega$ , $C_L = 50\text{ pF}$ , $f = 20\text{ Hz to }20\text{ kHz}$ , See <a href="#">Figure 25</a>	25°C	1.8 V		2.7%			
<b>Supply</b>									
Positive supply current	$I_{CC}$	$V_{IN} = V_{CC}$ or GND, Switch ON or OFF	25°C	1.95 V	0.1			1	$\mu\text{A}$
			Full					5	

## 6.9 Typical Performance

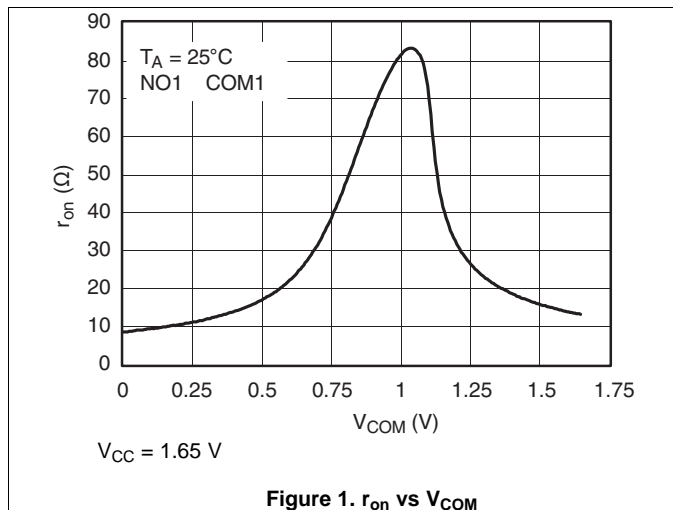

Figure 1.  $r_{on}$  vs  $V_{COM}$

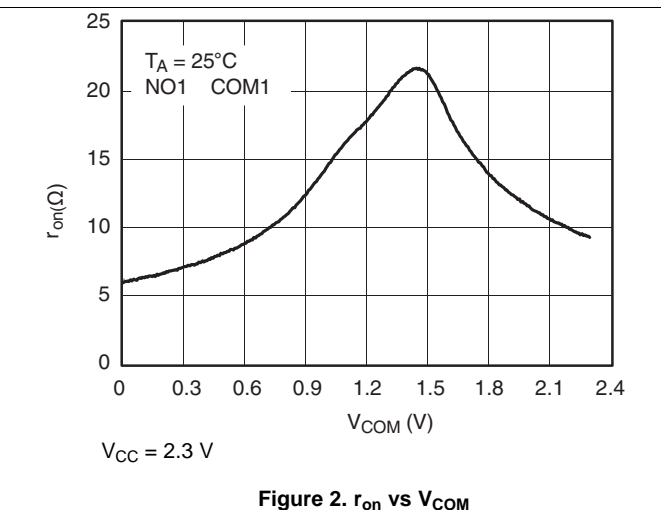

Figure 2.  $r_{on}$  vs  $V_{COM}$

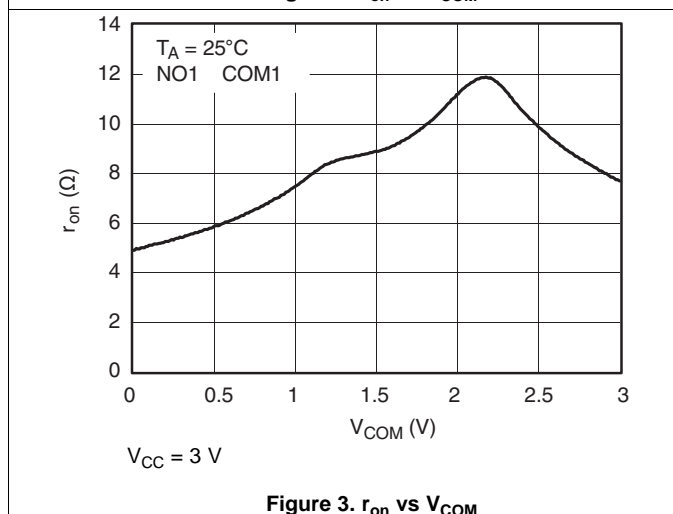

Figure 3.  $r_{on}$  vs  $V_{COM}$

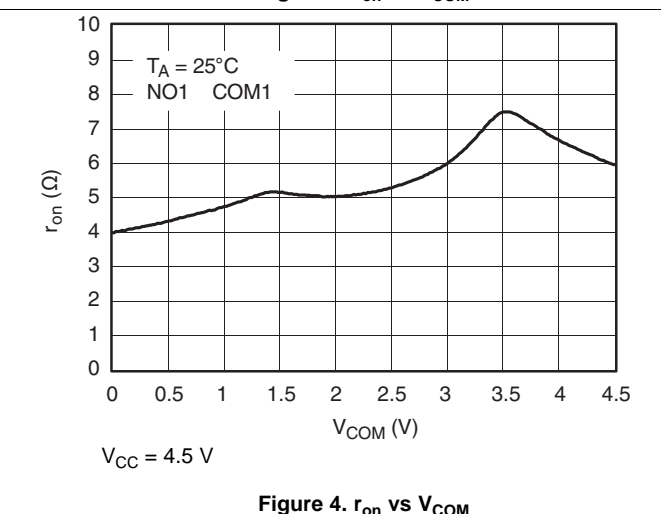

Figure 4.  $r_{on}$  vs  $V_{COM}$

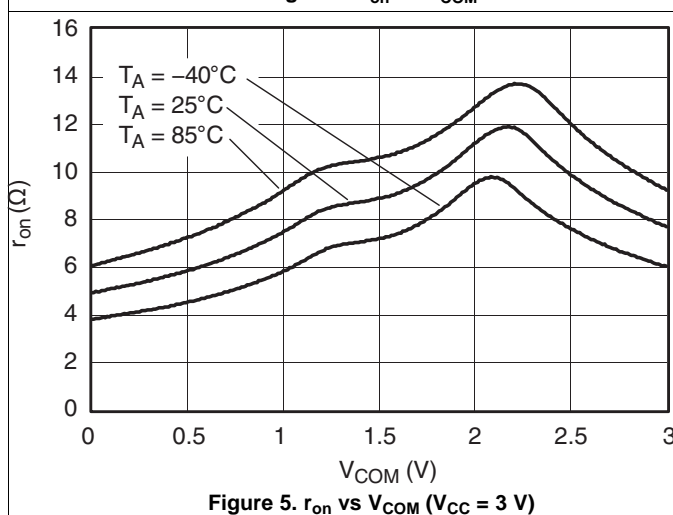

Figure 5.  $r_{on}$  vs  $V_{COM}$  ( $V_{CC} = 3$  V)

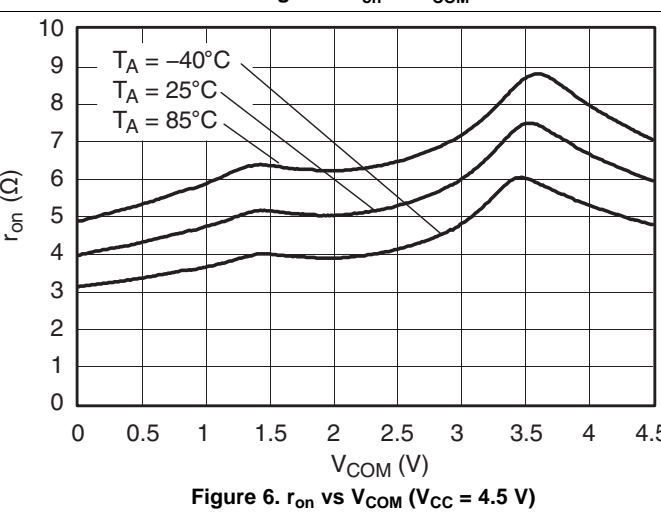

Figure 6.  $r_{on}$  vs  $V_{COM}$  ( $V_{CC} = 4.5$  V)

Typical Performance (continued)

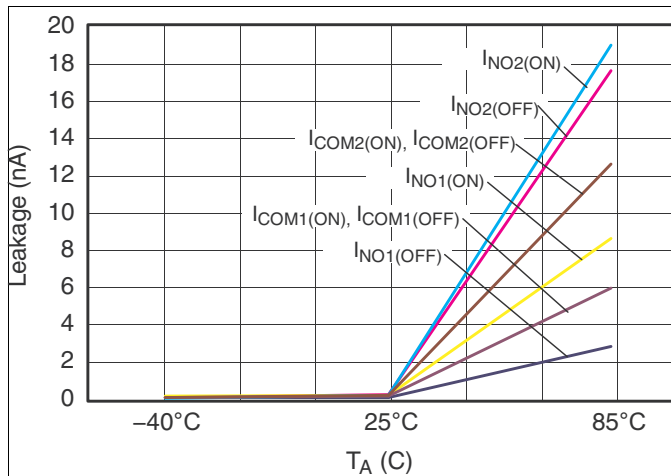

Figure 7. Leakage Current vs Temperature

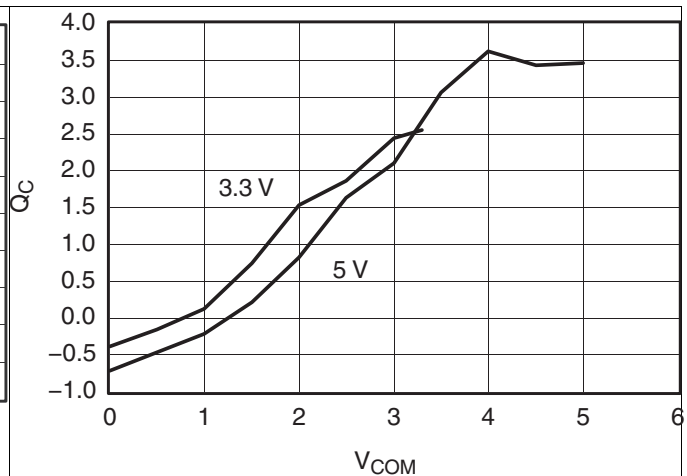

Figure 8. Charge Injection (QC) vs VCOM

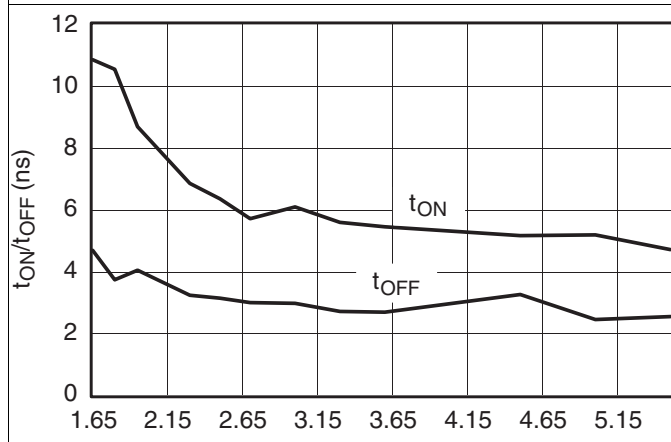

Figure 9. tON and tOFF vs VCC

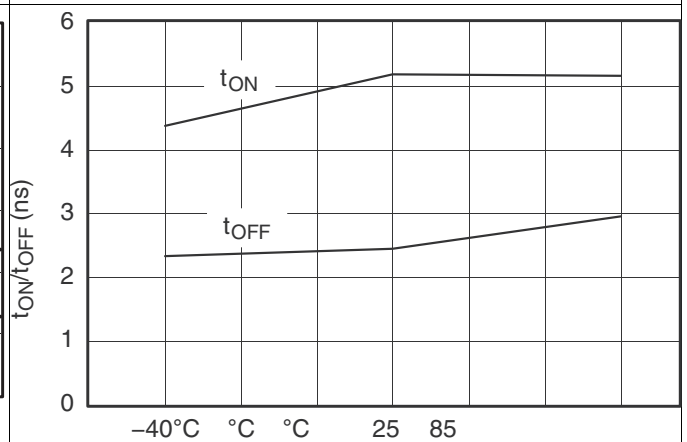

Figure 10. tON and tOFF vs Temperature (VCC = 5 V)

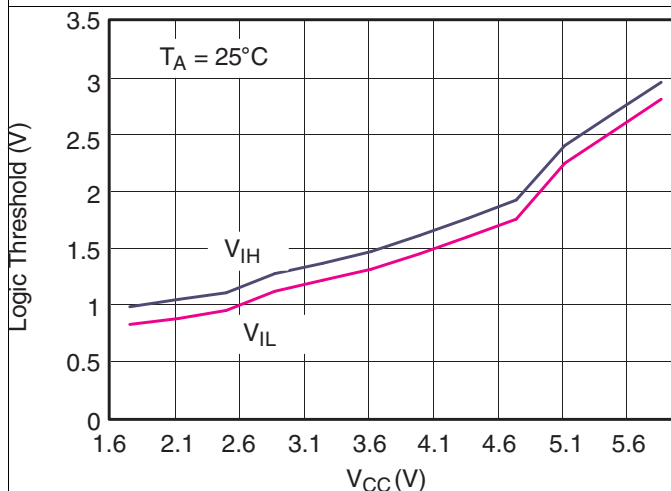

Figure 11. Logic Threshold vs VCC

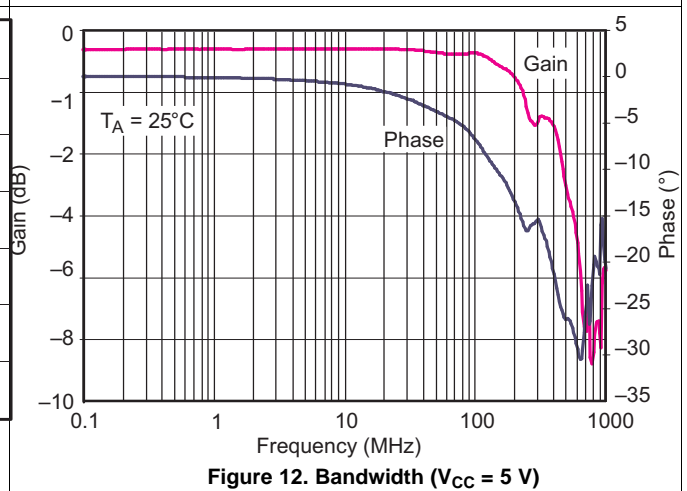

Figure 12. Bandwidth (VCC = 5 V)

Typical Performance (continued)

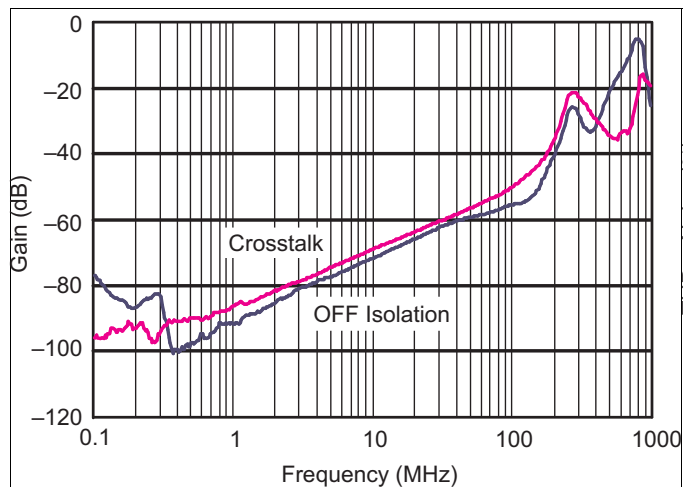

Figure 13. OFF Isolation and Crosstalk ( $V_{CC} = 5\text{ V}$ )

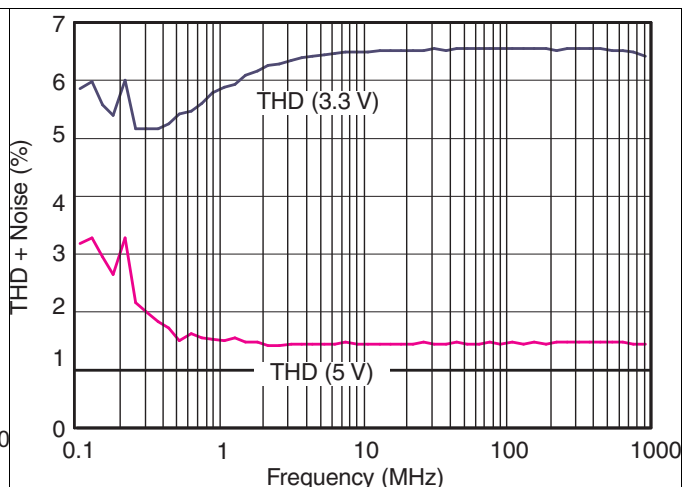

Figure 14. Total Harmonic Distortion vs Frequency

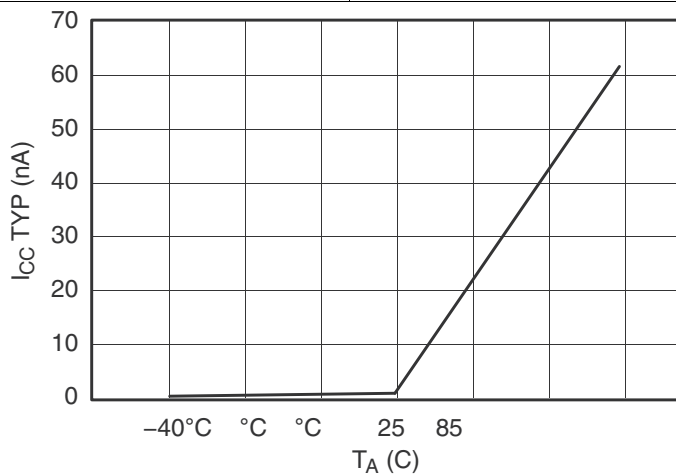

Figure 15. Power-Supply Current vs Temperature ( $V_{CC} = 5\text{ V}$ )

## 7 Parameter Measurement Information

**Table 1. Parameter Description**

SYMBOL	DESCRIPTION
$V_{COM}$	Voltage at COM
$V_{NO}$	Voltage at NO
$r_{on}$	Resistance between COM and NO ports when the channel is ON
$\Delta r_{on}$	Difference of $r_{on}$ between channels in a specific device
$r_{on(Flat)}$	Difference between the maximum and minimum value of $r_{on}$ in a channel over the specified range of conditions
$I_{NO(OFF)}$	Leakage current measured at the NO port, with the corresponding channel (NO to COM) in the OFF state
$I_{NO(ON)}$	Leakage current measured at the NO port, with the corresponding channel (NO to COM) in the ON state and the output (COM) open
$I_{COM(OFF)}$	Leakage current measured at the COM port, with the corresponding channel (COM to NO) in the OFF state
$I_{COM(ON)}$	Leakage current measured at the COM port, with the corresponding channel (COM to NO) in the ON state and the output (NO) open
$V_{IH}$	Minimum input voltage for logic high for the control input (IN)
$V_{IL}$	Maximum input voltage for logic low for the control input (IN)
$V_{IN}$	Voltage at the control input (IN)
$I_{IH}, I_{IL}$	Leakage current measured at the control input (IN)
$t_{ON}$	Turn-on time for the switch. This parameter is measured under the specified range of conditions and by the propagation delay between the digital control (IN) signal and analog output (COM or NO) signal when the switch is turning ON.
$t_{OFF}$	Turn-off time for the switch. This parameter is measured under the specified range of conditions and by the propagation delay between the digital control (IN) signal and analog output (COM or NO) signal when the switch is turning OFF.
$Q_C$	Charge injection is a measurement of unwanted signal coupling from the control (IN) input to the analog (NO or COM) output. This is measured in coulomb (C) and measured by the total charge induced due to switching of the control input. Charge injection, $Q_C = C_L \times \Delta V_{COM}$ , $C_L$ is the load capacitance and $\Delta V_{COM}$ is the change in analog output voltage.
$C_{NO(OFF)}$	Capacitance at the NO port when the corresponding channel (NO to COM) is OFF
$C_{NO(ON)}$	Capacitance at the NO port when the corresponding channel (NO to COM) is ON
$C_{COM(OFF)}$	Capacitance at the COM port when the corresponding channel (COM to NO) is OFF
$C_{COM(ON)}$	Capacitance at the COM port when the corresponding channel (COM to NO) is ON
$C_{IN}$	Capacitance of IN
$O_{ISO}$	OFF isolation of the switch is a measurement of OFF-state switch impedance. This is measured in dB in a specific frequency, with the corresponding channel (NO to COM) in the OFF state.
$X_{TALK}$	Crosstalk is a measurement of unwanted signal coupling from an ON channel to an adjacent ON channel (NC1 to NC2). This is measured in a specific frequency and in dB.
BW	Bandwidth of the switch. This is the frequency in which the gain of an ON channel is –3 dB below the DC gain.
THD	Total harmonic distortion is defined as the ratio of the root mean square (RMS) value of the second, third, and higher harmonics to the magnitude of fundamental harmonic.
$I_{CC}$	Static power-supply current with the control (IN) pin at $V_{CC}$ or GND

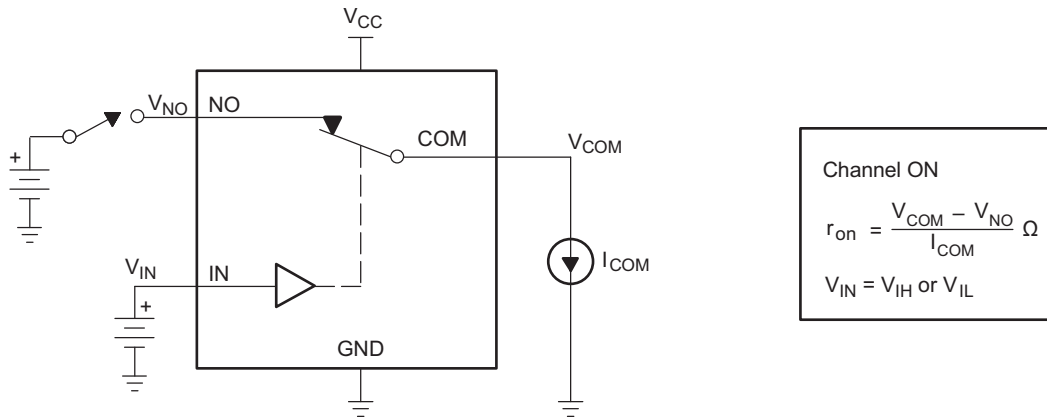

Figure 16. ON-State Resistance ( $r_{on}$ )

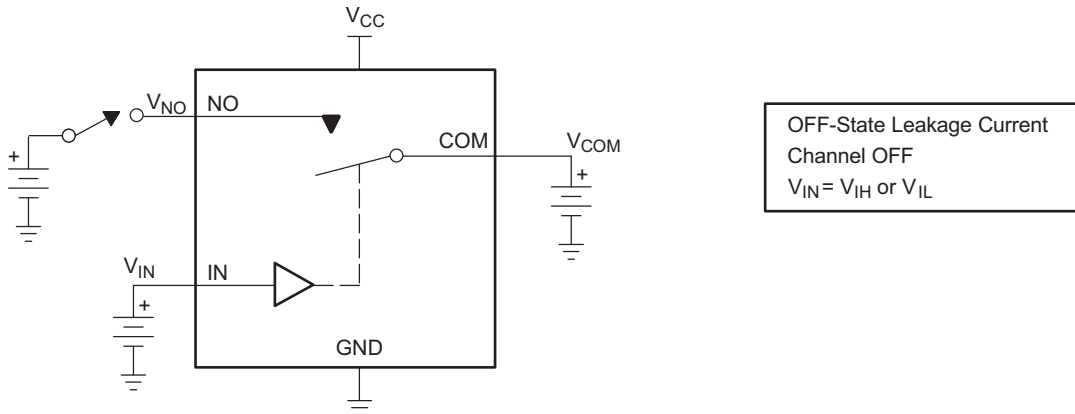

Figure 17. OFF-State Leakage Current ( $I_{COM(OFF)}$ ,  $I_{NO(OFF)}$ )

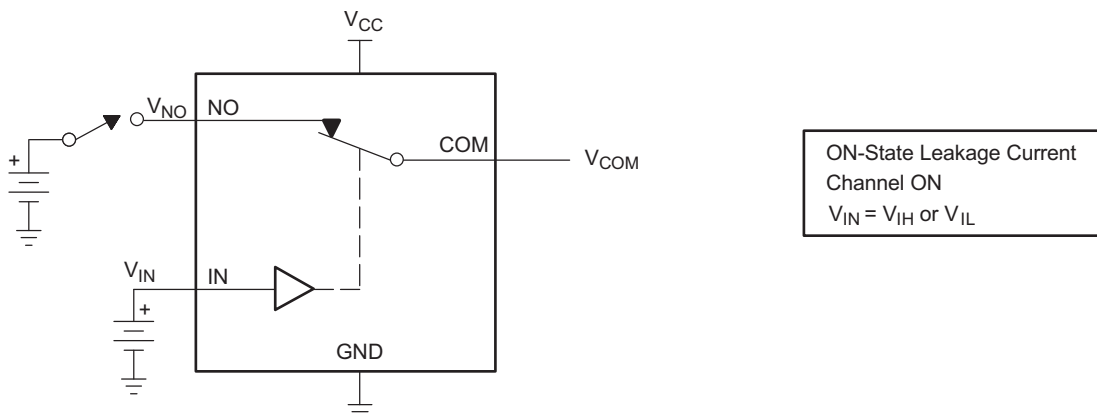

Figure 18. ON-State Leakage Current ( $I_{COM(ON)}$ ,  $I_{NO(ON)}$ )

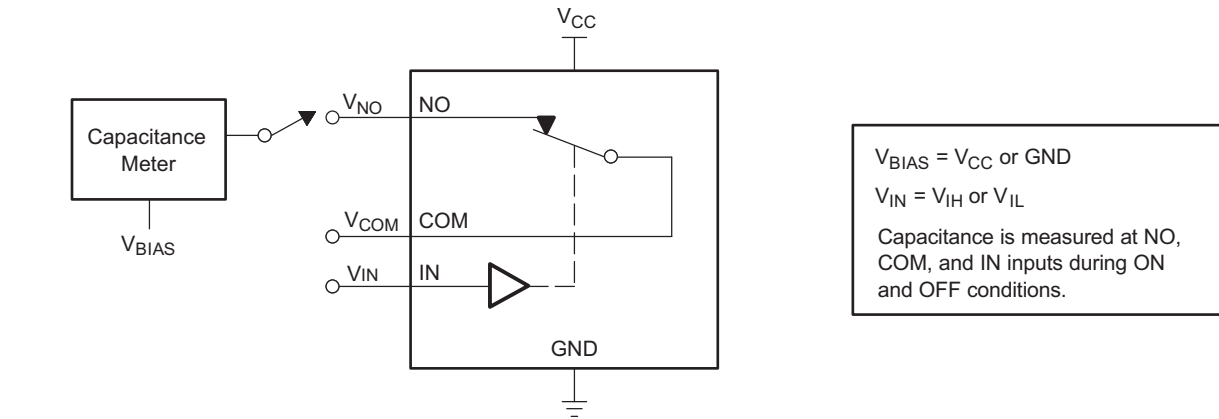
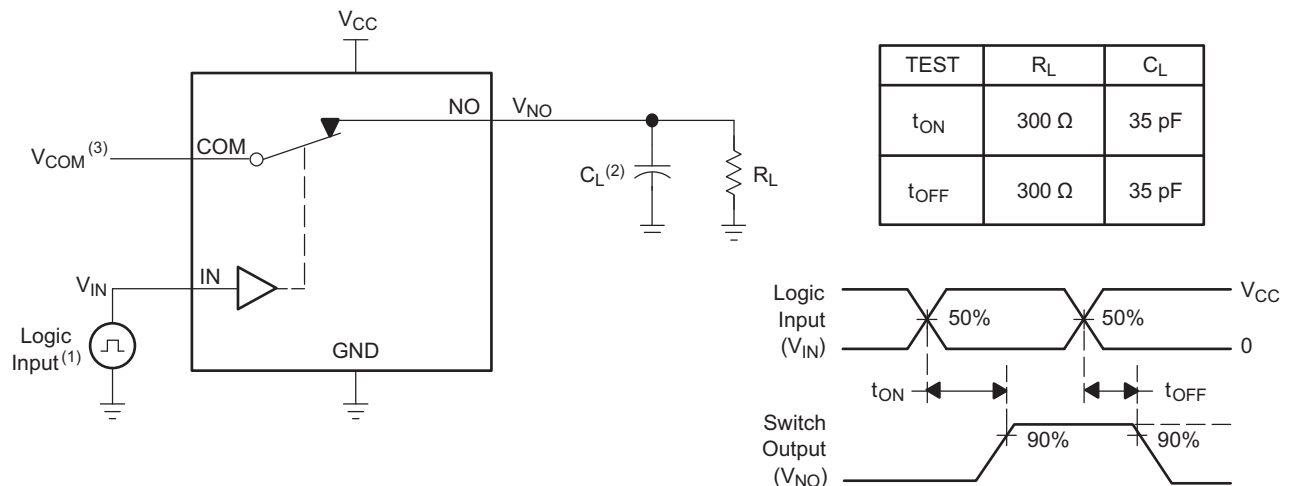

Figure 19. Capacitance ( $C_{IN}$ ,  $C_{COM(OFF)}$ ,  $C_{COM(ON)}$ ,  $C_{NO(OFF)}$ ,  $C_{NO(ON)}$ )



- (1) All input pulses are supplied by generators having the following characteristics: PRR ≤ 10 MHz, Z<sub>O</sub> = 50 Ω, t<sub>r</sub> < 5 ns, t<sub>f</sub> < 5 ns.
- (2) C<sub>L</sub> includes probe and jig capacitance.
- (3) See [Electrical Characteristics tables](#) for V<sub>COM</sub>.

Figure 20. Turn-On (t<sub>ON</sub>) and Turn-Off Time (t<sub>OFF</sub>)

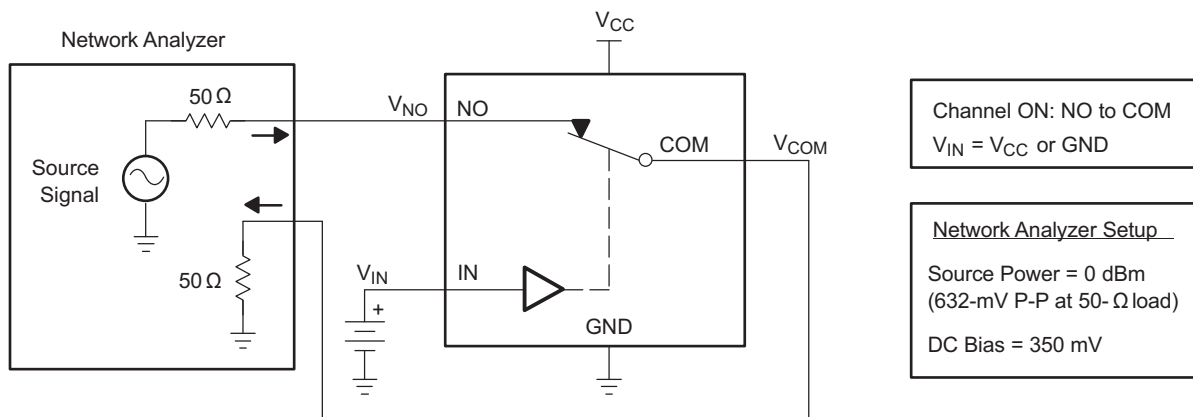

Figure 21. Bandwidth (BW)

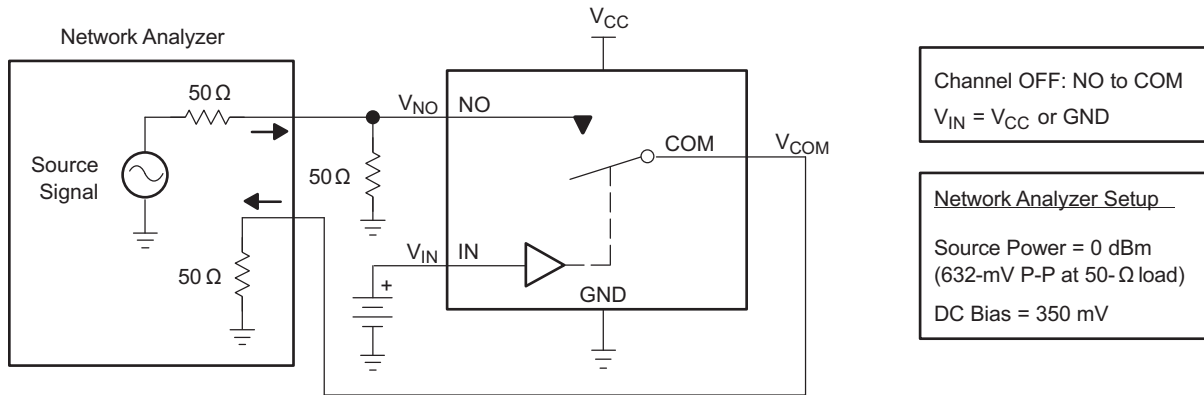

Figure 22. OFF Isolation ( $O_{ISO}$ )

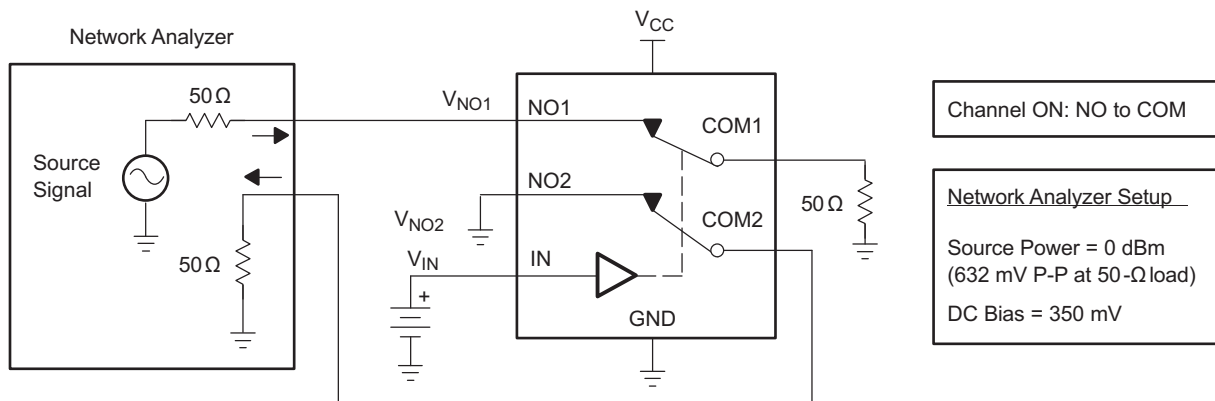
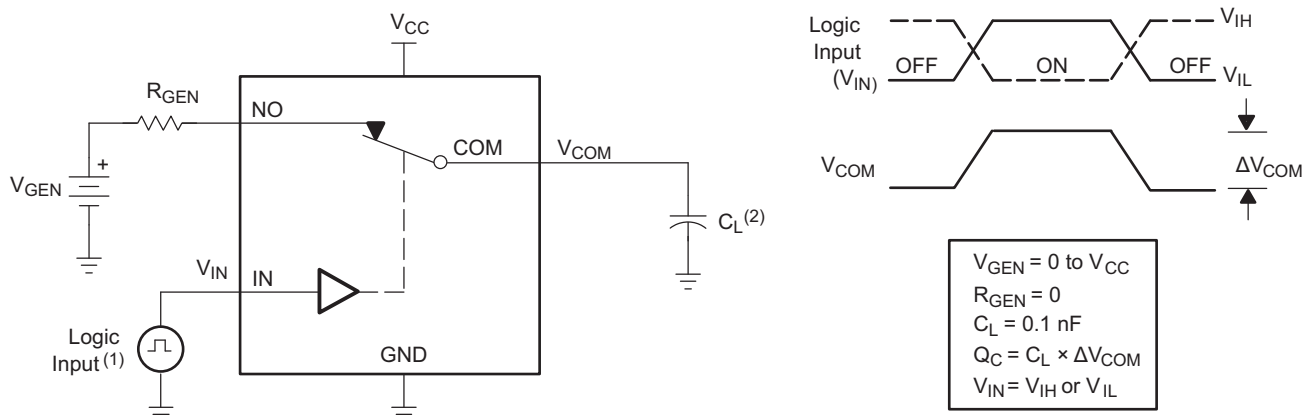
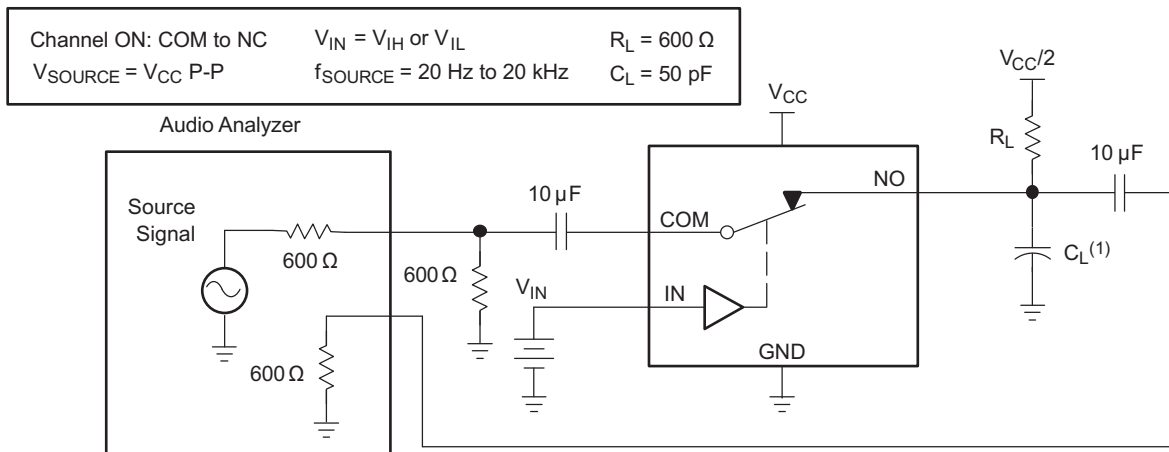

Figure 23. Crosstalk ( $X_{TALK}$ )



- (1) All input pulses are supplied by generators having the following characteristics: PRR  $\leq$  10 MHz,  $Z_O = 50 \Omega$ ,  $t_r < 5$  ns,  $t_f < 5$  ns.
- (2)  $C_L$  includes probe and jig capacitance.

Figure 24. Charge Injection ( $Q_C$ )



(1)  $C_L$  includes probe and jig capacitance.

**Figure 25. Total Harmonic Distortion (THD)**

## 8 Detailed Description

### 8.1 Overview

The TS5A2066 device is a 2-channel single-pole single-throw (1:1 SPST) analog switch that is designed to operate from 1.65 V to 5.5 V. This device can handle both digital and analog signals, and signals up to  $V_{CC}$  can be transmitted in either direction

### 8.2 Functional Block Diagram

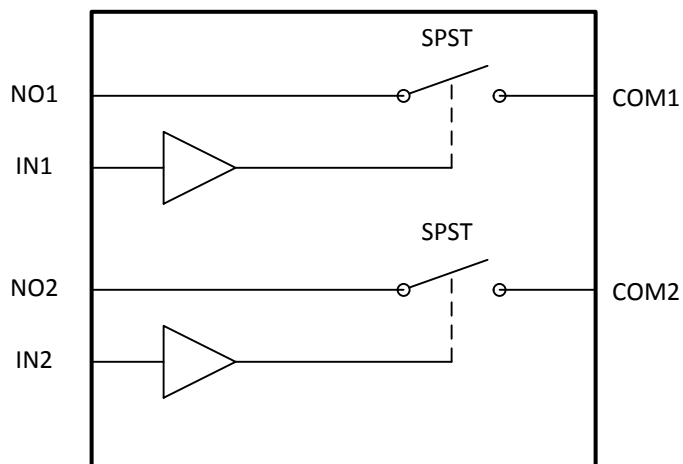

### 8.3 Feature Description

5-V tolerant control inputs allow 5-V logic levels to be present on the IN pin irrespective of the voltage on VCC pin.

Low ON-resistance and THD performance allows minimal signal distortion through device.

### 8.4 Device Functional Modes

Table 2 shows the functional modes for TS5A23166.

Table 2. Function Table

IN	NO TO COM, COM TO NO
L	OFF
H	ON

## 9 Application and Implementation

### NOTE

Information in the following applications sections is not part of the TI component specification, and TI does not warrant its accuracy or completeness. TI's customers are responsible for determining suitability of components for their purposes. Customers should validate and test their design implementation to confirm system functionality.

### 9.1 Application Information

The TS5A2066 2-channel, 1:1 SPST analog switch is a basic component that could be used in any electrical system design that signal isolation.

### 9.2 Typical Application

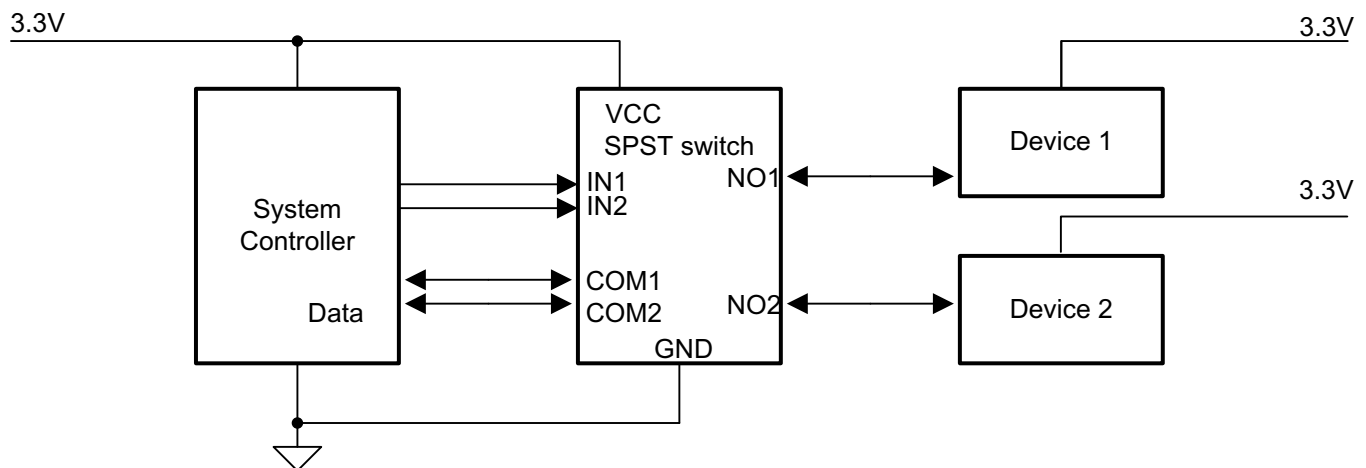

**Figure 26. Typical Application Circuit**

#### 9.2.1 Design Requirements

Ensure that all of the signals passing through the switch are within the specified ranges in the recommended operating conditions to ensure proper performance.

#### 9.2.2 Detailed Design Procedure

The TS5A2066 can be properly operated without any external components.

Unused signal path pins COM or NO maybe left floating or connected to ground through a 50-Ω resistor to prevent signal reflections back into the device.

TI recommends that the digital control pins (INX) be pulled up to VCC or down to GND to avoid undesired switch positions that could result from the floating pin. Leaving the logic pins floating may increase  $I_{CC}$ . Refer to the TI application report, [Implications of Slow or Floating CMOS Inputs \(SCBA004\)](#), for further details.

## Typical Application (continued)

### 9.2.3 Application Curves

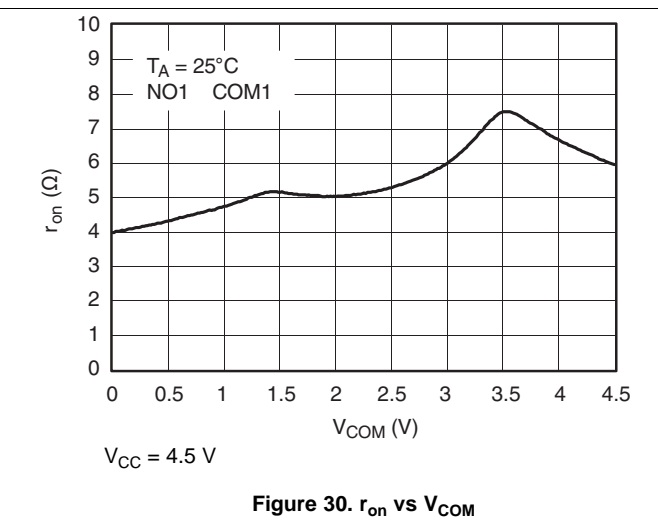
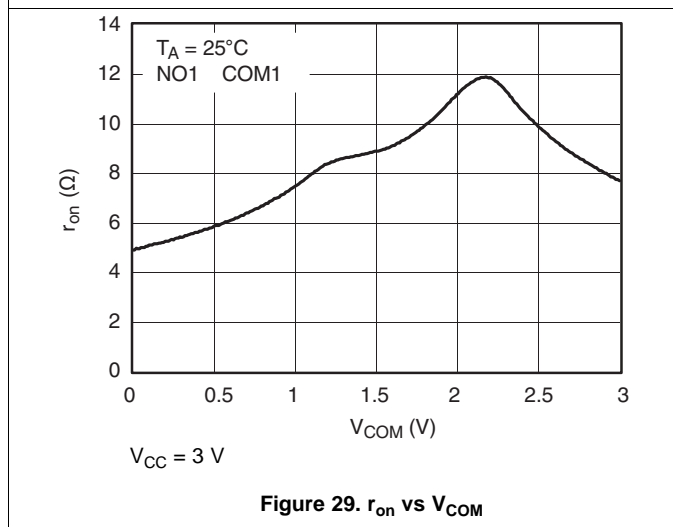
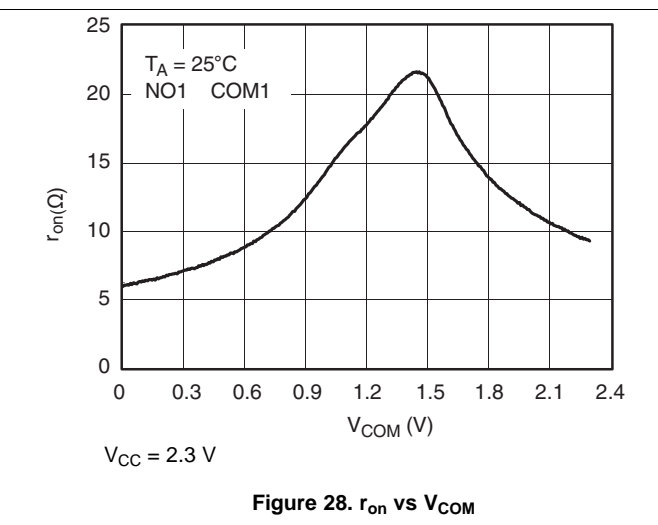
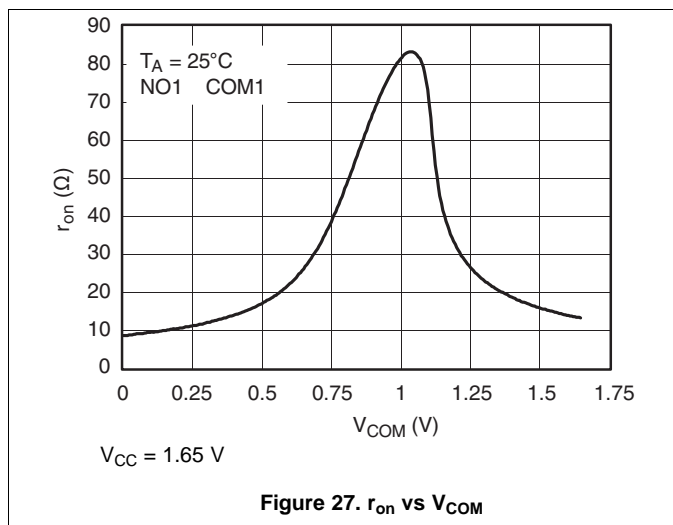

## 10 Power Supply Recommendations

Proper power-supply sequencing is recommended for all CMOS devices. Do not exceed the absolute maximum ratings, because stresses beyond the listed ratings can cause permanent damage to the device. Always sequence VCC on first, followed by NO, NC, or COM. Although it is not required, power-supply bypassing improves noise margin and prevents switching noise propagation from the VCC supply to other components. A 0.1- $\mu$ F capacitor, connected from VCC to GND, is adequate for most applications. Copyright

## 11 Layout

### 11.1 Layout Guidelines

High-speed switches require proper layout and design procedures for optimum performance. Reduce stray inductance and capacitance by keeping traces short and wide. Ensure that bypass capacitors are as close to the device as possible. Use large ground planes where possible. Use large ground planes where possible.

### 11.2 Layout Example

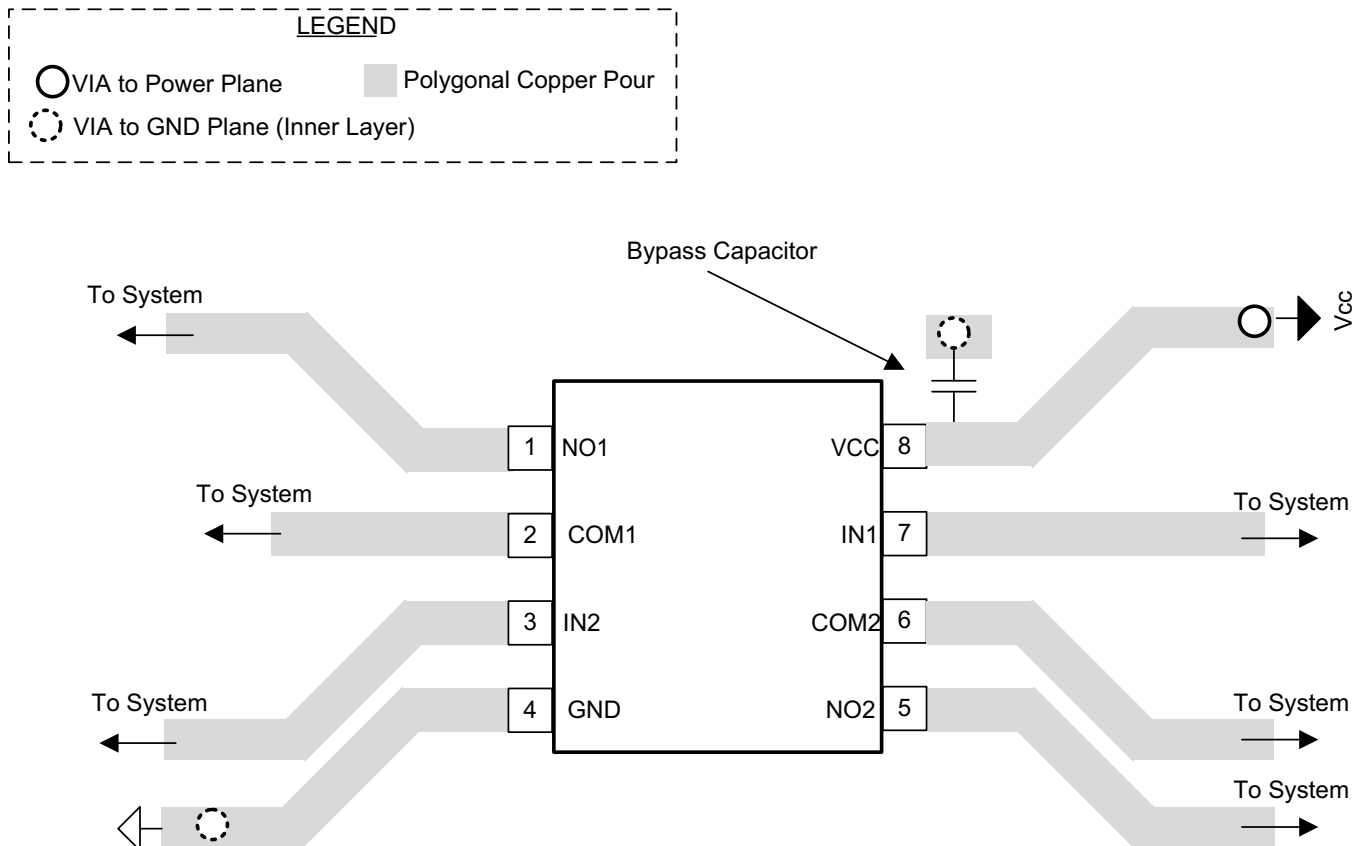

## 12 Device and Documentation Support

### 12.1 Receiving Notification of Documentation Updates

To receive notification of documentation updates, navigate to the device product folder on ti.com. In the upper right corner, click on *Alert me* to register and receive a weekly digest of any product information that has changed. For change details, review the revision history included in any revised document.

### 12.2 Community Resources

The following links connect to TI community resources. Linked contents are provided "AS IS" by the respective contributors. They do not constitute TI specifications and do not necessarily reflect TI's views; see TI's [Terms of Use](#).

**TI E2E™ Online Community** *TI's Engineer-to-Engineer (E2E) Community*. Created to foster collaboration among engineers. At e2e.ti.com, you can ask questions, share knowledge, explore ideas and help solve problems with fellow engineers.

**Design Support** *TI's Design Support* Quickly find helpful E2E forums along with design support tools and contact information for technical support.

### 12.3 Trademarks

E2E is a trademark of Texas Instruments.  
All other trademarks are the property of their respective owners.

### 12.4 Electrostatic Discharge Caution



This integrated circuit can be damaged by ESD. Texas Instruments recommends that all integrated circuits be handled with appropriate precautions. Failure to observe proper handling and installation procedures can cause damage.

ESD damage can range from subtle performance degradation to complete device failure. Precision integrated circuits may be more susceptible to damage because very small parametric changes could cause the device not to meet its published specifications.

### 12.5 Glossary

[SLYZ022](#) — *TI Glossary*.

This glossary lists and explains terms, acronyms, and definitions.

## 13 Mechanical, Packaging, and Orderable Information

The following pages include mechanical, packaging, and orderable information. This information is the most current data available for the designated devices. This data is subject to change without notice and revision of this document. For browser-based versions of this data sheet, refer to the left-hand navigation.

**PACKAGING INFORMATION**

Orderable Device	Status (1)	Package Type	Package Drawing	Pins	Package Qty	Eco Plan (2)	Lead/Ball Finish (6)	MSL Peak Temp (3)	Op Temp (°C)	Device Marking (4/5)	Samples
TS5A2066DCTR	ACTIVE	SM8	DCT	8	3000	Green (RoHS & no Sb/Br)	CU NIPDAU	Level-1-260C-UNLIM	-40 to 85	JAG Z	<a href="#">Samples</a>
TS5A2066DCTRE4	ACTIVE	SM8	DCT	8	3000	Green (RoHS & no Sb/Br)	CU NIPDAU	Level-1-260C-UNLIM	-40 to 85	JAG Z	<a href="#">Samples</a>
TS5A2066DCUR	ACTIVE	VSSOP	DCU	8	3000	Green (RoHS & no Sb/Br)	CU NIPDAU	Level-1-260C-UNLIM	-40 to 85	JAGR	<a href="#">Samples</a>
TS5A2066DCURE4	ACTIVE	VSSOP	DCU	8	3000	Green (RoHS & no Sb/Br)	CU NIPDAU	Level-1-260C-UNLIM	-40 to 85	JAGR	<a href="#">Samples</a>
TS5A2066DCURG4	ACTIVE	VSSOP	DCU	8	3000	Green (RoHS & no Sb/Br)	CU NIPDAU	Level-1-260C-UNLIM	-40 to 85	JAGR	<a href="#">Samples</a>
TS5A2066YZPR	ACTIVE	DSBGA	YZP	8	3000	Green (RoHS & no Sb/Br)	SNAGCU	Level-1-260C-UNLIM	-40 to 85	(J47, J4N)	<a href="#">Samples</a>

(1) The marketing status values are defined as follows:

**ACTIVE:** Product device recommended for new designs.

**LIFEBUY:** TI has announced that the device will be discontinued, and a lifetime-buy period is in effect.

**NRND:** Not recommended for new designs. Device is in production to support existing customers, but TI does not recommend using this part in a new design.

**PREVIEW:** Device has been announced but is not in production. Samples may or may not be available.

**OBSOLETE:** TI has discontinued the production of the device.

(2) **RoHS:** TI defines "RoHS" to mean semiconductor products that are compliant with the current EU RoHS requirements for all 10 RoHS substances, including the requirement that RoHS substance do not exceed 0.1% by weight in homogeneous materials. Where designed to be soldered at high temperatures, "RoHS" products are suitable for use in specified lead-free processes. TI may reference these types of products as "Pb-Free".

**RoHS Exempt:** TI defines "RoHS Exempt" to mean products that contain lead but are compliant with EU RoHS pursuant to a specific EU RoHS exemption.

**Green:** TI defines "Green" to mean the content of Chlorine (Cl) and Bromine (Br) based flame retardants meet JS709B low halogen requirements of <=1000ppm threshold. Antimony trioxide based flame retardants must also meet the <=1000ppm threshold requirement.

(3) MSL, Peak Temp. - The Moisture Sensitivity Level rating according to the JEDEC industry standard classifications, and peak solder temperature.

(4) There may be additional marking, which relates to the logo, the lot trace code information, or the environmental category on the device.

(5) Multiple Device Markings will be inside parentheses. Only one Device Marking contained in parentheses and separated by a "~" will appear on a device. If a line is indented then it is a continuation of the previous line and the two combined represent the entire Device Marking for that device.

<sup>(6)</sup> Lead/Ball Finish - Orderable Devices may have multiple material finish options. Finish options are separated by a vertical ruled line. Lead/Ball Finish values may wrap to two lines if the finish value exceeds the maximum column width.

**Important Information and Disclaimer:**The information provided on this page represents TI's knowledge and belief as of the date that it is provided. TI bases its knowledge and belief on information provided by third parties, and makes no representation or warranty as to the accuracy of such information. Efforts are underway to better integrate information from third parties. TI has taken and continues to take reasonable steps to provide representative and accurate information but may not have conducted destructive testing or chemical analysis on incoming materials and chemicals. TI and TI suppliers consider certain information to be proprietary, and thus CAS numbers and other limited information may not be available for release.

In no event shall TI's liability arising out of such information exceed the total purchase price of the TI part(s) at issue in this document sold by TI to Customer on an annual basis.

## TAPE AND REEL INFORMATION



### QUADRANT ASSIGNMENTS FOR PIN 1 ORIENTATION IN TAPE



\*All dimensions are nominal

Device	Package Type	Package Drawing	Pins	SPQ	Reel Diameter (mm)	Reel Width W1 (mm)	A0 (mm)	B0 (mm)	K0 (mm)	P1 (mm)	W (mm)	Pin1 Quadrant
TS5A2066DCTR	SM8	DCT	8	3000	180.0	13.0	3.35	4.5	1.55	4.0	12.0	Q3
TS5A2066DCUR	VSSOP	DCU	8	3000	180.0	8.4	2.25	3.35	1.05	4.0	8.0	Q3
TS5A2066DCURG4	VSSOP	DCU	8	3000	180.0	8.4	2.25	3.35	1.05	4.0	8.0	Q3

**TAPE AND REEL BOX DIMENSIONS**

\*All dimensions are nominal

Device	Package Type	Package Drawing	Pins	SPQ	Length (mm)	Width (mm)	Height (mm)
TS5A2066DCTR	SM8	DCT	8	3000	182.0	182.0	20.0
TS5A2066DCUR	VSSOP	DCU	8	3000	202.0	201.0	28.0
TS5A2066DCURG4	VSSOP	DCU	8	3000	202.0	201.0	28.0

DCU (R-PDSO-G8)

PLASTIC SMALL-OUTLINE PACKAGE (DIE DOWN)

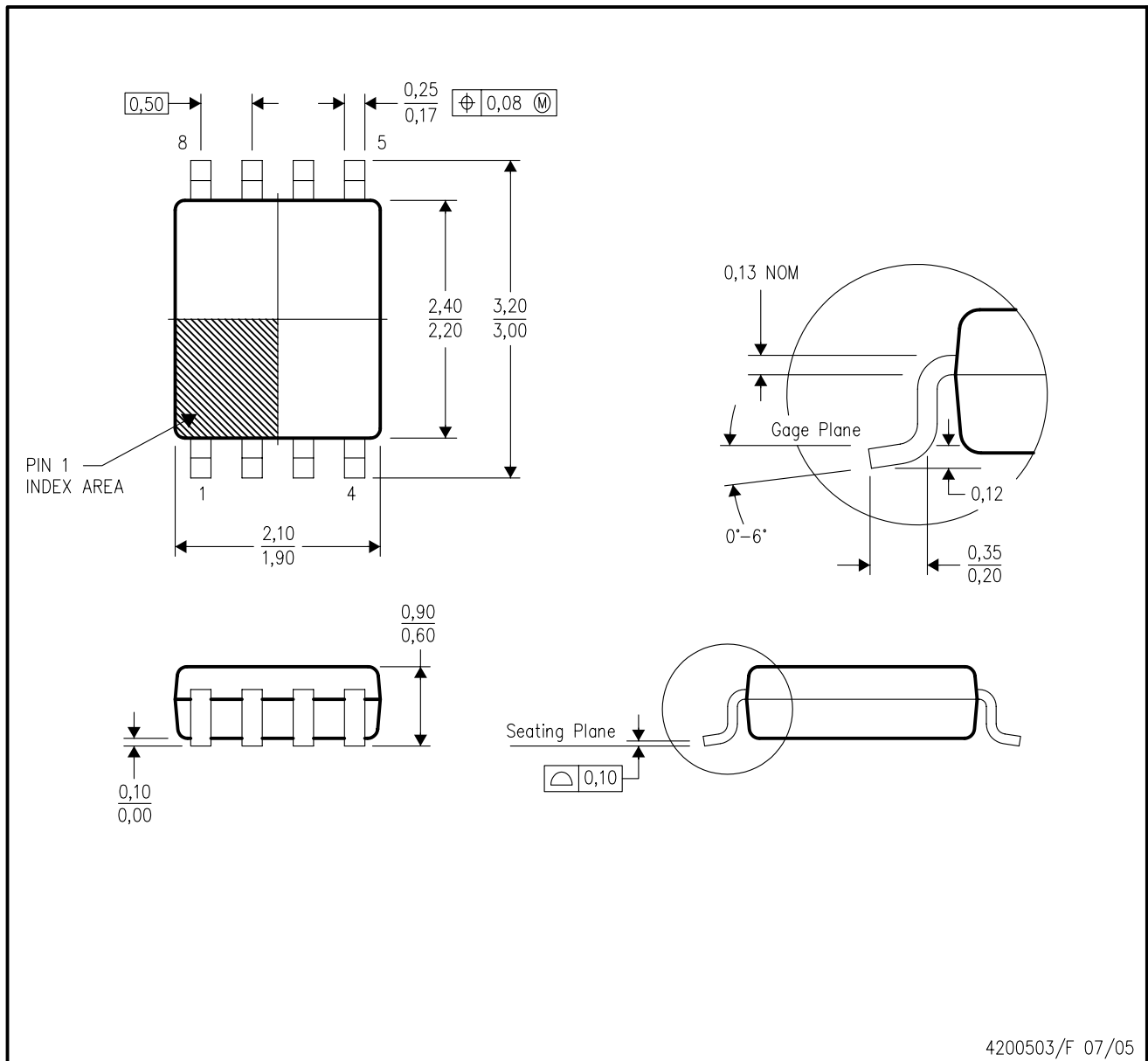

- NOTES:
- A. All linear dimensions are in millimeters.
  - B. This drawing is subject to change without notice.
  - C. Body dimensions do not include mold flash or protrusion. Mold flash and protrusion shall not exceed 0.15 per side.
  - D. Falls within JEDEC MO-187 variation CA.

DCU (S-PDSO-G8)

PLASTIC SMALL OUTLINE PACKAGE (DIE DOWN)

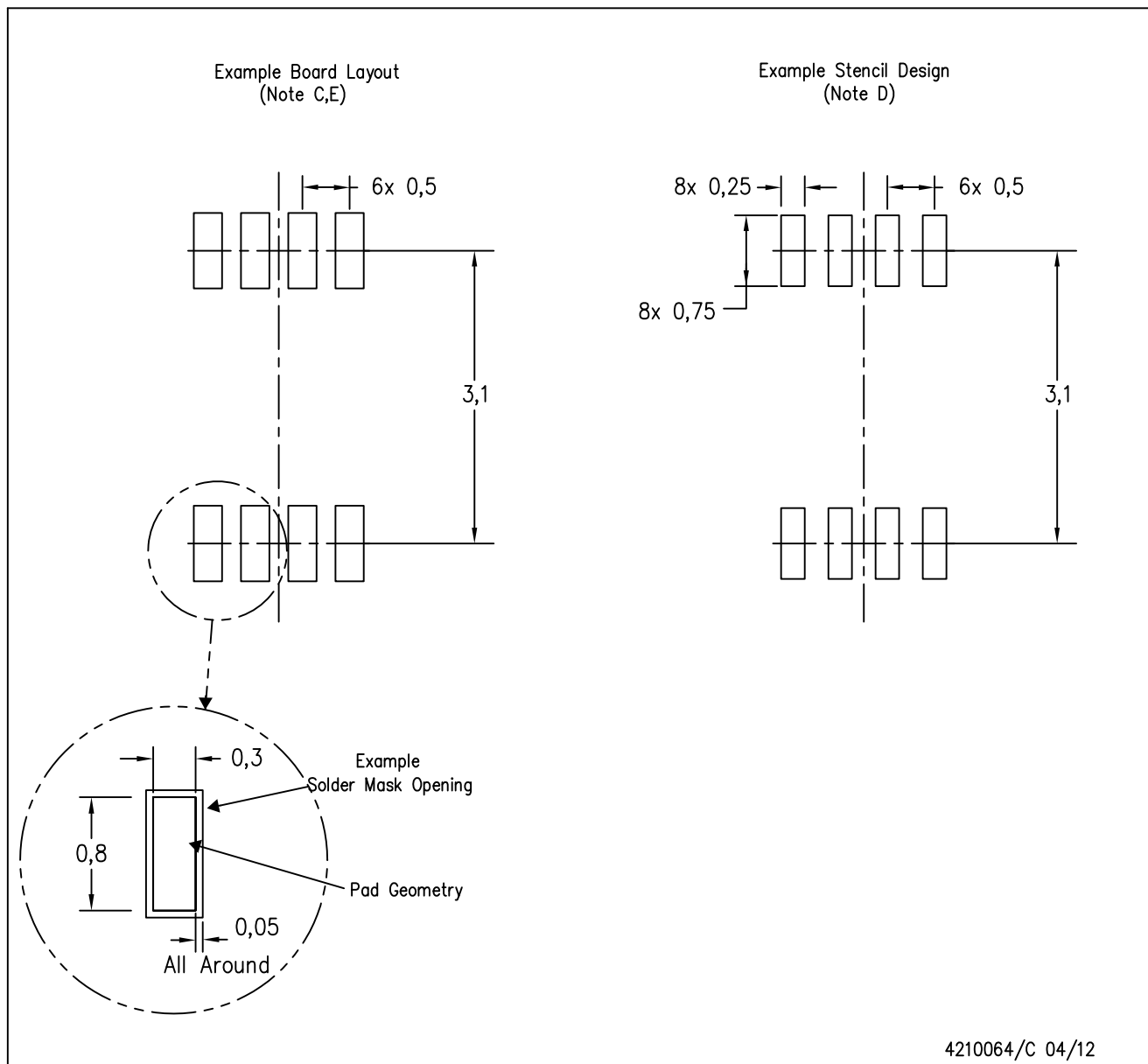

- NOTES:
- A. All linear dimensions are in millimeters.
  - B. This drawing is subject to change without notice.
  - C. Publication IPC-7351 is recommended for alternate designs.
  - D. Laser cutting apertures with trapezoidal walls and also rounding corners will offer better paste release. Customers should contact their board assembly site for stencil design recommendations. Refer to IPC-7525 for other stencil recommendations.
  - E. Customers should contact their board fabrication site for solder mask tolerances between and around signal pads.

DCT (R-PDSO-G8)

PLASTIC SMALL-OUTLINE PACKAGE

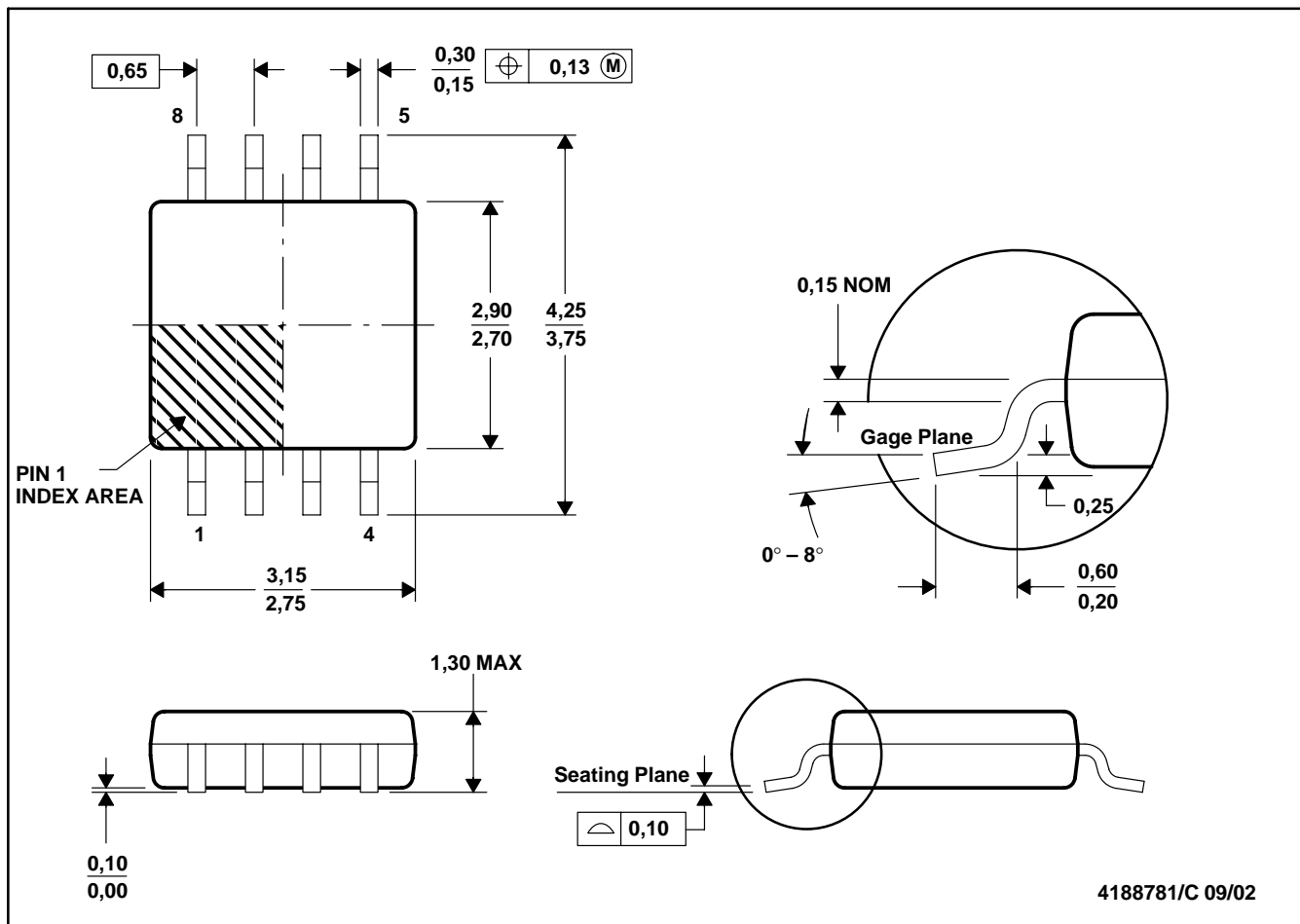

- NOTES:
- A. All linear dimensions are in millimeters.
  - B. This drawing is subject to change without notice.
  - C. Body dimensions do not include mold flash or protrusion
  - D. Falls within JEDEC MO-187 variation DA.

DCT (R-PDSO-G8)

PLASTIC SMALL OUTLINE

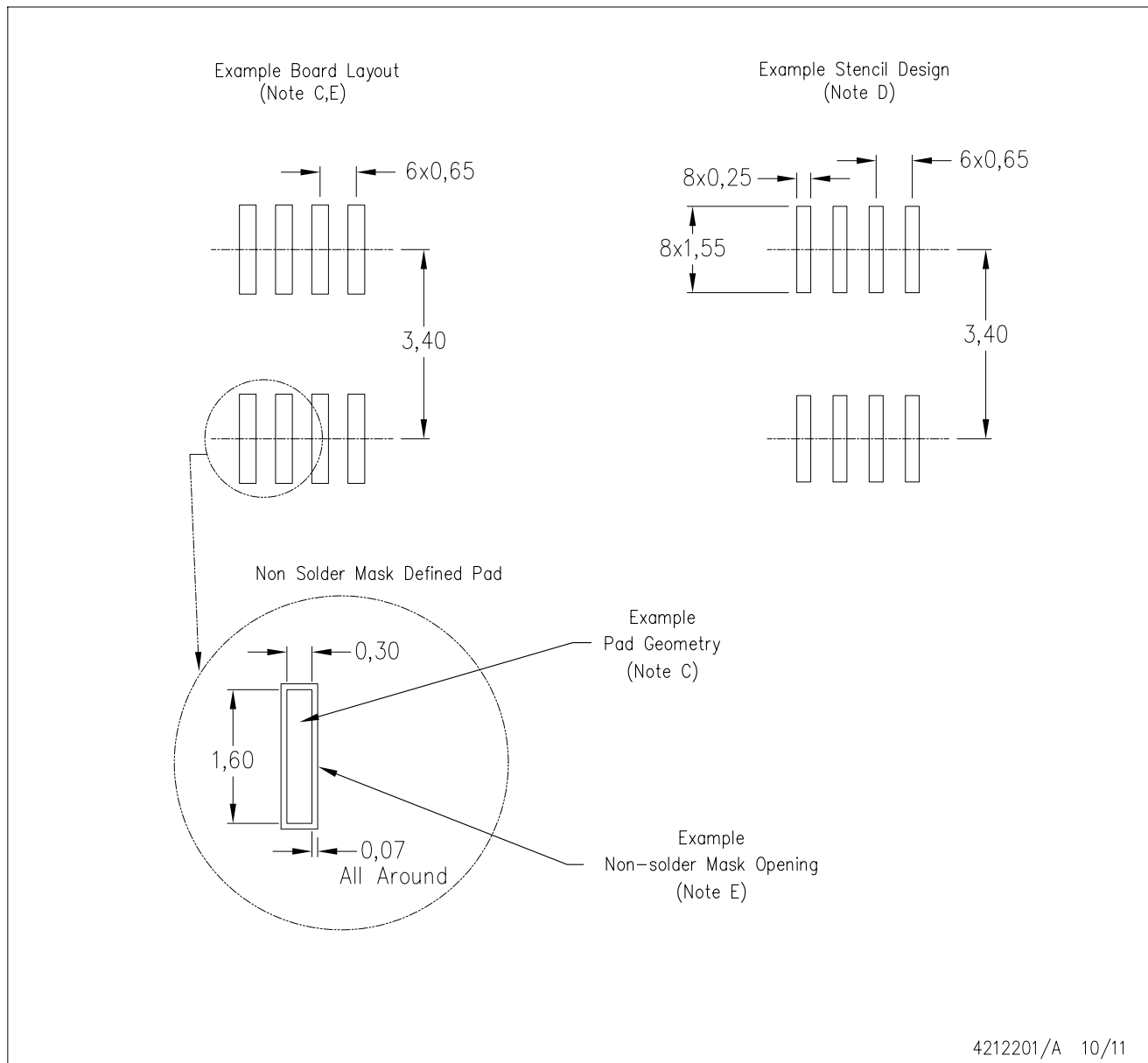

- NOTES:
- A. All linear dimensions are in millimeters.
  - B. This drawing is subject to change without notice.
  - C. Publication IPC-7351 is recommended for alternate designs.
  - D. Laser cutting apertures with trapezoidal walls and also rounding corners will offer better paste release. Customers should contact their board assembly site for stencil design recommendations. Refer to IPC-7525.
  - E. Customers should contact their board fabrication site for solder mask tolerances between and around signal pads.

YZP0008

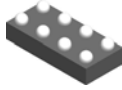

PACKAGE OUTLINE

DSBGA - 0.5 mm max height

DIE SIZE BALL GRID ARRAY

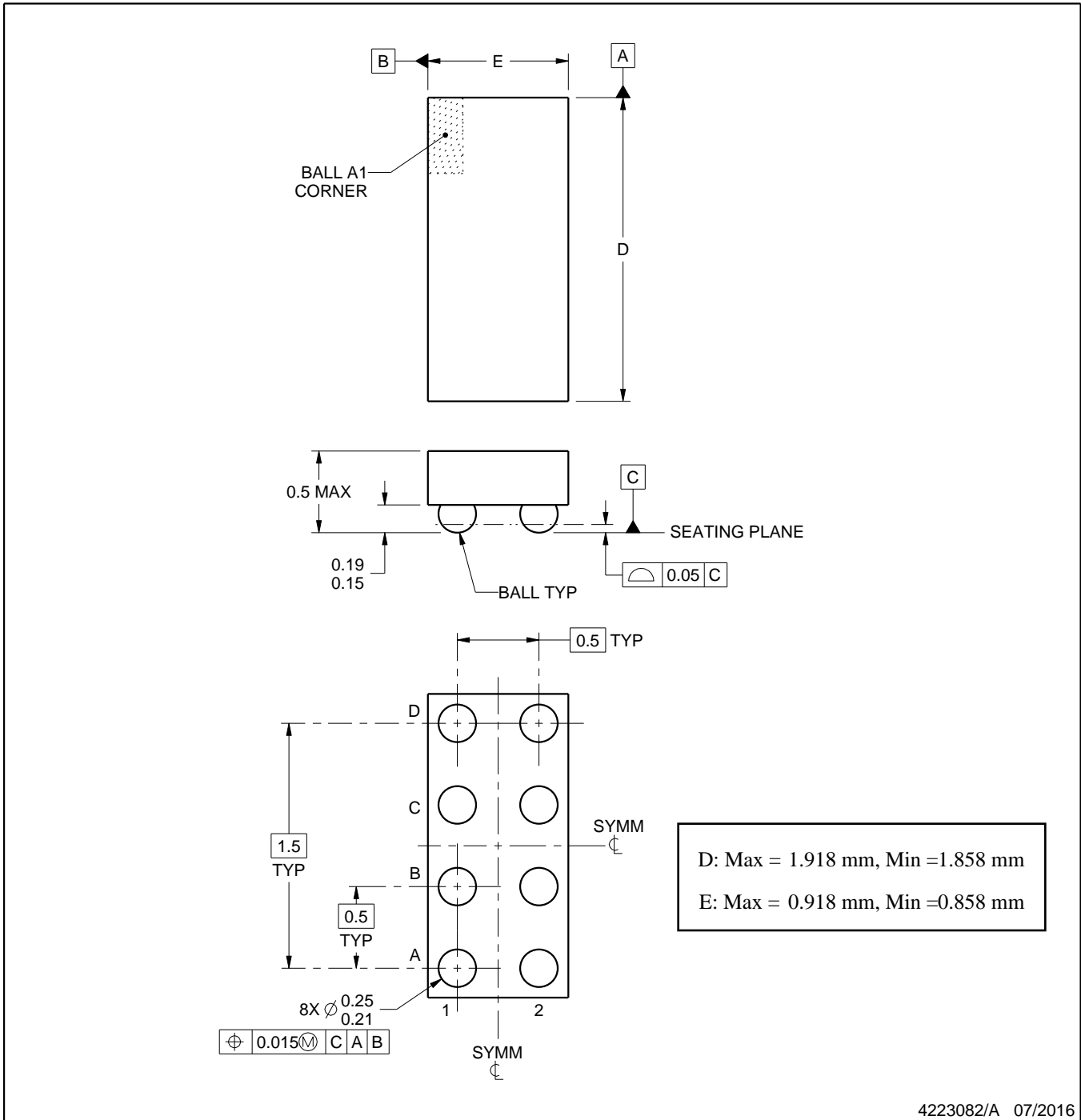

NOTES:

1. All linear dimensions are in millimeters. Any dimensions in parenthesis are for reference only. Dimensioning and tolerancing per ASME Y14.5M.
2. This drawing is subject to change without notice.

# EXAMPLE BOARD LAYOUT

YZP0008

DSBGA - 0.5 mm max height

DIE SIZE BALL GRID ARRAY

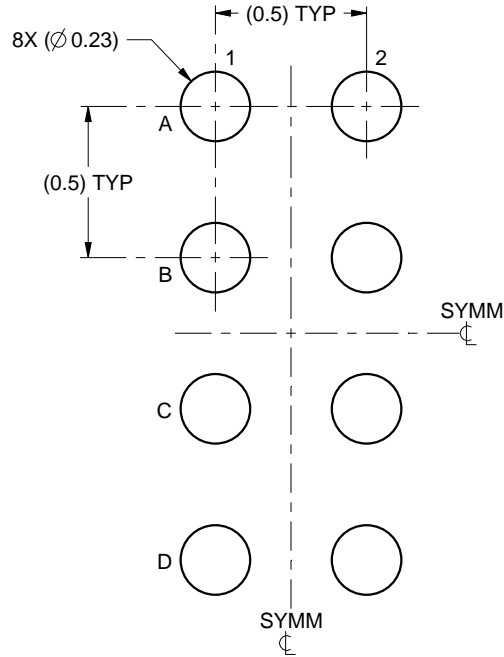

LAND PATTERN EXAMPLE  
SCALE:40X

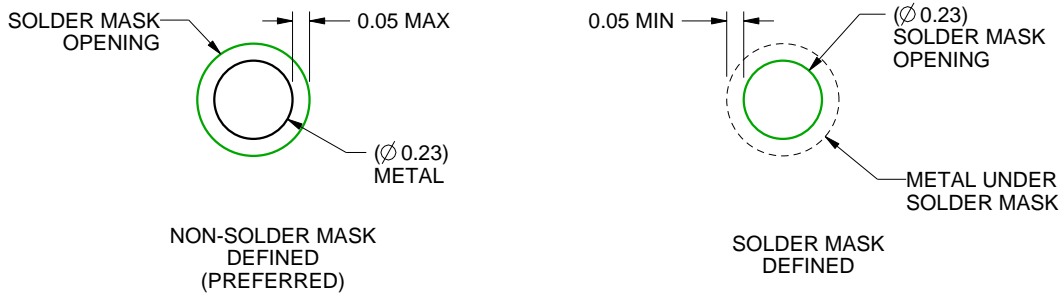

SOLDER MASK DETAILS  
NOT TO SCALE

4223082/A 07/2016

NOTES: (continued)

- Final dimensions may vary due to manufacturing tolerance considerations and also routing constraints. For more information, see Texas Instruments literature number SNVA009 ([www.ti.com/lit/snva009](http://www.ti.com/lit/snva009)).

# EXAMPLE STENCIL DESIGN

YZP0008

DSBGA - 0.5 mm max height

DIE SIZE BALL GRID ARRAY

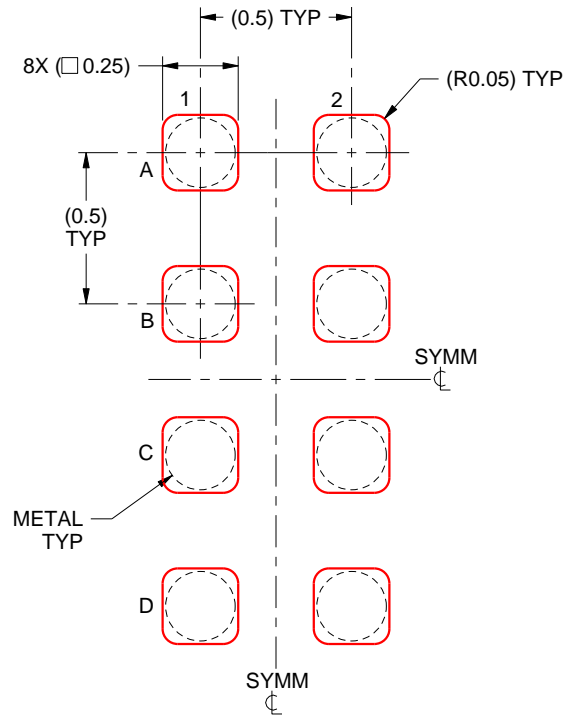

SOLDER PASTE EXAMPLE  
BASED ON 0.1 mm THICK STENCIL  
SCALE:40X

4223082/A 07/2016

NOTES: (continued)

4. Laser cutting apertures with trapezoidal walls and rounded corners may offer better paste release.

## IMPORTANT NOTICE AND DISCLAIMER

TI PROVIDES TECHNICAL AND RELIABILITY DATA (INCLUDING DATASHEETS), DESIGN RESOURCES (INCLUDING REFERENCE DESIGNS), APPLICATION OR OTHER DESIGN ADVICE, WEB TOOLS, SAFETY INFORMATION, AND OTHER RESOURCES "AS IS" AND WITH ALL FAULTS, AND DISCLAIMS ALL WARRANTIES, EXPRESS AND IMPLIED, INCLUDING WITHOUT LIMITATION ANY IMPLIED WARRANTIES OF MERCHANTABILITY, FITNESS FOR A PARTICULAR PURPOSE OR NON-INFRINGEMENT OF THIRD PARTY INTELLECTUAL PROPERTY RIGHTS.

These resources are intended for skilled developers designing with TI products. You are solely responsible for (1) selecting the appropriate TI products for your application, (2) designing, validating and testing your application, and (3) ensuring your application meets applicable standards, and any other safety, security, or other requirements. These resources are subject to change without notice. TI grants you permission to use these resources only for development of an application that uses the TI products described in the resource. Other reproduction and display of these resources is prohibited. No license is granted to any other TI intellectual property right or to any third party intellectual property right. TI disclaims responsibility for, and you will fully indemnify TI and its representatives against, any claims, damages, costs, losses, and liabilities arising out of your use of these resources.

TI's products are provided subject to TI's Terms of Sale ([www.ti.com/legal/termsofsale.html](http://www.ti.com/legal/termsofsale.html)) or other applicable terms available either on [ti.com](http://ti.com) or provided in conjunction with such TI products. TI's provision of these resources does not expand or otherwise alter TI's applicable warranties or warranty disclaimers for TI products.

Mailing Address: Texas Instruments, Post Office Box 655303, Dallas, Texas 75265  
Copyright © 2018, Texas Instruments Incorporated

## Looking for pricing, stock, or lifecycle information?

Click below to explore more details on WIN SOURCE:

 [View TS5A2066DCTR on WIN SOURCE](#)

 [Texas Instruments](#) Information

## Optimize Your Supply Chain with WIN SOURCE Solutions

-  Global Sourcing Solution
-  Obsolete Management
-  Cost Control Management
-  Shortage Management
-  Alternative Solution
-  Excess Inventory Management