



**THE DATASHEET OF  
UCD90124ARGCR**



# 12-Rail Power Supply Sequencer and Monitor with ACPI Support and Fan Control

Check for Samples: [UCD90124A](#)

## FEATURES

- **Monitor and Sequence 12 Voltage Rails**
  - All Rails Sampled Every 400  $\mu$ s
  - 12-bit ADC With 2.5-V, 0.5% Internal  $V_{REF}$
  - Sequence Based on Time, Rail and Pin Dependencies
  - Four Programmable Undervoltage and Overvoltage Thresholds per Monitor
- **Nonvolatile Error and Peak-Value Logging per Monitor (up to 12 Fault Detail Entries)**
- **Closed-Loop Margining for 10 Rails**
  - Margin Output Adjusts Rail Voltage to Match User-Defined Margin Thresholds
- **Programmable Watchdog Timer and System Reset**
- **Flexible Digital I/O Configuration**
- **Pin-Selected Rail States**
- **Multiphase PWM Clock Generator**
  - Clock Frequencies From 15.259 kHz to 125 MHz
  - Capability to Configure Independent Clock Outputs for Synchronizing Switch-Mode Power Supplies
- **JTAG and I<sup>2</sup>C/SMBus/ PMBus™ Interfaces**

## APPLICATIONS

- **Industrial / ATE**
- **Telecommunications and Networking Equipment**
- **Servers and Storage Systems**
- **Any System Requiring Sequencing and Monitoring of Multiple Power Rails**

## DESCRIPTION

The UCD90124A is a 12-rail PMBus/I<sup>2</sup>C addressable power-supply sequencer and monitor. The device integrates a 12-bit ADC for monitoring up to 12 power-supply voltage inputs. Twenty-six GPIO pins can be used for power supply enables, power-on reset signals, external interrupts, cascading, or other system functions. Twelve of these pins offer PWM functionality. Using these pins, the UCD90124A offers support for fan control, margining, and general-purpose PWM functions.

Specific power states can be achieved using the Pin-Selected Rail States feature. This feature allows with the use of up to 3 GPIOs to enable and disable any rail. This is useful for implementing system low-power modes and the Advanced Configuration and Power Interface (ACPI) specification that is used for hardware devices.

The TI Fusion Digital Power™ designer software is provided for device configuration. This PC-based graphical user interface (GUI) offers an intuitive interface for configuring, storing, and monitoring all system operating parameters.

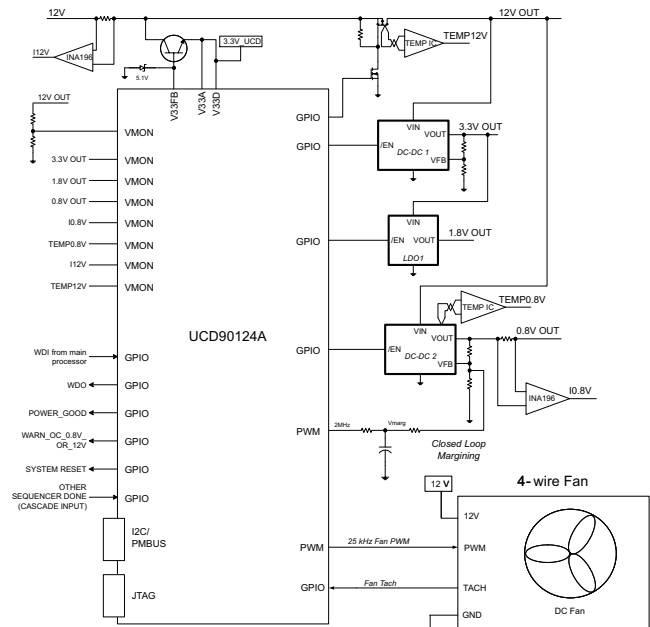

Please be aware that an important notice concerning availability, standard warranty, and use in critical applications of Texas Instruments semiconductor products and disclaimers thereto appears at the end of this data sheet.

PMBus, Fusion Digital Power are trademarks of Texas Instruments.

# UCD90124A

SLVSN8 – JANUARY 2012

www.ti.com



This integrated circuit can be damaged by ESD. Texas Instruments recommends that all integrated circuits be handled with appropriate precautions. Failure to observe proper handling and installation procedures can cause damage.

ESD damage can range from subtle performance degradation to complete device failure. Precision integrated circuits may be more susceptible to damage because very small parametric changes could cause the device not to meet its published specifications.

## FUNCTIONAL BLOCK DIAGRAM

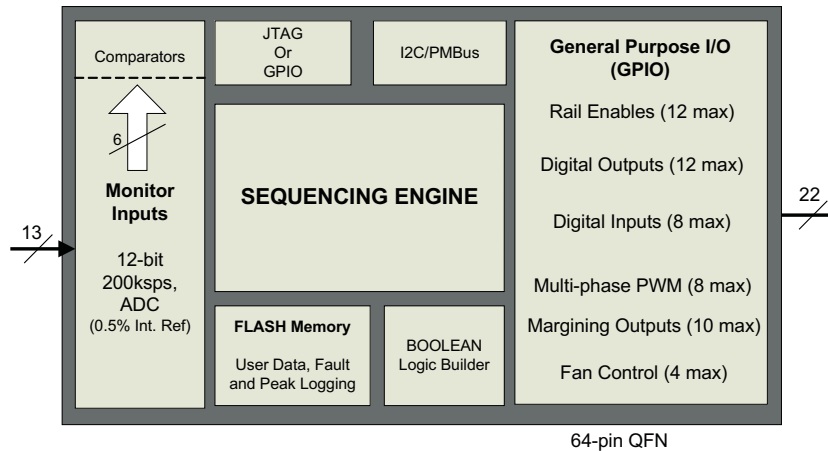

## ORDERING INFORMATION

For the most current package and ordering information, see the Package Option Addendum at the end of this document, or see the TI Web site at [www.ti.com](http://www.ti.com).

## ABSOLUTE MAXIMUM RATINGS<sup>(1)</sup>

	VALUE	UNIT
Voltage applied at V33D to DV <sub>SS</sub>	-0.3 to 3.8	V
Voltage applied at V33A to AV <sub>SS</sub>	-0.3 to 3.8	V
Voltage applied to any other pin <sup>(2)</sup>	-0.3 to (V33A + 0.3)	V
Storage temperature (T <sub>stg</sub> )	-40 to 150	°C
ESD rating	Human-body model (HBM)	2.5
	Charged-device model (CDM)	750

(1) Stresses beyond those listed under *Absolute Maximum Ratings* may cause permanent damage to the device. These are stress ratings only and functional operation of the device at these or any other conditions beyond those indicated under *Recommended Operating Conditions* is not implied. Exposure to absolute-maximum-rated conditions for extended periods may affect device reliability.

(2) All voltages referenced to V<sub>SS</sub>

## THERMAL INFORMATION

THERMAL METRIC <sup>(1)</sup>		UCD90124A	UNITS
		RGC (64) PINS	
$\theta_{JA}$	Junction-to-ambient thermal resistance	26.4	°C/W
$\theta_{JC(top)}$	Junction-to-case(top) thermal resistance	21.2	
$\theta_{JB}$	Junction-to-board thermal resistance	1.7	
$\psi_{JT}$	Junction-to-top characterization parameter	0.7	
$\psi_{JB}$	Junction-to-board characterization parameter	8.8	
$\theta_{JC(bottom)}$	Junction-to-case(bottom) thermal resistance	1.7	

(1) For more information about traditional and new thermal metrics, see the *IC Package Thermal Metrics* application report, [SPRA953](http://SPRA953).

## RECOMMENDED OPERATING CONDITIONS

	MIN	NOM	MAX	UNIT
Supply voltage during operation ( $V_{33D}$ , $V_{33DIO}$ , $V_{33A}$ )	3	3.3	3.6	V
Operating free-air temperature range, $T_A$	-40		110	°C
Junction temperature, $T_J$			125	°C

## ELECTRICAL CHARACTERISTICS

over operating free-air temperature range (unless otherwise noted)

PARAMETER		TEST CONDITIONS	MIN	NOM	MAX	UNIT
<b>SUPPLY CURRENT</b>						
$I_{V33A}$	Supply current <sup>(1)</sup>	$V_{V33A} = 3.3\text{ V}$		8		mA
$I_{V33DIO}$		$V_{V33DIO} = 3.3\text{ V}$		2		mA
$I_{V33D}$		$V_{V33D} = 3.3\text{ V}$		40		mA
$I_{V33D}$		$V_{V33D} = 3.3\text{ V}$ , storing configuration parameters in flash memory			50	
<b>EXTERNALLY SUPPLIED 3.3V POWER</b>						
$V_{V33D}$ , $V_{V33DIO}$	Digital 3.3-V power	$T_A = 25^\circ\text{C}$	3		3.6	V
$V_{V33A}$	Analog 3.3-V power	$T_A = 25^\circ\text{C}$	3		3.6	V
<b>ANALOG INPUTS (MON1–MON13)</b>						
$V_{MON}$	Input voltage range	MON1–MON9	0		2.5	V
		MON10–MON13	0.2		2.5	V
INL	ADC integral nonlinearity		-2.5		2.5	mV
$I_{ikg}$	Input leakage current	3 V applied to pin			100	nA
$I_{OFFSET}$	Input offset current	1-k $\Omega$ source impedance	-5		5	$\mu\text{A}$
$R_{IN}$	Input impedance	MON1–MON9, ground reference	8			M $\Omega$
		MON10–MON13, ground reference	0.5	1.5	3	M $\Omega$
$C_{IN}$	Input capacitance				10	pF
$t_{CONVERT}$	ADC sample period	16 voltages sampled, 3.89 $\mu\text{sec/sample}$		400		$\mu\text{sec}$
$V_{REF}$	ADC 2.5 V, internal reference accuracy	0°C to 125°C	-0.5		0.5	%
		-40°C to 125°C	-1		1	%
<b>ANALOG INPUT (PMBUS_ADDRx)</b>						
$I_{BIAS}$	Bias current for PMBus Addr pins		9		11	$\mu\text{A}$
$V_{ADDR\_OPEN}$	Voltage – open pin	PMBUS_ADDR0, PMBUS_ADDR1 open	2.26			V
$V_{ADDR\_SHORT}$	Voltage – shorted pin	PMBUS_ADDR0, PMBUS_ADDR1 short to ground			0.124	V
$T_{internal}$	Internal temperature sense accuracy	Over range from 0°C to 100°C	-5		5	°C
<b>DIGITAL INPUTS AND OUTPUTS</b>						
$V_{OL}$	Low-level output voltage	$I_{OL} = 6\text{ mA}^{(2)}$ , $V_{33DIO} = 3\text{ V}$			Dgnd + 0.25	V
$V_{OH}$	High-level output voltage	$I_{OH} = -6\text{ mA}^{(3)}$ , $V_{33DIO} = 3\text{ V}$		$V_{33DIO} - 0.6$		V
$V_{IH}$	High-level input voltage	$V_{33DIO} = 3\text{ V}$	2.1		3.6	V
$V_{IL}$	Low-level input voltage	$V_{33DIO} = 3.5\text{ V}$			1.4	V
<b>FAN CONTROL INPUTS AND OUTPUTS</b>						
$T_{PWM\_FREQ}$	FAN-PWM frequency	FPWM1-8	15.259		125000	kHz
		PWM1		10		
		PWM2		1		
		PWM3-4	0.001		7800	
$DUTY_{PWM}$	FAN-PWM duty cycle range		0		100	%
$Tach_{RANGE}$	FAN-TACH resolution	For 1 Tach pulse per revolution		30		RPM
$t_{MIN}$	FAN-TACH minimum pulse width	Either positive or negative polarity	200			$\mu\text{s}$

(1) Typical supply current values are based on device programmed but not configured, and no peripherals connected to any pins.

(2) The maximum total current,  $I_{OL,max}$ , for all outputs combined, should not exceed 12 mA to hold the maximum voltage drop specified.

(3) The maximum total current,  $I_{OH,max}$ , for all outputs combined, should not exceed 48 mA to hold the maximum voltage drop specified.

# UCD90124A

SLVSAN8 – JANUARY 2012

[www.ti.com](http://www.ti.com)

## ELECTRICAL CHARACTERISTICS (continued)

over operating free-air temperature range (unless otherwise noted)

PARAMETER		TEST CONDITIONS	MIN	NOM	MAX	UNIT
<b>MARGINING OUTPUTS</b>						
T <sub>PWM_FREQ</sub>	MARGINING-PWM frequency	FPWM1-8	15.260		125000	kHz
		PWM3-4	0.001		7800	
DUTY <sub>PWM</sub>	MARGINING-PWM duty cycle range		0		100	%
<b>SYSTEM PERFORMANCE</b>						
V <sub>DD</sub> Slew	Minimum V <sub>DD</sub> slew rate	V <sub>DD</sub> slew rate between 2.3 V and 2.9 V	0.25			V/ms
V <sub>RESET</sub>	Supply voltage at which device comes out of reset	For power-on reset (POR)			2.4	V
t <sub>RESET</sub>	Low-pulse duration needed at $\overline{\text{RESET}}$ pin	To reset device during normal operation	2			μs
f(PCLK)	Internal oscillator frequency	T <sub>A</sub> = 125°C, T <sub>A</sub> = 25°C	240	250	260	MHz
t <sub>retention</sub>	Retention of configuration parameters	T <sub>J</sub> = 25°C	100			Years
Write_Cycles	Number of nonvolatile erase/write cycles	T <sub>J</sub> = 25°C	20			K cycles

## PMBus/SMBus/I<sup>2</sup>C

The timing characteristics and timing diagram for the communications interface that supports I<sup>2</sup>C, SMBus and PMBus is shown below.

### I<sup>2</sup>C/SMBus/PMBus TIMING REQUIREMENTS

T<sub>A</sub> = -40°C to 85°C, 3 V < V<sub>DD</sub> < 3.6 V; typical values at T<sub>A</sub> = 25°C and V<sub>CC</sub> = 2.5 V (unless otherwise noted)

PARAMETER		TEST CONDITIONS	MIN	TYP	MAX	UNIT
FSMB	SMBus/PMBus operating frequency	Slave mode, SMBC 50% duty cycle	10		400	kHz
FI2C	I <sup>2</sup> C operating frequency	Slave mode, SCL 50% duty cycle	10		400	kHz
t <sub>(BUF)</sub>	Bus free time between start and stop		4.7			μs
t <sub>(HD:STA)</sub>	Hold time after (repeated) start		0.26			μs
t <sub>(SU:STA)</sub>	Repeated-start setup time		0.26			μs
t <sub>(SU:STO)</sub>	Stop setup time		0.26			μs
t <sub>(HD:DAT)</sub>	Data hold time	Receive mode	0			ns
t <sub>(SU:DAT)</sub>	Data setup time		50			ns
t <sub>(TIMEOUT)</sub>	Error signal/detect	See (1)			35	ms
t <sub>(LOW)</sub>	Clock low period		0.5			μs
t <sub>(HIGH)</sub>	Clock high period	See (2)	0.26		50	μs
t <sub>(LOW:SEXT)</sub>	Cumulative clock low slave extend time	See (3)			25	ms
t <sub>f</sub>	Clock/data fall time	See (4)			120	ns
t <sub>r</sub>	Clock/data rise time	See (5)			120	ns

- (1) The device times out when any clock low exceeds t<sub>(TIMEOUT)</sub>.
- (2) t<sub>(HIGH)</sub>, Max, is the minimum bus idle time. SMBC = SMBD = 1 for t > 50 ms causes reset of any transaction that is in progress. This specification is valid when the NC\_SMB control bit remains in the default cleared state (CLK[0] = 0).
- (3) t<sub>(LOW:SEXT)</sub> is the cumulative time a slave device is allowed to extend the clock cycles in one message from initial start to the stop.
- (4) Fall time t<sub>f</sub> = 0.9 V<sub>DD</sub> to (V<sub>IL</sub>MAX - 0.15)
- (5) Rise time t<sub>r</sub> = (V<sub>IL</sub>MAX - 0.15) to (V<sub>IH</sub>MIN + 0.15)

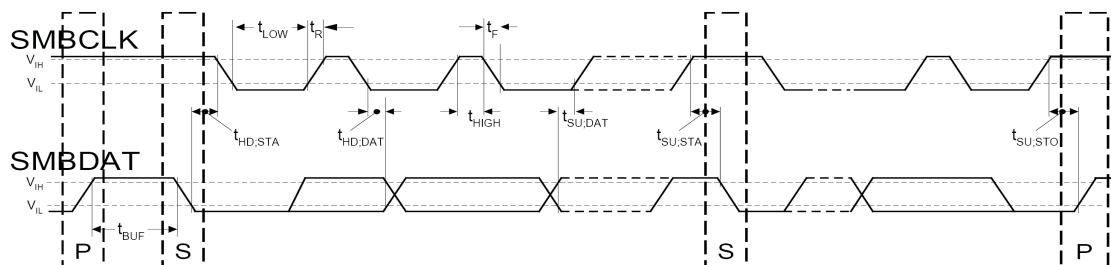

Figure 1. I<sup>2</sup>C/SMBus Timing Diagram

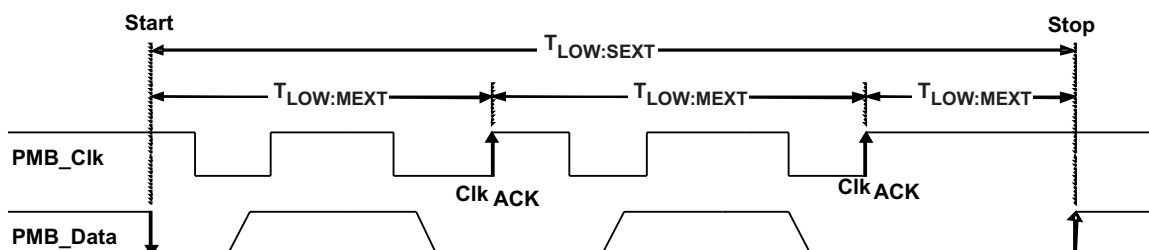

Figure 2. Bus Timing in Extended Mode

## DEVICE INFORMATION

Figure 3. UCD90124A PIN ASSIGNMENT

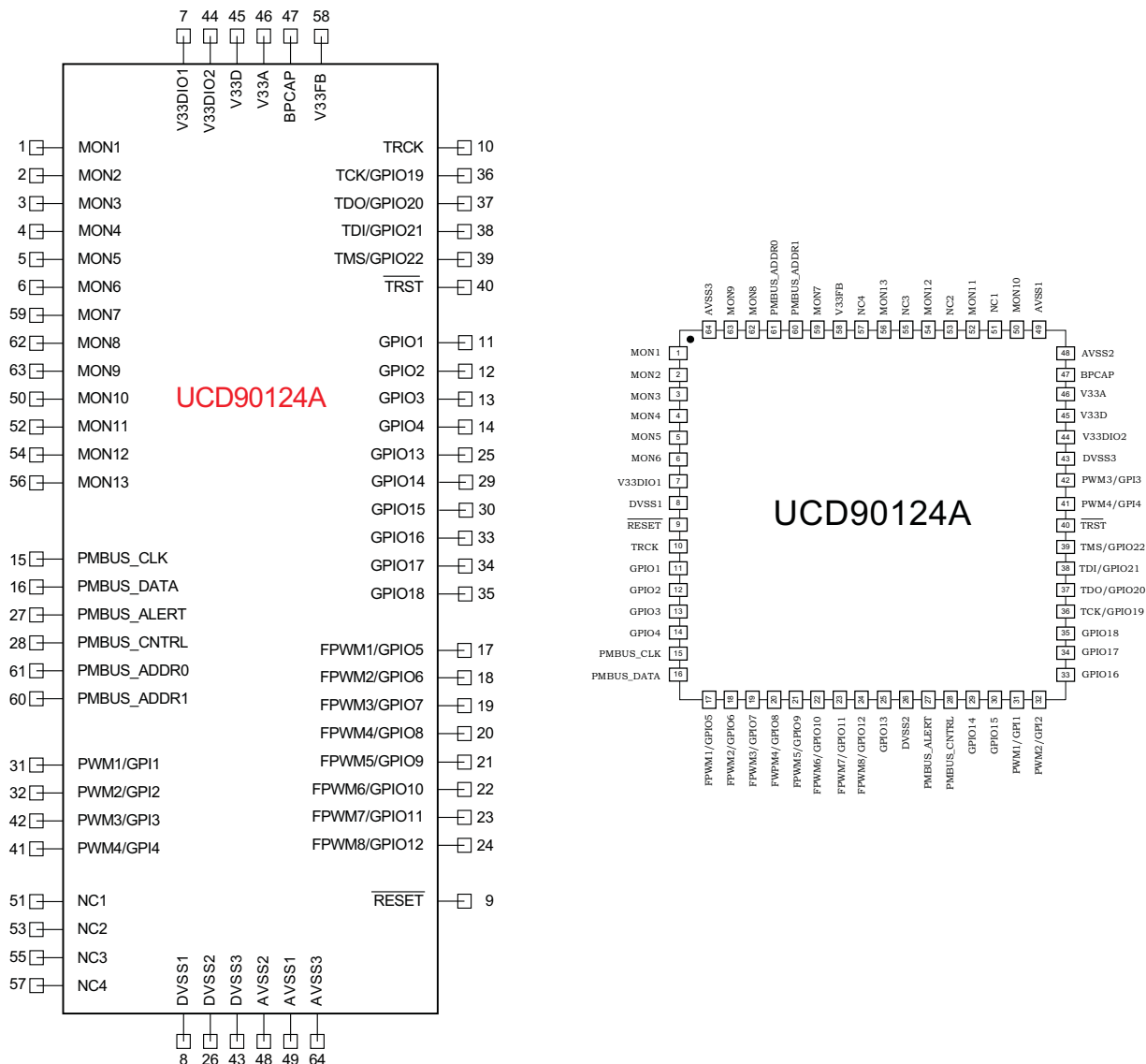

Table 1. PIN FUNCTIONS

PIN NAME	PIN NO.	I/O TYPE	DESCRIPTION
<b>ANALOG MONITOR INPUTS</b>			
MON1	1	I	Analog input (0 V–2.5 V)
MON2	2	I	Analog input (0 V–2.5 V)
MON3	3	I	Analog input (0 V–2.5 V)
MON4	4	I	Analog input (0 V–2.5 V)
MON5	5	I	Analog input (0 V–2.5 V)
MON6	6	I	Analog input (0 V–2.5 V)
MON7	59	I	Analog input (0 V–2.5 V)
MON8	62	I	Analog input (0 V–2.5 V)

**Table 1. PIN FUNCTIONS (continued)**

PIN NAME	PIN NO.	I/O TYPE	DESCRIPTION
MON9	63	I	Analog input (0 V–2.5 V)
MON10	50	I	Analog input (0 V–2.5 V)
MON11	52	I	Analog input (0 V–2.5 V)
MON12	54	I	Analog input (0 V–2.5 V)
MON13	56	I	Analog input (0 V–2.5 V)
<b>GPIO</b>			
GPIO1	11	I/O	General-purpose discrete I/O
GPIO2	12	I/O	General-purpose discrete I/O
GPIO3	13	I/O	General-purpose discrete I/O
GPIO4	14	I/O	General-purpose discrete I/O
GPIO13	25	I/O	General-purpose discrete I/O
GPIO14	29	I/O	General-purpose discrete I/O
GPIO15	30	I/O	General-purpose discrete I/O
GPIO16	33	I/O	General-purpose discrete I/O
GPIO17	34	I/O	General-purpose discrete I/O
GPIO18	35	I/O	General-purpose discrete I/O
<b>PWM OUTPUTS</b>			
FPWM1/GPIO5	17	I/O/PWM	PWM (15.259 kHz to 125 MHz) or GPIO
FPWM2/GPIO6	18	I/O/PWM	PWM (15.259 kHz to 125 MHz) or GPIO
FPWM3/GPIO7	19	I/O/PWM	PWM (15.259 kHz to 125 MHz) or GPIO
FPWM4/GPIO8	20	I/O/PWM	PWM (15.259 kHz to 125 MHz) or GPIO
FPWM5/GPIO9	21	I/O/PWM	PWM (15.259 kHz to 125 MHz) or GPIO
FPWM6/GPIO10	22	I/O/PWM	PWM (15.259 kHz to 125 MHz) or GPIO
FPWM7/GPIO11	23	I/O/PWM	PWM (15.259 kHz to 125 MHz) or GPIO
FPWM8/GPIO12	24	I/O/PWM	PWM (15.259 kHz to 125 MHz) or GPIO
PWM1/GPI1	31	I/PWM	Fixed 10-kHz PWM output or GPI
PWM2/GPI2	32	I/PWM	Fixed 1-kHz PWM output or GPI
PWM3/GPI3	42	I/PWM	PWM (0.93 Hz to 7.8125 MHz) or GPI
PWM4/GPI4	41	I/PWM	PWM (0.93 Hz to 7.8125 MHz) or GPI
<b>PMBus COMM INTERFACE</b>			
PMBUS_CLK	15	I/O	PMBus clock (must have pullup to 3.3 V)
PMBUS_DATA	16	I/O	PMBus data (must have pullup to 3.3 V)
PMBALERT#	27	O	PMBus alert, active-low, open-drain output (must have pullup to 3.3 V)
PMBUS_CNTRL	28	I	PMBus control
PMBUS_ADDR0	61	I	PMBus analog address input. Least-significant address bit
PMBUS_ADDR1	60	I	PMBus analog address input. Most-significant address bit
<b>JTAG</b>			
TRCK	10	O	Test return clock
TCK/GPIO19	36	I/O	Test clock or GPIO
TDO/GPIO20	37	I/O	Test data out or GPIO
TDI/GPIO21	38	I/O	Test data in (tie to $V_{dd}$ with 10-k $\Omega$ resistor) or GPIO
TMS/GPIO22	39	I/O	Test mode select (tie to $V_{dd}$ with 10-k $\Omega$ resistor) or GPIO
TRST	40	I	Test reset – tie to ground with 10-k $\Omega$ resistor

**Table 1. PIN FUNCTIONS (continued)**

PIN NAME	PIN NO.	I/O TYPE	DESCRIPTION
<b>INPUT POWER AND GROUNDS</b>			
RESET	9		Active-low device reset input. Hold low for at least 2 $\mu$ s to reset the device.
V33FB	58		3.3-V linear regulator feedback connection. Leave unconnected.
V33A	46		Analog 3.3-V supply. Refer to the layout guidelines section.
V33D	45		Digital core 3.3-V supply. Refer to the layout guidelines section.
V33DIO1	7		Digital I/O 3.3-V supply. Refer to the layout guidelines section.
V33DIO2	44		Digital I/O 3.3-V supply. Refer to the layout guidelines section.
BPCap	47		1.8-V bypass capacitor – tie 0.1- $\mu$ F capacitor to analog ground.
AVSS1	49		Analog ground
AVSS2	48		Analog ground
AVSS3	64		Analog ground
DVSS1	8		Digital ground
DVSS2	26		Digital ground
DVSS3	43		Digital ground
QFP ground pad	NA		Thermal pad – tie to ground plane.

## FUNCTIONAL DESCRIPTION

### TI FUSION GUI

The Texas Instruments *Fusion Digital Power Designer* is provided for device configuration. This PC-based graphical user interface (GUI) offers an intuitive I<sup>2</sup>C/PMBus interface to the device. It allows the design engineer to configure the system operating parameters for the application without directly using PMBus commands, store the configuration to on-chip nonvolatile memory, and observe system status (voltage, etc). *Fusion Digital Power Designer* is referenced throughout the data sheet as *Fusion GUI* and many sections include screenshots. The *Fusion GUI* can be downloaded from [www.ti.com](http://www.ti.com).

### PMBUS INTERFACE

The PMBus is a serial interface specifically designed to support power management. It is based on the SMBus interface that is built on the I<sup>2</sup>C physical specification. The UCD90124A supports revision 1.1 of the PMBus standard. Wherever possible, standard PMBus commands are used to support the function of the device. For unique features of the UCD90124A, MFR\_SPECIFIC commands are defined to configure or activate those features. These commands are defined in the UCD90xxx Sequencer and System Health Controller PMBUS Command Reference (SLVU352). The most current UCD90xxx PMBus Command Reference can be found within the TI Fusion Digital Power Designer software: [http://focus.ti.com/docs/toolsw/folders/print/fusion\\_digital\\_power\\_designer.html](http://focus.ti.com/docs/toolsw/folders/print/fusion_digital_power_designer.html) via the Help Menu (Help, Documentation & Help Center, Sequencers tab, Documentation section).

This document makes frequent mention of the PMBus specification. Specifically, this document is *PMBus Power System Management Protocol Specification Part II – Command Language*, Revision 1.1, dated 5 February 2007. The specification is published by the Power Management Bus Implementers Forum and is available from [www.pmbus.org](http://www.pmbus.org).

The UCD90124A is PMBus compliant, in accordance with the *Compliance* section of the PMBus specification. The firmware is also compliant with the SMBus 1.1 specification, including support for the SMBus ALERT function. The hardware can support either 100-kHz or 400-kHz PMBus operation.

## THEORY OF OPERATION

Modern electronic systems often use numerous microcontrollers, DSPs, FPGAs, and ASICs. Each device can have multiple supply voltages to power the core processor, analog-to-digital converter or I/O. These devices are typically sensitive to the order and timing of how the voltages are sequenced on and off. The UCD90124A can sequence supply voltages to prevent malfunctions, intermittent operation, or device damage caused by improper power up or power down. Appropriate handling of under- and overvoltage faults can extend system life and improve long term reliability. The UCD90124A stores power supply faults to on-chip nonvolatile flash memory for aid in system failure analysis.

Tach monitor inputs, PWM outputs and temperature measurements can be combined with a choice between two built-in fan-control algorithms to provide a stand-alone fan controller for independent operation of up to four fans.

System reliability can be improved through four-corner testing during system verification. During four-corner testing, the system is operated at the minimum and maximum expected ambient temperature and with each power supply set to the minimum and maximum output voltage, commonly referred to as margining. The UCD90124A can be used to implement accurate closed-loop margining of up to 10 power supplies.

The UCD90124A 12-rail sequencer can be used in a PMBus- or pin-based control environment. The TI Fusion GUI provides a powerful but simple interface for configuring sequencing solutions for systems with between one and 12 power supplies using 12 analog voltage-monitor inputs, four GPIs and 22 highly configurable GPIOs. A rail includes voltage, a power-supply enable and a margining output. At least one must be included in a rail definition. Once the user has defined how the power-supply rails should operate in a particular system, analog input pins and GPIOs can be selected to monitor and enable each supply ([Figure 4](#)).

Vout Config
Pin Assignment
Fault Responses and Limits
Fault Logging
Pin Selected States
System Watchdog
System Reset
Run Time Clock
Device Info
Other Config
All Config

**Rails - Monitors & Enables**
**12 of 12 Assigned**

Rail #	Rail Name	Voltage	Temperature	Current	Enable	Trim/Margin PWM	Actions
Rail #1	3p5V	Pin 1 MON1	<Click to Assign>	<Click to Assign>	Pin 11 GPIO1	Pin 17 FPWM1 GPIO5	Delete <a href="#">Configure</a>
Rail #2	3p3V	Pin 2 MON2	<Click to Assign>	<Click to Assign>	Pin 12 GPIO2	Pin 18 FPWM2 GPIO6	Delete <a href="#">Configure</a>
Rail #3	2p5V	Pin 3 MON3	<Click to Assign>	<Click to Assign>	Pin 13 GPIO3	Pin 19 FPWM3 GPIO7	Delete <a href="#">Configure</a>
Rail #4	1p8V	Pin 4 MON4	<Click to Assign>	<Click to Assign>	Pin 14 GPIO4	Pin 20 FPWM4 GPIO8	Delete <a href="#">Configure</a>
Rail #5	3p4V	Pin 5 MON5	<Click to Assign>	<Click to Assign>	Pin 25 GPIO13	<Click to Assign>	Delete <a href="#">Configure</a>
Rail #6	3p2V	Pin 6 MON6	<Click to Assign>	<Click to Assign>	Pin 33 GPIO16	<Click to Assign>	Delete <a href="#">Configure</a>
Rail #7	3p0V	Pin 59 MON7	<Click to Assign>	<Click to Assign>	Pin 34 GPIO17	<Click to Assign>	Delete <a href="#">Configure</a>
Rail #8	2p8V	Pin 62 MON8	<Click to Assign>	<Click to Assign>	Pin 35 GPIO18	<Click to Assign>	Delete <a href="#">Configure</a>
Rail #9	2p6V	Pin 63 MON9	<Click to Assign>	<Click to Assign>	Pin 36 TCK GPIO19	<Click to Assign>	Delete <a href="#">Configure</a>
Rail #10	2p4V	Pin 50 MON10	<Click to Assign>	<Click to Assign>	Pin 37 TDO GPIO20	<Click to Assign>	Delete <a href="#">Configure</a>
Rail #11	2p2V	Pin 52 MON11	<Click to Assign>	<Click to Assign>	Pin 38 TDI GPIO21	<Click to Assign>	Delete <a href="#">Configure</a>
Rail #12	2p0V	Pin 54 MON12	<Click to Assign>	<Click to Assign>	Pin 39 TMS GPIO22	<Click to Assign>	Delete <a href="#">Configure</a>

[Add Rail](#)

**GPIs - General Purpose Inputs**
**0 of 8 Assigned**

You have not configured any sequencing inputs; click the Add link below to add

[Add GPI](#)

**Logic Controlled GPOs - General Purpose Outputs with Programmable State Logic**
**0 of 12 Assigned**

You have not configured any logic controlled GPOs; click the Add link below to add

[Add Logic Controlled GPO](#)

**Command Controlled GPOs - General Purpose Outputs with Fixed State**
**0 of 22 Assigned**

You have not configured any command controlled GPOs; click the Add link below to add

[Add Command Controlled GPO](#)

**Fans**
**1 of 4 Assigned**

Fan #	Fan Name	Pins	Configuration Summary	Actions
Fan #1	Fan #1	PWM: Pin 21 FPWMS_GPIO9 Tach: Pin 31 GPI1_PWM1	Installed: yes; Tach Pules Per Rev: 2; PWM Mode: VariablePWM; Auto Calibration On; Duty On/Off/Max: 37/25/100%; Speed Fault Limit: 0.00 RPM; Fan Speed Auto Adjusted via Rail #1; 0% < 30°C; 20% < 40°C; 40% < 50°C; 60% < 60°C; 80% < 70°C; 100%; Speed Change: 8.000%; Fault Increase Speed: 0%	Delete <a href="#">Configure</a>

[Add Fan](#)

**PWMs - General Purpose Pulse-Width Modulation Outputs**
**0 of 12 Assigned**

You have not configured any PWMs; click the Add link below to add

[Add PWM](#)

**Figure 4. Fusion GUI Pin-Assignment Tab**

After the pins have been configured, other key monitoring and sequencing criteria are selected for each rail from the Vout Config tab (Figure 5):

- Nominal operating voltage (Vout)
- Undervoltage (UV) and overvoltage (OV) warning and fault limits
- Margin-low and margin-high values
- Power-good on and power-good off limits
- PMBus or pin-based sequencing control (On/Off Config)
- Rails and GPIs for Sequence On dependencies
- Rails and GPIs for Sequence Off dependencies
- Turn-on and turn-off delay timing
- Maximum time allowed for a rail to reach POWER\_GOOD\_ON or POWER\_GOOD\_OFF after being enabled

or disabled

- Other rails to turn off in case of a fault on a rail (fault-shutdown slaves)

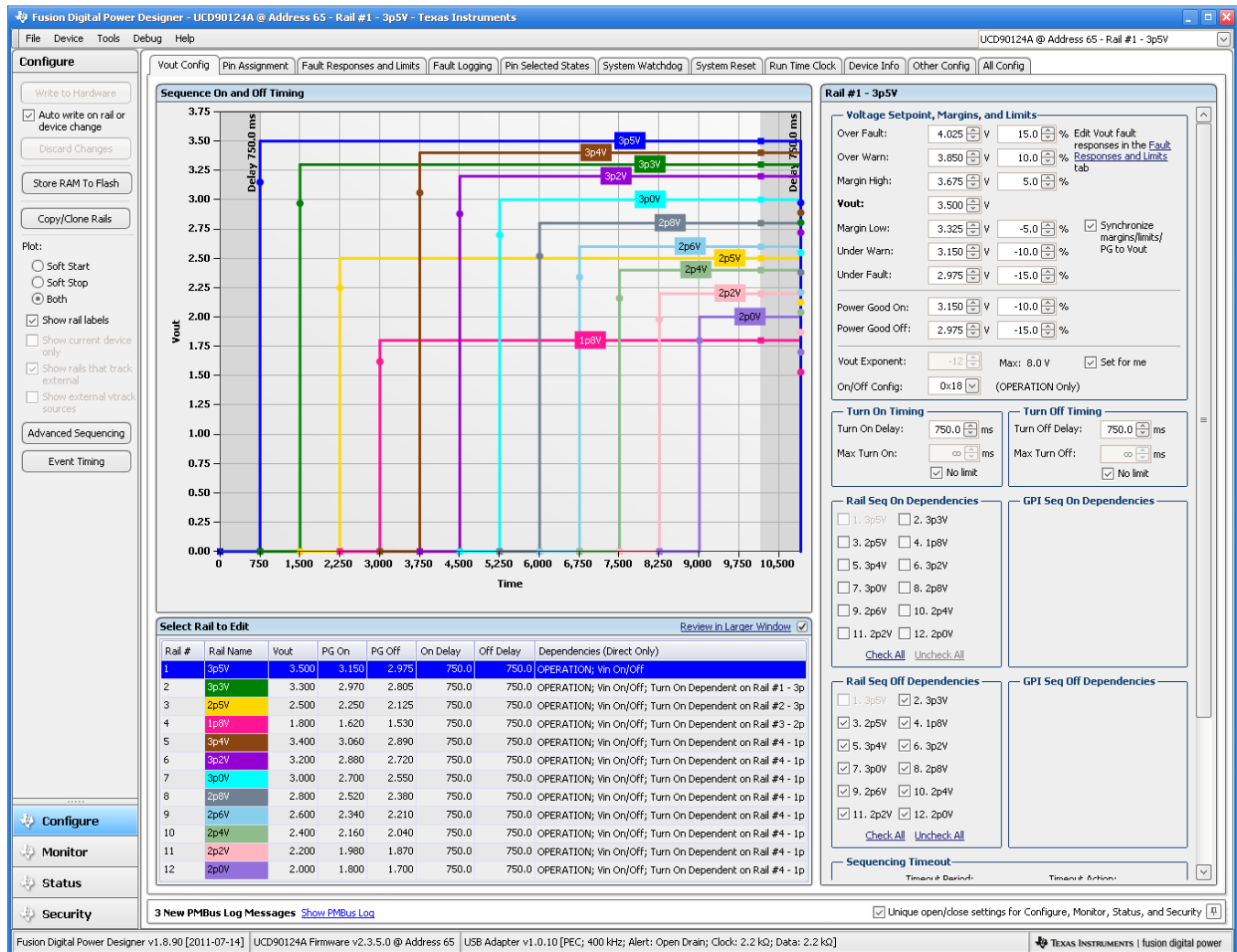

Figure 5. Fusion GUI V<sub>OUT</sub>-Config Tab

The **Synchronize margins/limits/PG to Vout** checkbox is an easy way to change the nominal operating voltage of a rail and also update all of the other limits associated with that rail according to the percentages shown to the right of each entry.

The plot in the upper left section of Figure 5 shows a simulation of the overall sequence-on and sequence-off configuration, including the nominal voltage, the turnon and turnoff delay times, the power-good on and power-good off voltages and any timing dependencies between the rails.

After a rail voltage has reached its POWER\_GOOD\_ON voltage and is considered to be in regulation, it is compared against two UV and two OV thresholds in order to determine if a warning or fault limit has been exceeded. If a fault is detected, the UCD90124A responds based on a variety of flexible, user-configured options. Faults can cause rails to restart, shut down immediately, sequence off using turnoff delay times or shut down a group of rails and sequence them back on. Different types of faults can result in different responses.

Fault responses, along with a number of other parameters including user-specific manufacturing information and external scaling and offset values, are selected in the different tabs within the Configure function of the Fusion GUI. Once the configuration satisfies the user requirements, it can be written to device SRAM if Fusion GUI is connected to a UCD90124A using an I<sup>2</sup>C/PMBus. SRAM contents can then be stored to data flash memory so that the configuration remains in the device after a reset or power cycle.

The *Fusion GUI* Monitor page has a number of options, including a device dashboard and a system dashboard, for viewing and controlling device and system status.

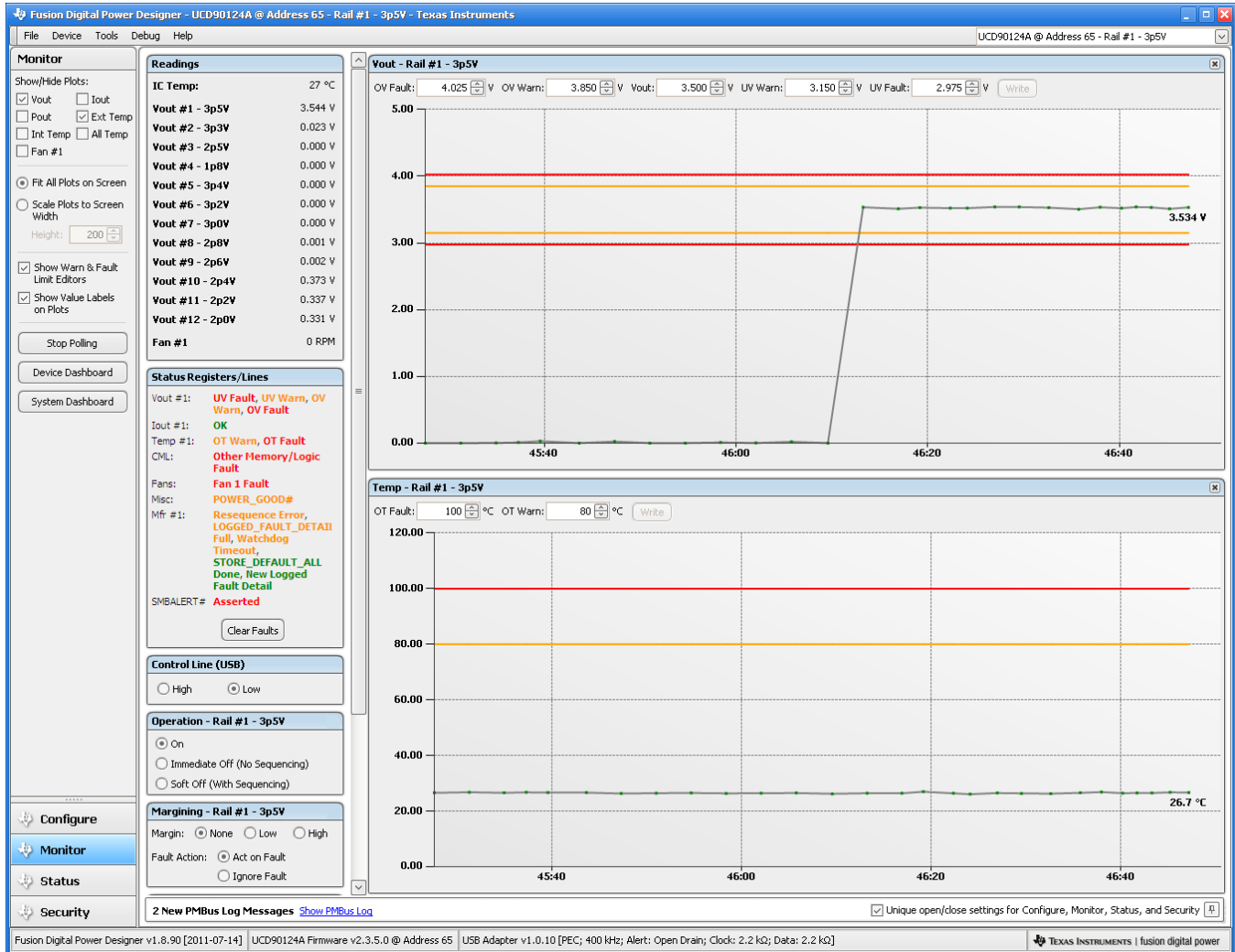

Figure 6. Fusion GUI Monitor Page

The UCD90124A also has status registers for each rail and the capability to log faults to flash memory for use in system troubleshooting. This is helpful in the event of a power-supply or system failure. The status registers (Figure 7) and the fault log (Figure 8) are available in the *Fusion GUI*. See the *UCD90xxx Sequencer and System Health Controller PMBus Command Reference (SLVU352)* and the PMBus Specification for detailed descriptions of each status register and supported PMBus commands.

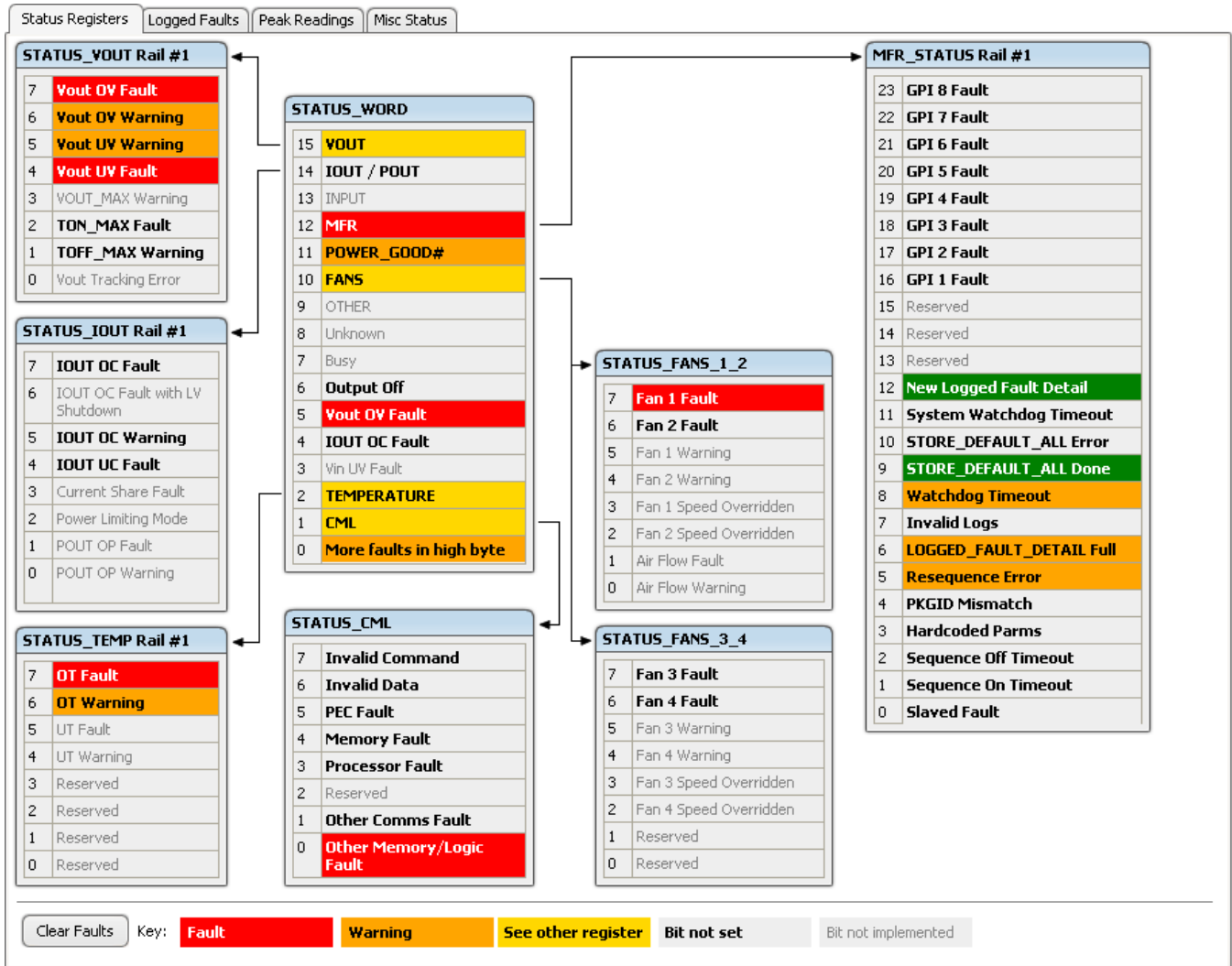

Figure 7. Fusion GUI Rail-Status Register

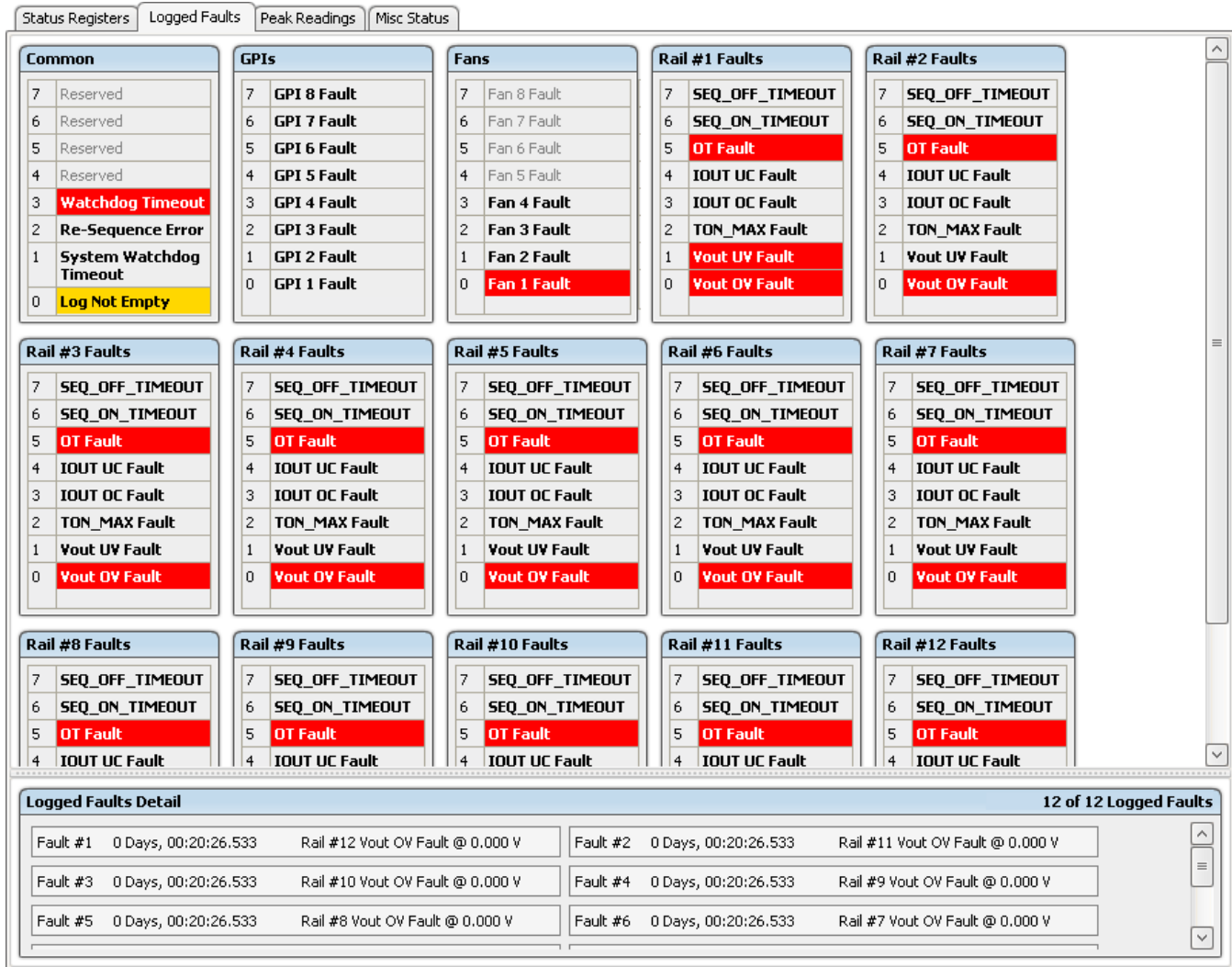

Figure 8. Fusion GUI Flash-Error Log (Logged Faults)

## POWER-SUPPLY SEQUENCING

The UCD90124A can control the turn-on and turn-off sequencing of up to 12 voltage rails by using a GPIO to set a power-supply enable pin high or low. In PMBus-based designs, the system PMBus master can initiate a sequence-on event by asserting the PMBUS\_CNTRL pin or by sending the OPERATION command over the I<sup>2</sup>C serial bus. In pin-based designs, the PMBUS\_CNTRL pin can also be used to sequence-on and sequence-off.

The auto-enable setting ignores the OPERATION command and the PMBUS\_CNTRL pin. Sequence-on is started at power up after any dependencies and time delays are met for each rail. A rail is considered to be on or within regulation when the measured voltage for that rail crosses the power-good on (POWER\_GOOD\_ON<sup>(1)</sup>) limit. The rail is still in regulation until the voltage drops below power-good off (POWER\_GOOD\_OFF). In the case that there isn't voltage monitoring set for a given rail, that rail is considered ON if it is commanded on (either by OPERATION command, PMBUS\_CNTRL pin, or auto-enable) and (TON\_DELAY + TON\_MAX\_FAULT\_LIMIT) time passes. Also, a rail is considered OFF if that rail is commanded OFF and (TOFF\_DELAY + TOFF\_MAX\_WARN\_LIMIT) time passes

(1) In this document, configuration parameters such as Power Good On are referred to using Fusion GUI names. The UCD90xxx Sequencer and System Health Controller PMBus Command Reference name is shown in parentheses (POWER\_GOOD\_ON) the first time the parameter appears.

## Turn-on Sequencing

The following sequence-on options are supported for each rail:

- Monitor only – do not sequence-on
- Fixed delay time (TON\_DELAY) after an OPERATION command to turn on
- Fixed delay time after assertion of the PMBUS\_CNTRL pin
- Fixed time after one or a group of parent rails achieves regulation (POWER\_GOOD\_ON)
- Fixed time after a designated GPI has reached a user-specified state
- Any combination of the previous options

The maximum TON\_DELAY time is 3276 ms.

## Turn-off Sequencing

The following sequence-off options are supported for each rail:

- Monitor only – do not sequence-off
- Fixed delay time (TOFF\_DELAY) after an OPERATION command to turn off
- Fixed delay time after deassertion of the PMBUS\_CNTRL pin
- Fixed time after one or a group of parent rails drop below regulation (POWER\_GOOD\_OFF)
- Fixed delay time in response to an undervoltage, overvoltage, or max turn-on fault on the rail
- Fixed delay time in response to a fault on a different rail when set as a fault shutdown slave to the faulted rail
- Fixed delay time in response to a GPI reaching a user-specified state
- Any combination of the previous options

The maximum TOFF\_DELAY time is 3276 ms.

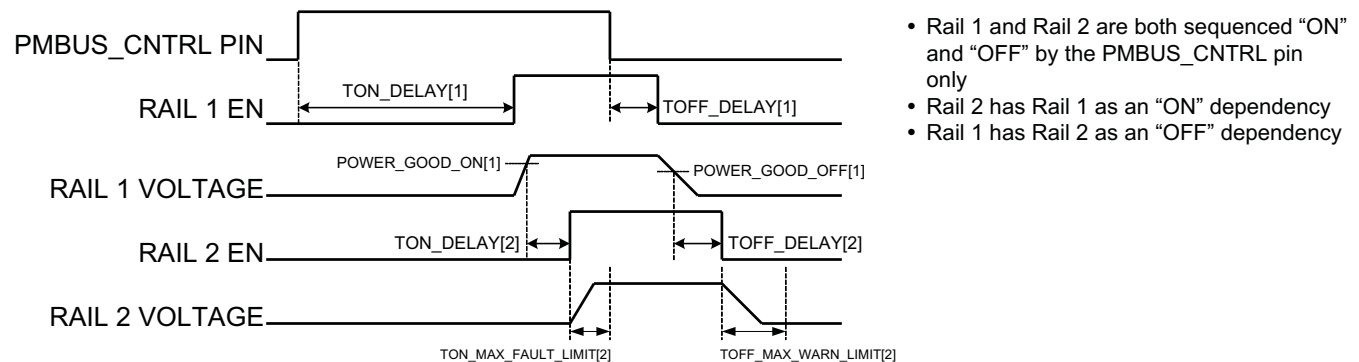

Figure 9. Sequence-on and Sequence-off Timing

## Sequencing Configuration Options

In addition to the turn-on and turn-off sequencing options, the time between when a rail is enabled and when the monitored rail voltage must reach its power-good-on setting can be configured using max turn-on (TON\_MAX\_FAULT\_LIMIT). Max turn-on can be set in 1-ms increments. A value of 0 ms means that there is no limit and the device can try to turn on the output voltage indefinitely.

Rails can be configured to turn off immediately or to sequence-off according to rail and GPI dependencies, and user-defined delay times. A sequenced shutdown is configured by selecting the appropriate rail and GPI dependencies, and turn-off delay (TOFF\_DELAY) times for each rail. The turn-off delay times begin when the PMBUS\_CNTRL pin is deasserted, when the PMBus OPERATION command is used to give a soft-stop command, or when a fault occurs on a rail that has other rails set as fault-shutdown slaves.

Shutdowns on one rail can initiate shutdowns of other rails or controllers. In systems with multiple UCD90124As, it is possible for each controller to be both a master and a slave to another controller.

## PIN SELECTED RAIL STATES

This feature allows with the use of up to 3 GPIs to enable and disable any rail. This is useful for implementing system low-power modes and the Advanced Configuration and Power Interface (ACPI) specification that is used for operating system directed power management in servers and PCs. In up to 8 system states, the power system designer can define which rails are on and which rails are off. If a new state is presented on the input pins, and a rail is required to change state, it will do so with regard to its sequence-on or sequence-off dependencies.

The OPERATION command is modified when this function causes a rail to change its state. This means that the ON\_OFF\_CONFIG for a given rail must be set to use the OPERATION command for this function to have any effect on the rail state. The first 3 pins configured with the GPI\_CONFIG command are used to select 1 of 8 system states. Whenever the device is reset, these pins are sampled and the system state, if enabled, will be used to update each rail state. When selecting a new system state, changes to the status of the GPIs must not take longer than 1 microsecond. See the *UCD90xxx Sequencer and System Health Controller PMBus Command Reference* for complete configuration settings of PIN\_SELECTED\_RAIL\_STATES.

**Table 2. GPI Selection of System States**

GPI 2 State	GPI 1 State	GPI 0 State	System State
NOT Asserted	NOT Asserted	NOT Asserted	0
NOT Asserted	NOT Asserted	Asserted	1
NOT Asserted	Asserted	NOT Asserted	2
NOT Asserted	Asserted	Asserted	3
Asserted	NOT Asserted	NOT Asserted	4
Asserted	NOT Asserted	Asserted	5
Asserted	Asserted	NOT Asserted	6
Asserted	Asserted	Asserted	7

## MONITORING

The UCD90124A has 13 monitor input pins (MONx) that are multiplexed into a 2.5V referenced 12-bit ADC. The monitor pins can be configured so that they can measure voltage signals to report voltage, current and temperature type measurements. A single rail can include all three measurement types, each monitored on separate MON pins. If a rail has both voltage and current assigned to it, then the user can calculate power for the rail. Digital filtering applied to each MON input depends on the type of signal. Voltage inputs have no filtering. Current and temperature inputs have a low-pass filter.

Although the monitor results can be reported with a resolution of about 15  $\mu$ V, the real conversion resolution of 610  $\mu$ V is fixed by the 2.5-V reference and the 12-bit ADC.

**Table 3. Voltage Range and Resolution**

VOLTAGE RANGE (Volts)	RESOLUTION (millivolts)
0 to 127.99609	3.90625
0 to 63.99805	1.95313
0 to 31.99902	0.97656
0 to 15.99951	0.48824
0 to 7.99976	0.24414
0 to 3.99988	0.12207
0 to 1.99994	0.06104
0 to 0.99997	0.03052

## VOLTAGE MONITORING

Up to 12 rail voltages can be monitored using the analog input pins. The input voltage range is 0 V–2.5 V for MON pins 1-6, 59, 62 and 63. Pins 50, 52, 54 and 56 can measure down to 0.2 V. Any voltage between 0 V and 0.2 V on these pins is read as 0.2 V. External resistors can be used to attenuate voltages higher than 2.5 V.

The ADC operates continuously, requiring 3.89  $\mu$ s to convert a single analog input. Each rail is sampled by the sequencing and monitoring algorithm every 400  $\mu$ s. The maximum source impedance of any sampled voltage should be less than 4 k $\Omega$ . The source impedance limit is particularly important when a resistor-divider network is used to lower the voltage applied to the analog input pins.

MON1 - MON6 can be configured using digital hardware comparators, which can be used to achieve faster fault responses. Each hardware comparator has four thresholds (two UV (Fault and Warning) and two OV (Fault and Warning)). The hardware comparators respond to UV or OV conditions in about 80  $\mu$ s (faster than 400  $\mu$ s for the ADC inputs) and can be used to disable rails or assert GPOs. The only fault response available for the hardware comparators is to shut down immediately.

An internal 2.5-V reference is used by the ADC. The ADC reference has a tolerance of  $\pm$ 0.5% between 0°C and 125°C and a tolerance of  $\pm$ 1% between –40°C and 125°C. An external voltage divider is required for monitoring voltages higher than 2.5 V. The nominal rail voltage and the external scale factor can be entered into the *Fusion GUI* and are used to report the actual voltage being monitored instead of the ADC input voltage. The nominal voltage is used to set the range and precision of the reported voltage according to [Table 3](#).

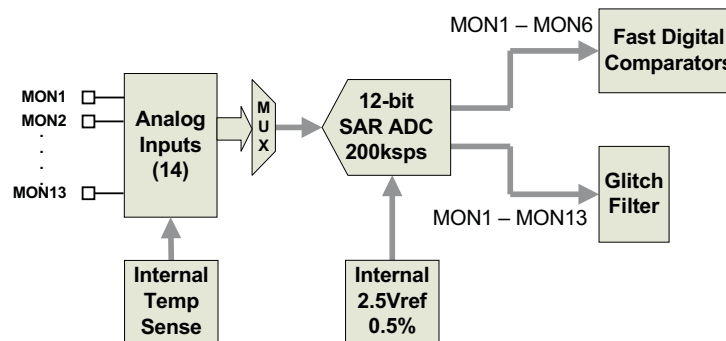

Figure 10. Voltage Monitoring Block Diagram

Although the monitor results can be reported with a resolution of about 15  $\mu$ V, the real conversion resolution of 610  $\mu$ V is fixed by the 2.5-V reference and the 12-bit ADC.

## CURRENT MONITORING

Current can be monitored using the analog inputs. External circuitry, see [Figure 11](#), must be used in order to convert the current to a voltage within the range of the UCD90124A MONx input being used.

If a monitor input is configured as a current, the measurements are smoothed by a sliding-average digital filter. The current for 1 rail is measured every 200 $\mu$ s. If the device is programmed to support 10 rails (independent of current not being monitored at all rails), then each rail's current will get measured every 2ms. The current calculation is done with a sliding average using the last 4 measurements. The filter reduces the probability of false fault detections, and introduces a small delay to the current reading. If a rail is defined with a voltage monitor and a current monitor, then monitoring for undercurrent warnings begins once the rail voltage reaches POWER\_GOOD\_ON. If the rail does not have a voltage monitor, then current monitoring begins after TON\_DELAY.

The device supports multiple PMBus commands related to current, including READ\_IOUT, which reads external currents from the MON pins; IOUT\_OC\_FAULT\_LIMIT, which sets the overcurrent fault limit; IOUT\_OC\_WARN\_LIMIT, which sets the overcurrent warning limit; and IOUT\_UC\_FAULT\_LIMIT, which sets the undercurrent fault limit. The UCD90xxx Sequencer and System Health Controller PMBus Command Reference contains a detailed description of how current fault responses are implemented using PMBus commands.

IOUT\_CAL\_GAIN is a PMBus command that allows the scale factor of an external current sensor and any amplifiers or attenuators between the current sensor and the MON pin to be entered by the user in milliohms. IOUT\_CAL\_OFFSET is the current that results in 0 V at the MON pin. The combination of these PMBus commands allows current to be reported in amperes. The example below using the INA196 would require programming IOUT\_CAL\_GAIN to  $R_{\text{sense}}(\text{m}\Omega) \times 20$ .

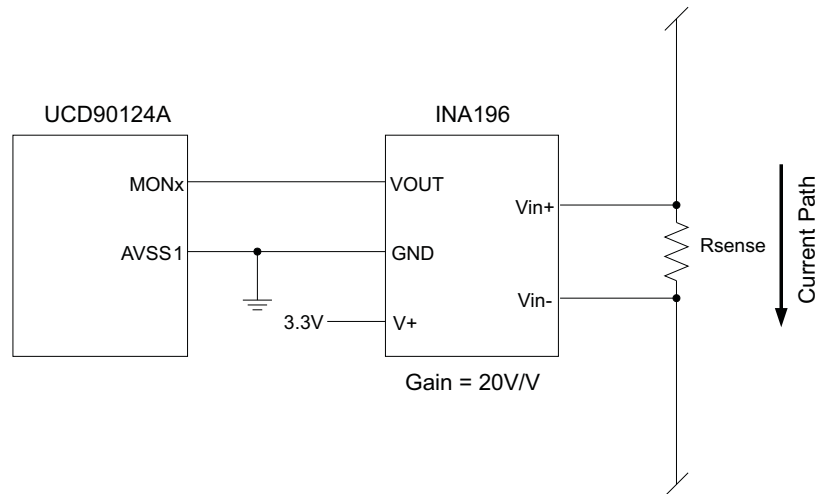

**Figure 11. Current Monitoring Circuit Example Using the INA196**

## REMOTE TEMPERATURE MONITORING AND INTERNAL TEMPERATURE SENSOR

The UCD90124A has support for internal and remote temperature sensing. The internal temperature sensor requires no calibration and can report the device temperature via the PMBus interface. The remote temperature sensor can report the remote temperature by using a configurable gain and offset for the type of sensor that is used in the application such as a linear temperature sensor (LTS) connected to the analog inputs.

External circuitry must be used in order to convert the temperature to a voltage within the range of the UCD90124A MONx input being used.

If an input is configured as a temperature, the measurements are smoothed by a sliding average digital filter. The temperature for 1 rail is measured every 100ms. If the device is programmed to support 10 rails (independent of temperature not being monitored at all rails), then each rail's temperature will get measured every 1s. The temperature calculation is done with a sliding average using the last 16 measurements. The filter reduces the probability of false fault detections, and introduces a small delay to the temperature reading. The internal device temperature is measured using a silicon diode sensor with an accuracy of  $\pm 5^{\circ}\text{C}$  and is also monitored using the ADC. Temperature monitoring begins immediately after reset and initialization.

The device supports multiple PMBus commands related to temperature, including READ\_TEMPERATURE\_1, which reads the internal temperature; READ\_TEMPERATURE\_2, which reads external temperatures; and OT\_FAULT\_LIMIT and OT\_WARN\_LIMIT, which set the overtemperature fault and warning limit. The UCD90xxx Sequencer and System Health Controller PMBus Command Reference contains a detailed description of how temperature-fault responses are implemented using PMBus commands.

TEMPERATURE\_CAL\_GAIN is a PMBus command that allows the scale factor of an external temperature sensor (Figure 12) and any amplifiers or attenuators between the temperature sensor and the MON pin to be entered by the user in  $^{\circ}\text{C}/\text{V}$ . TEMPERATURE\_CAL\_OFFSET is the temperature that results in 0 V at the MON pin. The combination of these PMBus commands allows temperature to be reported in degrees Celsius.

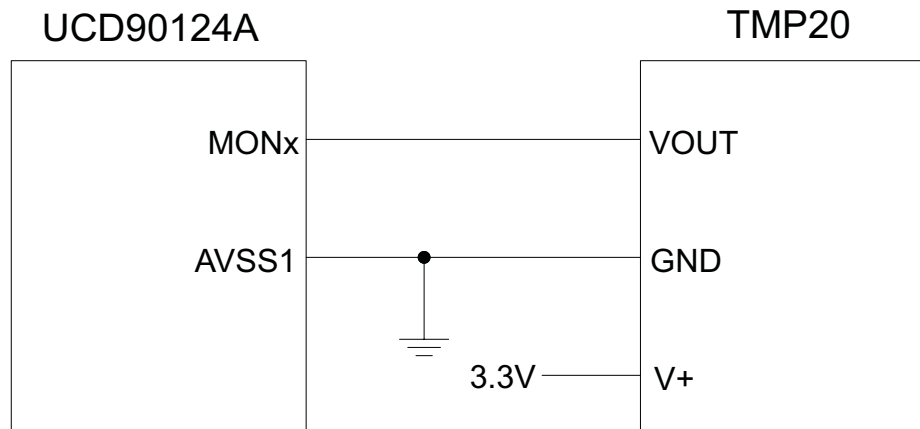

$$V_{out} = -11.67\text{mV}/^{\circ}\text{C} \times T + 1.8583$$

at  $-40^{\circ}\text{C} < T < 85^{\circ}\text{C}$

Figure 12. Remote Temperature Monitoring Circuit Example Using the TMP20

### TEMPERATURE BY HOST INPUT

If the host system has the option of not using the temperature-sensing capability of the UCD90124A, it can still provide the desired temperature to the UCD90124A through PMBus. The host may have temperature measurements available through I2C or SPI interfaced temperature sensors. The UCD90124A would use the temperature given by the host in place of an external temperature measurement for a given rail. The temperature provided by the host would still be used for detecting overtemperature warnings or faults, logging peak temperatures, input to Boolean logic-builder functions, and feedback for the fan-control algorithms. To write a temperature associated with a rail, the PMBus command used is the READ\_TEMPERATURE\_2 command. If the host writes that command, the value written will be used as the temperature until another value is written. This is true whether a monitor pin was assigned to the temperature or not. When there is a monitor pin associated with the temperature, once READ\_TEMPERATURE\_2 is written, the monitor pin is not used again until the part is reset. When there is not a monitor pin associated with the temperature, the internal temperature sensor is used for the temperature until the READ\_TEMPERATURE\_2 command is written.

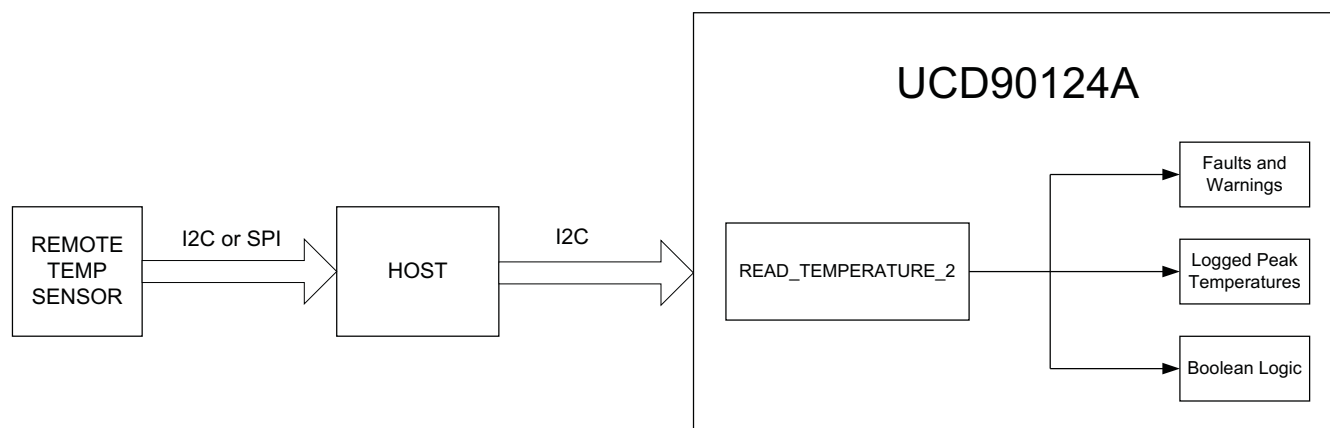

Figure 13. Host Writing Temperature to UCD90124A

### FAULT RESPONSES AND ALERT PROCESSING

The UCD90124A monitors whether the rail stays within a window of normal operation. There are two

# UCD90124A

SLVSN8 – JANUARY 2012

www.ti.com

programmable warning levels (under and over) and two programmable fault levels (under and over). When any monitored voltage goes outside of the warning or fault window, the PMBALERT# pin is asserted immediately, and the appropriate bits are set in the PMBus status registers (see Figure 7). Detailed descriptions of the status registers are provided in the *UCD90xxx Sequencer and System Health Controller PMBus Command Reference* and the *PMBus Specification*.

A programmable glitch filter can be enabled or disabled for each MON input. A glitch filter for an input defined as a voltage can be set between 0 and 102 ms with 400-μs resolution.

Fault-response decisions are based on results from the 12-bit ADC. The device cycles through the ADC results and compares them against the programmed limits. The time to respond to an individual event is determined by when the event occurs within the ADC conversion cycle and the selected fault response.

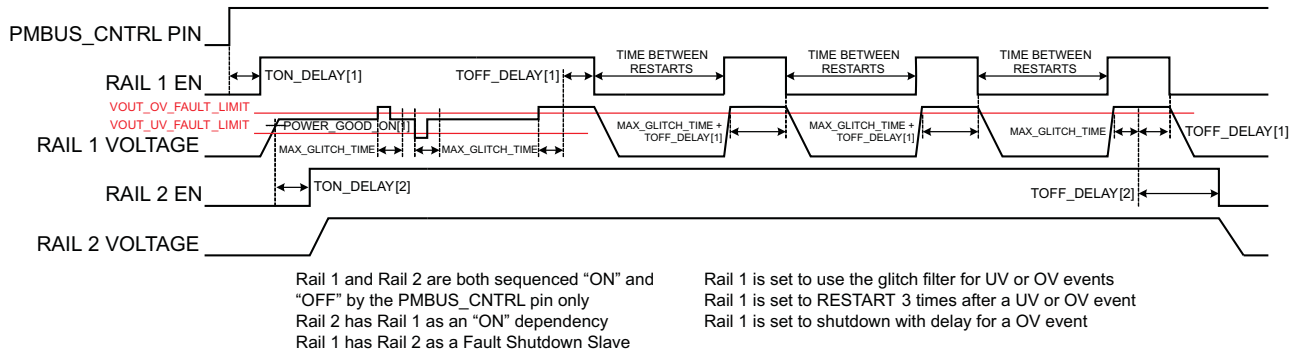

**Figure 14. Sequencing and Fault-Response Timing**

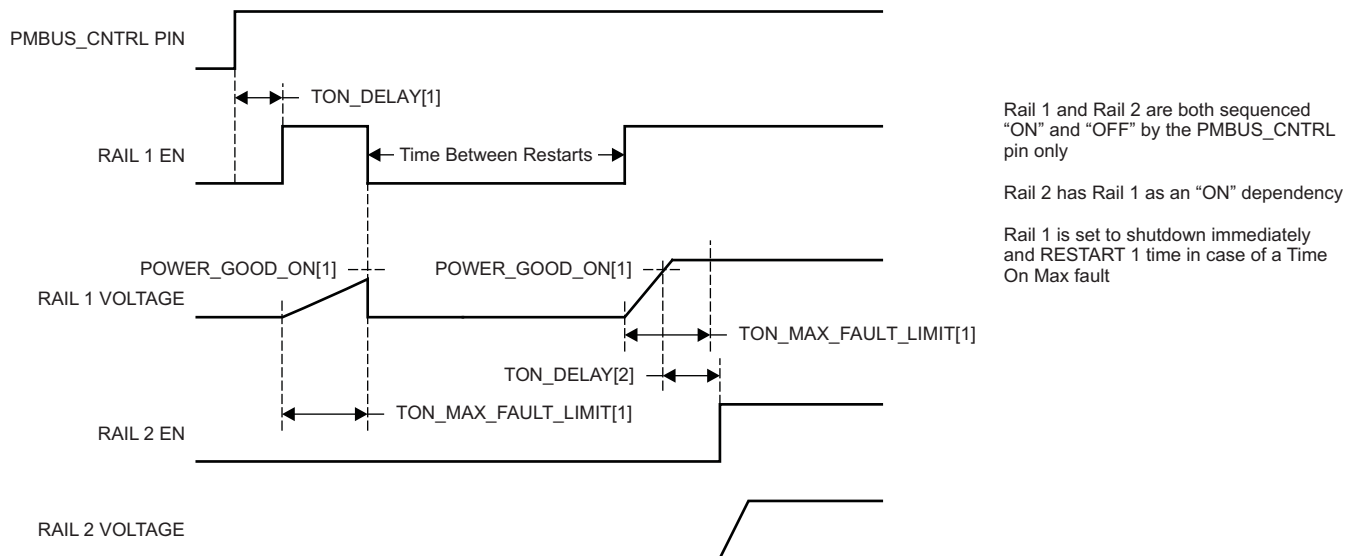

**Figure 15. Maximum Turn-on Fault**

The configurable fault limits are:

**TON\_MAX\_FAULT** – Flagged if a rail that is enabled does not reach the POWER\_GOOD\_ON limit within the configured time

**VOUT\_UV\_WARN** – Flagged if a voltage rail drops below the specified UV warning limit after reaching the POWER\_GOOD\_ON setting

**VOUT\_UV\_FAULT** – Flagged if a rail drops below the specified UV fault limit after reaching the POWER\_GOOD\_ON setting

**VOUT\_OV\_WARN** – Flagged if a rail exceeds the specified OV warning limit at any time during startup or operation

**VOUT\_OV\_FAULT** – Flagged if a rail exceeds the specified OV fault limit at any time during startup or operation

**MAX\_TOFF\_WARN** – Flagged if a rail that is commanded to shut down does not reach 12.5% of the nominal rail voltage within the configured time

Faults are more serious than warnings. The PMBALERT# pin is always asserted immediately if a warning or fault occurs. If a warning occurs, the following takes place:

#### Warning Actions

- Immediately assert the PMBALERT# pin
- Status bit is flagged
- Assert a GPIO pin (optional)
- Warnings are not logged to flash

A number of fault response options can be chosen from:

#### Fault Responses

- *Continue Without Interruption*: Flag the fault and take no action
- *Shut Down Immediately*: Shut down the faulted rail immediately and restart according to the rail configuration
- *Shut Down using TOFF\_DELAY*: If a fault occurs on a rail, exhaust whatever retries are configured. If the rail does not come back, schedule the shutdown of this rail and all fault-shutdown slaves. All selected rails, including the faulty rail, are sequenced off according to their sequence-off dependencies and T\_OFF\_DELAY times. If Do Not Restart is selected, then sequence off all selected rails when the fault is detected.

#### Restart

- *Do Not Restart*: Do not attempt to restart a faulted rail after it has been shut down.
- *Restart Up To N Times*: Attempt to restart a faulted rail up to 14 times after it has been shut down. The time between restarts is measured between when the rail enable pin is deasserted (after any glitch filtering and turn-off delay times, if configured to observe them) and then reasserted. It can be set between 0 and 1275 ms in 5-ms increments.
- *Restart Continuously*: Same as *Restart Up To N Times* except that the device continues to restart until the fault goes away, it is commanded off by the specified combination of PMBus OPERATION command and PMBUS\_CNTRL pin status, the device is reset, or power is removed from the device.
- *Shut Down Rails and Sequence On (Re-sequence)*: Shut down selected rails immediately or after continue-operation time is reached and then sequence-on those rails using sequence-on dependencies and T\_ON\_DELAY times.

### SHUT DOWN ALL RAILS AND SEQUENCE ON (RESEQUENCE)

In response to a fault, or a RESEQUENCE command, the UCD90124A can be configured to turn off a set of rails and then sequence them back on. To sequence all rails in the system, then all rails must be selected as fault-shutdown slaves of the faulted rail. The rails designated as fault-shutdown slaves will do soft shutdowns regardless of whether the faulted rail is set to stop immediately or stop with delay. Shut-down-all-rails and sequence-on are not performed until retries are exhausted for a given fault.

While waiting for the rails to turn off, an error is reported if any of the rails reaches its TOFF\_MAX\_WARN\_LIMIT. There is a configurable option to continue with the resequencing operation if this occurs. After the faulted rail and

## UCD90124A

SLVSN8 – JANUARY 2012

[www.ti.com](http://www.ti.com)

fault-shutdown slaves sequence-off, the UCD90124A waits for a programmable delay time between 0 and 1275 ms in increments of 5 ms and then sequences-on the faulted rail and fault-shutdown slaves according to the start-up sequence configuration. This is repeated until the faulted rail and fault-shutdown slaves successfully achieve regulation or for a user-selected 1, 2, 3, or 4 times. If the resequence operation is successful, the resequence counter is reset if all of the rails that were resequenced maintain normal operation for one second.

Once shut-down-all-rails and sequence-on begin, any faults on the fault-shutdown slave rails are ignored. If there are two or more simultaneous faults with different fault-shutdown slaves, the more conservative action is taken. For example, if a set of rails is already on its second resequence and the device is configured to resequence three times, and another set of rails enters the resequence state, that second set of rails is only resequenced once. Another example – if one set of rails is waiting for all of its rails to shut down so that it can resequence, and another set of rails enters the resequence state, the device now waits for all rails from both sets to shut down before resequencing.

### GPIOs

The UCD90124A has 22 GPIO pins that can function as either inputs or outputs. Each GPIO has configurable output mode options including open-drain or push-pull outputs that can be actively driven to 3.3 V or ground. There are an additional four pins that can be used as either inputs or PWM outputs but not as GPOs. [Table 4](#) lists possible uses for the GPIO pins and the maximum number of each type for each use. GPIO pins can be dependents in sequencing and alarm processing. They can also be used for system-level functions such as external interrupts, power-goods, resets, or for the cascading of multiple devices. GPOs can be sequenced up or down by configuring a rail without a MON pin but with a GPIO set as an enable.

**Table 4. GPIO Pin Configuration Options**

PIN NAME	PIN	RAIL EN (12 MAX)	GPI (8 MAX)	GPO (12 MAX)	PWM OUT (12 MAX)	MARGIN PWM (10 MAX)
FPWM1/GPIO5	17	X	X	X	X	X
FPWM2/GPIO6	18	X	X	X	X	X
FPWM3/GPIO7	19	X	X	X	X	X
FPWM4/GPIO8	20	X	X	X	X	X
FPWM5/GPIO9	21	X	X	X	X	X
FPWM6/GPIO10	22	X	X	X	X	X
FPWM7/GPIO11	23	X	X	X	X	X
FPWM8/GPIO12	24	X	X	X	X	X
GPI1/PWM1	31		X		X	
GPI2/PWM2	32		X		X	
GPI3/PWM3	42		X		X	X
GPI4/PWM4	41		X		X	X
GPIO1	11	X	X	X		
GPIO2	12	X	X	X		
GPIO3	13	X	X	X		
GPIO4	14	X	X	X		
GPIO13	25	X	X	X		
GPIO14	29	X	X	X		
GPIO15	30	X	X	X		
GPIO16	33	X	X	X		
GPIO17	34	X	X	X		
GPIO18	35	X	X	X		
TCK/GPIO19	36	X	X	X		
TDO/GPIO20	37	X	X	X		
TDI/GPIO21	38	X	X	X		
TMS/GPIO22	39	X	X	X		

## GPIO Control

The GPIOs when configured as outputs can be controlled by PMBus commands or through logic defined in internal Boolean function blocks. Controlling GPOs by PMBus commands (GPIO\_SELECT and GPIO\_CONFIG) can be used to have control over LEDs, enable switches, etc. with the use of an I2C interface. See the UCD90xxx Sequencer and System Health Controller PMBus Command Reference for details on controlling a GPO using PMBus commands.

## GPO Dependencies

GPIOs can be configured as outputs that are based on Boolean combinations of up to two ANDs all ORed together (Figure 16). Inputs to the logic blocks can include the first 8 defined GPOs, GPIOs and rail-status flags. One rail status type is selectable as an input for each AND gate in a Boolean block. For a selected rail status, the status flags of all active rails can be included as inputs to the AND gate. *\_LATCH* rail-status types stay asserted until cleared by a MFR PMBus command or by a specially configured GPIO pin. The different rail-status types are shown in Table 5. See the *UCD90xxx Sequencer and System Health Controller PMBus Command Reference* for complete definitions of rail-status types. The GPO response can be configured to have a delayed assertion or deassertion.

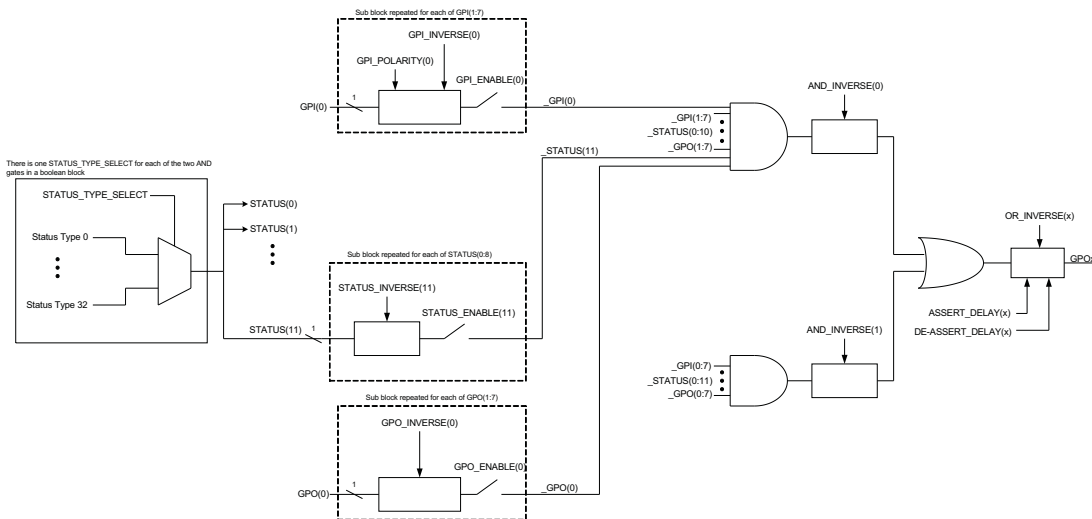

Figure 16. Boolean Logic Combinations

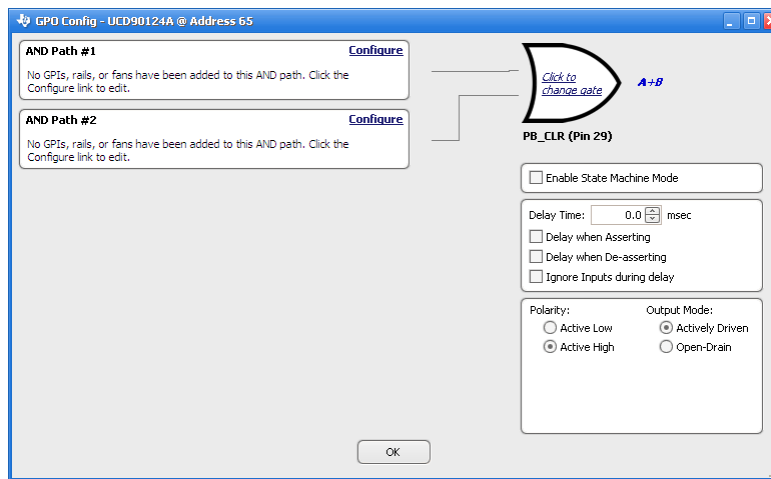

Figure 17. Fusion Boolean Logic Builder

**Table 5. Rail-Status Types for Boolean Logic**

Rail-Status Types		
POWER_GOOD	IOUT_UC_FAULT	TON_MAX_FAULT_LATCH
MARGIN_EN	TEMP_OT_FAULT	TOFF_MAX_WARN_LATCH
MRG_LOW_nHIGH	TEMP_OT_WARN	IOUT_OC_FAULT_LATCH
VOUT_OV_FAULT	SEQ_ON_TIMEOUT	IOUT_OC_WARN_LATCH
VOUT_OV_WARN	SEQ_OFF_TIMEOUT	IOUT_UC_FAULT_LATCH
VOUT_UV_WARN	FAN_FAULT	TEMP_OT_FAULT_LATCH
VOUT_UV_FAULT	SYSTEM_WATCHDOG_TIMEOUT	TEMP_OT_WARN_LATCH
TON_MAX_FAULT	VOUT_OV_FAULT_LATCH	SEQ_ON_TIMEOUT_LATCH
TOFF_MAX_WARN	VOUT_OV_WARN_LATCH	SEQ_OFF_TIMEOUT_LATCH
IOUT_OC_FAULT	VOUT_UV_WARN_LATCH	SYSTEM_WATCHDOG_TIMEOUT_LATCH
IOUT_OC_WARN	VOUT_UV_FAULT_LATCH	

### GPO Delays

The GPOs can be configured so that they manifest a change in logic with a delay on assertion, deassertion, both or none. GPO behavior using delays will have different effects depending if the logic change occurs at a faster rate than the delay. On a normal delay configuration, if the logic for a GPO changes to a state and reverts back to previous state within the time of a delay then the GPO will not manifest the change of state on the pin. In [Figure 18](#) the GPO is set so that it follows the GPI with a 3ms delay at assertion and also at de-assertion. When the GPI first changes to high logic state, the state is maintained for a time longer than the delay allowing the GPO to follow with appropriate logic state. The same goes for when the GPI returns to its previous low logic state. The second time that the GPI changes to a high logic state it returns to low logic state before the delay time expires. In this case the GPO does not change state. A delay configured in this manner serves as a glitch filter for the GPO.

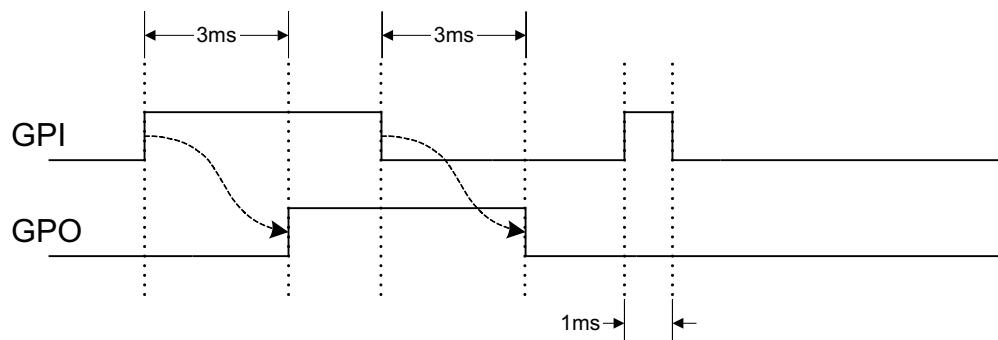

**Figure 18. GPO Behavior When Not Ignoring Inputs During Delay**

The *Ignore Input During Delay* bit allows to output a change in GPO even if it occurs for a time shorter than the delay. This configuration setting has the GPO ignore any activity from the triggering event until the delay expires. [Figure 19](#) represents the two cases for when ignoring the inputs during a delay. In the case in which the logic changes occur with more time than the delay, the GPO signal looks the same as if the input was not ignored. Then on a GPI pulse shorter than the delay the GPO still changes state. Any pulse that occurs on the GPO when having the *Ignore Input During Delay* bit set will have a width of at least the time delay.

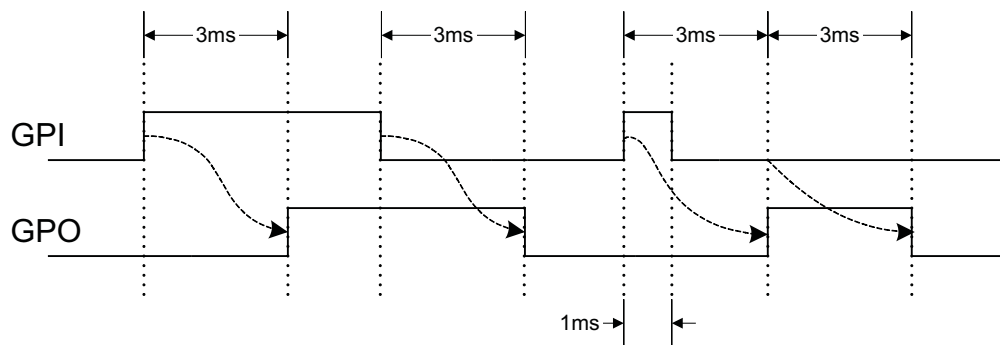

**Figure 19. GPO Behavior When Ignoring Inputs During Delay**

### State Machine Mode Enable

When this bit within the GPO\_CONFIG command is set, only one of the AND path will be used at a given time. When the GPO logic result is currently TRUE, AND path 0 will be used until the result becomes FALSE. When the GPO logic result is currently FALSE, AND path 1 will be used until the result becomes TRUE. This provides a very simple state machine and allows for more complex logical combinations.

### GPI Special Functions

There are five special input functions for which GPIs can be used. There can be no more than one pin assigned to each of these functions.

- **GPI Fault Enable** - When set, the de-assertion of the GPI is treated as a fault.
- **Latched Statuses Clear Source** - When a GPO uses a latched status type (`_LATCH`), you can configure a GPI that will clear the latched status.
- **Input Source for Margin Enable** - When this pin is asserted, all rails with margining enabled will be put in a margined state (low or high).
- **Input Source for Margin Low/Not-High** - When this pin is asserted all margined rails will be set to Margin Low as long as the Margin Enable is asserted. When this pin is de-asserted the rails will be set to Margin High.
- **Fans Installed** - Fan control is enabled while this pin is asserted.

The polarity of GPI pins can be configured to be either Active Low or Active High. The first 3 GPIs that are defined regardless of their main purpose will be used for the `PIN_SELECTED_RAIL_STATES` command.

### Power-Supply Enables

Each GPIO can be configured as a rail-enable pin with either active-low or active-high polarity. Output mode options include open-drain or push-pull outputs that can be actively driven to 3.3 V or ground. During reset, the GPIO pins are high-impedance except for FPWM/GPIO pins 17–24, which are driven low. External pulldown or pullup resistors can be tied to the enable pins to hold the power supplies off during reset. The UCD90124A can support a maximum of 12 reset enable pins.

#### NOTE

GPIO pins that have FPWM capability (pins 17-24) should only be used as power-supply enable signals if the signal is active high.

### Cascading Multiple Devices

A GPIO pin can be used to coordinate multiple controllers by using it as a power good-output from one device and connecting it to the `PMBUS_CNTRL` input pin of another. This imposes a master/slave relationship among multiple devices. During startup, the slave controllers initiate their start sequences after the master has completed its start sequence and all rails have reached regulation voltages. During shutdown, as soon as the master starts to sequence-off, it sends the shut-down signal to its slaves.

A shutdown on one or more of the master rails can initiate shutdowns of the slave devices. The master shutdowns can be initiated intentionally or by a fault condition. This method works to coordinate multiple controllers, but it does not enforce interdependency between rails within a single controller.

The PMBus specification implies that the power-good signal is active when ALL the rails in a controller are regulating at their programmed voltage. The UCD90124A allows GPIOs to be configured to respond to a desired subset of power-good signals.

## PWM Outputs

### FPWM1-8

Pins 17–24 can be configured as fast pulse-width modulators (FPWMs). The frequency range is 15.260 kHz to 125 MHz. FPWMs can be configured as closed-loop margining outputs, fan controllers or general-purpose PWMs.

Any FPWM pin not used as a PWM output can be configured as a GPIO. One FPWM in a pair can be used as a PWM output and the other pin can be used as a GPO. The FPWM pins are actively driven low from reset when used as GPOs.

The frequency settings for the FPWMs apply to pairs of pins:

- FPWM1 and FPWM2 – same frequency
- FPWM3 and FPWM4 – same frequency
- FPWM5 and FPWM6 – same frequency
- FPWM7 and FPWM8 – same frequency

If an FPWM pin from a pair is not used while its companion is set up to function as a PWM, it is recommended to configure the unused FPWM pin as an active-low open-drain GPO so that it does not disturb the rest of the system. By setting an FPWM, it automatically enables the other FPWM within the pair if it was not configured for any other functionality.

The frequency for the FPWM is derived by dividing down a 250MHz clock. To determine the actual frequency to which an FPWM can be set, must divide 250MHz by any integer between 2 and  $(2^{14}-1)$ .

The FPWM duty cycle resolution is dependent on the frequency set for a given FPWM. Once the frequency is known the duty cycle resolution can be calculated as [Equation 1](#).

$$\text{Change per Step } (\%)_{\text{FPWM}} = \text{frequency} \div (250 \times 10^6 \times 16) \quad (1)$$

Take for an example determining the actual frequency and the duty cycle resolution for a 75MHz target frequency.

1. Divide 250MHz by 75MHz to obtain 3.33.
2. Round off 3.33 to obtain an integer of 3.
3. Divide 250MHz by 3 to obtain actual closest frequency of 83.333MHz.
4. Use [Equation 1](#) to determine duty cycle resolution to obtain 2.0833% duty cycle resolution.

### PWM1-4

Pins 31, 32, 41, and 42 can be used as GPIOs or PWM outputs.

If configured as PWM outputs, then limitations apply:

- PWM1 has a fixed frequency of 10 kHz
- PWM2 has a fixed frequency of 1 kHz
- PWM3 and PWM4 frequencies can be 0.93 Hz to 7.8125 MHz.

The frequency for PWM3 and PWM4 is derived by dividing down a 15.625MHz clock. To determine the actual frequency to which these PWMs can be set, must divide 15.625MHz by any integer between 2 and  $(2^{24}-1)$ . The duty cycle resolution will be dependent on the set frequency for PWM3 and PWM4.

The PWM3 or PWM4 duty cycle resolution is dependent on the frequency set for the given PWM. Once the frequency is known the duty cycle resolution can be calculated as [Equation 2](#)

$$\text{Change per Step } (\%)_{\text{PWM3/4}} = \text{frequency} \div 15.625 \times 10^6 \quad (2)$$

To determine the closest frequency to 1MHz that PWM3 can be set to calculate as the following:

1. Divide 15.625MHz by 1MHz to obtain 15.625.
2. Round off 15.625 to obtain an integer of 16.
3. Divide 15.625MHz by 16 to obtain actual closest frequency of 976.563kHz.
4. Use [Equation 2](#) to determine duty cycle resolution to obtain 6.25% duty cycle resolution.

All frequencies below 238Hz will have a duty cycle resolution of 0.0015%.

### Programmable Multiphase PWMs

The FPWMs can be aligned with reference to their phase. The phase for each FPWM is configurable from 0° to 360°. This provides flexibility in PWM-based applications such as power-supply controller, digital clock generation, and others. See an example of four FPWMs programmed to have phases at 0°, 90°, 180° and 270° ([Figure 20](#)).

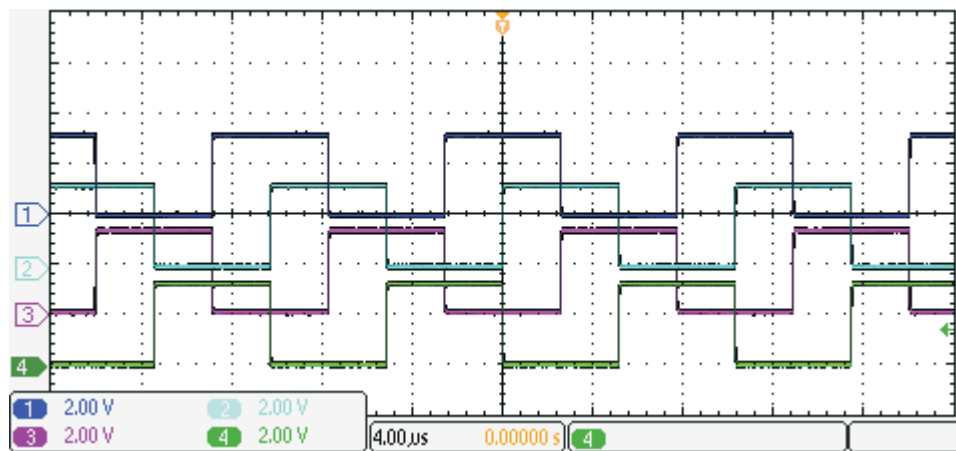

**Figure 20. Multiphase PWMs**

### MARGINING

Margining is used in product validation testing to verify that the complete system works properly over all conditions, including minimum and maximum power-supply voltages, load range, ambient temperature range, and other relevant parameter variations. Margining can be controlled over PMBus using the OPERATION command or by configuring two GPIO pins as margin-EN and margin-UP/DOWN inputs. The MARGIN\_CONFIG command in the *UCD90xxx Sequencer and System Health Controller PMBus Command Reference* describes different available margining options, including ignoring faults while margining and using closed-loop margining to trim the power-supply output voltage one time at power up.

#### Open-Loop Margining

Open-loop margining is done by connecting a power-supply feedback node to ground through one resistor and to the margined power supply output ( $V_{OUT}$ ) through another resistor. The power-supply regulation loop responds to the change in feedback node voltage by increasing or decreasing the power-supply output voltage to return the feedback voltage to the original value. The voltage change is determined by the fixed resistor values and the voltage at  $V_{OUT}$  and ground. Two GPIO pins must be configured as open-drain outputs for connecting resistors from the feedback node of each power supply to  $V_{OUT}$  or ground.

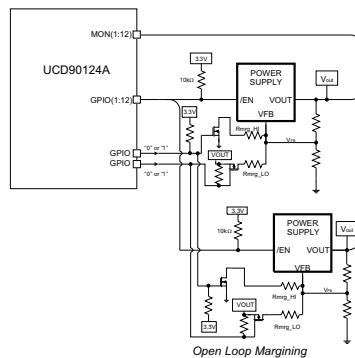

Figure 21. Open-Loop Margining

### Closed-Loop Margining

Closed-loop margining uses a PWM or FPWM output for each power supply that is being margined. An external RC network converts the FPWM pulse train into a DC margining voltage. The margining voltage is connected to the appropriate power-supply feedback node through a resistor. The power-supply output voltage is monitored, and the margining voltage is controlled by adjusting the PWM duty cycle until the power-supply output voltage reaches the margin-low and margin-high voltages set by the user. The voltage setting resolutions will be the same that applies to the voltage measurement resolution (Table 3). The closed loop margining can operate in several modes (Table 6). Given that this closed-loop system has feed back through the ADC, the closed-loop margining accuracy will be dominated by the ADC measurement. The relationship between duty cycle and margined voltage is configurable so that voltage increases when duty cycle increases or decreases. For more details on configuring the UCD90124A for margining, see the *Voltage Margining Using the UCD9012x* application note (SLVA375).

Table 6. Closed Loop Margining Modes

Mode	Description
DISABLE	Margining is disabled.
ENABLE_TRI_STATE	When not margining, the PWM pin is set to high impedance state.
ENABLE_ACTIVE_TRIM	When not margining, the PWM duty-cycle is continuously adjusted to keep the voltage at VOUT_COMMAND.
ENABLE_FIXED_DUTY_CYCLE	When not margining, the PWM duty-cycle is set to a fixed duty-cycle.

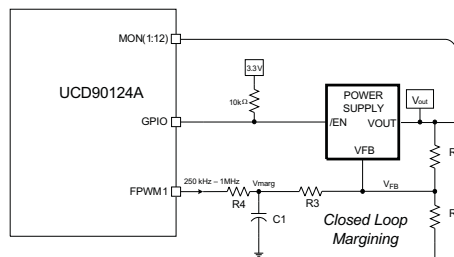

Figure 22. Closed-Loop Margining

### FAN CONTROL

The UCD90124A can control and monitor up to four two-, three- or four-wire fans. Up to four GPIO pins can be used as tachometer inputs. The number of fan tach pulses per revolution for each fan can be entered using the Fusion GUI. A fan speed-fault threshold can be set to trigger an alarm if the measured speed drops below a user-defined value.

The two- and three-wire fans are controlled by connecting the positive input of the fan to the specified supply

# UCD90124A

SLVSN8 – JANUARY 2012

www.ti.com

voltage for the fan. The negative input of the fan is connected to the collector or drain of a transistor. The transistor is turned off and on using a GPIO pin. Four-wire fans can be controlled the same way. However, four-wire fans should use the fan PWM input (the fourth wire). It can be driven directly by one of the eight FPWM or the two adjustable PWM outputs. The normal frequency range for the PWM input is 15 kHz to 40 kHz, but the specifications for the fan confirm the interface procedure.

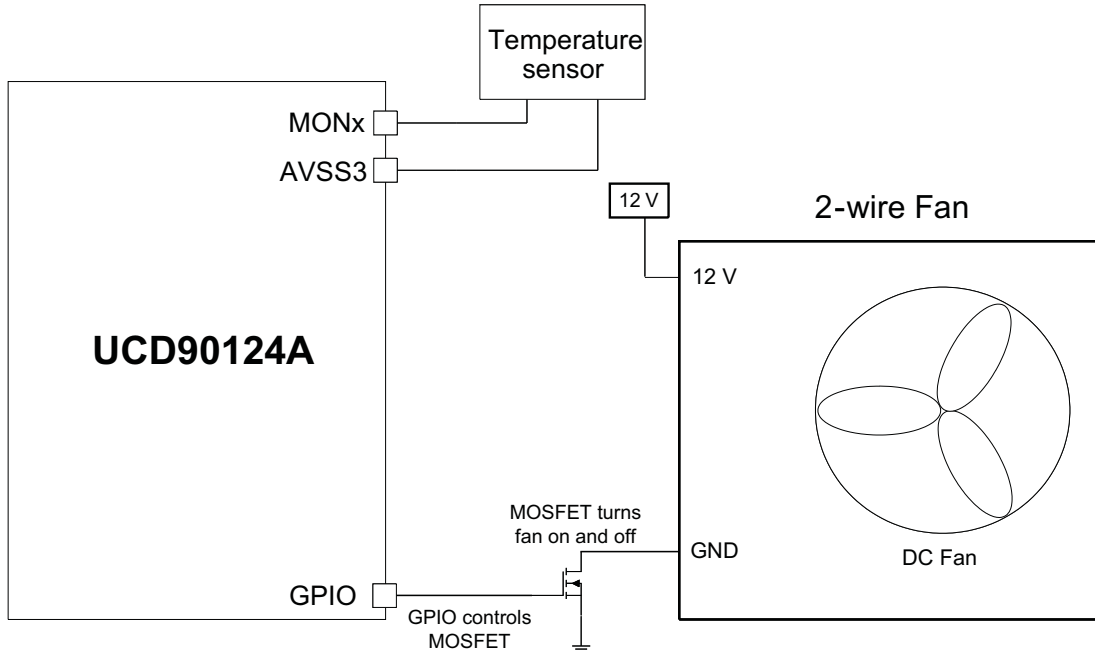

**Figure 23. Two-Wire Fan Connection**

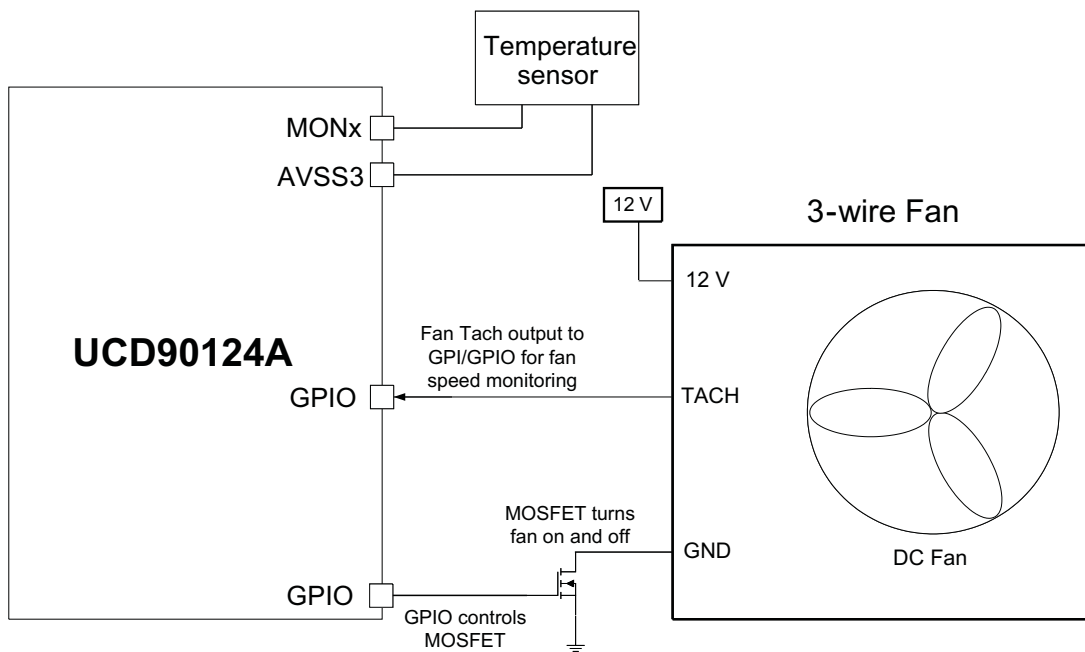

**Figure 24. Three-Wire Fan Connection**

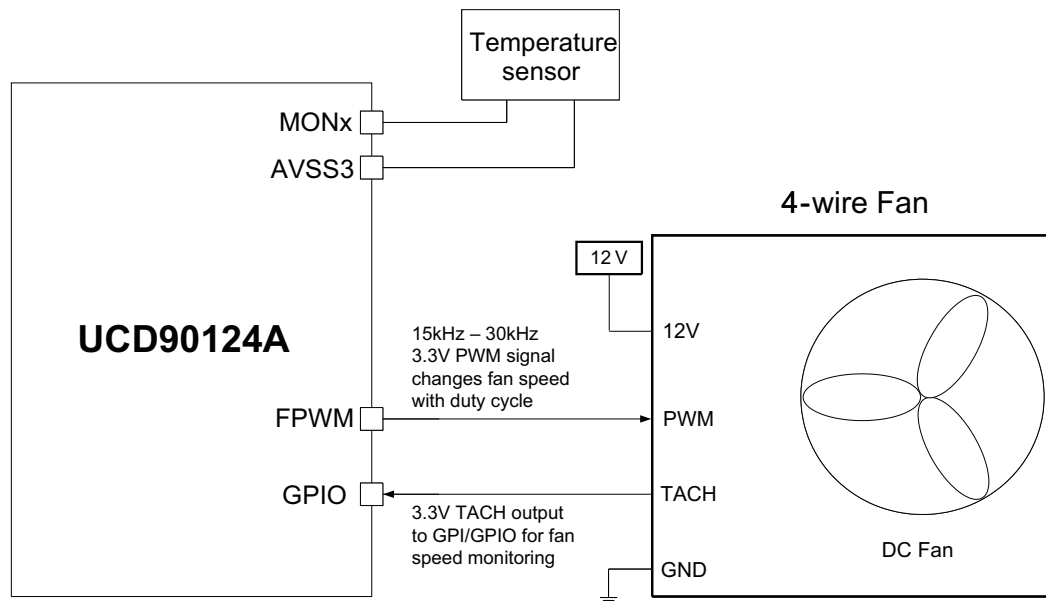

Figure 25. Four-Wire Fan Connection

The UCD90124A autocalibrate feature automatically finds and records the turn-on, turn-off and maximum speeds and duty cycles for any fan. Fans have a minimum speed at which they turn on, a turn-off speed that is usually slightly lower than the turn-on speed, and a maximum speed that occurs at slightly less than 100% duty cycle. Each speed has a PWM duty cycle that goes with it. Every fan is slightly different, even if the model numbers are the same. The built-in temperature control algorithms use the actual measured operating speed range instead of 0 RPM to rated speed of the fan to improve the fan control algorithms. The user can choose whether to use autocalibrate or to manually enter the fan data.

The UCD90124A can control up to four independent fans as defined in the PMBus standard. When enabled, the FAN-PWM control output provides a digital signal with a configurable frequency and duty cycle, with a duty cycle that is set based on the FAN\_COMMAND\_1 PMBus command. The PWM can be set to frequencies between 1 Hz and 125 MHz based on the UCD90124A PWM type selected for the fan control. The duty cycle can be set from 0% to 100% with 1% resolution. The FAN-TACH fan-control input counts the number of transitions in the tachometer output from the fan in each 1-second interval. The tachometer can be read by issuing the READ\_FAN\_SPEED\_1 command. The speed is returned in RPMs.

Fault limits can also be set for the tachometer speed by issuing the FAN\_SPEED\_FAULT\_LIMIT command and the status checked by issuing the STATUS\_FAN\_1\_2 command. See the *UCD90xxx Sequencer and System Health Controller PMBus Command Reference* for a complete description of each command.

The UCD90124A also supports two fan control algorithms.

### Hysteretic Fan Control

Temp<sub>ON</sub> and Temp<sub>OFF</sub> levels are input by the user. Temp<sub>ON</sub> is higher than Temp<sub>OFF</sub>. A GPIO pin is used to turn the fan or fans on at full speed when the monitored temperature reaches Temp<sub>ON</sub> and to turn the fans off when the temperature drops below Temp<sub>OFF</sub>.

Inputs:  $T_{ON}$ ,  $T_{OFF}$ ,  $T_{OT}$ , Update Interval, Rail where MEAS\_TEMP is monitored, GPOx pin

- System starts up at  $t = 0$  seconds
- MEAS\_TEMP = 25°C → ambient temp
- GPO/PWM is low and Fan is off
- Check MEAS\_TEMP every 1 second (or 250 msec)
- When MEAS\_TEMP =  $T_{ON}$ , set GPO/PWM = 1 → turn fan on
- Leave GPO/PWM = 1 unless MEAS\_TEMP <  $T_{OFF}$
- If MEAS\_TEMP is >  $T_{ON}$ , declare a fault and take the prescribed action.

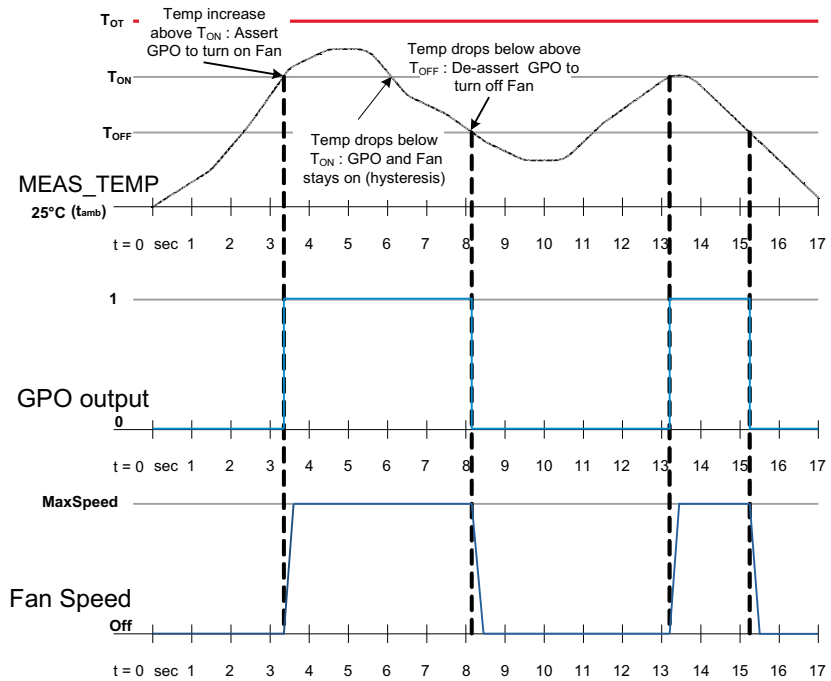

Figure 26. Hysteretic Temperature Control for 2- or 3-wire Fans

### Set Point Fan Control

The second algorithm (Figure 27) uses five control set points that each have a temperature and a fan speed. When the monitored temperature increases above one of the set point temperatures, the fan speed is increased to the corresponding set point value. When the monitored temperature drops below a set point temperature, the fan speed is reduced to the corresponding set point value. The ramp rate for speed can be selected, allowing the user to optimize fan performance and minimize audible noise.

The fan speed is varied by changing the duty cycle of a PWM output. For two- and three-wire fans, as the fan is turned on and off, the inertia of the fan smoothes out the fan speed changes, resulting in variable speed operation. This approach can be taken with any fan, but would most likely be used with two- or three-wire fans at a PWM frequency in the 40-Hz to 80-Hz range. Four-wire fans would use the PWM input as described earlier in this section.

Inputs:  $T_{OT}$ , Updates Interval, Rail that MEAS\_TEMP is being monitored on, PWM pin, PWM freq, PWM temp rate, FANTAC pin, 5x (TEMPn, SPEEDn) setpoints.

- System starts up at  $t = 0$  seconds
- MEAS\_TEMP = 25°C at ambient temp
- PWM DUTY\_CYCLE = 0% and fan is off
- Check MEAS\_TEMP every 250 ms (or 1 s)
- When MEAS\_TEMP > TEMP1:
  - set SPEED\_TARGET = SPEED1
  - increase DUTY\_CYCLE to DUTY\_CYCLE\_ON
  - increase DUTY\_CYCLE by ramp rate (10%/second) until SPEED = SPEED\_TARGET
- When MEAS\_TEMP > TEMP2:
  - set SPEED\_TARGET = SPEED2
  - increase DUTY\_CYCLE by ramp rate until SPEED = SPEED\_TARGET
- Repeat as temperature is increased for each new setpoint
- If MEAS\_TEMP >  $T_{OT}$ , declare a fault and take the prescribed action
- If temperature drops - above TEMP4 to below TEMP3 for example
  - when MEAS\_TEMP drops below TEMP4, maintain SPEED4 → do not change the DUTY\_CYCLE
  - when MEAS\_TEMP drops below TEMP3, set SPEED\_TARGET = SPEED3
  - decrease DUTY\_CYCLE by ramp rate (10%/second) until SPEED = SPEED\_TARGET
- To turn the fan off when MEAS\_TEMP < TEMP1, set SPEED1 = 0 RPM

EXAMPLE: MEAS\_TEMP = 25°C at ambient temp:

- $t = 0$  to 5 sec: MEAS\_TEMP increases from ambient to TEMP1 → increases SPEED\_TARGET from SPD0 (Off) to SPD1 → increases DUTY\_CYCLE from 0% to DUTYON (30%) → ACTUAL fan speed ramps up from 0 RPM to SPD1.
- $t = 5$  to 10 sec: MEAS\_TEMP increases > TEMP2 → increases SPEED\_TARGET from SPD1 to SPD2 → increases DUTY\_CYCLE → ACTUAL fan speed ramps up from SPD1 to SPD2.
- $t = 10$  to 25 sec: MEAS\_TEMP increases to > TEMP5 → SPEED\_TARGET increases from SPD2 to SPD5 → DUTY\_CYCLE ramps to DUTYMAX → ACTUAL fan speed increases SPD5.
- $t = 25$  to 30 sec: MEAS\_TEMP stays > TEMP5 → SPEED\_TARGET and DUTY\_CYCLE do not change → ACTUAL fan speed stays at SPD5.
- $t = 30$  to 35 sec: MEAS\_TEMP decreases to < TEMP4 → SPEED\_TARGET drops to SPD4 and then to SPD3 → decreases DUTY\_CYCLE → ACTUAL fan speed ramps down from SPD5 to SPD3.
- $t = 35$  to 60 sec: MEAS\_TEMP decreases to < TEMP1 → SPEED\_TARGET drops to SPD0 → decreases DUTY\_CYCLE to DUTYOFF → ACTUAL fan speed ramps down from SPD3 to SPD0 (Off).

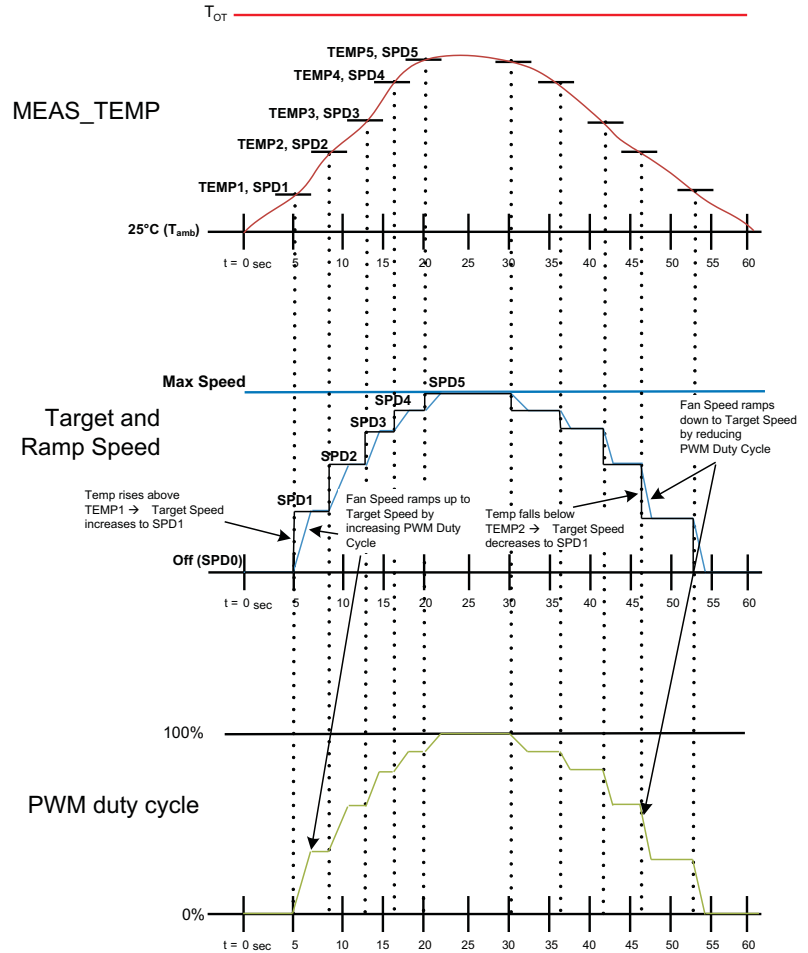

Figure 27. Temperature and Speed Set Point PWM Control for Four-Wire Fans

### SYSTEM RESET SIGNAL

The UCD90124A can generate a programmable system-reset pulse as part of sequence-on. The pulse is created by programming a GPIO to remain deasserted until the voltage of a particular rail or combination of rails reach their respective POWER\_GOOD\_ON levels plus a programmable delay time. The system-reset delay duration can be programmed as shown in Table 7. See an example of two SYSTEM RESET signals Figure 28. The first SYSTEM RESET signal is configured so that it de-asserts on Power Good On and it asserts on Power Good Off after a given common delay time. The second SYSTEM RESET signal is configured so that it sends a pulse after a delay time once Power Good On is achieved. The pulse width can be configured between 0.001s to 32.256s. See the *UCD90xxx Sequencer and System Health Controller PMBus Command Reference* for pulse width configuration details.

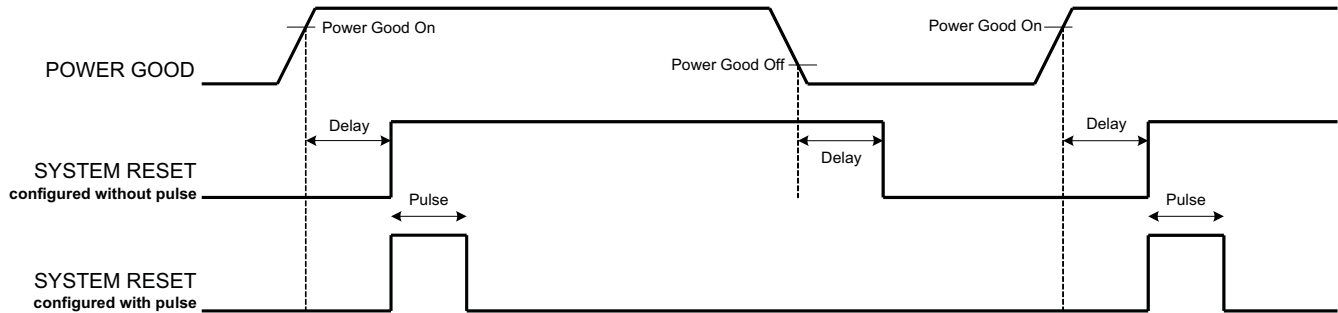

Figure 28. System Reset with and without Pulse Setting

The system reset can react to watchdog timing. In Figure 29 The first delay on SYSTEM RESET is for the initial reset release that would get a CPU running once all necessary voltage rails are in regulation. The watchdog is configured with a Start Time and a Reset Time. If these times expire without the WDI clearing them then it is expected that the CPU providing the watchdog signal is not operating. The SYSTEM RESET is toggled either using a Delay or GPI Tracking Release Delay to see if the CPU recovers.

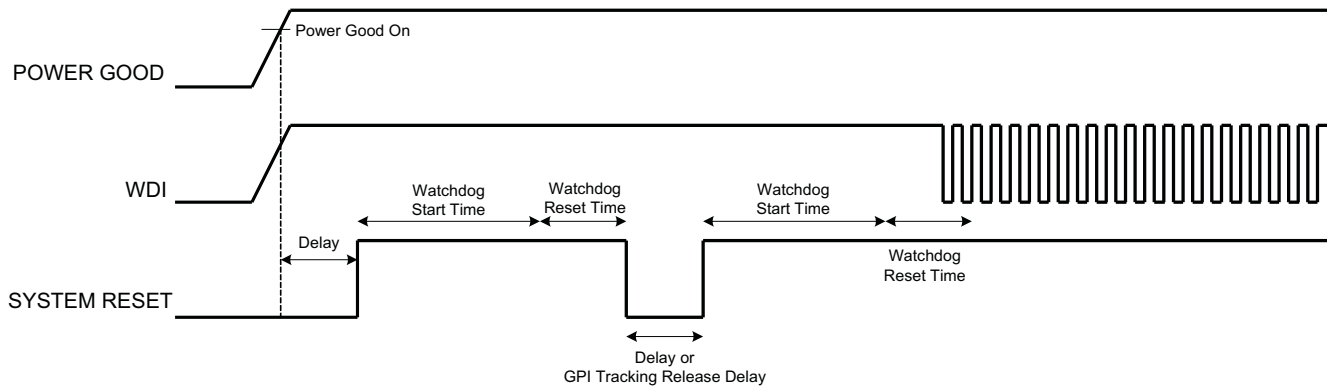

Figure 29. System Reset with Watchdog

Table 7. System-Reset Delay

Delay
0 ms
1 ms
2 ms
4 ms
8 ms
16 ms
32 ms

**Table 7. System-Reset Delay (continued)**

Delay
64 ms
128 ms
256 ms
512 ms
1.02 s
2.05 s
4.10 s
8.19 s
16.38 s
32.8 s

## WATCH DOG TIMER

A GPI and GPO can be configured as a watchdog timer (WDT). The WDT can be independent of power-supply sequencing or tied to a GPIO functioning as a watchdog output (WDO) that is configured to provide a system-reset signal. The WDT can be reset by toggling a watchdog input (WDI) pin or by writing to SYSTEM\_WATCHDOG\_RESET over I<sup>2</sup>C. The WDI and WDO pins are optional when using the watchdog timer. The WDI can be replaced by SYSTEM\_WATCHDOG\_RESET command and the WDO can be manifested through the Boolean Logic defined GPOs or through the System Reset function.

The WDT can be active immediately at power up or set to wait while the system initializes. [Table 8](#) lists the programmable wait times before the initial timeout sequence begins.

**Table 8. WDT Initial Wait Time**

WDT INITIAL WAIT TIME
0 ms
100 ms
200 ms
400 ms
800 ms
1.6 s
3.2 s
6.4 s
12.8 s
25.6 s
51.2 s
102 s
205 s
410 s
819 s
1638 s

The watchdog timeout is programmable from 0.001s to 32.256s. See the *UCD90xxx Sequencer and System Health Controller PMBus Command Reference* for details on configuring the watchdog timeout. If the WDT times out, the UCD90124A can assert a GPIO pin configured as WDO that is separate from a GPIO defined as system-reset pin, or it can generate a system-reset pulse. After a timeout, the WDT is restarted by toggling the WDI pin or by writing to SYSTEM\_WATCHDOG\_RESET over I<sup>2</sup>C.

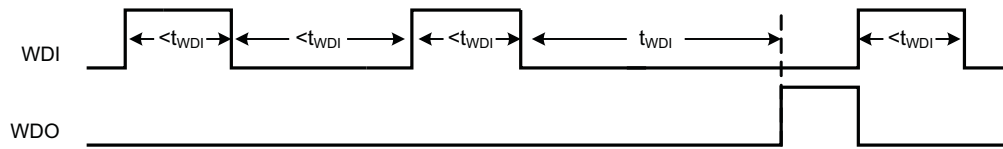

**Figure 30. Timing of GPIOs Configured for Watchdog Timer Operation**

## DATA AND ERROR LOGGING TO FLASH MEMORY

The UCD90124A can log faults and the number of device resets to flash memory. Peak voltage measurements are also stored for each rail. To reduce stress on the flash memory, a 30-second timer is started if a measured value exceeds the previously logged value. Only the highest value from the 30-second interval is written from RAM to flash.

Multiple faults can be stored in flash memory and can be accessed over PMBus to help debug power-supply bugs or failures. Each logged fault includes:

- Rail number
- Fault type
- Fault time since previous device reset
- Last measured rail voltage

The total number of device resets is also stored to flash memory. The value can be reset using PMBus.

With the brownout function enabled, the run-time clock value, peak monitor values, and faults are only logged to flash when a power-down is detected. The device run-time clock value is stored across resets or power cycles unless the brownout function is disabled, in which case the run-time clock is returned to zero after each reset.

It is also possible to update and calibrate the UCD90124A internal run-time clock via a PMBus host. For example, a host processor with a real-time clock could periodically update the UCD90124A run-time clock to a value that corresponds to the actual date and time. The host must translate the UCD90124A timer value back into the appropriate units, based on the usage scenario chosen. See the `REAL_TIME_CLOCK` command in the *UCD90xxx Sequencer and System Health Controller PMBus Command Reference* for more details.

## BROWNOUT FUNCTION

The UCD90124A can be enabled to turn off all nonvolatile logging until a brownout event is detected. A brownout event occurs if  $V_{CC}$  drops below 2.9 V. In order to enable this feature, the user must provide enough local capacitance to deliver up to 80 mA (consider additional load based on GPOs sourcing external circuits such as LEDs) on for 5 ms while maintaining a minimum of 2.6 V at the device. If using the brownout circuit ([Figure 31](#)), then a schottky diode should be placed so that it blocks the other circuits that are also powered from the 3.3V supply.

With this feature enabled, the UCD90124A saves faults, peaks, and other log data to SRAM during normal operation of the device. Once a brownout event is detected, all data is copied from SRAM to Flash. Use of this feature allows the UCD90124A to keep track of a single run-time clock that spans device resets or system power down (rather than resetting the run time clock after device reset). It can also improve the UCD90124A internal response time to events, because Flash writes are disabled during normal system operation. This is an optional feature and can be enabled using the `MISC_CONFIG` command. For more details, see the *UCD90xxx Sequencer and System Health Controller PMBus Command Reference*.

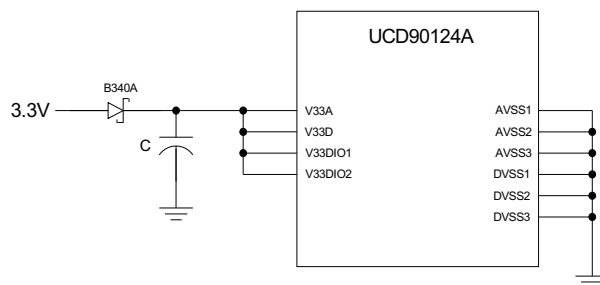

Figure 31. Brownout Circuit

## PMBUS ADDRESS SELECTION

Two pins are allocated to decode the PMBus address. At power up, the device applies a bias current to each address-detect pin, and the voltage on that pin is captured by the internal 12-bit ADC. The PMBus address is calculated as follows.

$$\text{PMBus Address} = 12 \times \text{bin}(V_{AD01}) + \text{bin}(V_{AD00})$$

Where  $\text{bin}(V_{AD0x})$  is the address bin for one of eight addresses as shown in Table 9. The address bins are defined by the MIN and MAX VOLTAGE RANGE (V). Each bin is a constant ratio of 1.25 from the previous bin. This method maintains the width of each bin relative to the tolerance of standard 1% resistors.

Table 9. PMBus Address Bins

ADDRESS BIN	RPMBus PMBus RESISTANCE (kΩ)
open	—
11	200
10	154
9	118
8	90.9
7	69.8
6	53.6
5	41.2
4	31.6
short	—

A low impedance (short) on either address pin that produces a voltage below the minimum voltage causes the PMBus address to default to address 126 (0x7E). A high impedance (open) on either address pin that produces a voltage above the maximum voltage also causes the PMBus address to default to address 126 (0x7E).

Address 0 is not used because it is the PMBus general-call address. Addresses 11 and 127 can not be used by this device or any other device that shares the PMBus with it, because those are reserved for manufacturing programming and test. It is recommended that address 126 not be used for any devices on the PMBus, because this is the address that the UCD90124A defaults to if the address lines are shorted to ground or left open. Table 10 summarizes which PMBus addresses can be used. Other SMBus/PMBus addresses have been assigned for specific devices. For a system with other types of devices connected to the same PMBus, see the SMBus device address assignments table in Appendix C of the latest version of the System Management Bus (SMBus) specification. The SMBus specification can be downloaded at <http://smbus.org/specs/smbus20.pdf>.

Table 10. PMBus Address Assignment Rules

Address	STATUS	Reason
0	Prohibited	SMBus generaladdress call
1-10	Available	

**Table 10. PMBus Address Assignment Rules (continued)**

Address	STATUS	Reason
11	Avoid	Causes conflicts with other devices during program flash updates.
12	Prohibited	PMBus alert response protocol
13-125	Available	
126	For JTAG Use	Default value; may cause conflicts with other devices.
127	Prohibited	Used by TI manufacturing for device tests.

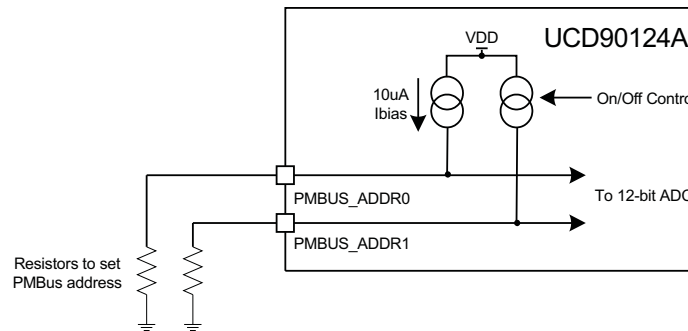

**Figure 32. PMBus Address-Detection Method**

**CAUTION**

Leaving the address in default state as 126 (0x7E) will enable the JTAG and not allow using the JTAG compatible pins (36-39) as GPIOs.

**DEVICE RESET**

The UCD90124A has an integrated power-on reset (POR) circuit which monitors the supply voltage. At power up, the POR detects the  $V_{33D}$  rise. When  $V_{33D}$  is greater than  $V_{RESET}$ , the device comes out of reset.

The device can be forced into the reset state by an external circuit connected to the  $\overline{RESET}$  pin. A logic-low voltage on this pin for longer than  $t_{RESET}$  holds the device in reset. It comes out of reset within 1 ms after  $\overline{RESET}$  is released and can return to a logic-high level. To avoid an erroneous trigger caused by noise, a pullup resistor to 3.3 V is recommended.

Any time the device comes out of reset, it begins an initialization routine which lasts approximately 20 ms. During the initialization routine, the FPWM pins are held low, and all other GPIO and GPI pins are open-circuit. At the end of the initialization routine, the device begins normal operation as defined by the device configuration.

**DEVICE CONFIGURATION AND PROGRAMMING**

From the factory, the device contains the sequencing and monitoring firmware. It is also configured so that all GPOs are high-impedance (except for FPWM/GPIO pins 17-24, which are driven low), with no sequencing or fault-response operation. See *Configuration Programming of UCD Devices*, available from the *Documentation & Help Center* that can be selected from the *Fusion GUI* Help menu, for full UCD90124A configuration details.

After the user has designed a configuration file using *Fusion GUI*, there are three general device-configuration programming options:

1. Devices can be programmed in-circuit by a host microcontroller using PMBus commands over I<sup>2</sup>C (see the *UCD90xxx Sequencer and System Health Controller PMBus Command Reference*). Each parameter write replaces the data in the associated memory (RAM) location. After all the required configuration data has been sent to the device, it is transferred to the associated nonvolatile memory (data flash) by issuing a special command, STORE\_DEFAULT\_ALL. This method is how the *Fusion GUI* normally reads and writes a device configuration.
2. The *Fusion GUI* (Figure 33) can create a PMBus or I<sup>2</sup>C command script file that can be used by the I<sup>2</sup>C master to configure the device.

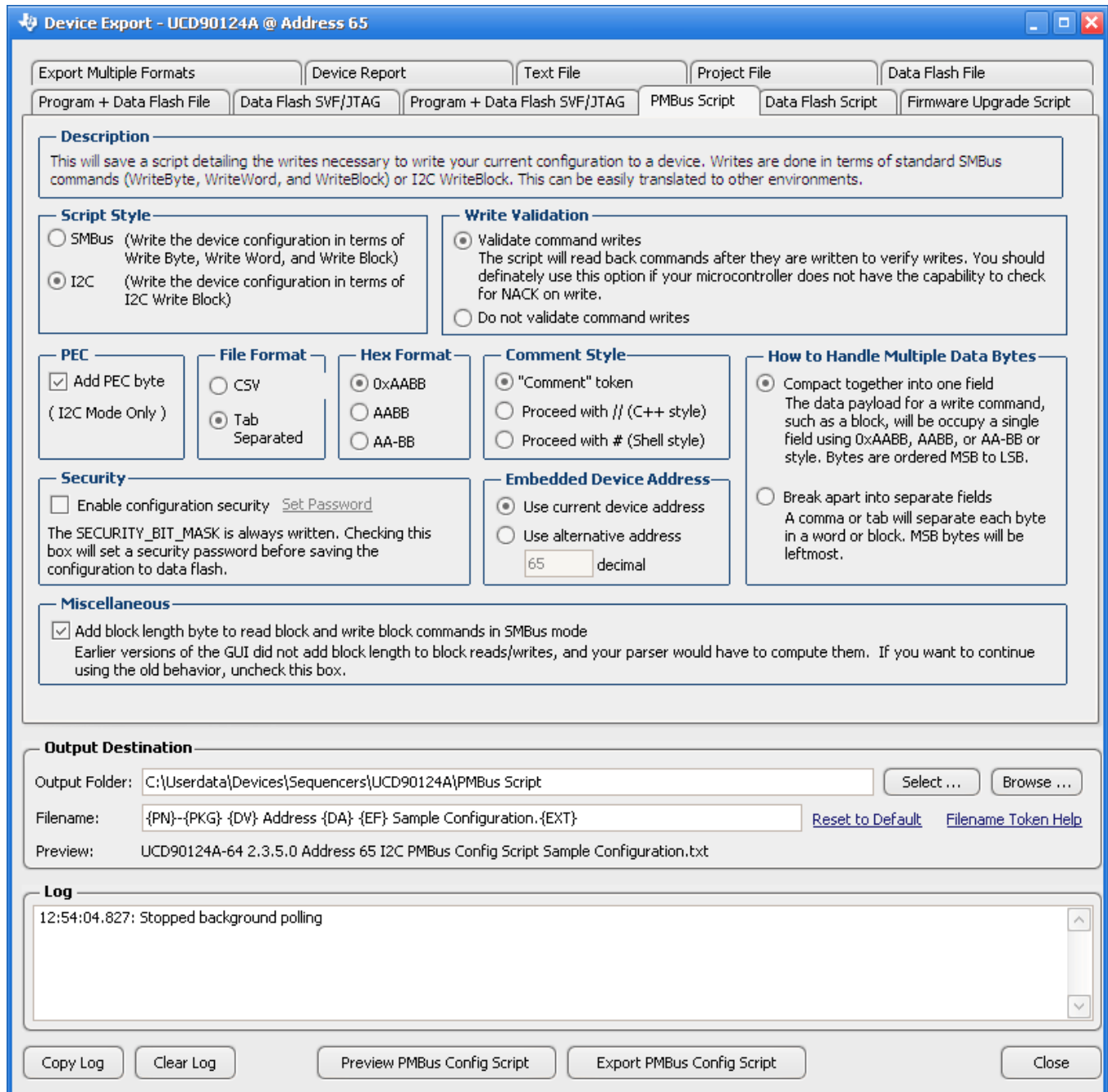
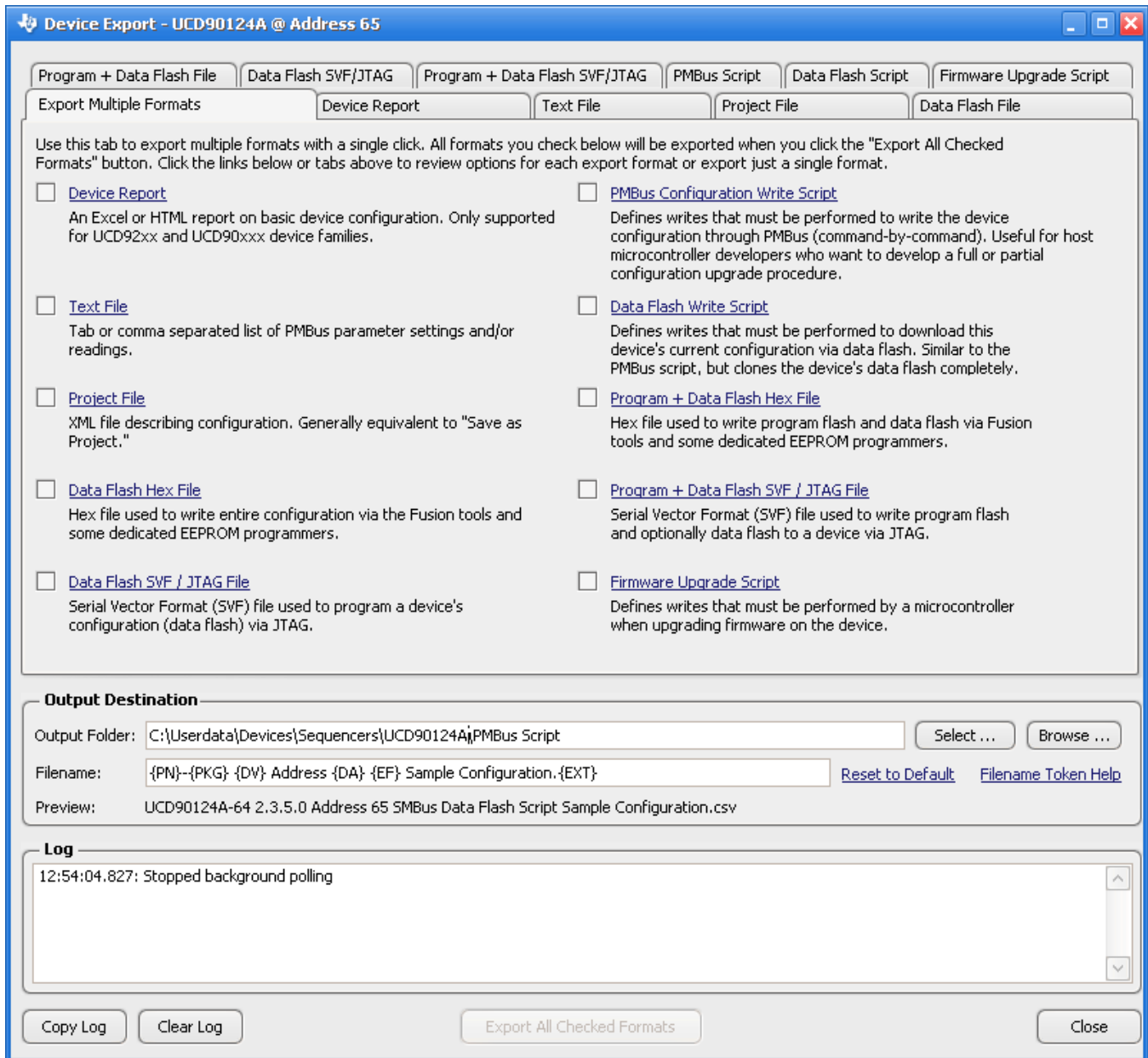

Figure 33. Fusion GUI PMBus Configuration Script Export Tool

- Another in-circuit programming option is for the *Fusion GUI* to create a data flash image from the configuration file (Figure 34). The configuration files can be exported in Intel Hex, Serial Vector Format (SVF) and S-record. The image file can be downloaded into the device using I<sup>2</sup>C or JTAG. The *Fusion GUI* tools can be used on-board if the *Fusion GUI* can gain ownership of the target board I<sup>2</sup>C bus.



**Figure 34. Fusion GUI Device Configuration Export Tool**

Devices can be programmed off-board using the *Fusion GUI* tools or a dedicated device programmer. For small runs, a ZIF socketed board with an I<sup>2</sup>C header can be used with the standard *Fusion GUI* or manufacturing GUI. The TI Evaluation Module for UCD90xxx 64-pin Sequencer and System Health Monitor (UCD90SEQEVM64-650) can be used for this purpose. The *Fusion GUI* can also create a data flash file that can then be loaded into the UCD90124A using a dedicated device programmer.

To configure the device over I<sup>2</sup>C or PMBus, the UCD90124A must be powered. The PMBus clock and data pins must be accessible and must be pulled high to the same V<sub>DD</sub> supply that powers the device, with pullup resistors between 1 kΩ and 2 kΩ. Care should be taken to not introduce additional bus capacitance (<100 pF). The user configuration can be written to data flash using a gang programmer via JTAG or I<sup>2</sup>C before the device is installed in circuit. To use I<sup>2</sup>C, the clock and data lines must be multiplexed or the device addresses must be assigned by socket. The *Fusion GUI* tools can be used for socket addressing. Pre-programming can also be done using a single device test fixture.

**Table 11. Configuration Options**

	Data Flash via JTAG	Data Flash via I <sup>2</sup> C	PMBus Commands via I <sup>2</sup> C
Off-Board Configuration	Data Flash Export (.svf type file)	Data Flash Export (.srec or hex type file)	Project file I <sup>2</sup> C/PMBus script
	Dedicated programmer	Fusion tools (with exclusive bus access via USB to I <sup>2</sup> C adapter)	Fusion tools (with exclusive bus access via USB to I <sup>2</sup> C adapter)
On-Board Configuration	Data flash export	Fusion tools (with exclusive bus access via USB to I <sup>2</sup> C adapter)	Fusion tools (with exclusive bus access via USB to I <sup>2</sup> C adapter)
	IC		

The advantages of off-board configuration include:

- Does not require access to device I<sup>2</sup>C bus on board.
- Once soldered on board, full board power is available without further configuration.
- Can be partially reconfigured once the device is mounted.

### Full Configuration Update while in Normal Mode

Although performing a full configuration of the UCD90124A in a controlled test setup is recommended, there may be times in which it is required to update the configuration while the device is in an operating system. Updating the full configuration based on methods listed in **DEVICE CONFIGURATION AND PROGRAMMING** section while the device is in an operating system can be challenging because these methods do not permit the UCD90124A to operate as required by application during the programming. During described methods the GPIOs may not be in the desired states which can disable rails that provide power to the UCD90124A. To overcome this, the UCD90124A has the capability to allow full configuration update while still operating in normal mode.

Updating the full configuration while in normal mode will consist of disabling data flash write protection, erasing the data flash, writing the data flash image and reset the device. It is not required to reset the device immediately but make note that the UCD90124A will continue to operate based on previous configuration with fault logging disabled until reset. See *Configuration Programming of UCD Devices*, available from the *Documentation & Help Center* that can be selected from the *Fusion GUI* Help menu, for details.

### JTAG INTERFACE

The JTAG port can be used for production programming. Four of the six JTAG pins can also be used as GPIOs during normal operation. See the *Pin Functions* table at the beginning of the document and **Table 4** for a list of the JTAG signals and which can be used as GPIOs. The JTAG port is compatible with the IEEE Standard 1149.1-1990, IEEE Standard Test-Access Port and Boundary Scan Architecture specification. Boundary scan is not supported on this device.

The JTAG interface can provide an alternate interface for programming the device. It is disabled by default in order to enable the GPIO pins with which it is multiplexed. There are two conditions under which the JTAG interface is enabled:

1. On power-up if the data flash is blank, allowing JTAG to be used for writing the configuration parameters to a programmed device with no PMBus interaction
2. When address 126 (0x7E) is detected at power up. A short to ground or an open condition on either address pin will cause an address 126 (0x7E) to be generated which enables JTAG mode.

The UCD90124A system clock runs at 90% of nominal speed while in JTAG mode. For this reason it is important that the UCD90124A is not left in JTAG mode for normal application operation.

The Fusion GUI can create SVF files (See **DEVICE CONFIGURATION AND PROGRAMMING** section) based on a given data flash configuration which can be used to program the desired configuration by JTAG. For Boundary Scan Description Language (BSDL) file that supports the UCD90124A see the product folder in [www.ti.com](http://www.ti.com).

There are many JTAG programmers in the market and they all do not function the same. If you plan to use JTAG to configure the device, confirm that you can reliably configure the device with your JTAG tools before committing to a programming solution.

## INTERNAL FAULT MANAGEMENT AND MEMORY ERROR CORRECTION (ECC)

The UCD90124A verifies the firmware checksum at each power up. If it does not match, then the device waits for I<sup>2</sup>C commands but does not execute the firmware. A device configuration checksum verification is also performed at power up. If it does not match, the factory default configuration is loaded. The PMBALERT# pin is asserted and a flag is set in the status register. The error-log checksum validates the contents of the error log to make sure that section of flash is not corrupted.

There is an internal firmware watchdog timer. If it times out, the device resets so that if the firmware program is corrupted, the device goes back to a known state. This is a normal device reset, so all of the GPIO pins are open-drain and the FPWM pins are driven low while the device is in reset. Checks are also done on each parameter that is passed, to make sure it falls within the acceptable range.

Error-correcting code (ECC) is used to improve data integrity and provide high-reliability storage of Data Flash contents. ECC uses dedicated hardware to generate extra check bits for the user data as it is written into the Flash memory. This adds an additional six bits to each 32-bit memory word stored into the Flash array. These extra check bits, along with the hardware ECC algorithm, allow for any single-bit error to be detected and corrected when the Data Flash is read.

APPLICATION INFORMATION

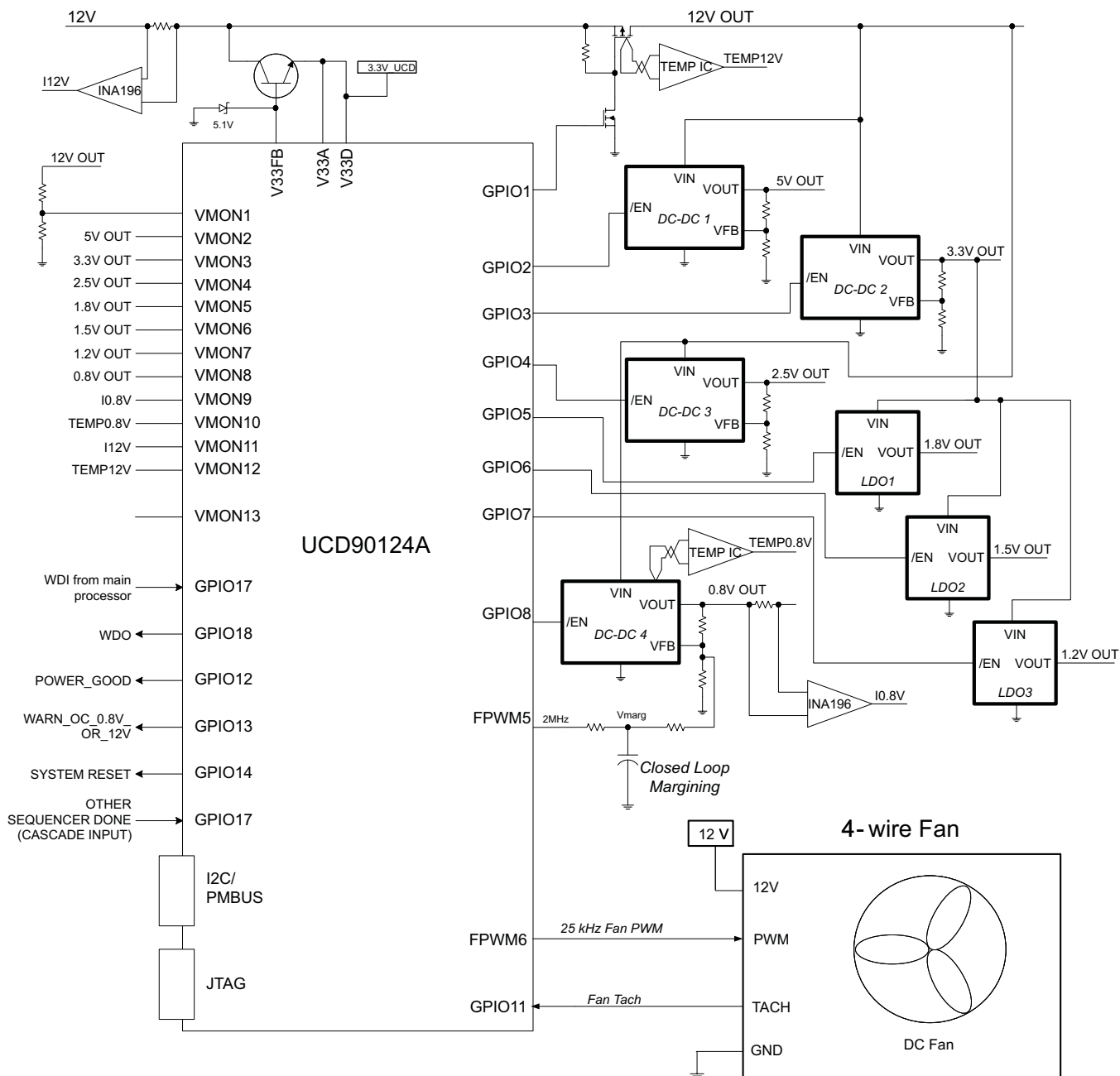

Figure 35. Typical Application Schematic

NOTE

Figure 35 is a simplified application schematic. Voltage dividers such as the ones placed on VMON1 input have been omitted for simplifying the schematic. All VMONx pins which are configured to measure a voltage that exceeds the 2.5V ADC reference are required to have a voltage divider.

### Layout guidelines

The thermal pad provides a thermal and mechanical interface between the device and the printed circuit board (PCB). Connect the exposed thermal pad of the PCB to the device  $V_{SS}$  pins and provide at least a  $4 \times 4$  pattern of PCB vias to connect the thermal pad and  $V_{SS}$  pins to the circuit ground on other PCB layers.

For supply-voltage decoupling, provide power-supply pin bypass to the device as follows:

- 0.1- $\mu$ F, X7R ceramic in parallel with 0.01- $\mu$ F, X7R ceramic at pin 47 (BPCAP)
- 0.1- $\mu$ F, X7R ceramic in parallel with 4.7- $\mu$ F, X5R ceramic at pins 44 ( $V_{33DIO2}$ ) and 45 ( $V_{33D}$ )
- 0.1- $\mu$ F, X7R ceramic at pin 7 ( $V_{33DIO1}$ )
- 0.1- $\mu$ F, X7R ceramic in parallel with 4.7- $\mu$ F, X5R ceramic at pin 46 ( $V_{33A}$ )

Depending on use and application of the various GPIO signals used as digital outputs, some impedance control may be desired to quiet fast signal edges. For example, when using the FPWM pins for fan control or voltage margining, the pin is configured as a digital *clock* signal. Route these signals away from sensitive analog signals. It is also good design practice to provide a series impedance of 20  $\Omega$  to 33  $\Omega$  at the signal source to slow fast digital edges.

### Estimating ADC Reporting Accuracy

The UCD90124A uses a 12-bit ADC and an internal 2.5-V reference ( $V_{REF}$ ) to convert MON pin inputs into digitally reported voltages. The least significant bit (LSB) value is  $V_{LSB} = V_{REF}/2^N$  where  $N = 12$ , resulting in a VLSB = 610  $\mu$ V. The error in the reported voltage is a function of the ADC linearity errors and any variations in  $V_{REF}$ . The total unadjusted error ( $E_{TUE}$ ) for the UCD90124A ADC is  $\pm 5$  LSB, and the variation of  $V_{REF}$  is  $\pm 0.5\%$  between  $0^\circ\text{C}$  and  $125^\circ\text{C}$  and  $\pm 1\%$  between  $-40^\circ\text{C}$  and  $125^\circ\text{C}$ .  $V_{TUE}$  is calculated as  $V_{LSB} \times E_{TUE}$ . The total reported voltage error is the sum of the reference-voltage error and  $V_{TUE}$ . At lower monitored voltages,  $V_{TUE}$  dominates reported error, whereas at higher monitored voltages, the tolerance of  $V_{REF}$  dominates the reported error. Reported error can be calculated using [Equation 3](#), where REFTOL is the tolerance of  $V_{REF}$ ,  $V_{ACT}$  is the actual voltage being monitored at the MON pin, and  $V_{REF}$  is the nominal voltage of the ADC reference.

$$RPT_{ERR} = \left( \frac{1 + REFTOL}{V_{ACT}} \right) \times \left( \frac{V_{REF} \times E_{TUE}}{4096} + V_{ACT} \right) - 1 \quad (3)$$

From [Equation 3](#), for temperatures between  $0^\circ\text{C}$  and  $125^\circ\text{C}$ , if  $V_{ACT} = 0.5$  V, then  $RPT_{ERR} = 1.11\%$ . If  $V_{ACT} = 2.2$  V, then  $RPT_{ERR} = 0.64\%$ . For the full operating temperature range of  $-40^\circ\text{C}$  to  $125^\circ\text{C}$ , if  $V_{ACT} = 0.5$  V, then  $RPT_{ERR} = 1.62\%$ . If  $V_{ACT} = 2.2$  V, then  $RPT_{ERR} = 1.14\%$ .

**PACKAGING INFORMATION**

Orderable Device	Status (1)	Package Type	Package Drawing	Pins	Package Qty	Eco Plan (2)	Lead/Ball Finish	MSL Peak Temp (3)	Op Temp (°C)	Top-Side Markings (4)	Samples
UCD90124ARGCR	ACTIVE	VQFN	RGC	64	2000	Green (RoHS & no Sb/Br)	CU NIPDAU	Level-3-260C-168 HR	-40 to 125	UCD90124A	<a href="#">Samples</a>
UCD90124ARGCT	ACTIVE	VQFN	RGC	64	250	Green (RoHS & no Sb/Br)	CU NIPDAU	Level-3-260C-168 HR	-40 to 125	UCD90124A	<a href="#">Samples</a>

(1) The marketing status values are defined as follows:

**ACTIVE:** Product device recommended for new designs.

**LIFEBUY:** TI has announced that the device will be discontinued, and a lifetime-buy period is in effect.

**NRND:** Not recommended for new designs. Device is in production to support existing customers, but TI does not recommend using this part in a new design.

**PREVIEW:** Device has been announced but is not in production. Samples may or may not be available.

**OBSOLETE:** TI has discontinued the production of the device.

(2) Eco Plan - The planned eco-friendly classification: Pb-Free (RoHS), Pb-Free (RoHS Exempt), or Green (RoHS & no Sb/Br) - please check <http://www.ti.com/productcontent> for the latest availability information and additional product content details.

**TBD:** The Pb-Free/Green conversion plan has not been defined.

**Pb-Free (RoHS):** TI's terms "Lead-Free" or "Pb-Free" mean semiconductor products that are compatible with the current RoHS requirements for all 6 substances, including the requirement that lead not exceed 0.1% by weight in homogeneous materials. Where designed to be soldered at high temperatures, TI Pb-Free products are suitable for use in specified lead-free processes.

**Pb-Free (RoHS Exempt):** This component has a RoHS exemption for either 1) lead-based flip-chip solder bumps used between the die and package, or 2) lead-based die adhesive used between the die and leadframe. The component is otherwise considered Pb-Free (RoHS compatible) as defined above.

**Green (RoHS & no Sb/Br):** TI defines "Green" to mean Pb-Free (RoHS compatible), and free of Bromine (Br) and Antimony (Sb) based flame retardants (Br or Sb do not exceed 0.1% by weight in homogeneous material)

(3) MSL, Peak Temp. -- The Moisture Sensitivity Level rating according to the JEDEC industry standard classifications, and peak solder temperature.

(4) Multiple Top-Side Markings will be inside parentheses. Only one Top-Side Marking contained in parentheses and separated by a "~" will appear on a device. If a line is indented then it is a continuation of the previous line and the two combined represent the entire Top-Side Marking for that device.

**Important Information and Disclaimer:** The information provided on this page represents TI's knowledge and belief as of the date that it is provided. TI bases its knowledge and belief on information provided by third parties, and makes no representation or warranty as to the accuracy of such information. Efforts are underway to better integrate information from third parties. TI has taken and continues to take reasonable steps to provide representative and accurate information but may not have conducted destructive testing or chemical analysis on incoming materials and chemicals. TI and TI suppliers consider certain information to be proprietary, and thus CAS numbers and other limited information may not be available for release.

In no event shall TI's liability arising out of such information exceed the total purchase price of the TI part(s) at issue in this document sold by TI to Customer on an annual basis.

**TAPE AND REEL INFORMATION**

**QUADRANT ASSIGNMENTS FOR PIN 1 ORIENTATION IN TAPE**

\*All dimensions are nominal

Device	Package Type	Package Drawing	Pins	SPQ	Reel Diameter (mm)	Reel Width W1 (mm)	A0 (mm)	B0 (mm)	K0 (mm)	P1 (mm)	W (mm)	Pin1 Quadrant
UCD90124ARGCR	VQFN	RGC	64	2000	330.0	16.4	9.3	9.3	1.1	12.0	16.0	Q2
UCD90124ARGCR	VQFN	RGC	64	2000	330.0	16.4	9.3	9.3	1.5	12.0	16.0	Q2
UCD90124ARGCT	VQFN	RGC	64	250	180.0	16.4	9.3	9.3	1.5	12.0	16.0	Q2

**TAPE AND REEL BOX DIMENSIONS**

\*All dimensions are nominal

Device	Package Type	Package Drawing	Pins	SPQ	Length (mm)	Width (mm)	Height (mm)
UCD90124ARGCR	VQFN	RGC	64	2000	367.0	367.0	38.0
UCD90124ARGCR	VQFN	RGC	64	2000	367.0	367.0	38.0
UCD90124ARGCT	VQFN	RGC	64	250	210.0	185.0	35.0

## GENERIC PACKAGE VIEW

**RGC 64**

**VQFN - 1 mm max height**

9 x 9, 0.5 mm pitch

PLASTIC QUAD FLATPACK - NO LEAD

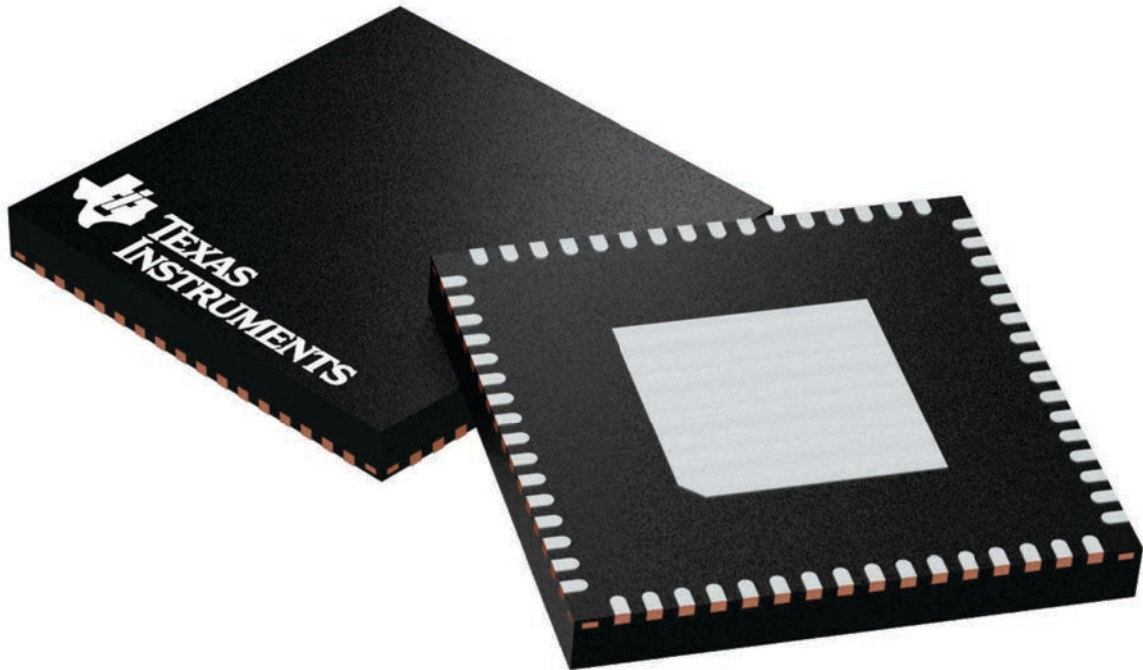

Images above are just a representation of the package family, actual package may vary.  
Refer to the product data sheet for package details.

4224597/A



# EXAMPLE BOARD LAYOUT

RGC0064B

VQFN - 1 mm max height

PLASTIC QUAD FLATPACK - NO LEAD

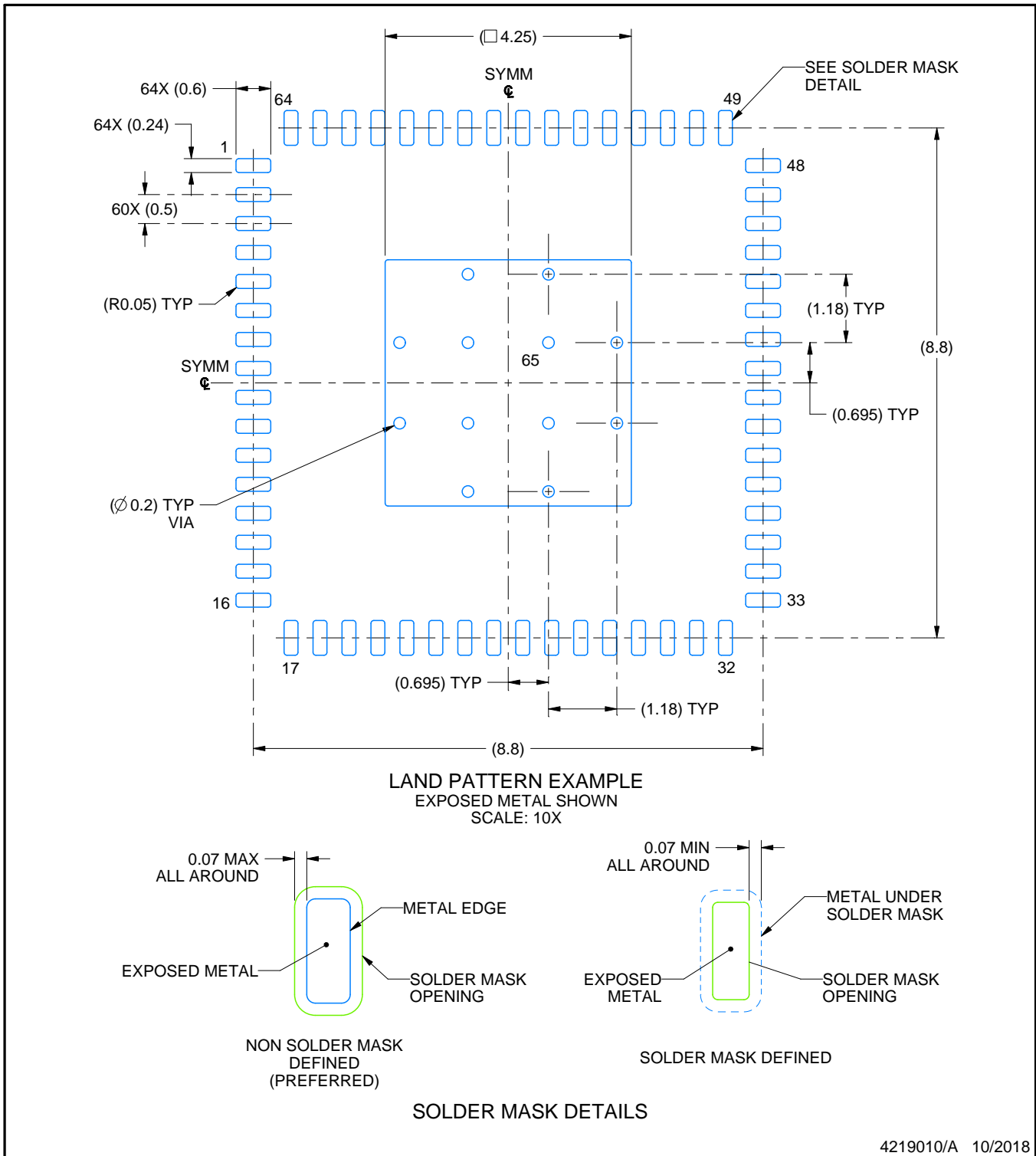

4219010/A 10/2018

NOTES: (continued)

4. This package is designed to be soldered to a thermal pad on the board. For more information, see Texas Instruments literature number SLUA271 ([www.ti.com/lit/sluea271](http://www.ti.com/lit/sluea271)).
5. Vias are optional depending on application, refer to device data sheet. If any vias are implemented, refer to their locations shown on this view. It is recommended that vias under paste be filled, plugged or tented.

# EXAMPLE STENCIL DESIGN

RGC0064B

VQFN - 1 mm max height

PLASTIC QUAD FLATPACK - NO LEAD

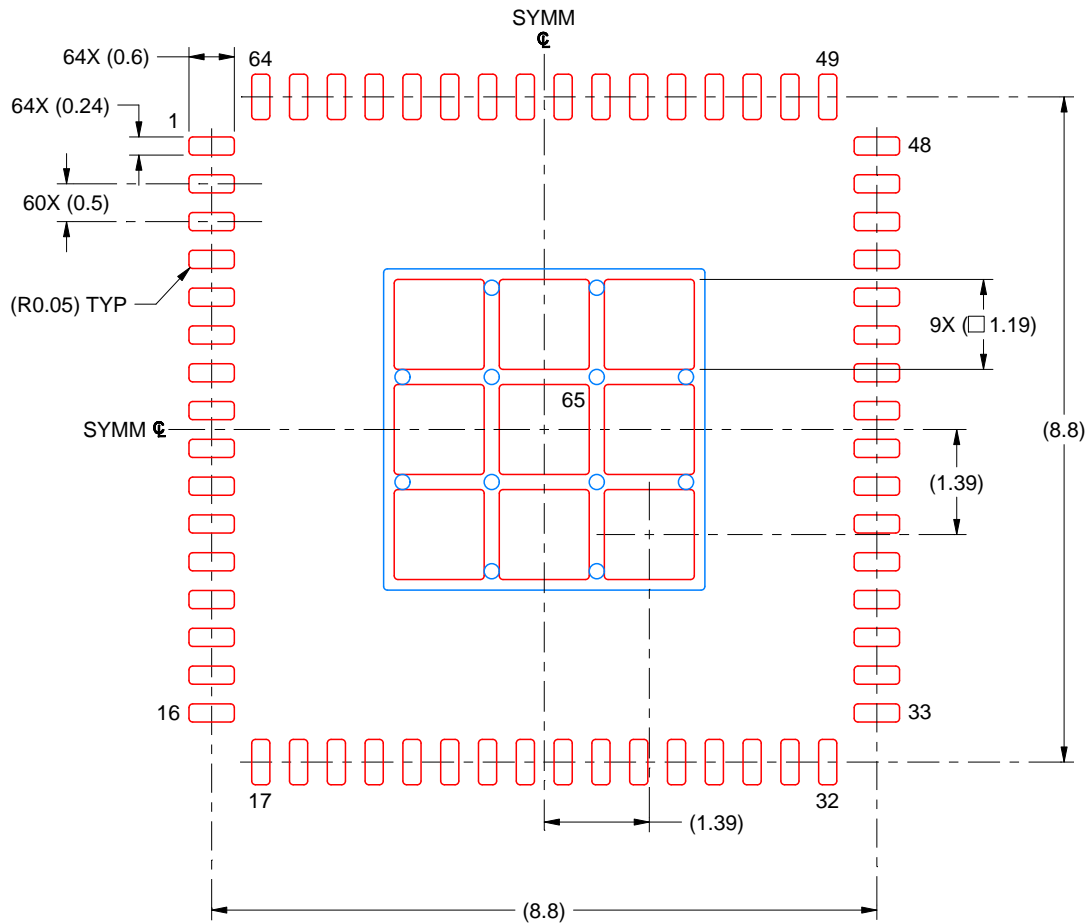

SOLDER PASTE EXAMPLE  
BASED ON 0.125 MM THICK STENCIL  
SCALE: 10X

EXPOSED PAD 65  
71% PRINTED SOLDER COVERAGE BY AREA UNDER PACKAGE

4219010/A 10/2018

NOTES: (continued)

6. Laser cutting apertures with trapezoidal walls and rounded corners may offer better paste release. IPC-7525 may have alternate design recommendations.

## IMPORTANT NOTICE AND DISCLAIMER

TI PROVIDES TECHNICAL AND RELIABILITY DATA (INCLUDING DATASHEETS), DESIGN RESOURCES (INCLUDING REFERENCE DESIGNS), APPLICATION OR OTHER DESIGN ADVICE, WEB TOOLS, SAFETY INFORMATION, AND OTHER RESOURCES "AS IS" AND WITH ALL FAULTS, AND DISCLAIMS ALL WARRANTIES, EXPRESS AND IMPLIED, INCLUDING WITHOUT LIMITATION ANY IMPLIED WARRANTIES OF MERCHANTABILITY, FITNESS FOR A PARTICULAR PURPOSE OR NON-INFRINGEMENT OF THIRD PARTY INTELLECTUAL PROPERTY RIGHTS.

These resources are intended for skilled developers designing with TI products. You are solely responsible for (1) selecting the appropriate TI products for your application, (2) designing, validating and testing your application, and (3) ensuring your application meets applicable standards, and any other safety, security, or other requirements. These resources are subject to change without notice. TI grants you permission to use these resources only for development of an application that uses the TI products described in the resource. Other reproduction and display of these resources is prohibited. No license is granted to any other TI intellectual property right or to any third party intellectual property right. TI disclaims responsibility for, and you will fully indemnify TI and its representatives against, any claims, damages, costs, losses, and liabilities arising out of your use of these resources.

TI's products are provided subject to TI's Terms of Sale ([www.ti.com/legal/termsofsale.html](http://www.ti.com/legal/termsofsale.html)) or other applicable terms available either on [ti.com](http://ti.com) or provided in conjunction with such TI products. TI's provision of these resources does not expand or otherwise alter TI's applicable warranties or warranty disclaimers for TI products.

Mailing Address: Texas Instruments, Post Office Box 655303, Dallas, Texas 75265  
Copyright © 2018, Texas Instruments Incorporated

## Looking for pricing, stock, or lifecycle information?

Click below to explore more details on WIN SOURCE:

 [View UCD90124ARGCR on WIN SOURCE](#)

 [Texas Instruments](#) Information

## Optimize Your Supply Chain with WIN SOURCE Solutions

-  Global Sourcing Solution
-  Obsolete Management
-  Cost Control Management
-  Shortage Management
-  Alternative Solution
-  Excess Inventory Management