



THE DATASHEET OF SN74BCT25245DWR



SN54BCT25245, SN74BCT25245 25-Ω OCTAL BUS TRANSCEIVERS WITH 3-STATE OUTPUTS

SCBS053B – MAY 1990 – REVISED APRIL 1994

- State-of-the-Art BiCMOS Design Significantly Reduces I_{CCZ}
- ESD Protection Exceeds 2000 V Per MIL-STD-883C, Method 3015; Exceeds 200 V Using Machine Model ($C = 200$ pF, $R = 0$)
- Designed to Facilitate Incident-Wave Switching for Line Impedances of 25 Ω or Greater
- Distributed V_{CC} and GND Pins Minimize Noise Generated by the Simultaneous Switching of Outputs
- Package Options Include Plastic Small-Outline (DW) Packages, Ceramic Chip Carriers (FK) and Flatpacks (W), and Standard Plastic and Ceramic 300-mil DIPs (JT, NT)

SN54BCT25245 . . . JT OR W PACKAGE
SN74BCT25245 . . . DW OR NT PACKAGE
(TOP VIEW)

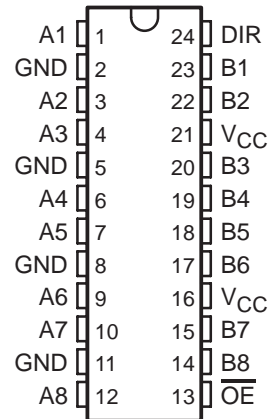

SN54BCT25245 . . . FK PACKAGE
(TOP VIEW)

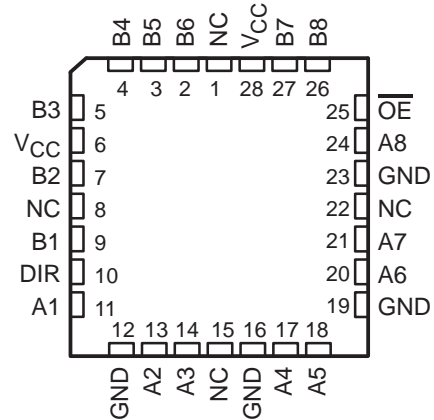

NC – No internal connection

description

The 'BCT25245 is a 25-Ω octal bus transceiver designed for asynchronous communication between data buses. It improves both the performance and density of 3-state memory address drivers, clock drivers, and bus-oriented transceivers.

The device allows data transmission from the A bus to the B bus or from the B bus to the A bus depending upon the logic level at the direction-control (DIR) input. The output-enable (\overline{OE}) input can disable the device so that both buses are effectively isolated.

These transceivers are capable of sinking 188-mA I_{OL} , which facilitates switching 25-Ω transmission lines on the incident wave. The distributed V_{CC} and GND pins minimize switching noise for more reliable system operation.

The SN54BCT25245 is characterized for operation over the full military temperature range of -55°C to 125°C. The SN74BCT25245 is characterized for operation from 0°C to 70°C.

FUNCTION TABLE

INPUTS		OPERATION
\overline{OE}	DIR	
L	L	B data to A bus
L	H	A data to B bus
H	X	Isolation

UNLESS OTHERWISE NOTED this document contains PRODUCTION DATA information current as of publication date. Products conform to specifications per the terms of Texas Instruments standard warranty. Production processing does not necessarily include testing of all parameters.



Copyright © 1994, Texas Instruments Incorporated

SN54BCT25245, SN74BCT25245 25-Ω OCTAL BUS TRANSCEIVERS WITH 3-STATE OUTPUTS

SCBS053B – MAY 1990 – REVISED APRIL 1994

logic symbol†

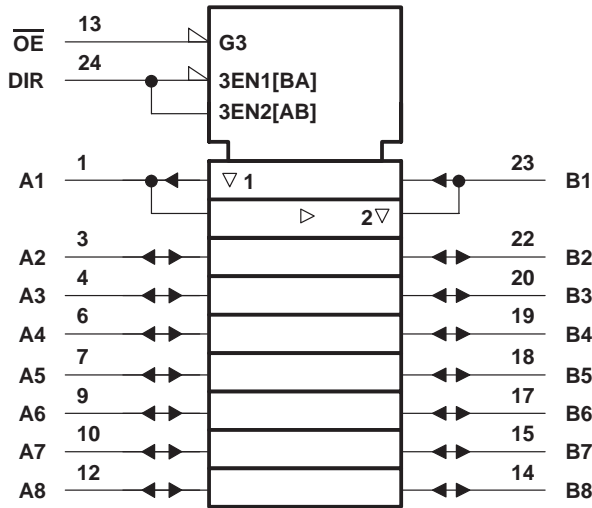

logic diagram (positive logic)

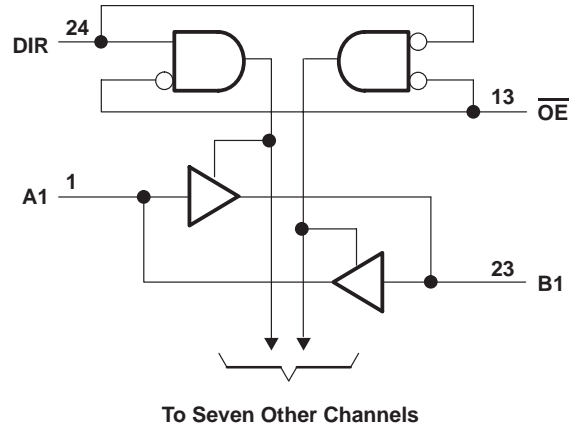

† This symbol is in accordance with ANSI/IEEE Std 91-1984 and IEC Publication 617-12.

Pin numbers shown are for the DW, JT, NT, and W packages.

absolute maximum ratings over operating free-air temperature range (unless otherwise noted)‡

Supply voltage range, V_{CC}	-0.5 V to 7 V
Input voltage range, V_I (see Note 1): Control inputs	-0.5 V to 7 V
I/O ports	-0.5 V to 5.5 V
Voltage range applied to any output in the disabled or power-off state, V_O	-0.5 V to 5.5 V
Voltage range applied to any output in the high state, V_O (B port)	-0.5 V to V_{CC}
Input clamp current, I_{IK}	-30 mA
Current into any output in the low state, I_O : SN54BCT25245 (A port)	250 mA
SN54BCT25245 (B port)	40 mA
SN74BCT25245 (A port)	376 mA
SN74BCT25245 (B port)	48 mA
Operating free-air temperature range: SN54BCT25245	-55°C to 125°C
SN74BCT25245	0°C to 70°C
Storage temperature range	-65°C to 150°C

‡ Stresses beyond those listed under "absolute maximum ratings" may cause permanent damage to the device. These are stress ratings only, and functional operation of the device at these or any other conditions beyond those indicated under "recommended operating conditions" is not implied. Exposure to absolute-maximum-rated conditions for extended periods may affect device reliability.

NOTE 1: The input and output negative-voltage ratings may be exceeded if the input and output clamp-current ratings are observed.

SN54BCT25245, SN74BCT25245 25-Ω OCTAL BUS TRANSCEIVERS WITH 3-STATE OUTPUTS

SCBS053B – MAY 1990 – REVISED APRIL 1994

recommended operating conditions

		SN54BCT25245			SN74BCT25245			UNIT
		MIN	NOM	MAX	MIN	NOM	MAX	
V _{CC}	Supply voltage	4.5	5	5.5	4.5	5	5.5	V
V _{IH}	High-level input voltage	2			2			V
V _{IL}	Low-level input voltage			0.8			0.8	V
I _{IK}	Input clamp current			-18			-18	mA
I _{OH}	High-level output current	A port		-53	B port		-80	mA
		B port		-3	A port		-3	
I _{OL}	Low-level output current	A port		125	B port		188	mA
		B port		20	A port		24	
T _A	Operating free-air temperature	-55		125	0		70	°C

electrical characteristics over recommended operating free-air temperature range (unless otherwise noted)

PARAMETER		TEST CONDITIONS		SN54BCT25245			SN74BCT25245			UNIT
				MIN	TYP†	MAX	MIN	TYP†	MAX	
V _{IK}		V _{CC} = 4.5 V, I _I = -18 mA		-1.2			-1.2			V
V _{OH}	A port	V _{CC} = 4.5 V	I _{OH} = -53 mA	2						V
			I _{OH} = -80 mA				2			
	V _{CC} = 4.75 V, I _{OH} = -3 mA				2.7					
B port	V _{CC} = 4.5 V, I _{OH} = -3 mA	2.4	3.3	2.4	3.3					
V _{OL}	A port	V _{CC} = 4.5 V	I _{OL} = 94 mA	0.38	0.55	0.42	0.55		V	
			I _{OL} = 125 mA	0.8						
			I _{OL} = 188 mA				0.7			
	B port	V _{CC} = 4.5 V	I _{OL} = 20 mA	0.3	0.5					
			I _{OL} = 24 mA				0.35	0.5		
I _I	A or B port	V _{CC} = 5.5 V, V _I = 5.5 V		0.25			0.25			mA
Control input	V _{CC} = 5.5 V, V _I = 5.5 V		0.1			0.1				
I _{IH} ‡	A or B port	V _{CC} = 5.5 V, V _I = 2.7 V		70			70			μA
	Control input	V _{CC} = 5.5 V, V _I = 2.7 V		20			20			
I _{IL} ‡	A or B port	V _{CC} = 5.5 V, V _I = 0.5 V		-0.6			-0.6			mA
	Control input	V _{CC} = 5.5 V, V _I = 0.5 V		-0.6			-0.6			
I _{OS} §	B port only¶	V _{CC} = 5.5 V, V _O = 0		-60	-150	-60	-150		mA	
I _{CCH}	A to B	V _{CC} = 5.5 V		36	46	36	46		mA	
	B to A	V _{CC} = 5.5 V		63	80	63	80			
I _{CCL}	A to B	V _{CC} = 5.5 V		48	60	48	60		mA	
	B to A	V _{CC} = 5.5 V		95	125	95	125			
I _{CCZ}		V _{CC} = 5.5 V		12	16	12	16		mA	
C _i	Control input	V _{CC} = 5 V, V _I = 2.5 V or 0.5 V		8			8			pF
C _{io}	A port	V _{CC} = 5 V, V _O = 2.5 V or 0.5 V		18			18			pF
	B port	V _{CC} = 5 V, V _O = 2.5 V or 0.5 V		8			8			

† All typical values are at V_{CC} = 5 V, T_A = 25°C.

‡ For I/O ports, the parameters I_{IH} and I_{IL} include the off-state output current.

§ Not more than one output should be tested at a time, and the duration of the test should not exceed one second.

¶ Testing for this parameter on the A port is not recommended.

PRODUCT PREVIEW information concerns products in the formative or design phase of development. Characteristic data and other specifications are design goals. Texas Instruments reserves the right to change or discontinue these products without notice.



SN54BCT25245, SN74BCT25245

25-Ω OCTAL BUS TRANSCEIVERS

WITH 3-STATE OUTPUTS

SCBS053B – MAY 1990 – REVISED APRIL 1994

switching characteristics (see Note 2)

PARAMETER	FROM (INPUT)	TO (OUTPUT)	V _{CC} = 5 V, C _L = 50 pF, R ₁ = 500 Ω, R ₂ = 500 Ω, T _A = 25°C			V _{CC} = 4.5 V to 5.5 V, C _L = 50 pF, R ₁ = 500 Ω, R ₂ = 500 Ω, T _A = MIN to MAX†			UNIT	
			74BCT25245			SN54BCT25245		SN74BCT25245		
			MIN	TYP	MAX	MIN	MAX	MIN		MAX
t _{PLH}	A	B	1.2	3.3	5.1	1.2	5.8	1.2	5.7	ns
t _{PHL}			1.9	4.3	6.7	1.9	7.6	1.9	7.2	
t _{PLH}	B	A	1.2	3.3	4.8	1.2	5.7	1.2	5.5	ns
t _{PHL}			2.1	4	5.6	2.1	6.4	2.1	6.2	
t _{PZH}	$\overline{\text{OE}}$	A	3.7	6.3	8.4	3.7	10.1	3.7	9.6	ns
t _{PZL}			4.5	7.4	9.2	4.5	11.1	4.5	10.3	
t _{PHZ}	$\overline{\text{OE}}$	A	1.8	3.7	5.5	1.8	6.4	1.8	6.2	ns
t _{PLZ}			3.3	5.1	7.2	3.3	9.6	3.3	8.3	
t _{PZH}	$\overline{\text{OE}}$	B	3.4	5.7	7.9	3.4	9.2	3.4	8.9	ns
t _{PZL}			4.3	6.6	8.7	4.3	10.1	4.3	9.7	
t _{PHZ}	$\overline{\text{OE}}$	B	2.7	4.5	6.3	2.7	7.2	2.7	6.9	ns
t _{PLZ}			1.7	4.5	6.8	1.7	8.3	1.7	7.5	

† For conditions shown as MIN or MAX, use the appropriate value specified under recommended operating conditions.

NOTE 2: Load circuits and voltage waveforms are shown in Section 1.

PRODUCT PREVIEW information concerns products in the formative or design phase of development. Characteristic data and other specifications are design goals. Texas Instruments reserves the right to change or discontinue these products without notice.



POST OFFICE BOX 655303 • DALLAS, TEXAS 75265
POST OFFICE BOX 1443 • HOUSTON, TEXAS 77251-1443

TAPE AND REEL INFORMATION

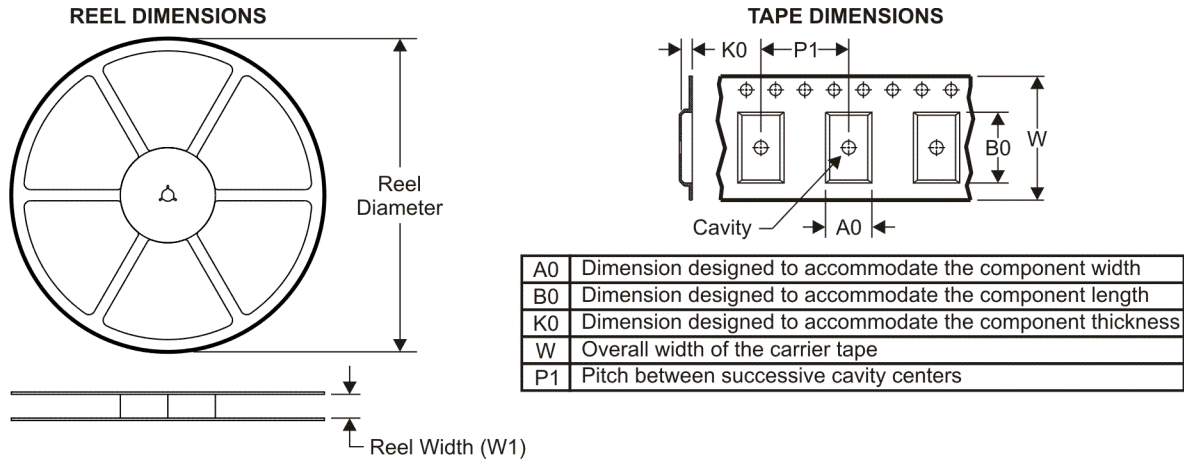

QUADRANT ASSIGNMENTS FOR PIN 1 ORIENTATION IN TAPE

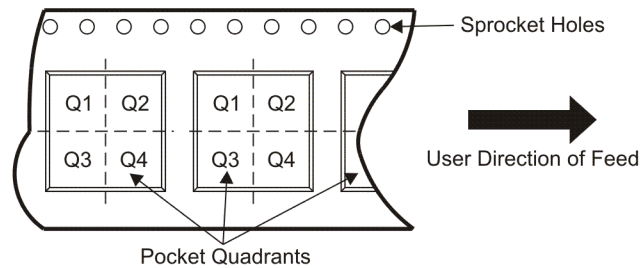

*All dimensions are nominal

Device	Package Type	Package Drawing	Pins	SPQ	Reel Diameter (mm)	Reel Width W1 (mm)	A0 (mm)	B0 (mm)	K0 (mm)	P1 (mm)	W (mm)	Pin1 Quadrant
SN74BCT25245DWR	SOIC	DW	24	2000	330.0	24.4	10.75	15.7	2.7	12.0	24.0	Q1

TAPE AND REEL BOX DIMENSIONS



*All dimensions are nominal

Device	Package Type	Package Drawing	Pins	SPQ	Length (mm)	Width (mm)	Height (mm)
SN74BCT25245DWR	SOIC	DW	24	2000	346.0	346.0	41.0

IMPORTANT NOTICE

Texas Instruments Incorporated and its subsidiaries (TI) reserve the right to make corrections, modifications, enhancements, improvements, and other changes to its products and services at any time and to discontinue any product or service without notice. Customers should obtain the latest relevant information before placing orders and should verify that such information is current and complete. All products are sold subject to TI's terms and conditions of sale supplied at the time of order acknowledgment.

TI warrants performance of its hardware products to the specifications applicable at the time of sale in accordance with TI's standard warranty. Testing and other quality control techniques are used to the extent TI deems necessary to support this warranty. Except where mandated by government requirements, testing of all parameters of each product is not necessarily performed.

TI assumes no liability for applications assistance or customer product design. Customers are responsible for their products and applications using TI components. To minimize the risks associated with customer products and applications, customers should provide adequate design and operating safeguards.

TI does not warrant or represent that any license, either express or implied, is granted under any TI patent right, copyright, mask work right, or other TI intellectual property right relating to any combination, machine, or process in which TI products or services are used. Information published by TI regarding third-party products or services does not constitute a license from TI to use such products or services or a warranty or endorsement thereof. Use of such information may require a license from a third party under the patents or other intellectual property of the third party, or a license from TI under the patents or other intellectual property of TI.

Reproduction of TI information in TI data books or data sheets is permissible only if reproduction is without alteration and is accompanied by all associated warranties, conditions, limitations, and notices. Reproduction of this information with alteration is an unfair and deceptive business practice. TI is not responsible or liable for such altered documentation. Information of third parties may be subject to additional restrictions.

Resale of TI products or services with statements different from or beyond the parameters stated by TI for that product or service voids all express and any implied warranties for the associated TI product or service and is an unfair and deceptive business practice. TI is not responsible or liable for any such statements.

TI products are not authorized for use in safety-critical applications (such as life support) where a failure of the TI product would reasonably be expected to cause severe personal injury or death, unless officers of the parties have executed an agreement specifically governing such use. Buyers represent that they have all necessary expertise in the safety and regulatory ramifications of their applications, and acknowledge and agree that they are solely responsible for all legal, regulatory and safety-related requirements concerning their products and any use of TI products in such safety-critical applications, notwithstanding any applications-related information or support that may be provided by TI. Further, Buyers must fully indemnify TI and its representatives against any damages arising out of the use of TI products in such safety-critical applications.

TI products are neither designed nor intended for use in military/aerospace applications or environments unless the TI products are specifically designated by TI as military-grade or "enhanced plastic." Only products designated by TI as military-grade meet military specifications. Buyers acknowledge and agree that any such use of TI products which TI has not designated as military-grade is solely at the Buyer's risk, and that they are solely responsible for compliance with all legal and regulatory requirements in connection with such use.

TI products are neither designed nor intended for use in automotive applications or environments unless the specific TI products are designated by TI as compliant with ISO/TS 16949 requirements. Buyers acknowledge and agree that, if they use any non-designated products in automotive applications, TI will not be responsible for any failure to meet such requirements.

Following are URLs where you can obtain information on other Texas Instruments products and application solutions:

Products

Amplifiers	amplifier.ti.com
Data Converters	dataconverter.ti.com
DLP® Products	www.dlp.com
DSP	dsp.ti.com
Clocks and Timers	www.ti.com/clocks
Interface	interface.ti.com
Logic	logic.ti.com
Power Mgmt	power.ti.com
Microcontrollers	microcontroller.ti.com
RFID	www.ti-rfid.com
RF/IF and ZigBee® Solutions	www.ti.com/lprf

Applications

Audio	www.ti.com/audio
Automotive	www.ti.com/automotive
Broadband	www.ti.com/broadband
Digital Control	www.ti.com/digitalcontrol
Medical	www.ti.com/medical
Military	www.ti.com/military
Optical Networking	www.ti.com/opticalnetwork
Security	www.ti.com/security
Telephony	www.ti.com/telephony
Video & Imaging	www.ti.com/video
Wireless	www.ti.com/wireless

Mailing Address: Texas Instruments, Post Office Box 655303, Dallas, Texas 75265
Copyright © 2009, Texas Instruments Incorporated

Looking for pricing, stock, or lifecycle information?

Click below to explore more details on WIN SOURCE:

 [View SN74BCT25245DWR on WIN SOURCE](#)

 [Texas Instruments](#) Information

Optimize Your Supply Chain with WIN SOURCE Solutions

-  Global Sourcing Solution
-  Obsolete Management
-  Cost Control Management
-  Shortage Management
-  Alternative Solution
-  Excess Inventory Management