

Mobile Phone Module Driver

Parallel Interface Type Lens Driver for Stepping Motor

BD6360GUL

General Description

The BD6360GUL is a motor driver with dual, built-in Full-ON type two H-Bridges. It also has a power supply function for photo-interrupter to detect motor position and wave-shaping circuit built-in. This small surface mounting package CSP is most suitable for mobile system and home appliance.

Features

- Low ON-Resistance Power CMOS Output
- ESD Protection: 8kV, Human Body Model (HBM)
- Drive Mode Switch Function
- Control Input Pins Fit the Signal of 1.8V System
- Voltage-Regulator for Photo-Interrupter and Comparator with Hysteresis to Convert to Sharp Waveform
- Under Voltage Locked Out protection & Thermal Shut Down Circuit

Applications

- Mobile system
- Home appliance
- Amusement system, etc

Key Specifications

- Power Supply Voltage Range: 2.3V to 5.5V
- Circuit Current (No load): 1.1mA(Typ)
- Stand-By Current: 5µA (Max)
- Control Input Voltage Range: 0V to V_{CC}V
- H-Bridge Output Current: -0.4A to +0.4A
- Output ON-Resistance (Total): 1.0Ω(Typ)
- Operating Temperature Range: -25°C to +85°C

Package

VCSP50L2

W(Typ) x D(Typ) x H(Max)

2.10mm x 2.10mm x 0.55mm



Typical Application Circuit

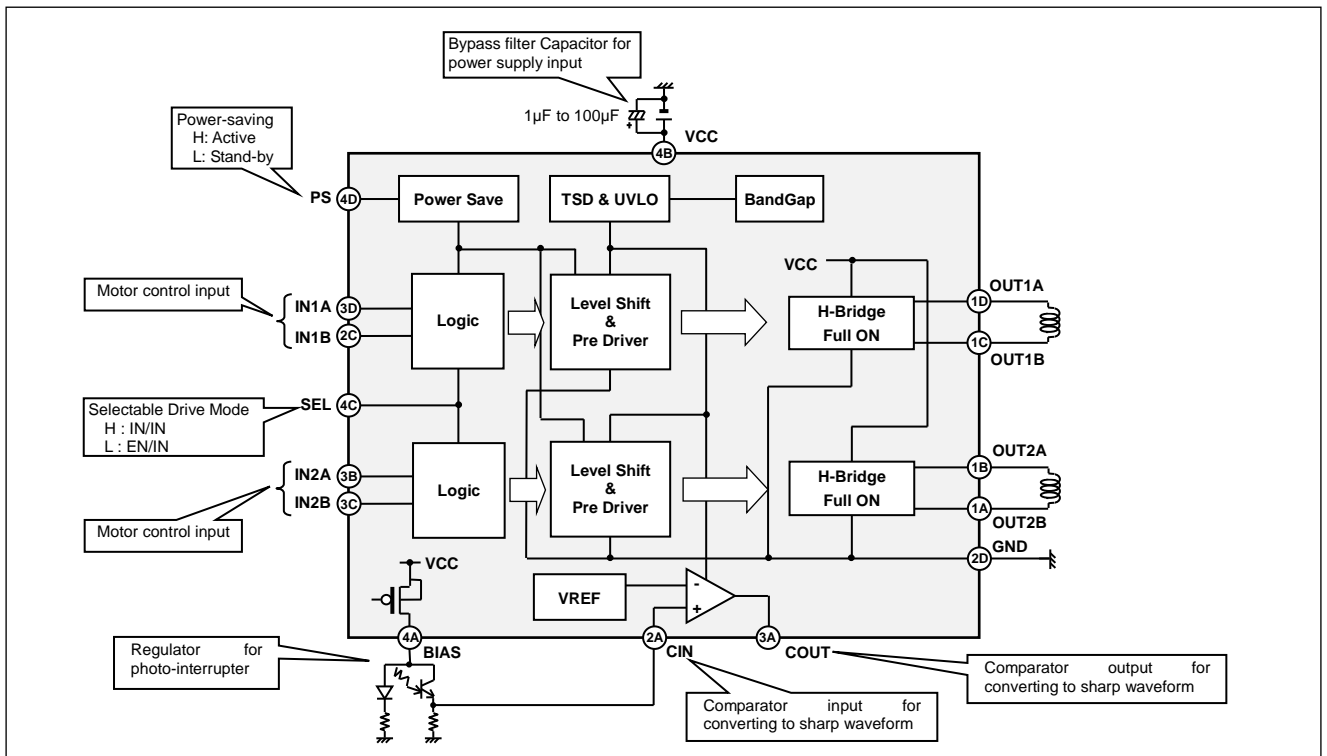

Pin Configuration

(TOP VIEW)

	1	2	3	4
A	OUT2B	CIN	COUT	BIAS
B	OUT2A	INDEX POST	IN2A	VCC
C	OUT1B	IN1B	IN2B	SEL
D	OUT1A	GND	IN1A	PS

Pin Descriptions

Pin No.	Pin Name	Function
1A	OUT2B	H-bridge output 2B
2A	CIN	Comparator input for sharp waveform
3A	COUT	Comparator output for sharp waveform
4A	BIAS	Voltage-regulator for photo-interrupter
1B	OUT2A	H-bridge output 2A
2B	INDEX POST	
3B	IN2A	Control logic input 2A
4B	VCC	Power supply
1C	OUT1B	H-bridge output 1B
2C	IN1B	Control logic input 1B
3C	IN2B	Control logic input 2B
4C	SEL	Drive mode switch function
1D	OUT1A	H-bridge output 1A
2D	GND	Ground
3D	IN1A	Control logic input 1A
4D	PS	Power-saving function

Block Diagram

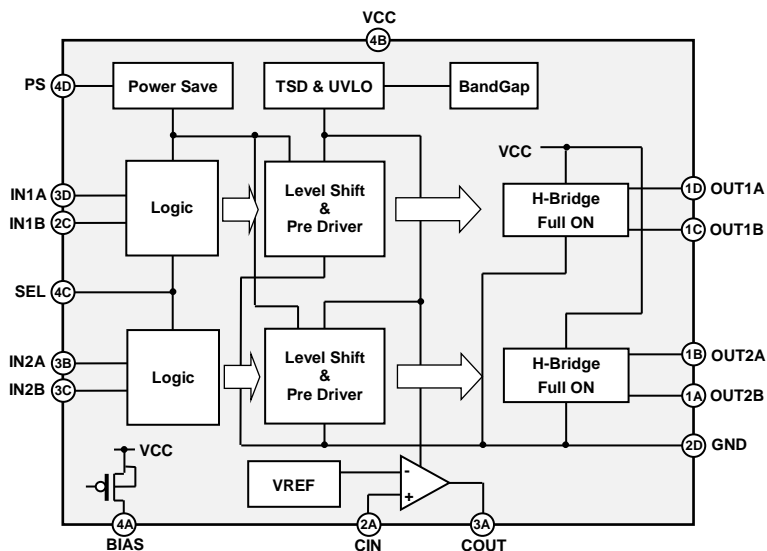

Description of Blocks

1. Power-Saving Function
A power-saving function is included, which allows the system to save power when not driving the motor. The voltage level on this pin should be set high so as to keep the operation mode. (See the Electrical Characteristics; p.4/14)
2. Motor Control Input
 - (a) IN1A, IN1B, IN2A and IN2B pin
Logic level controls the output logic of H-Bridge.
(See the Electrical Characteristics; p.4/14, and I/O Truth Table; p.7/14)
 - (b) SEL pin
Logic level sets the IN/IN or EN/IN drive mode.
(See the Electrical Characteristics; p.4/14 and I/O Truth Table; p.7/14)
3. Photo-Interrupter Regulator
The BIAS pin can output VCC voltage for photo-interrupter during the operation mode.
When connecting photo-interrupter to this pin, pay attention to the ON resistance of internal power transistor.
(See the Typical Performance Curves; p.6/14)

Absolute Maximum Ratings (Ta=25°C)

Parameter	Symbol	Limit	Unit
Power Supply Voltage	V _{CC}	-0.3 to +6.5	V
Control Input Voltage	V _{IN}	-0.3 to +V _{CC} +0.3	V
Power Dissipation	P _d	0.73 (Note 1)	W
H-bridge Output Current	I _{OUT}	-0.5 to +0.5 (Note 2)	A/ch
Storage Temperature Range	T _{stg}	-55 to +150	°C
Junction Temperature	T _{jmax}	150	°C

(Note 1) Reduced by 5.84mW/°C over 25°C, when mounted on a glass epoxy board (50mm x 58mm x 1.75mm; 8layers)

(Note 2) Must not exceed P_d, A_{SO}, or T_{jmax} of 150°C

Caution: Operating the IC over the absolute maximum ratings may damage the IC. The damage can either be a short circuit between pins or an open circuit between pins and the internal circuitry. Therefore, it is important to consider circuit protection measures, such as adding a fuse, in case the IC is operated over the absolute maximum ratings.

Recommended Operating Conditions

Parameter	Symbol	Min	Typ	Max	Unit
Power Supply Voltage	V _{CC}	2.3	-	5.5	V
Control Input Voltage	V _{IN}	0	-	V _{CC}	V
H-bridge Output Current ^(Note 3)	I _{OUT}	-0.4	-	+0.4	A/ch
Operating Temperature Range	T _{opr}	-25	-	+85	°C

(Note 3) Must not exceed P_d, A_{SO}, or T_{jmax} of 150°C

Electrical Characteristics (Unless otherwise specified $V_{CC}=3.0V$, $T_a=25^{\circ}C$)

Parameter	Symbol	Min	Typ	Max	Unit	Conditions
All Circuits						
Stand-by Current	I_{CCST}	-	0	5	μA	$V_{PS}=0V$
Circuit Current	I_{CC}	-	1.1	1.8	mA	$V_{PS}=3V$ with no signal & no load
Control Input (IN=PS, IN1A, IN1B, IN2A, IN2B, SEL)						
High Level Input Voltage	V_{INH}	1.5	-	V_{CC}	V	
Low Level Input Voltage	V_{INL}	0	-	0.5	V	
High Level Input Current	I_{INH}	15	30	60	μA	$V_{IN}=3V$
Low Level Input Current	I_{INL}	-1	0	-	μA	$V_{IN}=0V$
Under Voltage Locked Out (UVLO)						
UVLO Voltage	V_{UVLO}	1.6	-	2.2	V	
Comparator for Photo-Interrupter						
Input Bias Current	I_{BIPI}	-3	0	+3	μA	
Output Low Level Voltage	V_{LOPI}	0	-	0.5	V	$I_{OUT}=+1mA$
Output High Level Voltage	V_{HIPI}	$V_{CC}-0.5$	-	V_{CC}	V	$I_{OUT}=-1mA$
Threshold Voltage	V_{THPI}	1.2	1.3	1.4	V	Low to High threshold voltage
Hysteresis Voltage	V_{HYSPI}	200	300	400	mV	High to Low threshold voltage - V_{THPI}
Regulator for Photo-Interrupter						
ON-Resistance	R_{ONSW}	-	-	10	Ω	$I_{OUT}=-30mA$
OFF Current	I_{LSW}	-1.0	0	-	μA	$V_{BIAS}=0V$
Full-ON Drive Block						
Output ON-Resistance	R_{ON}	-	1.00	1.25	Ω	$I_{OUT}=\pm 400mA$, High & Low-side total
Turn-ON Time	t_{ON}	-	0.6	2.0	μs	$I_{OUT}=\pm 400mA$
Turn-OFF Time	t_{OFF}	-	0.08	0.5	μs	$I_{OUT}=\pm 400mA$
Rise Time	t_R	0.1	0.15	1.0	μs	$I_{OUT}=\pm 400mA$
Fall Time	t_F	-	0.03	0.2	μs	$I_{OUT}=\pm 400mA$

Typical Performance Curves (Reference Data)

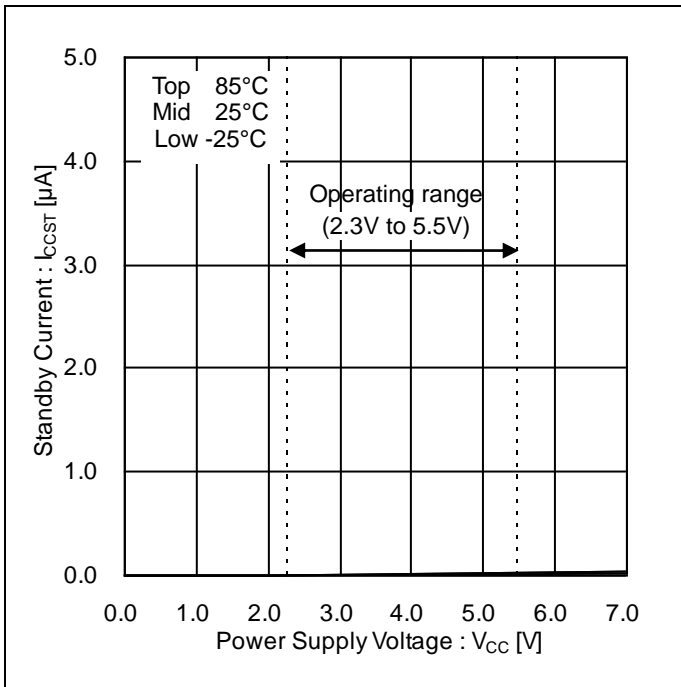

Figure 1.
Standby Current vs Supply Voltage

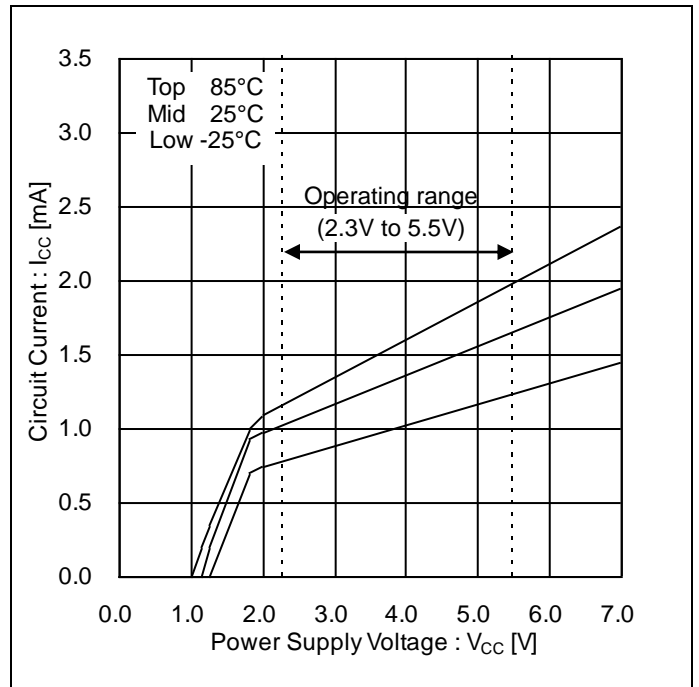

Figure 2.
Circuit Current vs Supply Voltage

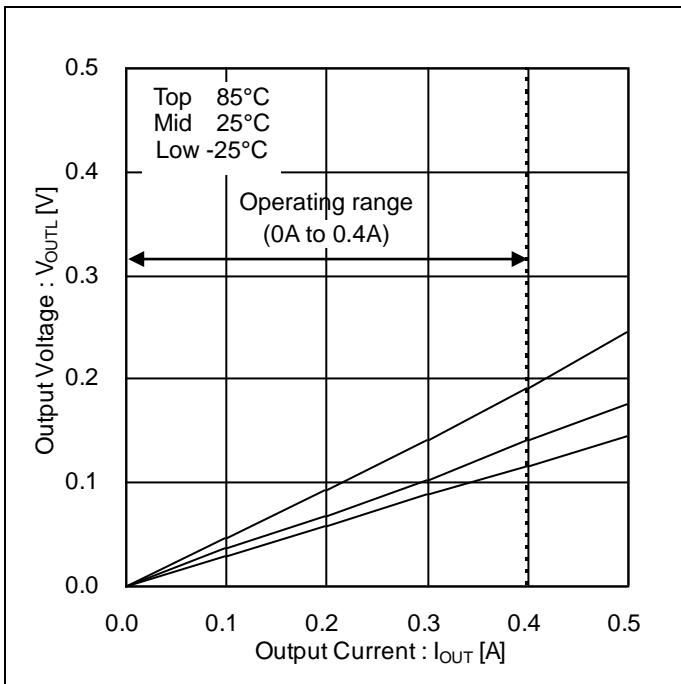

Figure 3.
Low Side Output Voltage vs Output Current

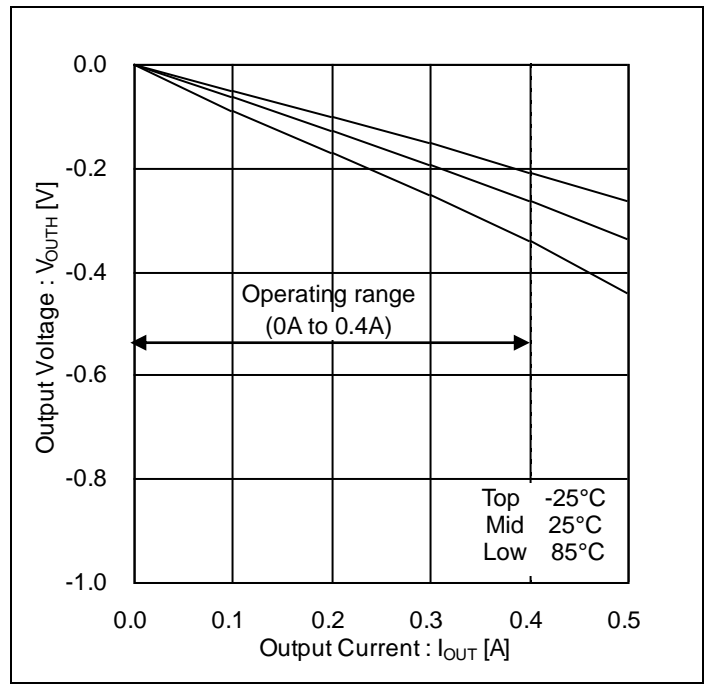

Figure 4.
High Side Output Voltage vs Output Current

Typical Performance Curves (Reference Data) - continued

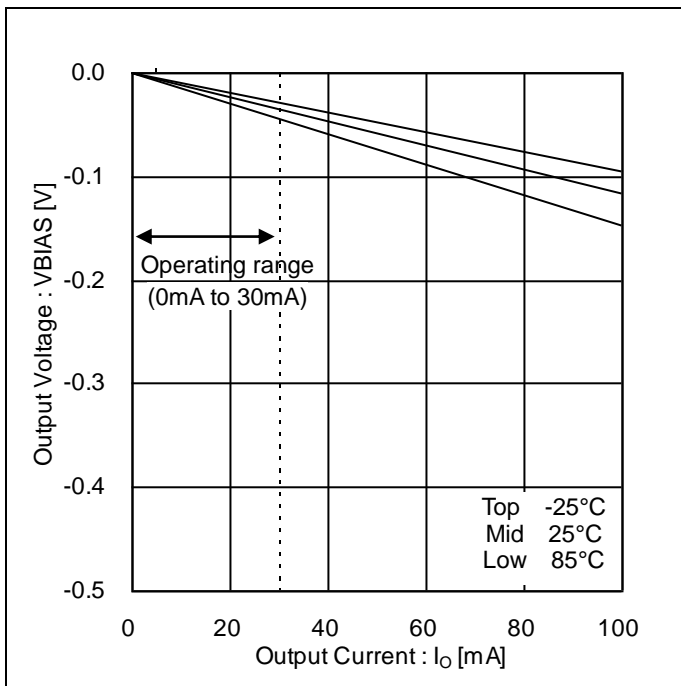

Figure 5.
Regulator Output Voltage vs Output Current

Timing Chart

Table 1. I/O Truth Table

Input Mode	INPUT				OUTPUT			
	PS ^(Note 4)	SEL	IN1A/2A	IN1B/2B	OUT1A/2A	OUT1B/2B	Output Mode ^(Note 5)	
EN/IN	H	L	L	X	Z	Z	Open	
			H	L	H	L	CW	
			H	H	L	H	CCW	
IN/IN		H	H	L	L	Z	Z	Open
				H	L	H	L	CW
				L	H	L	H	CCW
	H			H	L	L	Short Brake	
-	L	X	X	X	Z	Z	Open	

L: Low, H: High, X: Don't care, Z: Hi impedance

(Note 4)PS=High: Operation Mode, PS=Low: Stand-by Mode

(Note 5)CW: Current flows from OUTxA to OUTxB, CCW: Current flows from OUTxB to OUTxA (x=1, 2)

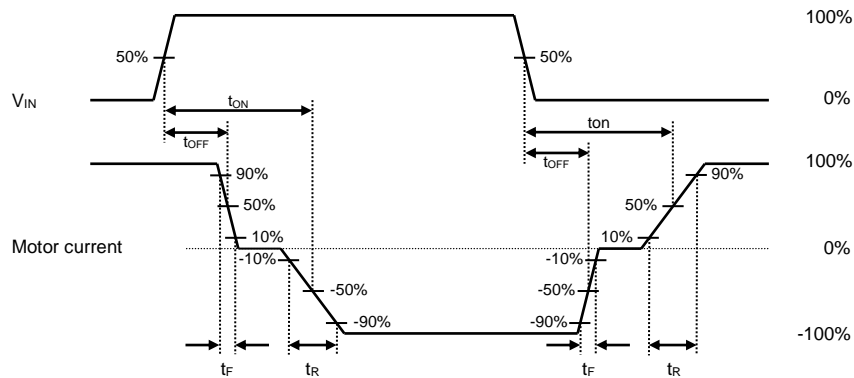

Figure 6. Input-Output AC Characteristic

The Wave-Shaping Circuit Convert

The wave-shaping circuit converts the distorted output signal of the photo-interrupter into rectangular wave. The hysteresis function prevents chatter of the output signal by the noise included in the input signal. This function enables to output the rectangular signal.

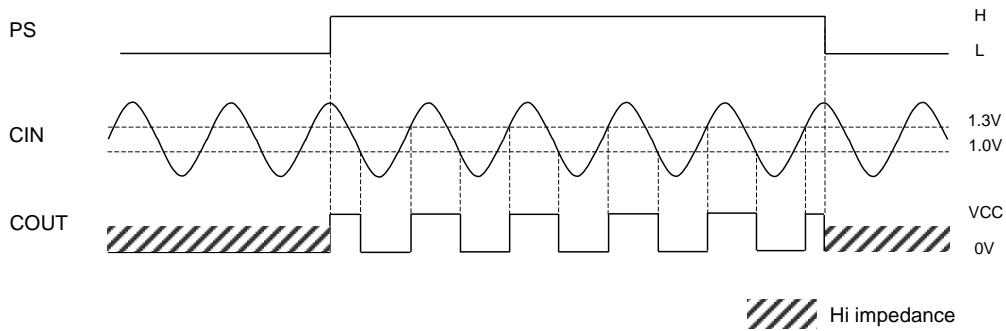
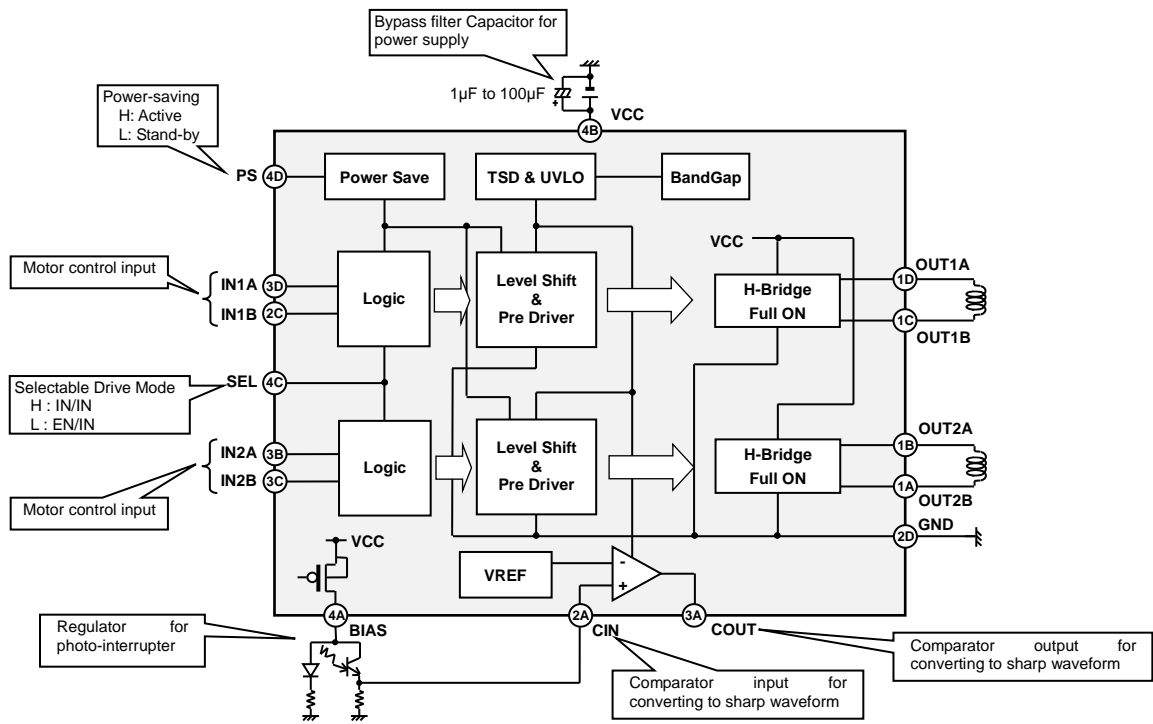

Figure 7. Photo-Interrupter I/O Timing Chart

Application Example



Selection of Components Externally Connected

When using the circuit with changes to the external circuit constants, make sure to leave an adequate margin for external components including static and transitional characteristics as well as dispersion of the IC.

Power Dissipation

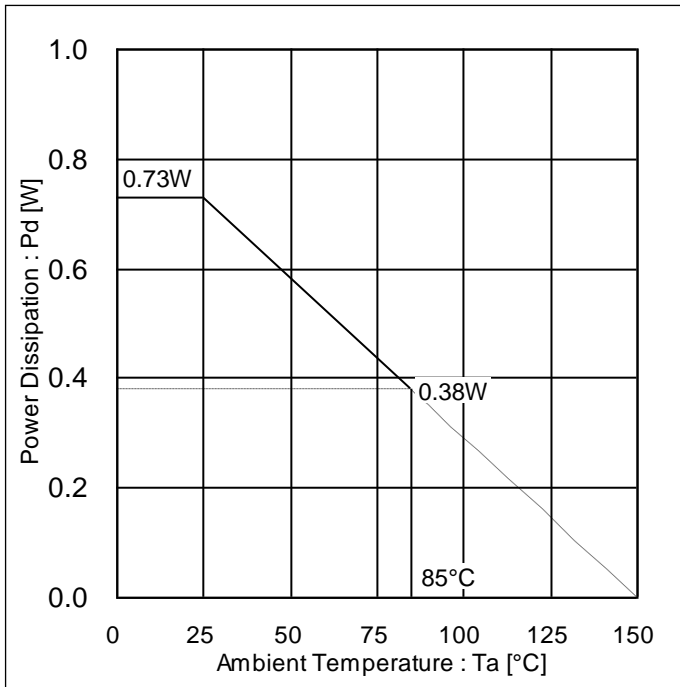
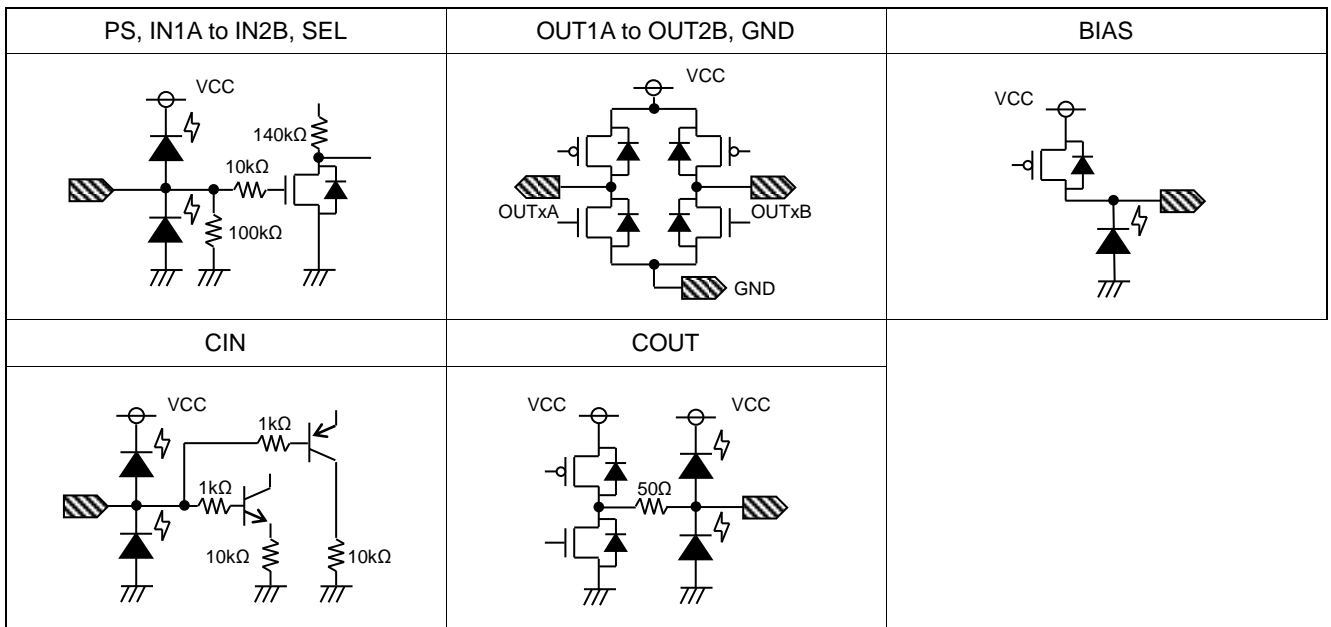

Figure 8.
Power Dissipation vs Ambient Temperature

I/O Equivalence Circuits



Operational Notes

1. Reverse Connection of Power Supply

Connecting the power supply in reverse polarity can damage the IC. Take precautions against reverse polarity when connecting the power supply, such as mounting an external diode between the power supply and the IC's power supply pins.

2. Power Supply Lines

Design the PCB layout pattern to provide low impedance supply lines. Separate the ground and supply lines of the digital and analog blocks to prevent noise in the ground and supply lines of the digital block from affecting the analog block. Furthermore, connect a capacitor to ground at all power supply pins. Consider the effect of temperature and aging on the capacitance value when using electrolytic capacitors.

3. Ground Voltage

Ensure that no pins are at a voltage below that of the ground pin at any time, even during transient condition.

4. Ground Wiring Pattern

When using both small-signal(GND) and large-current ground(PGND) traces, the two ground traces should be routed separately but connected to a single ground at the reference point of the application board to avoid fluctuations in the small-signal ground caused by large currents. Also ensure that the ground traces of external components do not cause variations on the ground voltage. The ground lines must be as short and thick as possible to reduce line impedance.

5. Thermal Consideration

Should by any chance the power dissipation rating be exceeded the rise in temperature of the chip may result in deterioration of the properties of the chip. In case of exceeding this absolute maximum rating, increase the board size and copper area to prevent exceeding the Pd rating.

6. Recommended Operating Conditions

These conditions represent a range within which the expected characteristics of the IC can be approximately obtained. The electrical characteristics are guaranteed under the conditions of each parameter.

7. Inrush Current

When power is first supplied to the IC, it is possible that the internal logic may be unstable and inrush current may flow instantaneously due to the internal powering sequence and delays, especially if the IC has more than one power supply. Therefore, give special consideration to power coupling capacitance, power wiring, width of ground wiring, and routing of connections.

8. Operation Under Strong Electromagnetic Field

Operating the IC in the presence of a strong electromagnetic field may cause the IC to malfunction.

9. Testing on Application Boards

When testing the IC on an application board, connecting a capacitor directly to a low-impedance output pin may subject the IC to stress. Always discharge capacitors completely after each process or step. The IC's power supply should always be turned off completely before connecting or removing it from the test setup during the inspection process. To prevent damage from static discharge, ground the IC during assembly and use similar precautions during transport and storage.

10. Inter-pin Short and Mounting Errors

Ensure that the direction and position are correct when mounting the IC on the PCB. Incorrect mounting may result in damaging the IC. Avoid nearby pins being shorted to each other especially to ground, power supply and output pin. Inter-pin shorts could be due to many reasons such as metal particles, water droplets (in very humid environment) and unintentional solder bridge deposited in between pins during assembly to name a few.

11. Unused Input Pins

Input pins of an IC are often connected to the gate of a MOS transistor. The gate has extremely high impedance and extremely low capacitance. If left unconnected, the electric field from the outside can easily charge it. The small charge acquired in this way is enough to produce a significant effect on the conduction through the transistor and cause unexpected operation of the IC. So unless otherwise specified, unused input pins should be connected to the power supply or ground line.

Operational Notes – continued

12. Regarding the Input Pin of the IC

This monolithic IC contains P+ isolation and P substrate layers between adjacent elements in order to keep them isolated. P-N junctions are formed at the intersection of the P layers with the N layers of other elements, creating a parasitic diode or transistor. For example (refer to figure below):

When $GND > Pin A$ and $GND > Pin B$, the P-N junction operates as a parasitic diode.
 When $GND > Pin B$, the P-N junction operates as a parasitic transistor.

Parasitic diodes inevitably occur in the structure of the IC. The operation of parasitic diodes can result in mutual interference among circuits, operational faults, or physical damage. Therefore, conditions that cause these diodes to operate, such as applying a voltage lower than the GND voltage to an input pin (and thus to the P substrate) should be avoided.

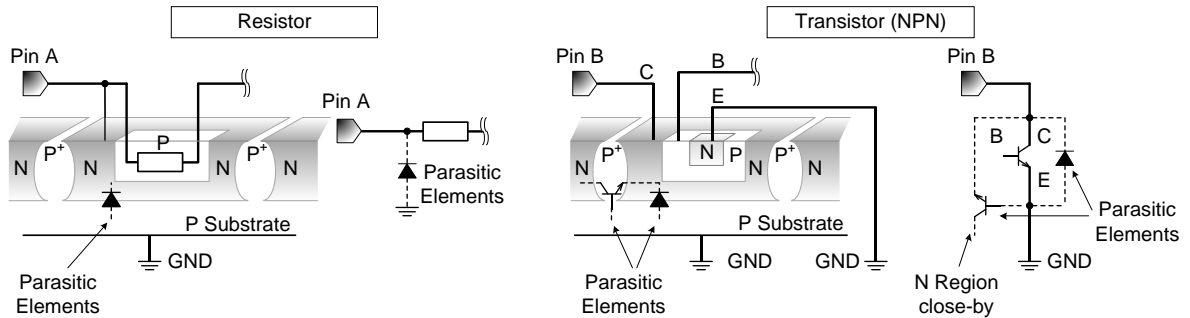

Figure 9.

Example of monolithic IC structure

13. Ceramic Capacitor

When using a ceramic capacitor, determine the dielectric constant considering the change of capacitance with temperature and the decrease in nominal capacitance due to DC bias and others.

14. Area of Safe Operation (ASO)

Operate the IC such that the output voltage, output current, and power dissipation are all within the Area of Safe Operation (ASO).

15. Thermal Shutdown Circuit(TSD)

This IC has a built-in thermal shutdown circuit that prevents heat damage to the IC. Normal operation should always be within the IC's power dissipation rating. If however the rating is exceeded for a continued period, the junction temperature (T_j) will rise which will activate the TSD circuit that will turn OFF all output pins. When the T_j falls below the TSD threshold, the circuits are automatically restored to normal operation.

Note that the TSD circuit operates in a situation that exceeds the absolute maximum ratings and therefore, under no circumstances, should the TSD circuit be used in a set design or for any purpose other than protecting the IC from heat damage.

16. Disturbance light

In a device where a portion of silicon is exposed to light such as in a WL-CSP, IC characteristics may be affected due to photoelectric effect. For this reason, it is recommended to come up with countermeasures that will prevent the chip from being exposed to light.

Ordering Information

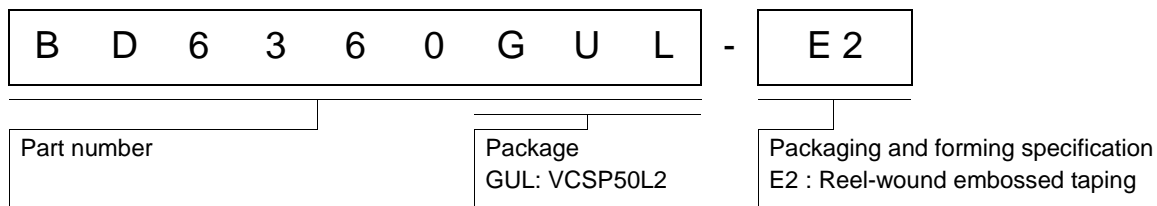

Marking Diagram

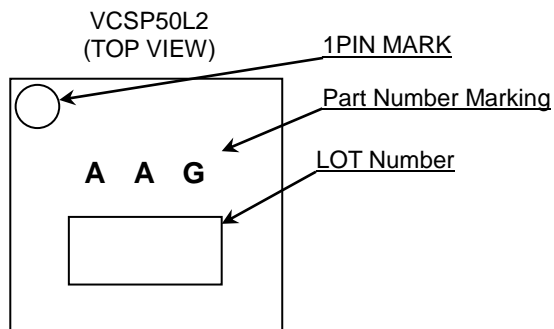

Part Number Marking	Package	Orderable Part Number
AAG	VCSP50L2	BD6360GUL-E2

Physical Dimension, Tape and Reel Information

Package Name	VCSP50L2 (BD6360GUL)
--------------	----------------------

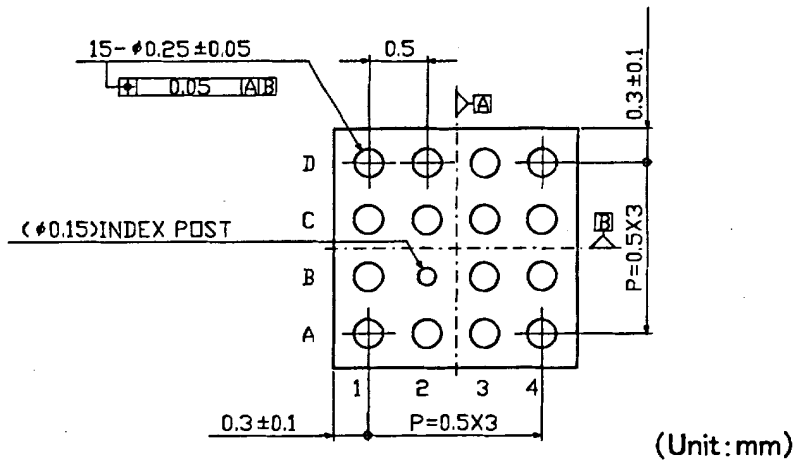
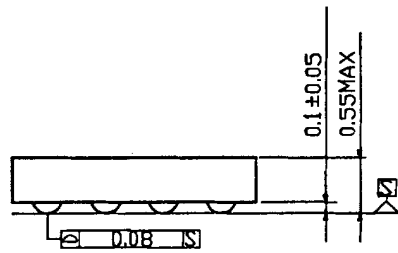
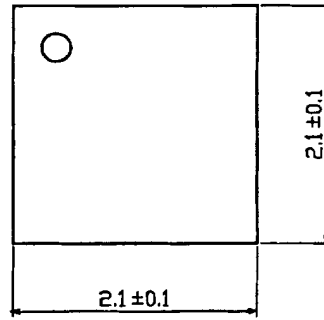

< Tape and Reel information >

Tape	Embossed carrier tape (with dry pack)
Quantity	3000pcs
Direction of feed	E2 (The direction is the 1pin of product is at the upper left when you hold reel on the left hand and you pull out the tape on the right hand.)

※When you order, please order in times the amount of package quantity.

Revision History

Date	Revision	Changes
09.Dec.2015	001	New Release

Notice

Precaution on using ROHM Products

- Our Products are designed and manufactured for application in ordinary electronic equipments (such as AV equipment, OA equipment, telecommunication equipment, home electronic appliances, amusement equipment, etc.). If you intend to use our Products in devices requiring extremely high reliability (such as medical equipment ^(Note 1), transport equipment, traffic equipment, aircraft/spacecraft, nuclear power controllers, fuel controllers, car equipment including car accessories, safety devices, etc.) and whose malfunction or failure may cause loss of human life, bodily injury or serious damage to property ("Specific Applications"), please consult with the ROHM sales representative in advance. Unless otherwise agreed in writing by ROHM in advance, ROHM shall not be in any way responsible or liable for any damages, expenses or losses incurred by you or third parties arising from the use of any ROHM's Products for Specific Applications.

(Note1) Medical Equipment Classification of the Specific Applications

JAPAN	USA	EU	CHINA
CLASS III	CLASS III	CLASS II b	CLASS III
CLASS IV		CLASS III	

- ROHM designs and manufactures its Products subject to strict quality control system. However, semiconductor products can fail or malfunction at a certain rate. Please be sure to implement, at your own responsibilities, adequate safety measures including but not limited to fail-safe design against the physical injury, damage to any property, which a failure or malfunction of our Products may cause. The following are examples of safety measures:
 - Installation of protection circuits or other protective devices to improve system safety
 - Installation of redundant circuits to reduce the impact of single or multiple circuit failure
- Our Products are designed and manufactured for use under standard conditions and not under any special or extraordinary environments or conditions, as exemplified below. Accordingly, ROHM shall not be in any way responsible or liable for any damages, expenses or losses arising from the use of any ROHM's Products under any special or extraordinary environments or conditions. If you intend to use our Products under any special or extraordinary environments or conditions (as exemplified below), your independent verification and confirmation of product performance, reliability, etc. prior to use, must be necessary:
 - Use of our Products in any types of liquid, including water, oils, chemicals, and organic solvents
 - Use of our Products outdoors or in places where the Products are exposed to direct sunlight or dust
 - Use of our Products in places where the Products are exposed to sea wind or corrosive gases, including Cl₂, H₂S, NH₃, SO₂, and NO₂
 - Use of our Products in places where the Products are exposed to static electricity or electromagnetic waves
 - Use of our Products in proximity to heat-producing components, plastic cords, or other flammable items
 - Sealing or coating our Products with resin or other coating materials
 - Use of our Products without cleaning residue of flux (even if you use no-clean type fluxes, cleaning residue of flux is recommended); or Washing our Products by using water or water-soluble cleaning agents for cleaning residue after soldering
 - Use of the Products in places subject to dew condensation
- The Products are not subject to radiation-proof design.
- Please verify and confirm characteristics of the final or mounted products in using the Products.
- In particular, if a transient load (a large amount of load applied in a short period of time, such as pulse. is applied, confirmation of performance characteristics after on-board mounting is strongly recommended. Avoid applying power exceeding normal rated power; exceeding the power rating under steady-state loading condition may negatively affect product performance and reliability.
- De-rate Power Dissipation depending on ambient temperature. When used in sealed area, confirm that it is the use in the range that does not exceed the maximum junction temperature.
- Confirm that operation temperature is within the specified range described in the product specification.
- ROHM shall not be in any way responsible or liable for failure induced under deviant condition from what is defined in this document.

Precaution for Mounting / Circuit board design

- When a highly active halogenous (chlorine, bromine, etc.) flux is used, the residue of flux may negatively affect product performance and reliability.
- In principle, the reflow soldering method must be used on a surface-mount products, the flow soldering method must be used on a through hole mount products. If the flow soldering method is preferred on a surface-mount products, please consult with the ROHM representative in advance.

For details, please refer to ROHM Mounting specification

Precautions Regarding Application Examples and External Circuits

1. If change is made to the constant of an external circuit, please allow a sufficient margin considering variations of the characteristics of the Products and external components, including transient characteristics, as well as static characteristics.
2. You agree that application notes, reference designs, and associated data and information contained in this document are presented only as guidance for Products use. Therefore, in case you use such information, you are solely responsible for it and you must exercise your own independent verification and judgment in the use of such information contained in this document. ROHM shall not be in any way responsible or liable for any damages, expenses or losses incurred by you or third parties arising from the use of such information.

Precaution for Electrostatic

This Product is electrostatic sensitive product, which may be damaged due to electrostatic discharge. Please take proper caution in your manufacturing process and storage so that voltage exceeding the Products maximum rating will not be applied to Products. Please take special care under dry condition (e.g. Grounding of human body / equipment / solder iron, isolation from charged objects, setting of Ionizer, friction prevention and temperature / humidity control).

Precaution for Storage / Transportation

1. Product performance and soldered connections may deteriorate if the Products are stored in the places where:
 - [a] the Products are exposed to sea winds or corrosive gases, including Cl₂, H₂S, NH₃, SO₂, and NO₂
 - [b] the temperature or humidity exceeds those recommended by ROHM
 - [c] the Products are exposed to direct sunshine or condensation
 - [d] the Products are exposed to high Electrostatic
2. Even under ROHM recommended storage condition, solderability of products out of recommended storage time period may be degraded. It is strongly recommended to confirm solderability before using Products of which storage time is exceeding the recommended storage time period.
3. Store / transport cartons in the correct direction, which is indicated on a carton with a symbol. Otherwise bent leads may occur due to excessive stress applied when dropping of a carton.
4. Use Products within the specified time after opening a humidity barrier bag. Baking is required before using Products of which storage time is exceeding the recommended storage time period.

Precaution for Product Label

QR code printed on ROHM Products label is for ROHM's internal use only.

Precaution for Disposition

When disposing Products please dispose them properly using an authorized industry waste company.

Precaution for Foreign Exchange and Foreign Trade act

Since concerned goods might be fallen under listed items of export control prescribed by Foreign exchange and Foreign trade act, please consult with ROHM in case of export.

Precaution Regarding Intellectual Property Rights

1. All information and data including but not limited to application example contained in this document is for reference only. ROHM does not warrant that foregoing information or data will not infringe any intellectual property rights or any other rights of any third party regarding such information or data.
2. ROHM shall not have any obligations where the claims, actions or demands arising from the combination of the Products with other articles such as components, circuits, systems or external equipment (including software).
3. No license, expressly or implied, is granted hereby under any intellectual property rights or other rights of ROHM or any third parties with respect to the Products or the information contained in this document. Provided, however, that ROHM will not assert its intellectual property rights or other rights against you or your customers to the extent necessary to manufacture or sell products containing the Products, subject to the terms and conditions herein.

Other Precaution



1. This document may not be reprinted or reproduced, in whole or in part, without prior written consent of ROHM.
2. The Products may not be disassembled, converted, modified, reproduced or otherwise changed without prior written consent of ROHM.
3. In no event shall you use in any way whatsoever the Products and the related technical information contained in the Products or this document for any military purposes, including but not limited to, the development of mass-destruction weapons.
4. The proper names of companies or products described in this document are trademarks or registered trademarks of ROHM, its affiliated companies or third parties.

General Precaution

1. Before you use our Products, you are requested to carefully read this document and fully understand its contents. ROHM shall not be in any way responsible or liable for failure, malfunction or accident arising from the use of any ROHM's Products against warning, caution or note contained in this document.
2. All information contained in this document is current as of the issuing date and subject to change without any prior notice. Before purchasing or using ROHM's Products, please confirm the latest information with a ROHM sales representative.
3. The information contained in this document is provided on an "as is" basis and ROHM does not warrant that all information contained in this document is accurate and/or error-free. ROHM shall not be in any way responsible or liable for any damages, expenses or losses incurred by you or third parties resulting from inaccuracy or errors of or concerning such information.

Looking for pricing, stock, or lifecycle information?

Click below to explore more details on WIN SOURCE:

-  [View BD6360GUL-E2 on WIN SOURCE](#)
-  [Rohm Semiconductor](#) Information

Optimize Your Supply Chain with WIN SOURCE Solutions

-  Global Sourcing Solution
-  Obsolete Management
-  Cost Control Management
-  Shortage Management
-  Alternative Solution
-  Excess Inventory Management