



**THE DATASHEET OF  
LMH6401IRMZT**



## LMH6401 DC to 4.5 GHz, Fully-Differential, Digital Variable-Gain Amplifier

### 1 Features

- 3-dB Bandwidth: 4.5 GHz at 26-dB Gain
- Gain Range: –6 dB to 26 dB in 1-dB Steps
- Differential Input Impedance: 100  $\Omega$
- Differential Output with Common-Mode Control
- Distortion at Max Gain ( $V_O = 2 V_{PPD}$ ,  $R_L = 200 \Omega$ ):
  - 200 MHz: HD2 at –73 dBc, HD3 at –80 dBc
  - 500 MHz: HD2 at –68 dBc, HD3 at –72 dBc
  - 1 GHz: HD2 at –63 dBc, HD3 at –63 dBc
  - 2 GHz: HD2 at –58 dBc, HD3 at –54 dBc
- Output IP3:
  - 43 dBm at 200 MHz
  - 33 dBm at 1 GHz
  - 27 dBm at 2 GHz
- Output IP2:
  - 67 dBm at 200 MHz
  - 60 dBm at 1 GHz
  - 52 dBm at 2 GHz
- 8-dB Noise Figure at 1 GHz,  $R_S = 100 \Omega$
- 82-ps Rise, Fall Time Pulse Response
- Supply Operation: 5.0 V at 69 mA
- Supports Single- and ( $\pm$ ) Split-Supply Operation:
  - DC- and AC-Coupled Applications
- Fabricated on an Advanced Complementary BiCMOS Process
- 3-mm x 3-mm UQFN-16 Package

### 2 Applications

- Test and Measurement
- Ultra-Wideband ADC Drivers
- Communications Receivers
- RF Sampling Subsystems
- SAW Filter Buffers and Drivers
- Defense and Radar

### 3 Description

The LMH6401 is a wideband, digitally-controlled, variable-gain amplifier (DVGA) designed for dc to radio frequency (RF), intermediate frequency (IF), and high-speed time-domain applications. The device is an ideal analog-to-digital converter (ADC) driver for dc- or ac-coupled applications that require an automatic gain control (AGC).

Noise and distortion performance is optimized to drive ultra-wideband ADCs. The amplifier has an 8-dB noise figure at maximum gain and a –63-dBc harmonic distortion at 1 GHz for full-scale signal levels. The device supports both single- and split-supply operation for driving an ADC. A common-mode reference input pin is provided to align the amplifier output common-mode with the ADC input requirements.

Gain control is performed via an SPI™ interface, allowing a 32-dB gain range from –6 dB to 26 dB in 1-dB steps. A power-down feature is also available through the external PD pin or SPI control.

This level of performance is achieved at a low power level of 345 mW. The operating ambient temperature range is –40°C to 85°C.

#### Device Information<sup>(1)</sup>

PART NUMBER	PACKAGE	BODY SIZE (NOM)
LMH6401	UQFN (16)	3.00 mm x 3.00 mm

(1) For all available packages, see the orderable addendum at the end of the data sheet.

#### Harmonic Distortion vs Frequency ( $V_O = 2 V_{PPD}$ )

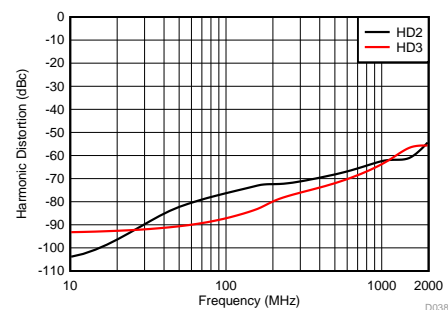

#### IF Sampling Receiver Application

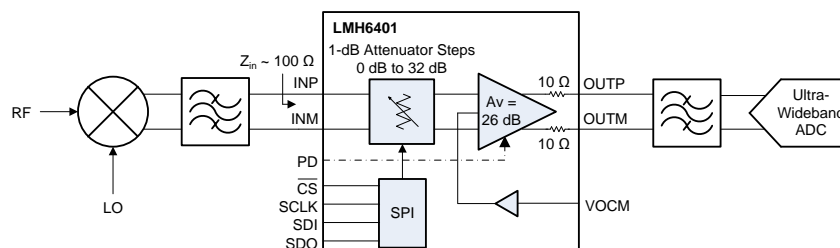

## Table of Contents

<b>1 Features</b> ..... 1 <b>2 Applications</b> ..... 1 <b>3 Description</b> ..... 1 <b>4 Revision History</b> ..... 2 <b>5 Device Options</b> ..... 3 <b>6 Pin Configuration and Functions</b> ..... 4 <b>7 Specifications</b> ..... 5 7.1 Absolute Maximum Ratings ..... 5 7.2 ESD Ratings ..... 5 7.3 Recommended Operating Conditions ..... 5 7.4 Thermal Information ..... 5 7.5 Electrical Characteristics ..... 6 7.6 SPI Timing Requirements ..... 8 7.7 Typical Characteristics ..... 9 <b>8 Parameter Measurement Information</b> ..... 16 8.1 Setup Diagrams ..... 16 8.2 Output Measurement Reference Points ..... 17 8.3 ATE Testing and DC Measurements ..... 17 8.4 Frequency Response ..... 17 8.5 Distortion ..... 17 8.6 Noise Figure ..... 18 8.7 Pulse Response, Slew Rate, and Overdrive Recovery ..... 18 8.8 Power Down ..... 18 8.9 VOVM Frequency Response ..... 18	<b>9 Detailed Description</b> ..... 19 9.1 Overview ..... 19 9.2 Functional Block Diagram ..... 19 9.3 Feature Description ..... 20 9.4 Device Functional Modes ..... 20 9.5 Programming ..... 20 9.6 Register Maps ..... 23 <b>10 Application and Implementation</b> ..... 26 10.1 Application Information ..... 26 10.2 Typical Application ..... 30 10.3 Do's and Don'ts ..... 35 <b>11 Power-Supply Recommendations</b> ..... 36 11.1 Single-Supply Operation ..... 36 11.2 Split-Supply Operation ..... 36 <b>12 Layout</b> ..... 37 12.1 Layout Guidelines ..... 37 12.2 Layout Examples ..... 38 <b>13 Device and Documentation Support</b> ..... 39 13.1 Documentation Support ..... 39 13.2 Community Resources ..... 39 13.3 Trademarks ..... 39 13.4 Electrostatic Discharge Caution ..... 39 13.5 Glossary ..... 39 <b>14 Mechanical, Packaging, and Orderable Information</b> ..... 40
---	--

## 4 Revision History

Changes from Original (April 2015) to Revision A	Page
• Released to production data .....	1

## 5 Device Options

**Table 1. FDA Device Companion**

DEVICE	BW ( $A_V = 12$ dB)	DISTORTION	NOISE
<a href="#">LMH5401</a>	6.2 GHz	-75-dBc HD2, -75-dBc HD3 at 500 MHz	1.25 nV/ $\sqrt{\text{Hz}}$
<a href="#">LMH3401</a>	7 GHz, G = 16 dB	-79-dBc HD2, -77-dBc HD3 at 500 MHz	1.4 nV/ $\sqrt{\text{Hz}}$
<a href="#">LMH6554</a>	1.6 GHz	-79-dBc HD2, -70-dBc HD3 at 250 MHz	0.9 nV/ $\sqrt{\text{Hz}}$

**Table 2. DVGA Device Comparison**

DEVICE	MAX GAIN, BW	DISTORTION	NOISE FIGURE
<a href="#">LMH6517</a>	22 dB, 1.2 GHz	43-dBm OIP3 at 200 MHz, -74-dBc HD3 at 200 MHz	5.5 dB
<a href="#">LMH6521</a>	26 dB, 1.2 GHz	49-dBm OIP3 at 200 MHz, -84-dBc HD3 at 200 MHz	7.3 dB
<a href="#">LMH6881</a>	26 dB, 2.4 GHz	42-dBm OIP3 at 200 MHz, -76-dBc HD3 at 200 MHz	9.7 dB

## 6 Pin Configuration and Functions

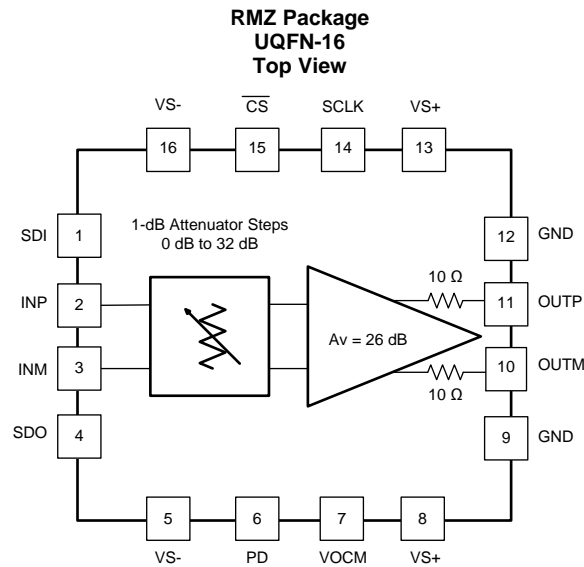

### Pin Functions

PIN		FUNCTION	DESCRIPTION
NO.	NAME		
1	SDI	Input	Serial interface input data
2	INP	Input	Positive input pin
3	INM	Input	Negative input pin
4	SDO	Output	Serial interface output data
5	VS-	Power	Negative supply voltage
6	PD	Input	Power-down pin. 0 = amplifier enabled, 1 = amplifier disabled
7	VOCM	Input	Input pin to set amplifier output common-mode voltage
8	VS+	Power	Positive supply voltage
9	GND	Power	Ground
10	OUTM	Output	Negative output pin
11	OUTP	Output	Positive output pin
12	GND	Power	Ground
13	VS+	Power	Positive supply voltage
14	SCLK	Input	Serial interface clock
15	CS	Input	Chip select
16	VS-	Power	Negative supply voltage

## 7 Specifications

### 7.1 Absolute Maximum Ratings

over operating free-air temperature range (unless otherwise noted)<sup>(1)</sup>

		MIN	MAX	UNIT
Supply voltage	$V = (VS+) - (VS-)$		5.5	V
Digital input pins		-0.3	VS+	V
Maximum input difference voltage			2.1	V
Maximum input voltage		VS-	VS+	V
Temperature	Maximum junction, $T_J$		150	°C
	Maximum junction, continuous operation, long-term reliability		125	°C
	Operating free-air, $T_A$	-40	85	°C
	Storage, $T_{stg}$	-65	150	°C

- (1) Stresses beyond those listed under *Absolute Maximum Ratings* may cause permanent damage to the device. These are stress ratings only, which do not imply functional operation of the device at these or any other conditions beyond those indicated under *Recommended Operating Conditions*. Exposure to absolute-maximum-rated conditions for extended periods may affect device reliability.

### 7.2 ESD Ratings

		VALUE	UNIT
$V_{(ESD)}$ Electrostatic discharge	Human-body model (HBM), per ANSI/ESDA/JEDEC JS-001 <sup>(1)</sup>	±2000	V
	Charged-device model (CDM), per JEDEC specification JESD22-C101 <sup>(2)</sup>	±1000	

- (1) JEDEC document JEP155 states that 500-V HBM allows safe manufacturing with a standard ESD control process.  
(2) JEDEC document JEP157 states that 250-V CDM allows safe manufacturing with a standard ESD control process.

### 7.3 Recommended Operating Conditions

over operating free-air temperature range (unless otherwise noted)

	MIN	NOM	MAX	UNIT
Supply voltage	4.0	5.0	5.25	V
Minimum operating positive (VS+) supply voltage	2.0			V
Ambient operating air temperature, $T_A$	-40	25	85	°C
Operating junction temperature, $T_J$	-40		125	°C

### 7.4 Thermal Information

THERMAL METRIC <sup>(1)</sup>		LMH6401	UNIT
		RMZ (UQFN)	
		16 PINS	
$R_{\theta JA}$	Junction-to-ambient thermal resistance	78	°C/W
$R_{\theta JC(top)}$	Junction-to-case (top) thermal resistance	43	°C/W
$R_{\theta JB}$	Junction-to-board thermal resistance	24	°C/W
$\Psi_{JT}$	Junction-to-top characterization parameter	2.3	°C/W
$\Psi_{JB}$	Junction-to-board characterization parameter	24	°C/W
$R_{\theta JC(bot)}$	Junction-to-case (bottom) thermal resistance	n/a	°C/W

- (1) For more information about traditional and new thermal metrics, see the *IC Package Thermal Metrics* application report, [SPRA953](#).

## 7.5 Electrical Characteristics

At  $T_A = 25^\circ\text{C}$ ,  $V_{S-} = -2.5\text{ V}$ ,  $V_{S+} = 2.5\text{ V}$ ,  $V_{OCM} = 0\text{ V}$ ,  $R_{LOAD} = 200\text{-}\Omega$  differential ( $R_{O(internal, diff)} = 20\ \Omega$ ),  $V_O = 2\text{ V}_{PPD}$ , and  $A_V = 26\text{ dB}$ , unless otherwise noted.

PARAMETER		TEST CONDITIONS	MIN	TYP	MAX	UNIT	TEST LEVEL <sup>(1)</sup>
<b>DYNAMIC PERFORMANCE</b>							
SSBW	Small-signal, -3-dB bandwidth	$A_V = 26\text{ dB}$ , $V_O = 200\text{ mV}_{PPD}$		4.5		GHz	C
LSBW	Large-signal, -3-dB bandwidth	$A_V = 26\text{ dB}$ , $V_O = 2.0\text{ V}_{PPD}$		4.5		GHz	C
	Bandwidth for 0.1-dB flatness	$A_V = 26\text{ dB}$ , $V_O = 2.0\text{ V}_{PPD}$		500		MHz	C
SR	Slew rate	$V_O = 2\text{-V step}$		18200		V/ $\mu\text{s}$	C
$t_{R, t_F}$	Rise and fall time	$V_O = 2\text{-V step}$ , 10% to 90%		82		ps	C
	Overdrive recovery	Overdrive = $\pm 0.5\text{ V}$		600		ps	C
	Output balance error	$f = 1\text{ GHz}$		-47		dB	C
$t_s$	Settling time to 1%	$V_O = 2\text{-V step}$ , $R_L = 200\ \Omega$		700		ps	C
HD2	Second-harmonic distortion	$f = 200\text{ MHz}$ , $V_O = 2.0\text{ V}_{PPD}$		-73		dBc	C
		$f = 500\text{ MHz}$ , $V_O = 2.0\text{ V}_{PPD}$		-68		dBc	C
		$f = 1\text{ GHz}$ , $V_O = 2.0\text{ V}_{PPD}$		-63		dBc	C
		$f = 2\text{ GHz}$ , $V_O = 2.0\text{ V}_{PPD}$		-58		dBc	C
HD3	Third-harmonic distortion	$f = 200\text{ MHz}$ , $V_O = 2.0\text{ V}_{PPD}$		-80		dBc	C
		$f = 500\text{ MHz}$ , $V_O = 2.0\text{ V}_{PPD}$		-72		dBc	C
		$f = 1\text{ GHz}$ , $V_O = 2.0\text{ V}_{PPD}$		-63		dBc	C
		$f = 2\text{ GHz}$ , $V_O = 2.0\text{ V}_{PPD}$		-54		dBc	C
OIP2	Output second-order intercept point	$f = 200\text{ MHz}$ , $P_O = -2\text{ dBm per tone}$		67		dBm	C
		$f = 500\text{ MHz}$ , $P_O = -2\text{ dBm per tone}$		65		dBm	C
		$f = 1\text{ GHz}$ , $P_O = -2\text{ dBm per tone}$		60		dBm	C
		$f = 2\text{ GHz}$ , $P_O = -2\text{ dBm per tone}$		52		dBm	C
OIP3	Output third-order intercept point	$f = 200\text{ MHz}$ , $P_O = -2\text{ dBm per tone}$		43		dBm	C
		$f = 500\text{ MHz}$ , $P_O = -2\text{ dBm per tone}$		40		dBm	C
		$f = 1\text{ GHz}$ , $P_O = -2\text{ dBm per tone}$		33		dBm	C
		$f = 2\text{ GHz}$ , $P_O = -2\text{ dBm per tone}$		27		dBm	C
IMD2	Second-order intermodulation distortion	$f = 500\text{ MHz}$ , $V_O = 1.0\text{ V}_{PP}$ per tone		-68		dBc	C
IMD3	Third-order intermodulation distortion	$f = 500\text{ MHz}$ , $V_O = 1.0\text{ V}_{PP}$ per tone		-83		dBc	C
P1dB	1-dB compression point	$f = 500\text{ MHz}$ , power measured at amplifier output		18.3		dBm	C
NF	Noise figure	$R_S = 100\ \Omega$	$f = 200\text{ MHz}$	7.7		dB	C
			$f = 1\text{ GHz}$	8		dB	C
	Output-referred noise voltage	$A_V = 26\text{ dB}$ , $f > 1\text{ MHz}$		30.4		nV/ $\sqrt{\text{Hz}}$	C
S12	Reverse transmission (S12)	$f = 1\text{ GHz}$		-65		dB	C
S11	Input return loss (S11)	100- $\Omega$ system, $f = 2\text{ GHz}$		-15		dB	C
<b>GAIN PARAMETERS</b>							
	Maximum voltage gain		25.5	26.0	26.5	dB	A
	Minimum voltage gain		-7.5	-6.0	-4.5	dB	A
	Gain range			32		dB	C
	Gain step size		0.9	1	1.1	dB	A
	Cumulative gain error	$A_V = 26\text{ dB to }10\text{ dB}$ (referenced to 26-dB gain)	-0.5		0.5	dB	A
		$A_V = 26\text{ dB to }-6\text{ dB}$ (referenced to 26-dB gain)	-1		1	dB	A
	Gain step transition time			1		ns	C

(1) Test levels: (A) 100% DC tested at  $25^\circ\text{C}$  unless otherwise specified. Over-temperature limits by characterization and simulation. (B) Limits set by bench verification and simulation. (C) Typical value only for information.

## Electrical Characteristics (continued)

At  $T_A = 25^\circ\text{C}$ ,  $V_{S-} = -2.5\text{ V}$ ,  $V_{S+} = 2.5\text{ V}$ ,  $V_{OCM} = 0\text{ V}$ ,  $R_{LOAD} = 200\text{-}\Omega$  differential ( $R_{o(\text{internal, diff})} = 20\text{ }\Omega$ ),  $V_O = 2 V_{PPD}$ , and  $A_V = 26\text{ dB}$ , unless otherwise noted.

PARAMETER		TEST CONDITIONS	MIN	TYP	MAX	UNIT	TEST LEVEL <sup>(1)</sup>
<b>ANALOG INPUT CHARACTERISTICS</b>							
$R_i$	Input resistance	Differential	85	100	112	$\Omega$	A
$C_i$	Input capacitance	Differential		0.8		pF	C
$V_{ICM}$	Input common-mode voltage	Self-biased to mid-supply	-0.3		0.3	V	A
$V_{ICLR}$	Low-level input common-mode voltage range	Differential gain shift < 1 dB		$(V_{S-}) + 1.5$		V	C
$V_{ICHR}$	High-level input common-mode voltage range	Differential gain shift < 1 dB		$(V_{S+}) - 1.5$		V	C
<b>ANALOG OUTPUT CHARACTERISTICS</b>							
$R_o$	Output resistance	Differential	18	20	25	$\Omega$	A
$V_{OL}$	Low-level output voltage range	Low-level clipping level		$(V_{S-}) + 1$	$(V_{S-}) + 1.1$	V	A
$V_{OH}$	High-level output voltage range	High-level clipping level	$(V_{S+}) - 1.1$	$(V_{S+}) - 1$		V	A
$V_{OM}$	Maximum output voltage swing	Differential		6.0		$V_{PPD}$	C
CMRR	Common-mode rejection ratio	$\pm 0.3\text{-V}$ input common-mode shift	38.4	45		dB	A
<b>POWER SUPPLY</b>							
$V_S$	Supply voltage [ $V = (V_{S+}) - (V_{S-})$ ]		4.0	5.0	5.25	V	A
	Minimum positive ( $V_{S+}$ ) supply voltage		2.0			V	A
PSRR	Power-supply rejection ratio	$V_{S-}$ , measured at 1-kHz sine-wave	66	70		dB	A
		$V_{S+}$ , measured at 1-kHz sine-wave	66	70		dB	A
$I_Q$	Quiescent current	PD = 0 (device enabled)	60	69	78	mA	A
		PD = 1 (device disabled)	1	7	12	mA	A
<b>OUTPUT COMMON-MODE CONTROL (VOCM Pin)</b>							
SSBW	Small-signal bandwidth	$V_{OCM} = 200\text{ mV}_{PP}$		160		MHz	C
	VOCM voltage range low	VOCM gain < 2%	-0.5			V	A
	VOCM voltage range high	VOCM gain < 2%			0.5	V	A
$V_{OO}$	Output offset voltage	All gain settings	-40		40	mV	A
		VOCM gain		1.0		V	C
$V_{OCM}$	Common-mode offset voltage	VOCM pin driven to GND	-10		10	mV	A
<b>POWER DOWN (PD Pin)</b>							
	Power-down quiescent current		1	7	12	mA	A
	PD bias current	PD = 2.5 V		80	100	$\mu\text{A}$	A
	Turn-on time delay	Time to $V_O = 90\%$ of final value		70		ns	C
	Turn-off time delay	Time to $V_O = 10\%$ of original value		10		ns	C
<b>DIGITAL INPUT/OUTPUT</b>							
$V_{IH}$	High-level input voltage	Referred to GND	1.2		$V_{S+}$	V	A
$V_{IL}$	Low-level input voltage	Referred to GND			0.8	V	A
$V_{OH}$	High-level output voltage	1 k $\Omega$ to GND	1.4			V	A
$V_{OL}$	Low-level output voltage	1 k $\Omega$ to GND			0.4	V	A

## 7.6 SPI Timing Requirements<sup>(1)</sup>

At  $T_A = 25^\circ\text{C}$ ,  $V_{S-} = -2.5\text{ V}$ ,  $V_{S+} = 2.5\text{ V}$ ,  $V_{OCM} = 0\text{ V}$ ,  $R_{LOAD} = 200\text{-}\Omega$  differential ( $R_{o(\text{internal, diff})} = 20\ \Omega$ ),  $V_O = 2\text{ V}_{PPD}$ , and  $A_V = 26\text{ dB}$ , unless otherwise noted. Limits set by bench verification and simulation.

		MIN	NOM	MAX	UNIT
$f_{s\_c}$	SCLK frequency			50	MHz
$t_{PH}$	SCLK pulse duration, high	10			ns
$t_{PL}$	SCLK pulse duration, low	10			ns
$t_{SU}$	SDI setup	3			ns
$t_H$	SDO hold	3			ns
$t_{IZ}$	SDO tri-state			3	ns
$t_{ODZ}$	SDO driven to tri-state <sup>(2)</sup>			5	ns
$t_{OZD}$	SDO tri-state to driven			3	ns
$t_{OD}$	SDO output delay <sup>(2)</sup>			3	ns
$t_{CSS}$	$\overline{CS}$ setup <sup>(3)</sup>	3			ns
$t_{CSH}$	$\overline{CS}$ hold	3			ns
$t_{IAG}$	Inter-access gap	20			ns

- (1) Ensured by design.  
 (2) Reference to negative edge of SCLK.  
 (3) Reference to positive edge of SCLK.

### 7.7 Typical Characteristics

At  $T_A = 25^\circ\text{C}$ ,  $V_{S-} = -2.5\text{ V}$ ,  $V_{S+} = 2.5\text{ V}$ ,  $V_{OCM} = 0\text{ V}$ ,  $R_{LOAD} = 200\text{-}\Omega$  differential ( $R_{o(internal, diff)} = 20\ \Omega$ ),  $V_O = 2\text{ V}_{PPD}$ , and  $A_V = 26\text{ dB}$ , unless otherwise noted. Differential input and output, and input and output pins referenced to mid-supply, unless otherwise noted. Measured using an EVM as discussed in the [Parameter Measurement Information](#) section.

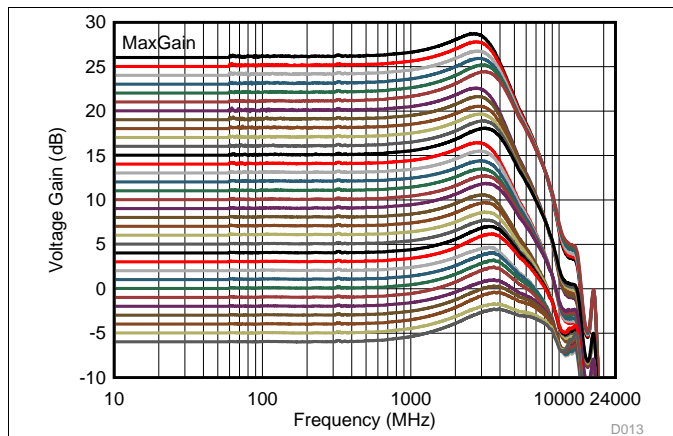

Figure 1. Voltage Gain vs Frequency (1-dB Gain Steps)

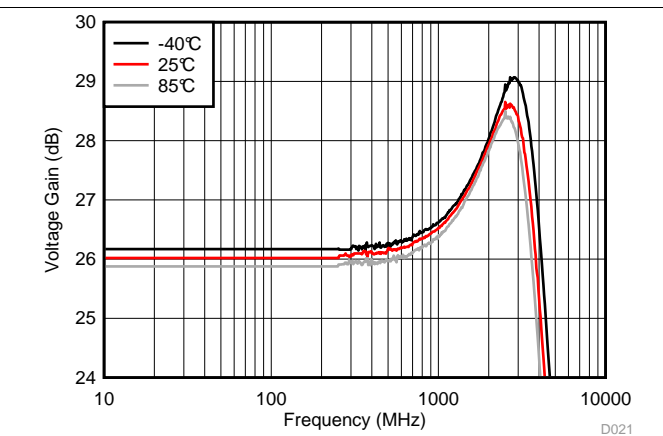

Figure 2. Maximum Gain vs Temperature

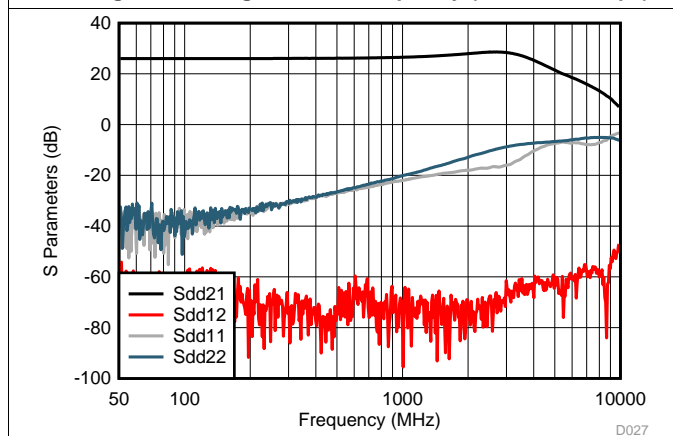

Figure 3. S-Parameters vs Frequency

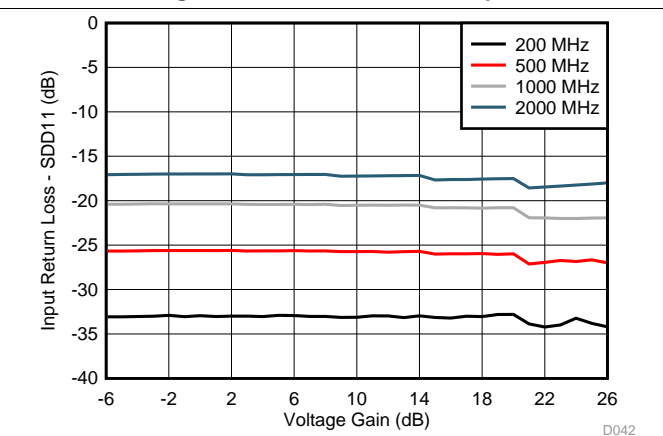

Figure 4. Input Return Loss vs Gain Settings

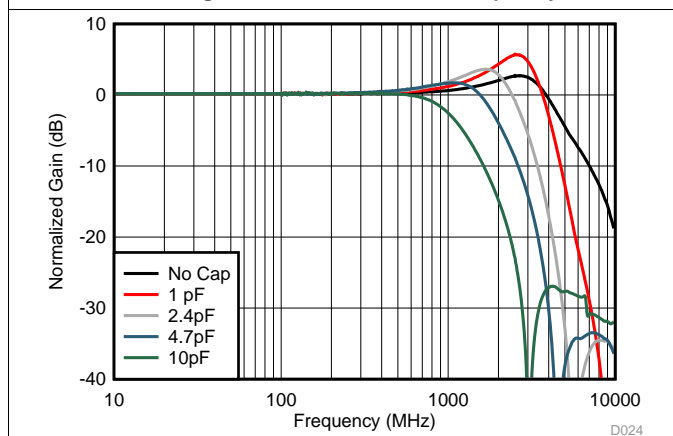

Figure 5. Frequency Response vs Capacitive Load

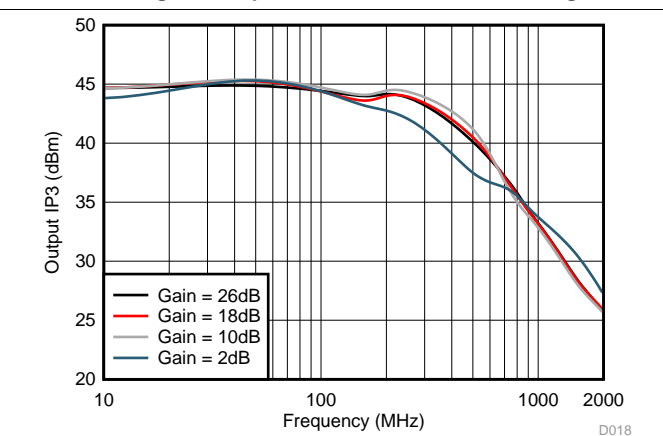

Figure 6. Output IP3 vs Frequency and Gain Settings

$P_O = -2\text{ dBm}$  per tone

Typical Characteristics (continued)

At  $T_A = 25^\circ\text{C}$ ,  $V_{S-} = -2.5\text{ V}$ ,  $V_{S+} = 2.5\text{ V}$ ,  $V_{OCM} = 0\text{ V}$ ,  $R_{LOAD} = 200\text{-}\Omega$  differential ( $R_{o(internal, diff)} = 20\text{ }\Omega$ ),  $V_O = 2\text{ V}_{PPD}$ , and  $A_V = 26\text{ dB}$ , unless otherwise noted. Differential input and output, and input and output pins referenced to mid-supply, unless otherwise noted. Measured using an EVM as discussed in the [Parameter Measurement Information](#) section.

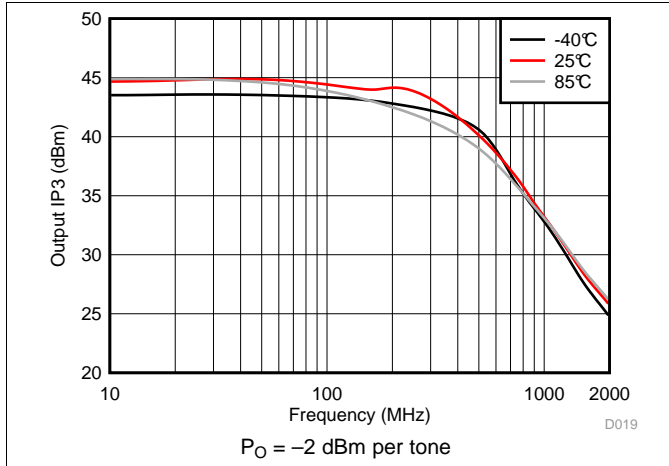

Figure 7. Output IP3 vs Frequency and Temperature

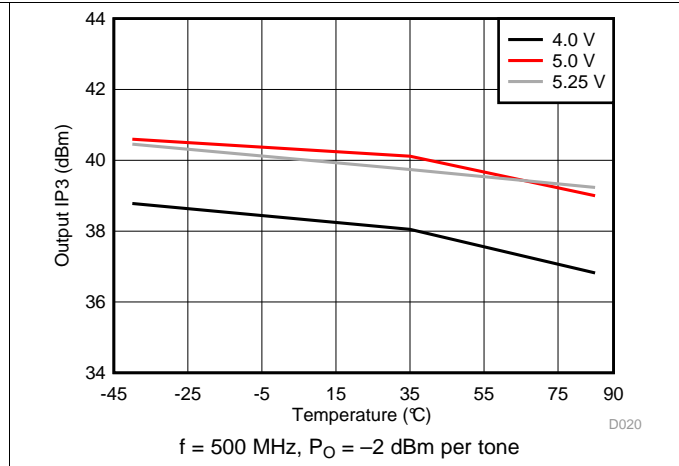

Figure 8. Output IP3 vs Supply Voltage and Temperature

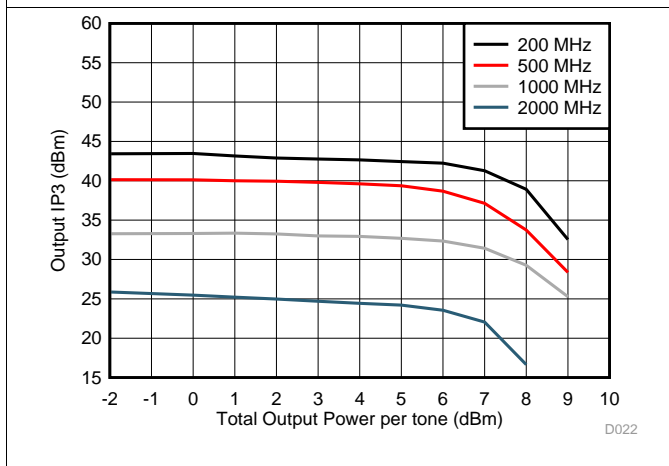

Figure 9. Output IP3 vs Total Output Power per Tone

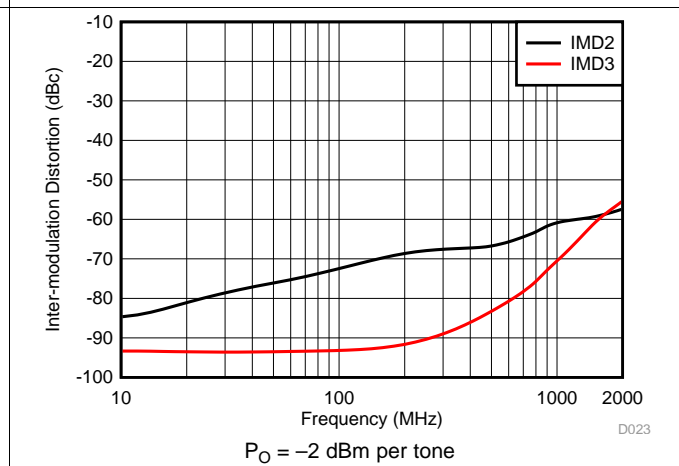

Figure 10. Intermodulation Distortion vs Frequency

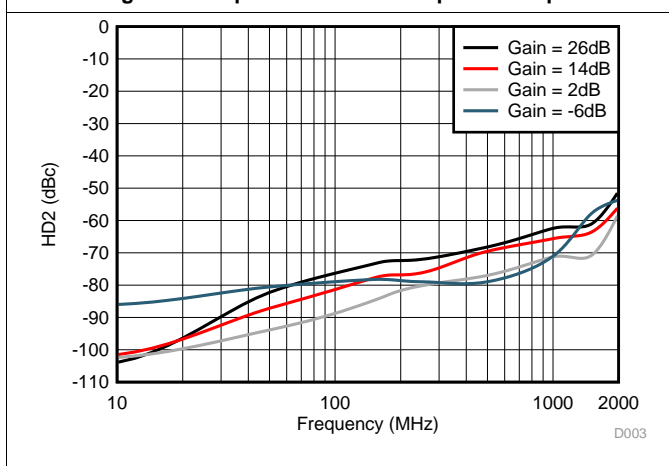

Figure 11. Second-Order Harmonic Distortion vs Frequency

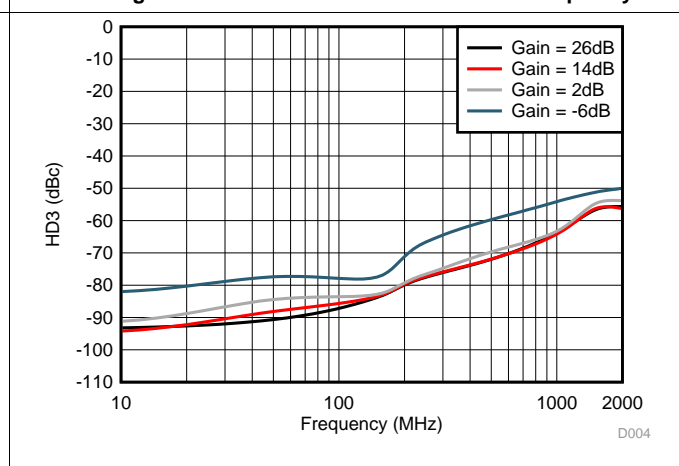

Figure 12. Third-Order Harmonic Distortion vs Frequency

Typical Characteristics (continued)

At  $T_A = 25^\circ\text{C}$ ,  $V_{S-} = -2.5\text{ V}$ ,  $V_{S+} = 2.5\text{ V}$ ,  $V_{OCM} = 0\text{ V}$ ,  $R_{LOAD} = 200\text{-}\Omega$  differential ( $R_{o(internal, diff)} = 20\text{ }\Omega$ ),  $V_O = 2\text{ V}_{PPD}$ , and  $A_V = 26\text{ dB}$ , unless otherwise noted. Differential input and output, and input and output pins referenced to mid-supply, unless otherwise noted. Measured using an EVM as discussed in the [Parameter Measurement Information](#) section.

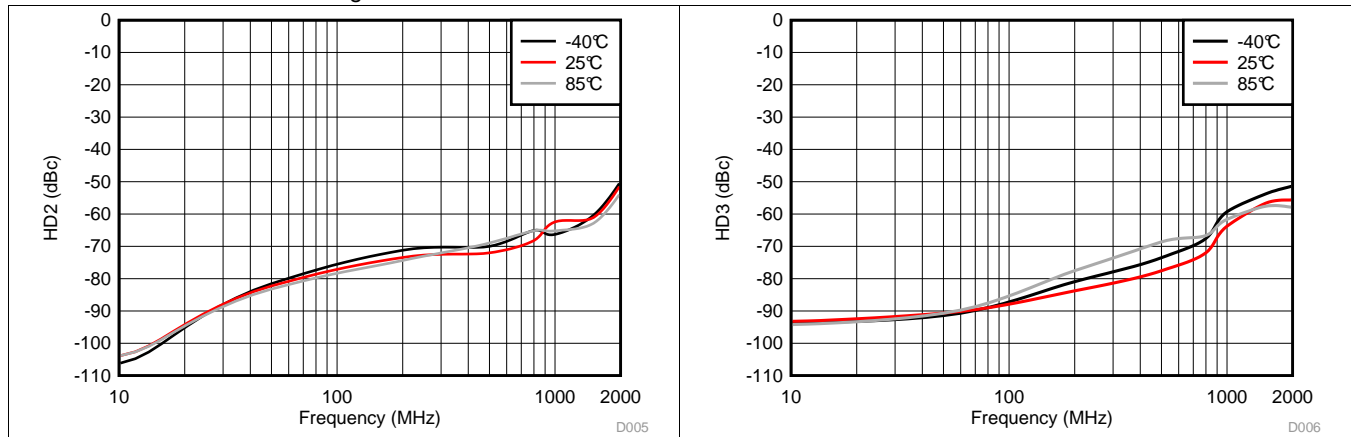

Figure 13. Second-Order Harmonic Distortion vs Frequency

Figure 14. Third-Order Harmonic Distortion vs Frequency

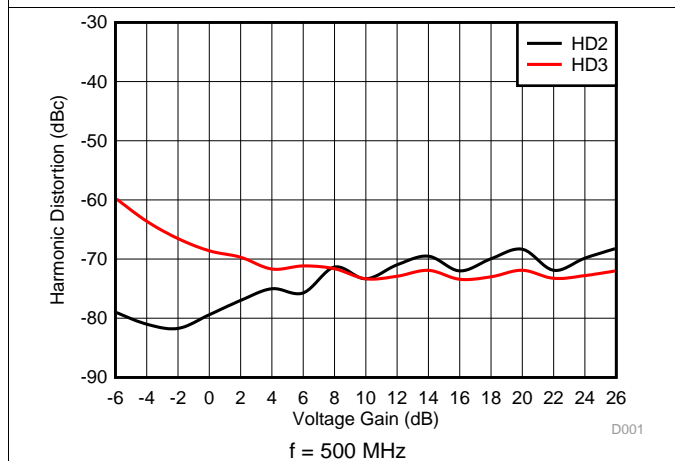

Figure 15. Harmonic Distortion vs Gain Settings

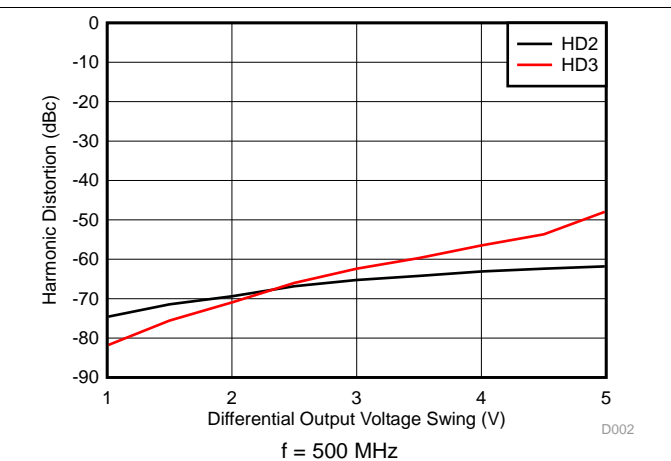

Figure 16. Harmonic Distortion vs Differential  $V_{PP}$

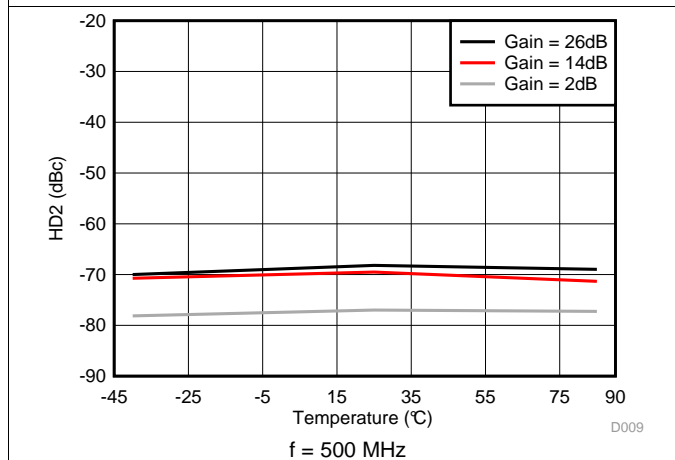

Figure 17. Second-Order Harmonic Distortion vs Temperature

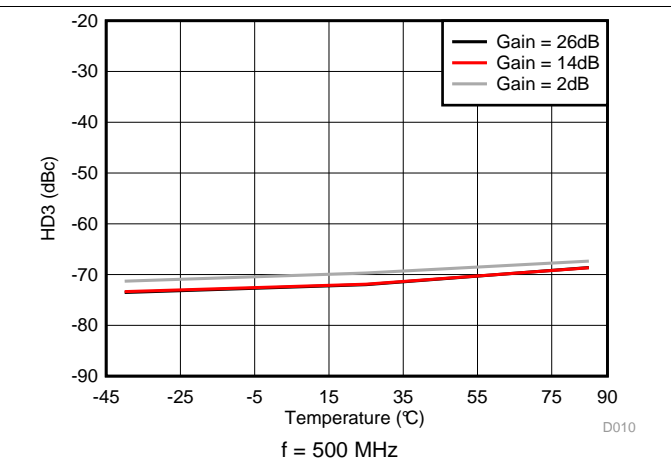

Figure 18. Third-Order Harmonic Distortion vs Temperature

### Typical Characteristics (continued)

At  $T_A = 25^\circ\text{C}$ ,  $V_{S-} = -2.5\text{ V}$ ,  $V_{S+} = 2.5\text{ V}$ ,  $V_{OCM} = 0\text{ V}$ ,  $R_{LOAD} = 200\text{-}\Omega$  differential ( $R_{o(internal, diff)} = 20\text{ }\Omega$ ),  $V_O = 2\text{ V}_{PPD}$ , and  $A_V = 26\text{ dB}$ , unless otherwise noted. Differential input and output, and input and output pins referenced to mid-supply, unless otherwise noted. Measured using an EVM as discussed in the [Parameter Measurement Information](#) section.

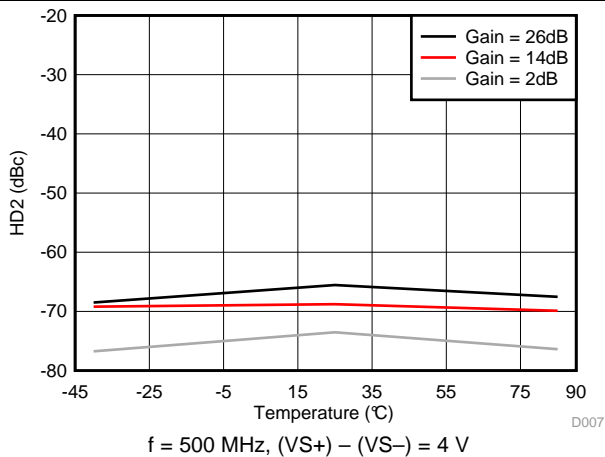

Figure 19. Second-Order Harmonic Distortion vs Temperature

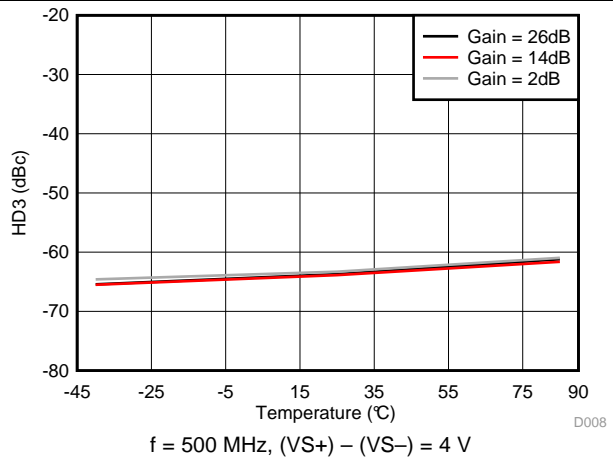

Figure 20. Third-Order Harmonic Distortion vs Temperature

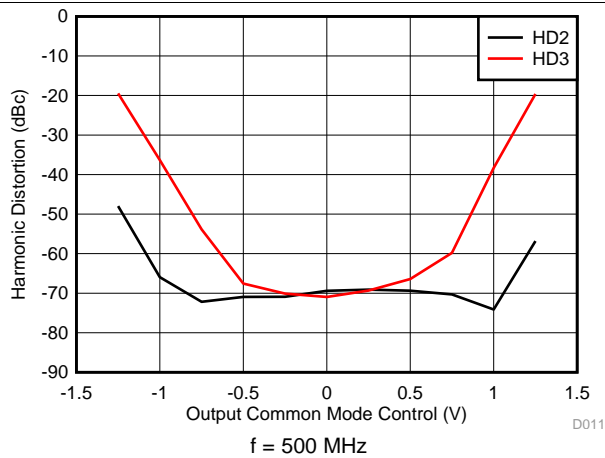

Figure 21. Harmonic Distortion vs Output Common-Mode Voltage

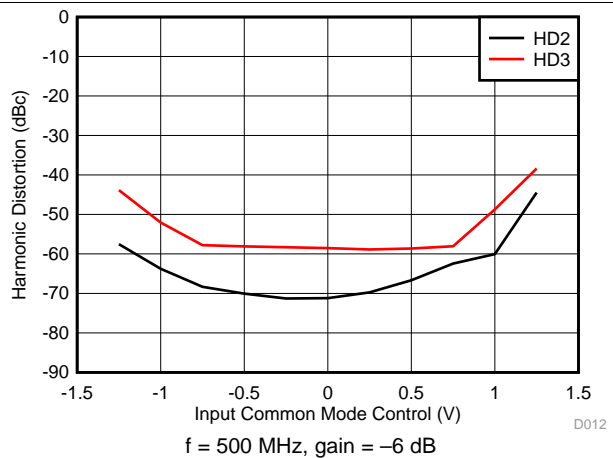

Figure 22. Harmonic Distortion vs Input CM Voltage

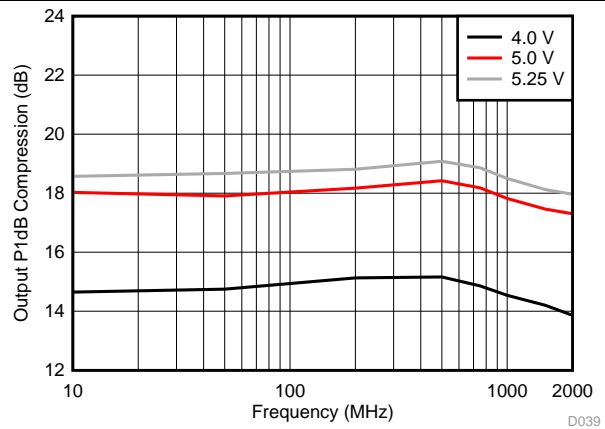

Figure 23. Output P1dB vs Frequency

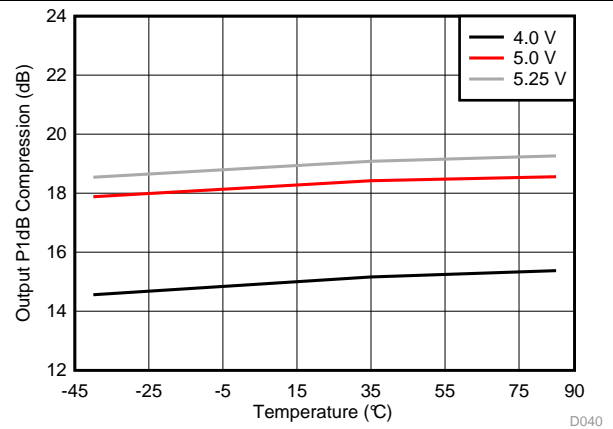
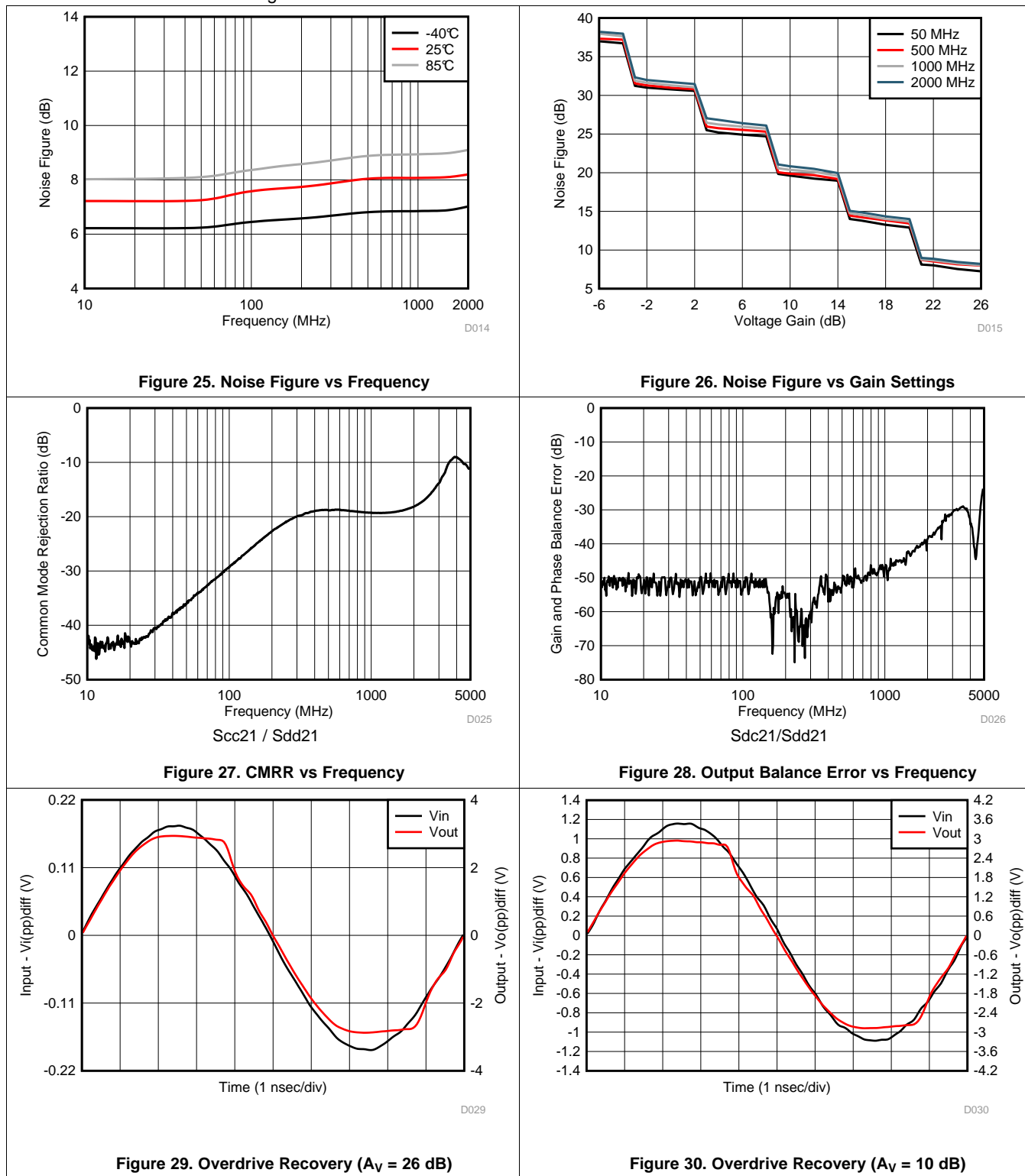

Figure 24. Output P1dB vs Temperature

Typical Characteristics (continued)

At  $T_A = 25^\circ\text{C}$ ,  $V_{S-} = -2.5\text{ V}$ ,  $V_{S+} = 2.5\text{ V}$ ,  $V_{OCM} = 0\text{ V}$ ,  $R_{LOAD} = 200\text{-}\Omega$  differential ( $R_{o(internal, diff)} = 20\text{ }\Omega$ ),  $V_O = 2\text{ V}_{PPD}$ , and  $A_V = 26\text{ dB}$ , unless otherwise noted. Differential input and output, and input and output pins referenced to mid-supply, unless otherwise noted. Measured using an EVM as discussed in the [Parameter Measurement Information](#) section.



### Typical Characteristics (continued)

At  $T_A = 25^\circ\text{C}$ ,  $V_{S-} = -2.5\text{ V}$ ,  $V_{S+} = 2.5\text{ V}$ ,  $V_{OCM} = 0\text{ V}$ ,  $R_{LOAD} = 200\text{-}\Omega$  differential ( $R_{o(internal, diff)} = 20\text{ }\Omega$ ),  $V_O = 2\text{ V}_{PPD}$ , and  $A_V = 26\text{ dB}$ , unless otherwise noted. Differential input and output, and input and output pins referenced to mid-supply, unless otherwise noted. Measured using an EVM as discussed in the [Parameter Measurement Information](#) section.

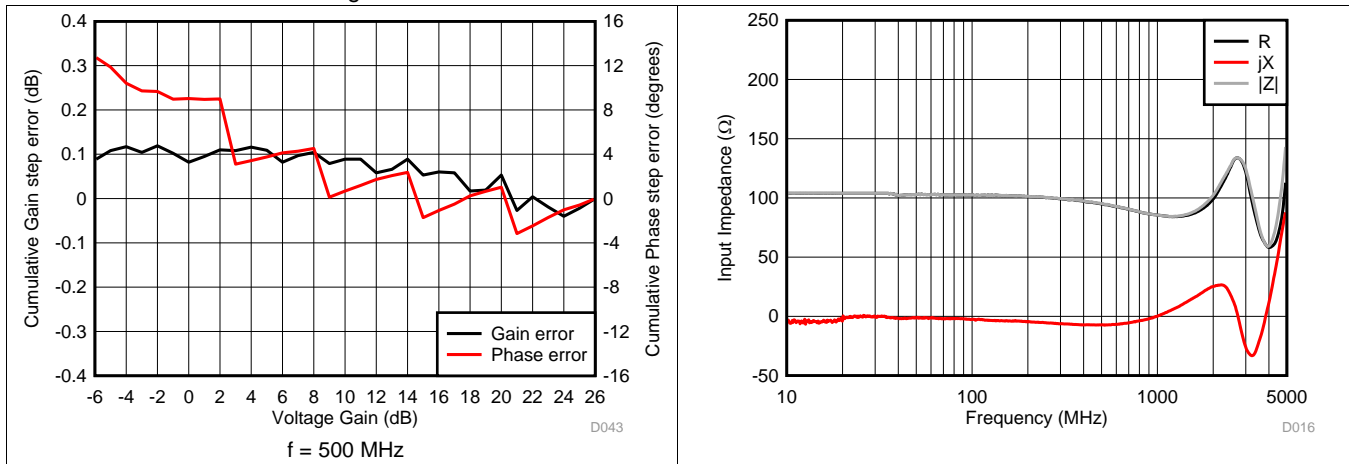

Figure 31. Cumulative Gain and Phase Step Error vs Gain Settings

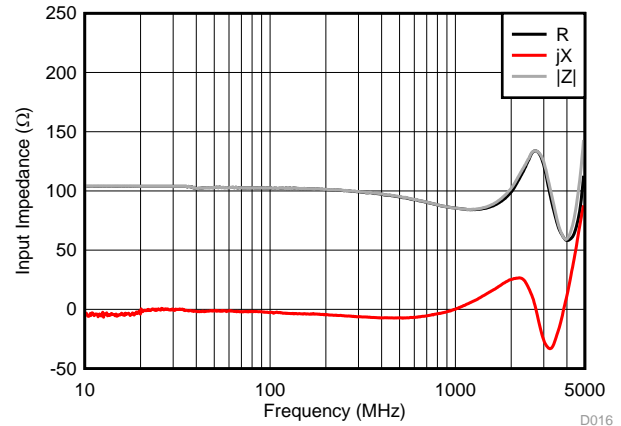

Figure 32. Input Impedance vs Frequency

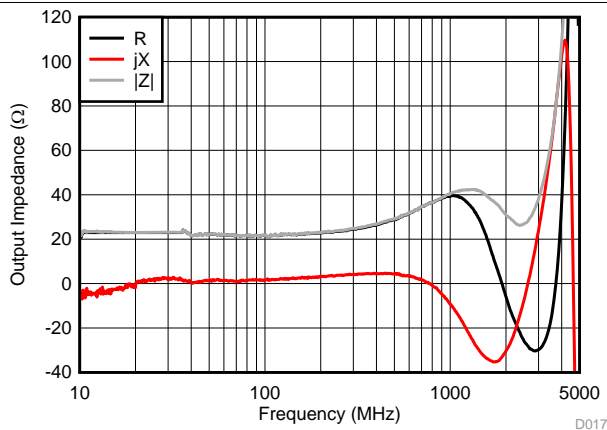

Figure 33. Output Impedance vs Frequency

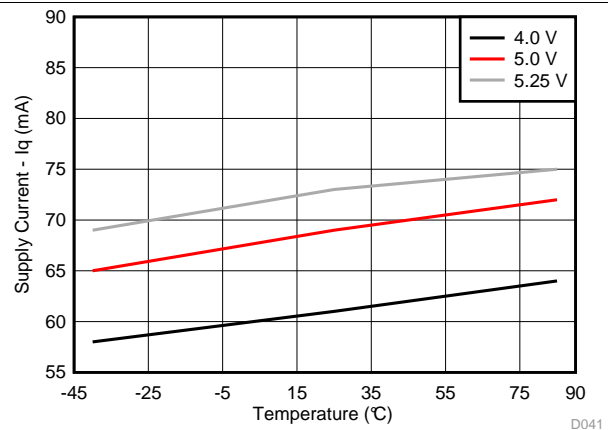

Figure 34. Supply Current vs Temperature

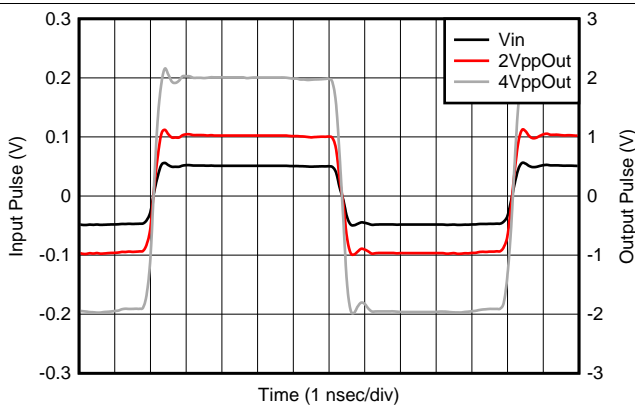

Figure 35. Output Step Response

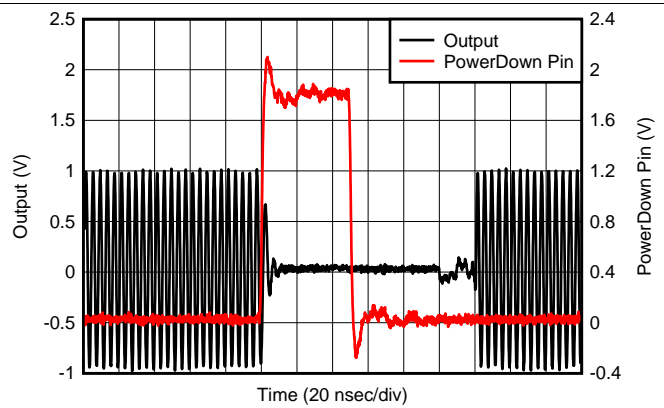
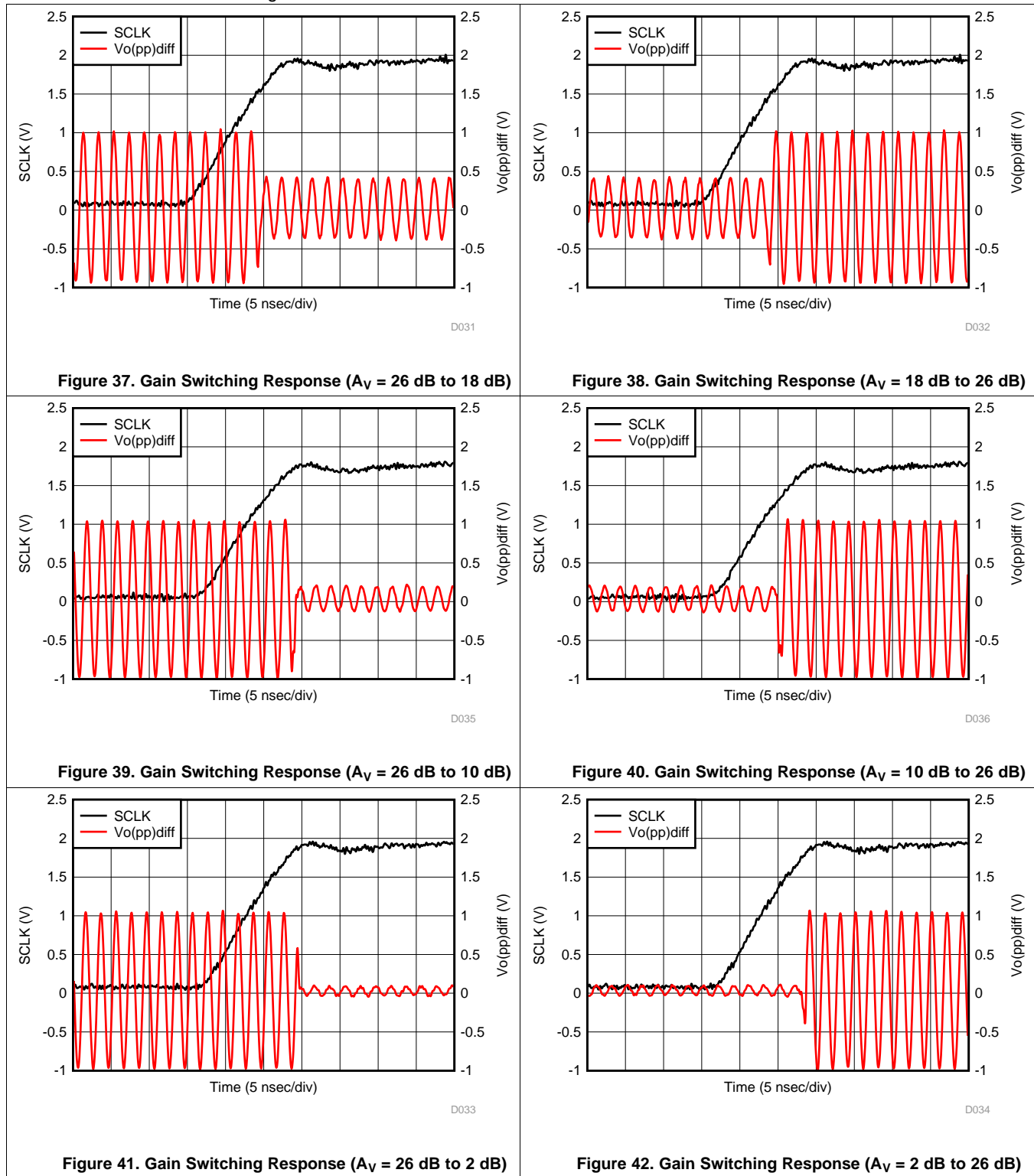

Figure 36. Power-Down Transition Response

Typical Characteristics (continued)

At  $T_A = 25^\circ\text{C}$ ,  $V_{S-} = -2.5\text{ V}$ ,  $V_{S+} = 2.5\text{ V}$ ,  $V_{OCM} = 0\text{ V}$ ,  $R_{LOAD} = 200\text{-}\Omega$  differential ( $R_{o(internal, diff)} = 20\text{ }\Omega$ ),  $V_O = 2\text{ V}_{PPD}$ , and  $A_V = 26\text{ dB}$ , unless otherwise noted. Differential input and output, and input and output pins referenced to mid-supply, unless otherwise noted. Measured using an EVM as discussed in the [Parameter Measurement Information](#) section.



## 8 Parameter Measurement Information

### 8.1 Setup Diagrams

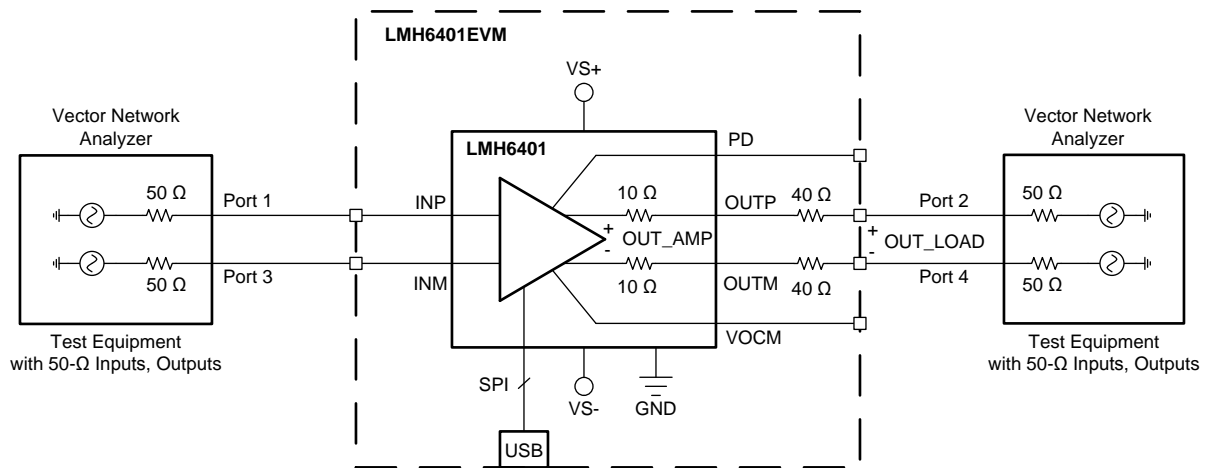

Figure 43. Frequency Response Differential Test Setup

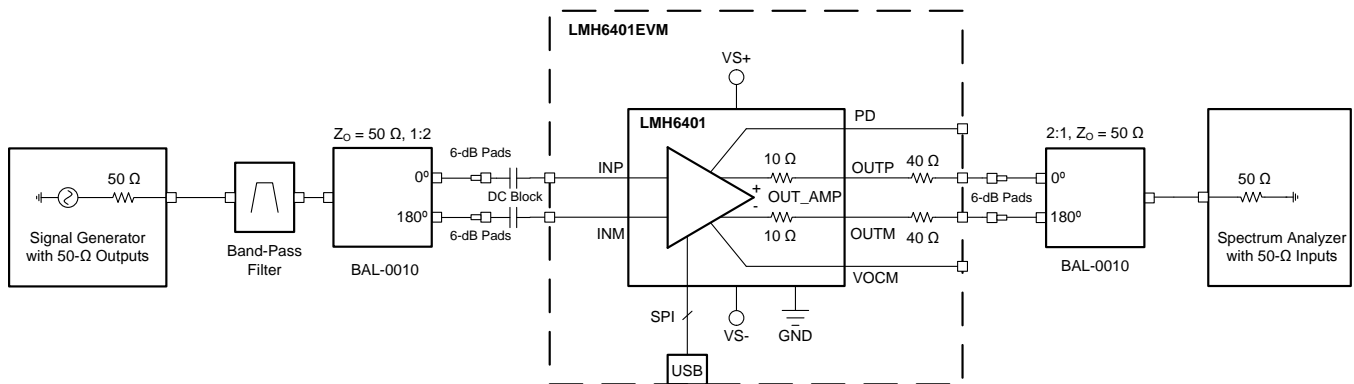

Figure 44. Single-Tone Harmonic Distortion Test Setup

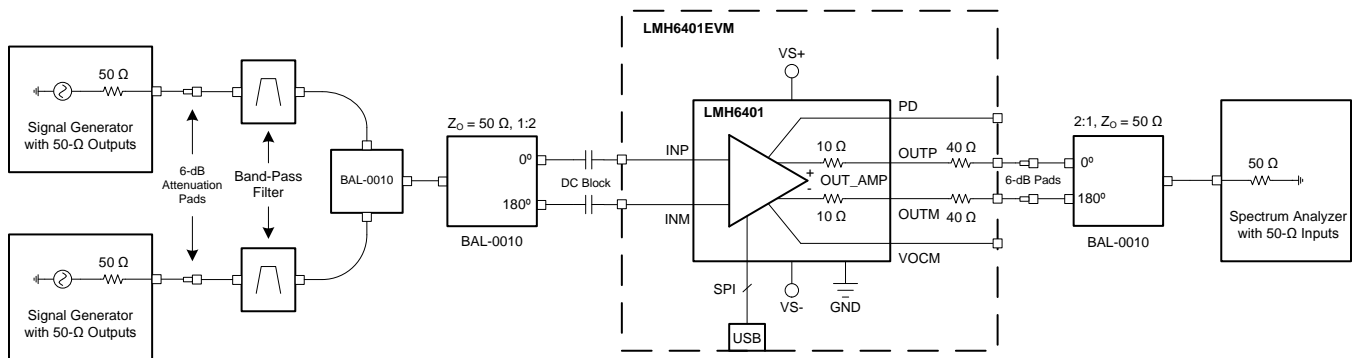

Figure 45. Two-Tone Linearity Test Setup (OIP3, OIP2)

## Setup Diagrams (continued)

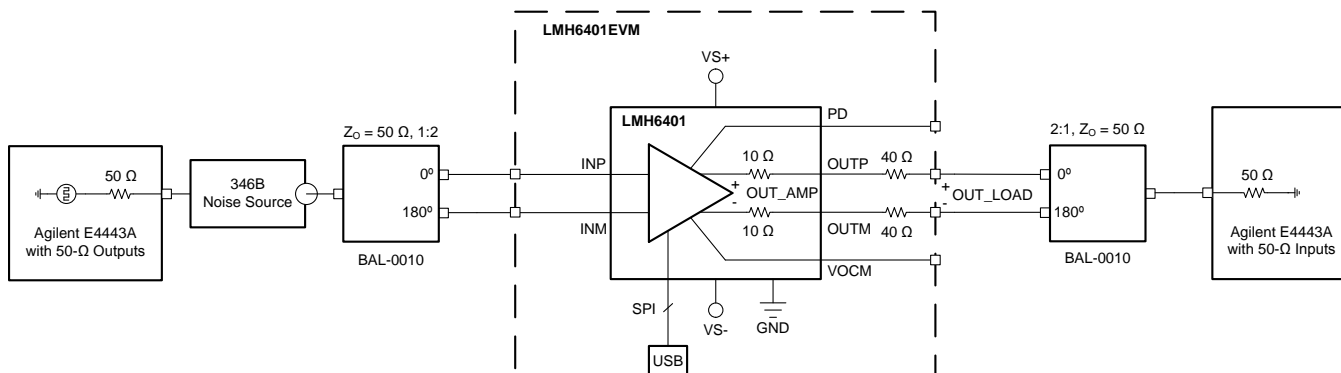

Figure 46. Noise Figure Test Setup

### 8.2 Output Measurement Reference Points

The LMH6401 has two on-chip, 10-Ω output resistors. When matching the output to a 100-Ω load, the evaluation module (EVM) uses an external 40-Ω resistor on each output leg to complete the output matching. Having on-chip output resistors creates two potential reference points for measuring the output voltage. The first reference point is at the internal amplifier output (OUT\_AMP), and the second reference point is at the externally-matched 100-Ω load (OUT\_LOAD). The measurements in the *Electrical Characteristics* table and in the *Typical Characteristics* section are referred to the (OUT\_AMP) reference point unless otherwise specified. The conversion between reference points is a straightforward correction of 3 dB for power and 6 dB for voltage, as shown in [Equation 1](#) and [Equation 2](#). The measurements are referenced to OUT\_AMP when not specified.

$$V_{OUT\_LOAD} = (V_{OUT\_AMP} - 6 \text{ dB}) \quad (1)$$

$$P_{OUT\_LOAD} = (P_{OUT\_AMP} - 3 \text{ dB}) \quad (2)$$

### 8.3 ATE Testing and DC Measurements

All production testing and dc parameters are measured on automated test equipment capable of dc measurements only. Some measurements (such as voltage gain) are referenced to the output of the internal amplifier and do not include losses attributed to the on-chip output resistors. The *Electrical Characteristics* values specify these conditions. When the measurement is referred to the amplifier output, the output resistors are not included in the measurement. If the measurement is referred to the device pins, then the output resistor loss is included in the measurement.

### 8.4 Frequency Response

This test is done by running an S-parameter sweep on a 4-port differential network analyzer using the standard EVM with no baluns; see [Figure 43](#). The inputs and outputs of the EVM are connected to the network analyzer using 50-Ω coaxial cables with all the ports set to a characteristic impedance ( $Z_0$ ) of 50 Ω.

The frequency response test with capacitive load is done by soldering the capacitor across the LMH6401 output pins. In this configuration, the on-chip, 10-Ω resistors on each output leg isolate the capacitive load from the amplifier output pins.

### 8.5 Distortion

The standard EVM is used for measuring both the single-tone harmonic distortion and two-tone intermodulation distortion; see [Figure 44](#) and [Figure 45](#), respectively. The distortion is measured with differential input signals to the LMH6401. In order to interface with single-ended test equipment, external baluns (1:2,  $Z_0 = 50 \Omega$ ) are required between the EVM output ports and the test equipment. The *Typical Characteristics* plots are created with Marki™ baluns, model number BAL-0010. These baluns are used to combine two single tones in the two-tone test plots as well as convert the single-ended input to differential output for harmonic distortion tests. The use of 6-dB attenuator pads on both the inputs and outputs is recommended to provide a balanced match between the external balun and the EVM.

## 8.6 Noise Figure

This test is done by matching the input of the LMH6401 to a 50- $\Omega$  noise source using a 1:2 balun (see [Figure 46](#)), with the noise figure being referred to the input impedance ( $R_S = 100 \Omega$ ). As noted in [Figure 46](#), an Agilent E4443A with NF features is used for the testing.

## 8.7 Pulse Response, Slew Rate, and Overdrive Recovery

For time-domain measurements, the standard EVM is driven through a balun again to convert a single-ended output from the test equipment to the differential inputs of the LMH6401. The differential outputs are directly connected to the oscilloscope inputs, with the differential signal response calculated using trace math from the two separate oscilloscope inputs.

## 8.8 Power Down

The standard EVM is used for this test by completely removing the shorting block on jumper JPD. A high-speed, 50- $\Omega$  pulse generator is used to drive the PD pin, which toggles the output signal on or off depending upon the PD pin voltage.

## 8.9 VOVM Frequency Response

The standard EVM is used for this test. A network analyzer is connected to the VOVM input of the EVM and the EVM outputs are connected to the network analyzer with 50- $\Omega$  coaxial cables. The network analyzer analysis mode is set to single-ended input and differential output, and the output common-mode response is measured with respect to the single-ended input (Scs21). The input signal frequency is swept with the signal level set for 100 mV (–16 dBm). Note that the common-mode control circuit gain is approximately one.

## 9 Detailed Description

### 9.1 Overview

The LMH6401 is a very high-performance, differential I/O, digitally-controlled variable gain amplifier (DVGA). The device is optimized for radio frequency (RF), intermediate frequency (IF), or high-speed time-domain applications with 3-dB bandwidths up to 4.5 GHz. The device is ideal for dc- or ac-coupled applications requiring a variable gain stage when driving an analog-to-digital converter (ADC).

The LMH6401 is best suited to optimize system linearity and noise performance over the entire gain range in the RF and IF bands. Operating on a nominal 5-V supply or  $\pm 2.5$ -V split supplies, the device consists of an attenuator stage followed by a fixed-gain amplifier to provide voltage gain control from  $-6$  dB to 26 dB in 1-dB steps (as shown in the *Functional Block Diagram* section) with an overall 32-dB gain range. The variable gain control for the device is offered through the digital serial peripheral interface (SPI) register. The device has a unique attenuator ladder architecture providing dynamic range improvements where the overall noise figure (NF) remains relatively constant for the first 5-dB attenuator steps, with NF degrading proportional to the attenuator steps on the sixth step. This behavior repeats over the entire gain range; see [Figure 26](#).

The device has a differential input impedance of  $100\text{-}\Omega$  and is intended to be driven differentially by a matched  $100\text{-}\Omega$  differential source impedance for the best linearity and noise performance. The LMH6401 has two on-chip,  $10\text{-}\Omega$  resistors, one on each output (as shown in the *Functional Block Diagram* section). For most load conditions, the  $10\text{-}\Omega$  resistors are only a partial termination. Consequently, external termination resistors are required in most applications. See [Table 11](#) for common load values and the matching resistors.

The LMH6401 supports a common-mode reference input (VOCM) pin to align the amplifier output common-mode with the subsequent stage (ADC) input requirements. The output common-mode of the LMH6401 is self-biased to mid-supply when the VOCM pin is not driven externally. The device can be operated on a power-supply voltage range of 4.0 V to 5.25 V and supports both single- and split-supply operation. For correct digital operation, the positive supply must not be below 2 V for ground reference logic. A power-down feature is also available through the SPI register and the external PD pin.

### 9.2 Functional Block Diagram

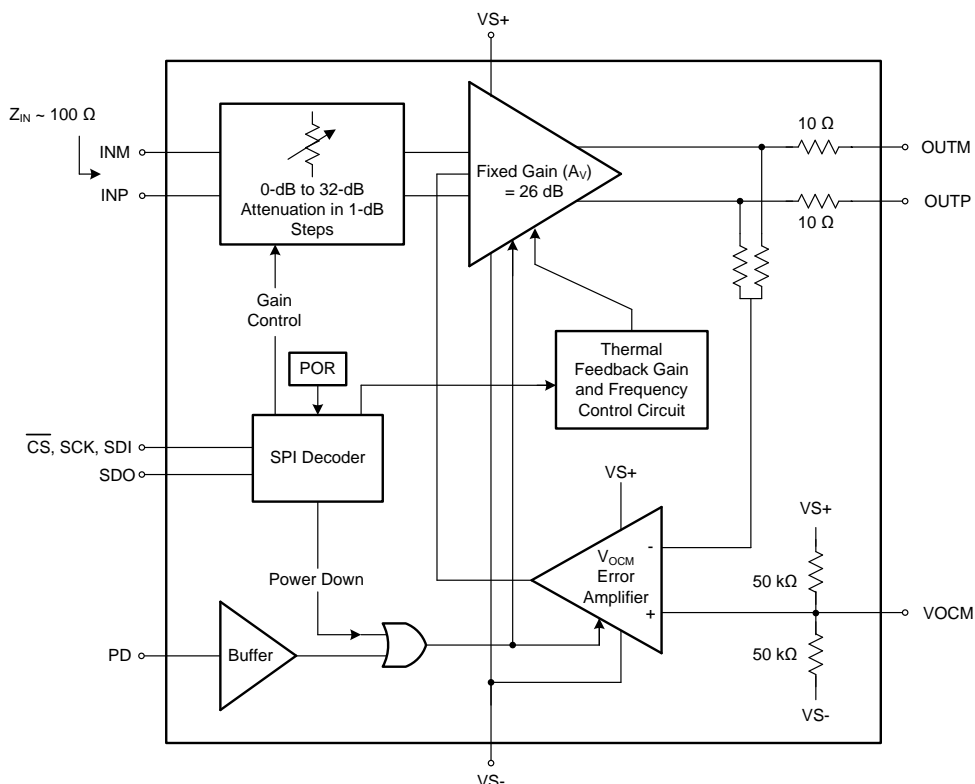

## 9.3 Feature Description

The LMH6401 includes the following features:

- Fully-differential amplifier
- Digitally-controlled variable gain: –6 dB to 26 dB in 1-dB steps
- Output common-mode control
- Single- or split-supply operation
- Large-signal bandwidth of 4.5 GHz
- Usable bandwidth up to 2 GHz
- Power-down control

## 9.4 Device Functional Modes

### 9.4.1 Power-On Reset (POR)

The LMH6401 has a built-in, power-on reset (POR) that sets the device registers to their default state (see [Table 3](#)) on power-up. Note that the LMH6401 register information is lost each time power is removed. When power is reapplied, the POR ensures the device enters a default state. Power glitches (of sufficient duration) can also initiate the POR and return the device to a default state.

### 9.4.2 Power-Down (PD)

The device supports power-down control using an external power-down (PD) pin or by writing a logic high to bit 6 of SPI register 2h (see the [Register Maps](#) section). The external PD is an active high pin. When left floating, the device defaults to an *on* condition when the PD pin defaults to logic low as a result of the internal pulldown resistor. The device PD thresholds are noted in the [Electrical Characteristics](#) table. The device consumes approximately 7 mA in power-down mode. Note that the SPI register contents are preserved in power-down mode.

### 9.4.3 Thermal Feedback Control

The LMH6401 has a thermal feedback gain and frequency control feature that allows for improved low-frequency settling performance. The [Thermal Feedback Gain Control](#) and [Thermal Feedback Frequency Control](#) registers set through the SPI control this feature. The default setting is described in [Table 3](#). Graphs are included in the [Application and Implementation](#) section that illustrate how the thermal feedback gain and frequency control allows for enhanced performance.

### 9.4.4 Gain Control

The LMH6401 gain can be controlled from 26-dB gain (0-dB attenuation) to –6-dB gain in 1-dB steps by digitally programming the SPI register 2h. See the [Register Maps](#) section for more details.

## 9.5 Programming

### 9.5.1 Details of the Serial Interface

The LMH6401 has a set of internal registers that can be accessed by the serial interface controlled by the  $\overline{CS}$  (chip select), SCLK (serial interface clock), SDI (serial interface input data), and SDO (serial interface readback data) pins. Serial input to the device is enabled when  $\overline{CS}$  is low. SDI serial data are latched at every SCLK rising edge when  $\overline{CS}$  is active (low). Serial data are loaded into the register at every 16th SCLK rising edge when  $\overline{CS}$  is low. When the word length exceeds a multiple of 16 bits, the excess bits are ignored. Data can be loaded in multiples of 16-bit words within a single active  $\overline{CS}$  pulse. The first eight bits form the register address and the remaining eight bits form the register data. The interface can function with SCLK frequencies from 50 MHz down to very low speeds (of a few Hertz) and also with a non-50% SCLK duty cycle. A summary of the LMH6401 SPI protocol follows:

- SPI-1.1 compliant interface
- SPI register contents protected in power-down
- SPI-controlled power-down
- Powered from the main VS+ power supply
- 1.8-V logic compliant

Programming (continued)

9.5.2 Timing Diagrams

Figure 47 and Figure 48 show timing diagrams for the SPI write and read bus cycles, respectively. Figure 49 and Figure 50 show timing diagrams for the write and read operations, respectively, of the LMH6401. Figure 51 and Figure 52 illustrate example SPI stream write and read timing diagrams, respectively. Refer to the *Electrical Characteristics* table for SPI timing requirements.

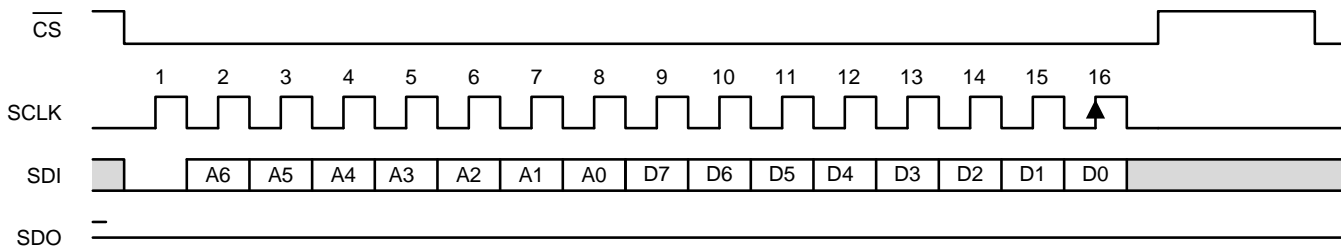

Figure 47. SPI Write Bus Cycle

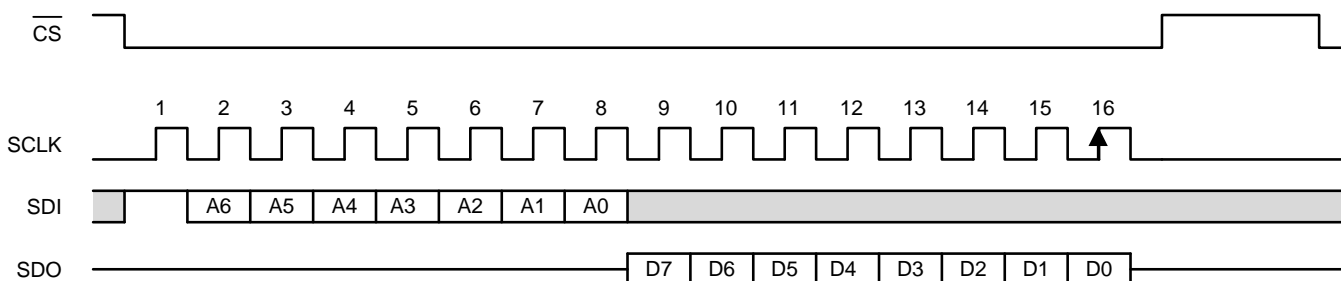

Figure 48. SPI Read Bus Cycle

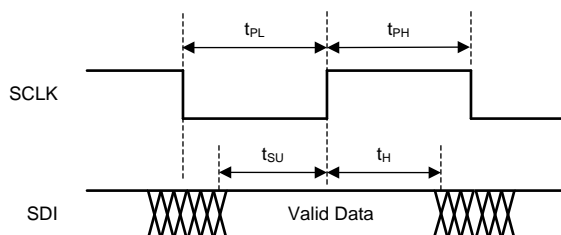

Figure 49. Write Operation Timing Diagram

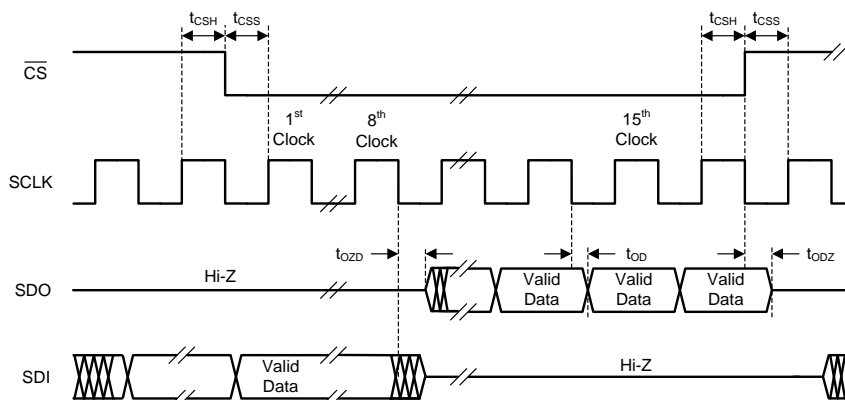
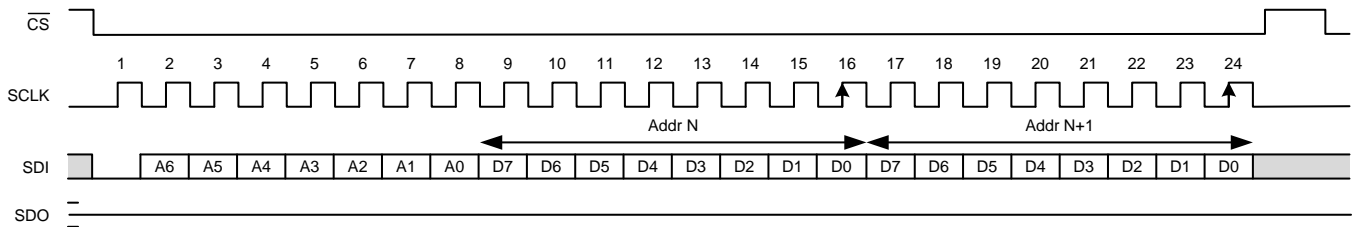
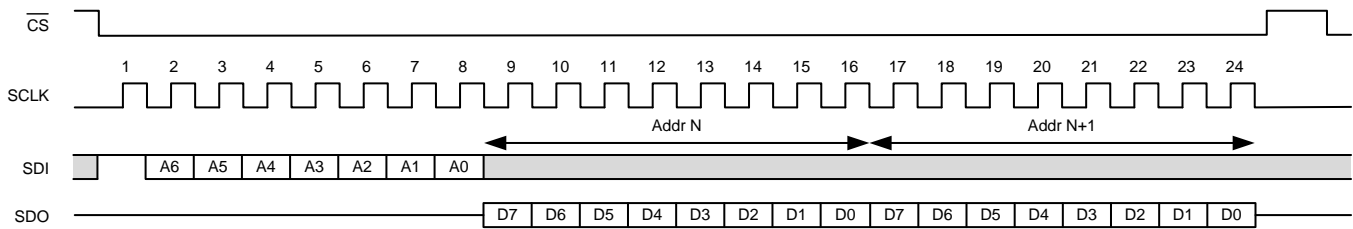

Figure 50. Read Operation Timing Diagram

**Programming (continued)**

**Figure 51. SPI Streaming Write Example**

**Figure 52. SPI Streaming Read Example**

## 9.6 Register Maps

Table 3 lists the SPI register map.

**Table 3. SPI Register Map**

ADDRESS (A[6:0])	R/W	REGISTER	DEFAULT (Hex)
0	R	Revision ID	03h
1	R	Product ID	00h
2	R/W	Gain Control	20h (minimum gain)
3	R/W	Reserved	8Ch
4	R/W	Thermal feedback gain control	27h
5	R/W	Thermal feedback frequency control	45h
6-127	R	Reserved	00h

### 9.6.1 Revision ID (address = 0h, Read-Only) [default = 03h]

**Figure 53. Revision ID**

7	6	5	4	3	2	1	0
Revision ID							
R-0b	R-0b	R-0b	R-0b	R-0b	R-0b	R-1b	R-1b

LEGEND: R = Read only; -n = value after reset

**Table 4. Revision ID Field Descriptions**

Bit	Field	Type	Default	Description
7-0	Revision ID	R	00000011	Revision identification bits.

### 9.6.2 Product ID (address = 1h, Read-Only) [default = 00h]

**Figure 54. Product ID**

7	6	5	4	3	2	1	0
Product ID							
R-0b	R-0b	R-0b	R-0b	R-0b	R-0b	R-0b	R-0b

LEGEND: R = Read only; -n = value after reset

**Table 5. Product ID Field Descriptions**

Bit	Field	Type	Default	Description
7-0	Product ID	R	00000000	Product identification bits.

**9.6.3 Gain Control (address = 2h) [default = 20h]**
**Figure 55. Gain Control**

7	6	5	4	3	2	1	0
Reserved	Power Down	Gain Control					
R/W-0b	R/W-0b	R/W-1b	R/W-0b	R/W-0b	R/W-0b	R/W-0b	R/W-0b

LEGEND: R/W = Read/Write; -n = value after reset

**Table 6. Gain Control Field Description**

Bit	Field	Type	Default	Description
7	Reserved	R/W	0	Reserved, always program to 0
6	Power Down	R/W	0	0 = Active 1 = Power down
5-0	Gain Control	R/W	100000	Gain control (see <a href="#">Table 10</a> for gain settings)

**9.6.4 Reserved (address = 3h) [default = 8Ch]**
**Figure 56. Reserved**

7	6	5	4	3	2	1	0
Reserved							
R/W-1b	R/W-0b	R/W-0b	R/W-0b	R/W-1b	R/W-1b	R/W-0b	R/W-0b

LEGEND: R/W = Read/Write; -n = value after reset

**Table 7. Reserved Field Descriptions**

Bit	Field	Type	Default	Description
7-0	Reserved	R/W	10001100	Reserved

**9.6.5 Thermal Feedback Gain Control (address = 4h) [default = 27h]**
**Figure 57. Thermal Feedback Gain Control**

7	6	5	4	3	2	1	0
Reserved	Reserved	Thermal SD	Thermal Feedback Gain Control				
R/W-0b	R/W-0b	R/W-1b	R/W-0b	R/W-0b	R/W-1b	R/W-1b	R/W-1b

LEGEND: R/W = Read/Write; -n = value after reset

**Table 8. Thermal Feedback Gain Control Field Descriptions**

Bit	Field	Type	Default	Description
7-6	Reserved	R/W	00	Reserved, always program to 00
5	Thermal SD	R/W	1	0 = Thermal feedback control enabled 1 = Thermal feedback control disabled
4-0	Thermal Feedback Gain Control	R/W	00111	00000 = Minimum thermal feedback gain (see <a href="#">Figure 61</a> ) 11111 = Maximum thermal feedback gain (see <a href="#">Figure 61</a> )

### 9.6.6 Thermal Feedback Frequency Control (address = 5h) [default = 45h]

**Figure 58. Thermal Feedback Frequency Control**

7	6	5	4	3	2	1	0
Reserved	Reserved	Reserved	Thermal Feedback Frequency Control				
R/W-0b	R/W-1b	R/W-0b	R/W-0b	R/W-0b	R/W-1b	R/W-0b	R/W-1b

LEGEND: R/W = Read/Write; -n = value after reset

**Table 9. Thermal Feedback Frequency Control Field Descriptions**

Bit	Field	Type	Default	Description
7-5	Reserved	R/W	010	Reserved, always program to 010
4-0	Thermal Feedback Frequency Control	R/W	00101	00000 = Minimum thermal feedback frequency (see <a href="#">Figure 62</a> ) 11111 = Maximum thermal feedback frequency (see <a href="#">Figure 62</a> )

**Table 10. Gain Control Register Controls**

ATTENUATION (dB)	GAIN (dB)	REGISTER SETTING (Address = 02h)
0	26	00h
1	25	01h
2	24	02h
3	23	03h
4	22	04h
5	21	05h
6	20	06h
7	19	07h
8	18	08h
9	17	09h
10	16	0Ah
11	15	0Bh
12	14	0Ch
13	13	0Dh
14	12	0Eh
15	11	0Fh
16	10	10h
17	9	11h
18	8	12h
19	7	13h
20	6	14h
21	5	15h
22	4	16h
23	3	17h
24	2	18h
25	1	19h
26	0	1Ah
27	-1	1Bh
28	-2	1Ch
29	-3	1Dh
30	-4	1Eh
31	-5	1Fh
32	-6	20h-3Fh

## 10 Application and Implementation

### NOTE

Information in the following applications sections is not part of the TI component specification, and TI does not warrant its accuracy or completeness. TI's customers are responsible for determining suitability of components for their purposes. Customers should validate and test their design implementation to confirm system functionality.

### 10.1 Application Information

#### 10.1.1 Analog Input Characteristics

The LMH6401 is a single-channel device with analog input signal pins (INP and INM) that denote the positive and negative input pins, respectively. The device inputs can be either ac- or dc-coupled. In order to dc-couple the inputs, care must be taken to ensure the common-mode voltage is set within the input common-mode range of the device, as described in the [Electrical Characteristics](#) table. For optimal linearity and noise performance, TI recommends setting the input common-mode voltage as close to mid-supply as possible. The LMH6401 device can be ac-coupled at the inputs using input capacitors that allow the inputs to self-bias close to mid-supply and isolates the common-mode voltage of the driving circuitry. The LMH6401 inputs must be driven differentially. For single-ended input source applications, care must be taken to select an appropriate balun or fully-differential amplifier (such as the [LMH3401](#) or [LMH5401](#)) that can convert single-ended signals into differential signals with minimal distortion.

At maximum gain, the digital attenuator is set to 0-dB attenuation, the input signal is much smaller than the output, and the maximum output voltage swing is limited by the output stage of the device. At minimum gain, however, the maximum output voltage swing is limited by the input stage because the output is 6 dB lower than the inputs. In the minimum gain configuration, the input signal begins to clip against the electrostatic discharge (ESD) protection diodes before the output reaches maximum swing limits. This clipping is a result of the input signal being unable to swing below the negative supply voltage and being unable to exceed the positive supply voltage because of the protection diodes. For linear operation, care must be taken to ensure that the input is kept within the maximum input voltage ratings, as described in the [Absolute Maximum Ratings](#) table. The supply voltage imposes the limit for the input voltage swing because the input stage self-biases to approximately mid-rail.

The device input impedance is set by the internal input termination resistors to a nominal value of 100  $\Omega$ . Process variations result in a range of values, as described in the [Electrical Characteristics](#) table. The input impedance is also affected by device parasitic reactance at higher frequencies, thus shifting the impedance away from a nominal 100  $\Omega$ . The LMH6401 exhibits a well-matched, 100- $\Omega$  differential input impedance in the usable bandwidth, achieving a  $-15$ -dB input return loss at 2 GHz across the gain settings; see [Figure 3](#). [Figure 59](#) illustrates a Smith chart plot of the LMH6401 differential input impedance referenced to a 100- $\Omega$  characteristic impedance.

Application Information (continued)

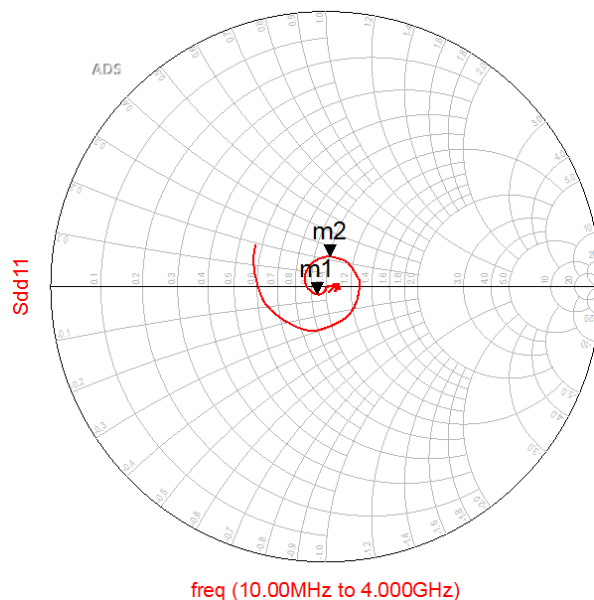

<p>m1 indep(m1)=5.000E8 plot_vs(Sdd11, freq)=0.042 / -138.511 impedance = Z0 * (0.938 - j0.052)</p>	<p>m2 indep(m2)=2.000E9 plot_vs(Sdd11, freq)=0.111 / 81.810 impedance = Z0 * (1.007 + j0.223)</p>
---	---

Figure 59. Smith Chart Showing Differential Input Impedance ( $z_0 = 100 \Omega$ )

10.1.2 Analog Output Characteristics

The LMH6401, as with most RF amplifiers, has two 10- $\Omega$ , on-chip resistors on each output leg to provide isolation from board parasitics at the output pins; see the *Functional Block Diagram* section. When designing a filter between the LMH6401 and the interfacing circuitry (ADC), the filter source impedance must be calculated by taking into account the two 10- $\Omega$ , on-chip resistors. Table 11 shows the calculated external source impedance values ( $R_{O+}$  and  $R_{O-}$ ) required for various matched filter loads ( $R_L$ ). An important note is that the filter design between the LMH6401 and the ADC is not limited to a matched filter, and source impedance values ( $R_{O+}$  and  $R_{O-}$ ) can be reduced to achieve higher swing at the filter outputs. Achieving lower loss in the filter source impedance resistors or higher swing at the filter outputs is often desirable because the amplifier must output reduced swing to maintain the same full-scale input at the ADC and, thus, better linearity performance. An example 370-MHz, un-matched, low-pass filter between the LMH6401 and ADS54J60 is illustrated in Figure 64, with ( $R_{O+}$  and  $R_{O-}$ ) set to 20  $\Omega$  and  $R_L$  set to 100  $\Omega$ .

Table 11. Load Component Values<sup>(1)</sup>

LOAD ( $R_L$ )	$R_{O+}$ AND $R_{O-}$ FOR A MATCHED TERMINATION	TOTAL LOAD RESISTANCE AT AMPLIFIER OUTPUT	TERMINATION LOSS
50 $\Omega$	15 $\Omega$	100 $\Omega$	6 dB
100 $\Omega$	40 $\Omega$	200 $\Omega$	6 dB
200 $\Omega$	90 $\Omega$	400 $\Omega$	6 dB
400 $\Omega$	190 $\Omega$	800 $\Omega$	6 dB
1 k $\Omega$	490 $\Omega$	2000 $\Omega$	6 dB

(1) The total load includes termination resistors.

The LMH6401 can be either dc- or ac-coupled at the outputs. For dc-coupled applications, the device provides an option to control the output common-mode voltage using the VO<sub>CM</sub> pin. Device performance is optimal when the output common-mode voltage is within  $\pm 0.5$  V of mid-supply (see [Figure 21](#)) and performance degrades outside the range when the output swing approaches clipping levels. The LMH6401 can achieve a maximum output swing of  $6 V_{PPD}$  with the output common-mode voltage centered at mid-supply.

Note that by default, the output common-mode voltage is set to mid-supply before the two 10- $\Omega$ , on-chip resistors; see the [Functional Block Diagram](#) section. On a single-supply operation when dc-coupling the device outputs to an ADC using common-mode, level-shifting resistors, the output common-mode voltage and resistor values being calculated must include the two internal 10- $\Omega$  resistors in the equation. When operating the LMH6401 on split supplies and dc-coupling the outputs, TI recommends matching the output common-mode voltage of the LMH6401 with the input common-mode voltage of the ADC. A simple design procedure is to select the supply voltages (V<sub>S+</sub> and V<sub>S-</sub>) such that the default output common-mode voltage being set is equal to the input common-mode voltage of the ADC. As illustrated in [Figure 66](#), the supplies of the LMH6401 are selected such that the default output common-mode voltage is set to mid-supply or 1.23 V, which is within the input common-mode voltage range of the ADC (1.185 V to 1.265 V).

### 10.1.2.1 Driving Capacitive Loads

With high-speed signal paths, capacitive loading at the output is highly detrimental to the signal path, as shown in [Figure 60](#). The device on-chip resistors are included in order to isolate the parasitic capacitance associated with the package and the printed circuit board (PCB) pads that the device is soldered to. However, designers must make every effort to reduce parasitic loading on the amplifier output pins. The LMH6401 is stable with most capacitive loads up to 10 pF; however, bandwidth suffers with capacitive loading on the output.

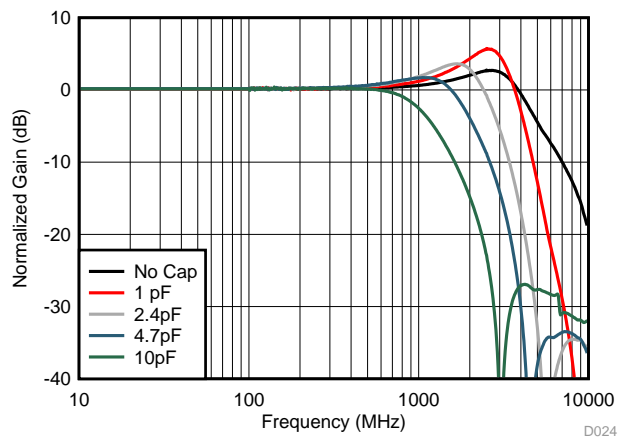

**Figure 60. Frequency Response vs Capacitive Load**

### 10.1.3 Thermal Feedback Control

The LMH6401 can be used to optimize long-term settling responses using thermal feedback gain and frequency control registers. These registers are disabled on power-up and can be enabled by clearing the thermal SD bit; see the [Thermal Feedback Gain Control](#) register. The thermal feedback gain control bits increase the low-frequency gain and the thermal feedback frequency control bits shift the boost frequency. The thermal feedback gain and frequency registers both have a range of 32 steps. When the function is enabled, there is a small initial gain offset to optimize the control range. The thermal feedback off condition is illustrated in the gain control plot ([Figure 61](#)), along with a sweep of gain settings of 0, 4, 8...28, and 31 with a 0 register value representing the minimum gain setting. The frequency control is illustrated in [Figure 62](#) with the optimal gain setting from the gain sweep over the values of 0, 4, 8...28, and 31 with a 0 register value representing the minimum frequency boost setting.

### 10.1.3.1 Step Response Optimization using Thermal Feedback Control

The LMH6401 has an adjustable frequency compensation scheme that is designed to dramatically improve the step response for long-term settling. The structure of the LMH6401 gives the best distortion performance for signals ranging from dc to 2 GHz over a wide range of gain settings. Thermal heating causes a small change in gain at low frequencies close to 500 kHz. This change in gain is shown in [Figure 61](#) in the ac response for the trace labeled *Thermal Feedback OFF*. The amount of gain change is approximately 0.18 dB at maximum gain. This gain change resulting from thermal heating leads to approximately 1.7% overshoot that settles over a relatively long time period. A patent pending technique is added that allows for the reduction of this overshoot to approximately 0.35%, thus eliminating the long-term settling and still retaining the wide dynamic performance range. The circuit also corrects for small systematic changes that occur at different gain settings and tracks temperature changes as well. This low-frequency gain correction is accomplished by the addition of a circuit that alters the gain at low frequencies to nearly eliminate the variation from low to high frequencies.

The step response optimization circuit is disabled on power-up and can be enabled by clearing bit 5 in the [Thermal Feedback Gain Control](#) register (register 4h). The power-on default setting for thermal gain and frequency are adjusted for the evaluation board for typical silicon performance. These registers are made available for customization in the final system because board layout characteristics or other components in the system can change the required correction needed.

[Figure 63](#) demonstrates the initial step response and the corrected response that corresponds to the default register values for a typical device on the evaluation board displaying long-term settling correction.

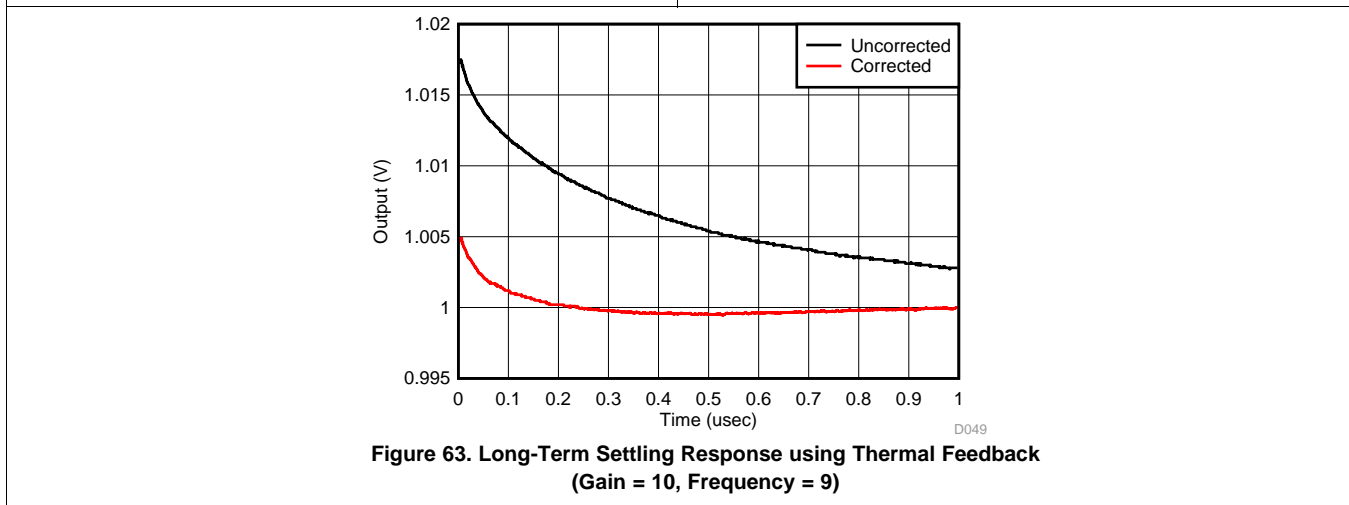
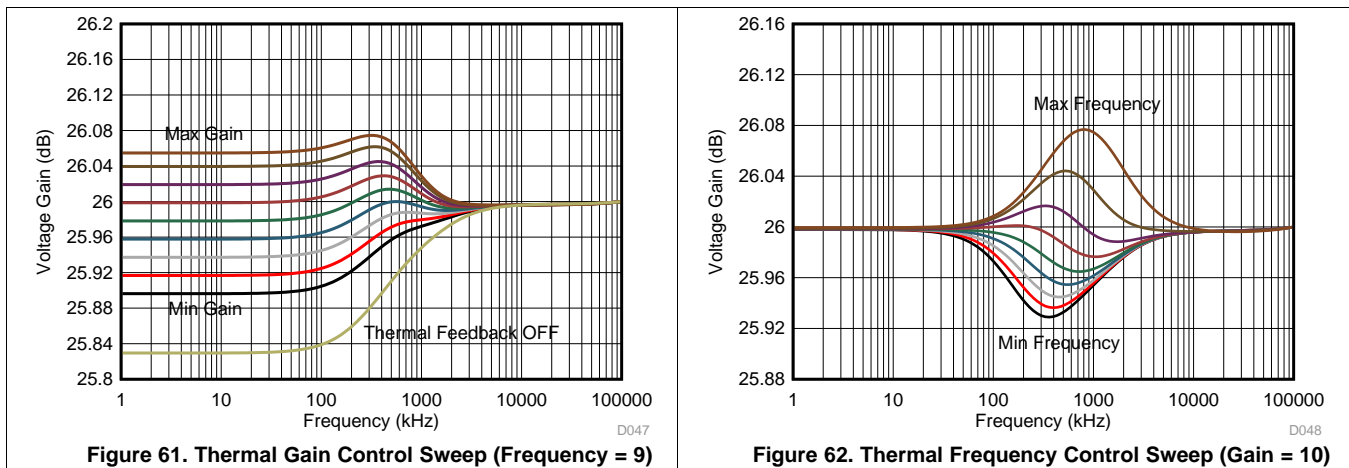

**10.1.4 Thermal Considerations**

The LMH6401 is packaged in a space-saving UQFN package that has a thermal coefficient ( $R_{\theta JA}$ ) of 78°C/W. Limit the total power dissipation in order to keep the device junction temperature below 150°C for instantaneous power and below 125°C for continuous power.

**10.2 Typical Application**

The LMH6401 is designed and optimized for the highest performance when driving differential input ADCs. Figure 64 shows a block diagram of the LMH6401 driving an ADC with a fourth-order, low-pass filter. The primary interface circuit between the amplifier and the ADC is usually an antialiasing filter to suppress high-frequency harmonics aliasing into the ADC FFT spectrum. The interface circuit also provides a means to bias the signal to the input common-mode voltage required by the ADC. Filters range from single-order real RC poles to higher-order RLC filters, depending on the application requirements. Output resistors ( $R_O$ ) in series with the amplifier outputs isolate the amplifier from any capacitive load presented by the filter.

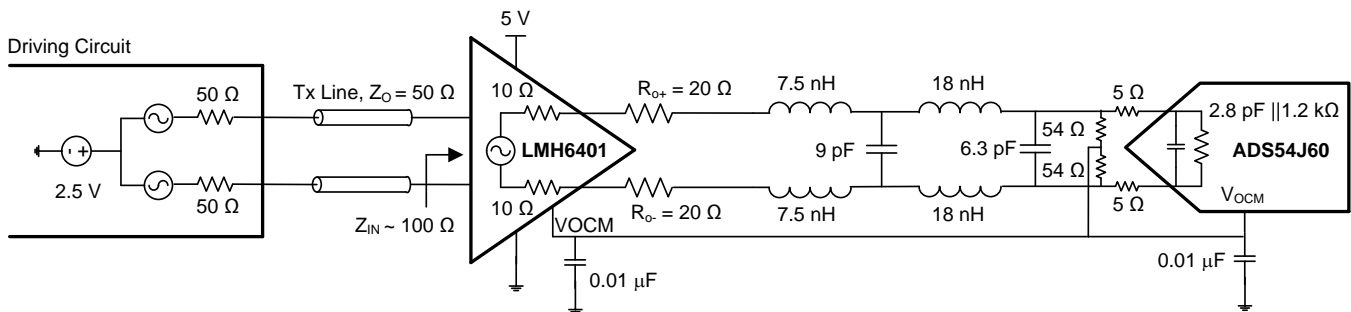

**Figure 64. The LMH6401 Driving an ADS54J60 with a 370 MHz Fourth-Order Chebyshev Low-Pass Filter**

Low distortion and low noise figure, along-with low power dissipation make the LMH6401 an ideal device for use in front-end radio applications. Figure 65 shows a block diagram of a one-transmit and one-receive (1T/1R) radio architecture with a digital pre-distortion path, where the LMH6401 can be used as a variable-gain IF amplifier on both the transmit and receive signal chain.

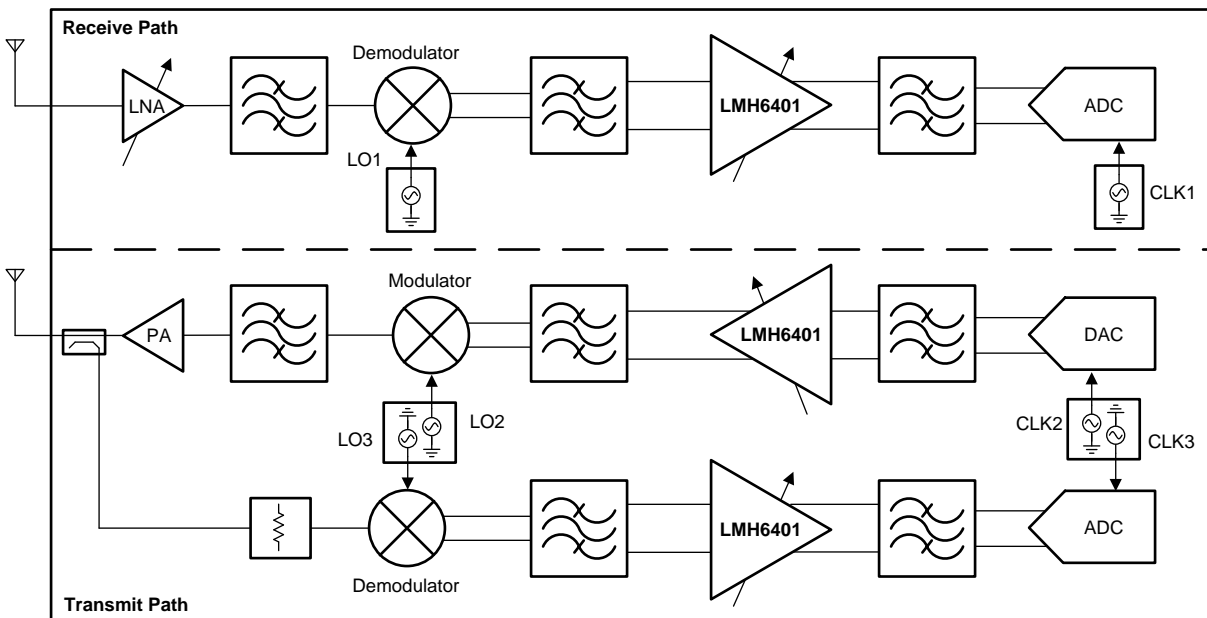

**Figure 65. 1T/1R with Digital Pre-Distortion Front-End Radio Application**

## Typical Application (continued)

### 10.2.1 Design Requirements

Table 12 shows example design requirements for an amplifier in an oscilloscope front-end application; the LMH6401 meets these requirements.

**Table 12. Example Design Requirements for an Oscilloscope Front-End application**

SPECIFICATION	DESIGN REQUIREMENTS
Supply voltage and current	4.0 V to 5.25 V with typically less than a 100-mA current and split-supply operation supported
Usable input frequency range	DC to 2 GHz
Voltage gain and gain range	26-dB to 10-dB voltage gain with x2 attenuation supported (ideal 32-dB gain range)
OIP3 ( $P_{O} = -2$ dBm per tone, $R_L = 200 \Omega$ ) and noise figure ( $R_S = 100 \Omega$ ) at 1 GHz	> 30 dBm and less than 10 dB, respectively.
Rise and fall time ( $V_O = 2$ -V step) from 10% to 90%	Less than 100 ps
Settling time to 1% of $V_O = 2$ -V step	Less than 1 ns with long-term settling correction required

### 10.2.2 Detailed Design Procedure

#### 10.2.2.1 Driving ADCs

When the amplifier is driving an ADC, the key points to consider for implementation are the signal-to-noise ratio (SNR), spurious-free dynamic range (SFDR), and ADC input considerations, as described in this section.

A typical application of the LMH6401 involves driving an ultra-wideband, 12-bit ADC (such as the ADC12J4000), as shown in Figure 66. The LMH6401 can drive the full Nyquist bandwidth of ADCs with sampling rates up to 4 GSPS. If the front-end bandwidth of the ADC is more than 2 GHz, use a simple noise filter to improve SNR. Otherwise, the ADC can be connected directly to the amplifier output pins with appropriate matching resistors to limit the full-scale input of the ADC. Note that the LMH6401 inputs must be driven differentially using a balun or fully-differential amplifiers (FDAs). For dc-coupled applications, an FDA (such as the LMH3401 or LMH5401) that can convert a single-ended input to a differential output with low distortion is preferred.

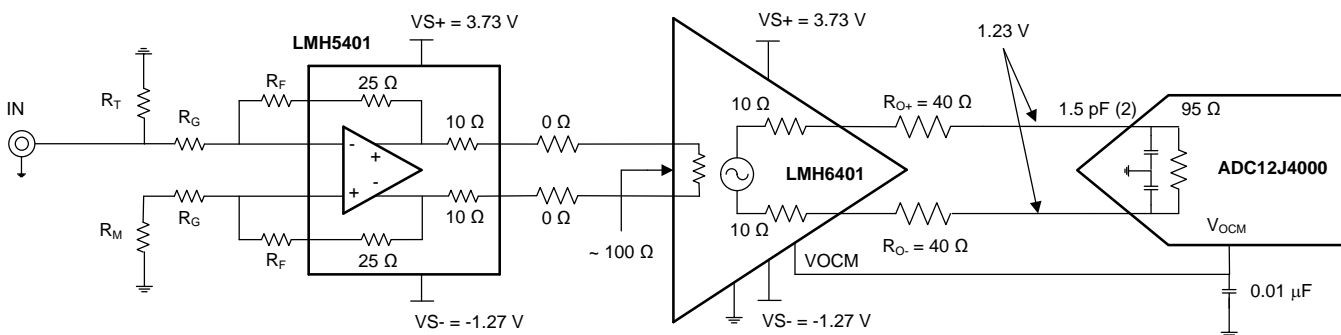

**Figure 66. DC-Coupled Oscilloscope Front-End Application**

### 10.2.2.1.1 SNR Considerations

The signal-to-noise ratio (SNR) of the amplifier and filter can be calculated from the amplitude of the signal and the bandwidth of the filter. The noise from the amplifier is band-limited by the filter with the equivalent brick-wall filter bandwidth. The amplifier and filter noise can be calculated using [Equation 3](#):

$$\text{SNR}_{\text{AMP+FILTER}} = 10 \cdot \log \left[ \frac{V_O^2}{e_{\text{FILTEROUT}}^2} \right] = 20 \cdot \log \left[ \frac{V_O}{e_{\text{FILTEROUT}}} \right]$$

where:

- $e_{\text{FILTEROUT}} = e_{\text{NAMPOUT}} \cdot \sqrt{\text{ENB}}$ ,
- $e_{\text{NAMPOUT}}$  = the output noise density of the LMH6401 (30.4 nV/√Hz) at  $A_V = 26$  dB,
- ENB = the brick-wall equivalent noise bandwidth of the filter, and
- $V_O$  = the amplifier output signal. (3)

For example, with a first-order ( $N = 1$ ) band-pass or low-pass filter with a 1000-MHz cutoff, ENB is  $1.57 \cdot f_{-3\text{dB}} = 1.57 \cdot 1000 \text{ MHz} = 1570 \text{ MHz}$ . For second-order ( $N = 2$ ) filters, ENB is  $1.22 \cdot f_{-3\text{dB}}$ . When the filter order increases, ENB approaches  $f_{-3\text{dB}}$  ( $N = 3 \rightarrow \text{ENB} = 1.15 \cdot f_{-3\text{dB}}$ ;  $N = 4 \rightarrow \text{ENB} = 1.13 \cdot f_{-3\text{dB}}$ ). Both  $V_O$  and  $e_{\text{FILTEROUT}}$  are in RMS voltages. For example, with a  $2\text{-}V_{\text{PP}}$  ( $0.707 V_{\text{RMS}}$ ) output signal and a 1000-MHz first-order, low-pass filter, the SNR of the amplifier and filter is 55.4 dB with  $e_{\text{FILTEROUT}} = 30.4 \text{ nV}/\sqrt{\text{Hz}} \cdot \sqrt{1570 \text{ MHz}} = 1204.5 \mu\text{V}_{\text{RMS}}$ .

The SNR of the amplifier, filter, and ADC sum in RMS fashion, as shown in [Equation 4](#) (SNR values in dB):

$$\text{SNR}_{\text{SYSTEM}} = -20 \cdot \log \left[ \sqrt{10^{\frac{-\text{SNR}_{\text{AMP+FILTER}}}{10}} + 10^{\frac{-\text{SNR}_{\text{ADC}}}{10}}} \right] \quad (4)$$

This formula shows that if the SNR of the amplifier and filter equals the SNR of the ADC, the combined SNR is 3 dB lower (worse). Thus, for minimal degradation ( $< 1$  dB) on the ADC SNR, the SNR of the amplifier and filter must be  $\geq 10$  dB greater than the ADC SNR. The combined SNR calculated in this manner is usually accurate to within  $\pm 1$  dB of the actual implementation.

### 10.2.2.1.2 SFDR Considerations

The SFDR of the amplifier is usually set by the second- or third-harmonic distortion for single-tone inputs, and by the second-order or third-order intermodulation distortion for two-tone inputs. Harmonics and second-order intermodulation distortion can be filtered to some degree, but third-order intermodulation spurs cannot be filtered. The ADC generates the same distortion products as the amplifier, but also generates additional spurs (not harmonically related to the input signal) as a result of sampling and clock feed through.

When the spurs from the amplifier and filter are known, each individual spur can be directly added to the same spur from the ADC, as shown in [Equation 5](#), to estimate the combined spur (spur amplitudes in dBc):

$$\text{HDX}_{\text{SYSTEM}} = -20 \cdot \log \left[ 10^{\frac{-\text{HDX}_{\text{AMP+FILTER}}}{20}} + 10^{\frac{-\text{HDX}_{\text{ADC}}}{20}} \right] \quad (5)$$

This calculation assumes the spurs are in phase, but usually provides a good estimate of the final combined distortion.

For example, if the spur of the amplifier and filter equals the spur of the ADC, then the combined spur is 6 dB higher. To minimize the amplifier contribution ( $< 1$  dB) to the overall system distortion, the spur from the amplifier and filter must be approximately 15 dB lower in amplitude than that of the converter. The combined spur calculated in this manner is usually accurate to within  $\pm 6$  dB of the actual implementation; however, higher variations can be detected as a result of phase shift in the filter, especially in second-order harmonic performance.

This worst-case spur calculation assumes that the amplifier and filter spur of interest is in phase with the corresponding spur in the ADC, such that the two spur amplitudes can be added linearly. There are two phase-shift mechanisms that cause the measured distortion performance of the amplifier-ADC chain to deviate from the expected performance calculated using [Equation 5](#); one is the common-mode phase shift and other is the differential phase shift.

*Common-mode phase shift* is the phase shift detected equally in both branches of the differential signal path including the filter. Common-mode phase shift nullifies the basic assumption that the amplifier, filter, and ADC spur sources are in phase. This phase shift can lead to better performance than predicted when the spurs become phase shifted, and there is the potential for cancellation when the phase shift reaches 180°. However, there is a significant challenge in designing an amplifier-ADC interface circuit to take advantage of a common-mode phase shift for cancellation: the phase characteristics of the ADC spur sources are unknown, thus the necessary phase shift in the filter and signal path for cancellation is also unknown.

*Differential phase shift* is the difference in the phase response between the two branches of the differential filter signal path. Differential phase shift in the filter is a result of mismatched components caused by nominal tolerances and can severely degrade the even harmonic distortion of the amplifier-ADC chain. This effect has the same result as mismatched path lengths for the two differential traces, and causes more phase shift in one path than the other. Ideally, the phase responses over frequency through the two sides of a differential signal path are identical, such that even harmonics remain optimally out of phase and cancel when the signal is taken differentially. However, if one side has more phase shift than the other, then the even harmonic cancellation is not as effective.

Single-order RC filters cause very little differential phase shift with nominal tolerances of 5% or less, but higher-order LC filters are very sensitive to component mismatch. For instance, a third-order Butterworth band-pass filter with a 100-MHz center frequency and a 20-MHz bandwidth shows as much as 20° of differential phase imbalance in a SPICE Monte Carlo analysis with 2% component tolerances. Therefore, although a prototype may work, production variance is unacceptable. For ac-coupled or dc-coupled applications where a transformer or balun cannot be used, using first- or second-order filters is recommended to minimize the effect of differential phase shift.

#### 10.2.2.1.3 ADC Input Common-Mode Voltage Considerations—AC-Coupled Input

When interfacing to an ADC, the input common-mode voltage range of the ADC must be taken into account for proper operation. In an ac-coupled application between the amplifier and the ADC, the input common-mode voltage bias of the ADC can be accomplished in different ways. Some ADCs use internal bias networks such that the analog inputs are automatically biased to the required input common-mode voltage if the inputs are ac-coupled with capacitors (or if the filter between the amplifier and ADC is a band-pass filter). Other ADCs supply their required input common-mode voltage from a reference voltage output pin (often termed CM or  $V_{CM}$ ). With these ADCs, the ac-coupled input signal can be re-biased to the input common-mode voltage by connecting resistors from each input to the CM output of the ADC, as shown in Figure 67. AC coupling provides dc common-mode isolation between the amplifier and the ADC; thus, the output common-mode voltage of the amplifier is a *don't care* for the ADC.

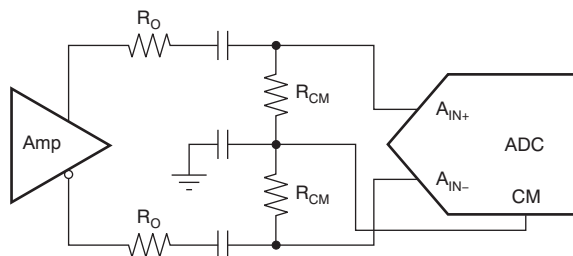
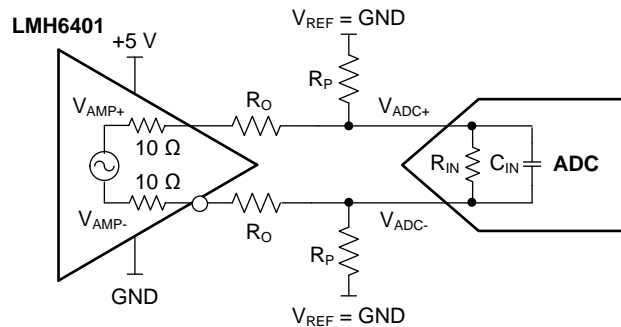

Figure 67. Biasing AC-Coupled ADC Inputs Using the ADC CM Output

#### 10.2.2.1.4 ADC Input Common-Mode Voltage Considerations—DC-Coupled Input

DC-coupled applications vary in complexity and requirements, depending on the ADC (a split supply for the CMV is applicable). One typical requirement is resolving the mismatch between the common-mode voltage of the driving amplifier and the ADC. Devices such as the ADC12J4000 require a nominal 1.23-V input common-mode, whereas other devices such as the ADS54J60 require a nominal 2.1-V input common-mode. The simplest approach when dc-coupling the LMH6401 with the input common-mode voltage of the ADC is to select the supply voltages ( $V_{S+}$ ) and ( $V_{S-}$ ) such that the default output common-mode voltage being set is equal to the input common-mode voltage of the ADC; see Figure 66. The default common-mode voltage being set can be controlled externally using the VO<sub>CM</sub> pin. The device performance is optimal when the output common-mode voltage is within ±0.5 V of mid-supply and degrades outside the range when the output swing approaches clipping levels.

A second approach is shown in [Figure 68](#) when dc-coupling on a single supply, where a resistor network can be used to perform the common-mode level shift. This resistor network consists of the amplifier series output resistors and pullup or pulldown resistors to a reference voltage. This resistor network introduces signal attenuation that may prevent the use of the full-scale input range of the ADC. ADCs with an input common-mode closer to the typical 2.5-V output common-mode of the LMH6401 are easier to dc-couple, and require little or no level shifting.



**Figure 68. Resistor Network to DC Level-Shift Common-Mode Voltage using  $V_{REF}$  as GND**

For common-mode analysis of the circuit in [Figure 68](#), assume that  $V_{AMP\pm} = V_{CM}$  and  $V_{ADC\pm} = V_{CM}$  (the specification for the ADC input common-mode voltage). Note that the  $V_{AMP\pm}$  common-mode voltage is set before the two internal 10- $\Omega$  resistors, making these resistors necessary to include in the common-mode level-shift resistor calculation.  $V_{REF}$  is chosen to be a voltage within the system higher than  $V_{CM}$  (such as the ADC or amplifier analog supply) or ground, depending on whether the voltage must be pulled up or down, respectively;  $R_O$  is chosen to be a reasonable value, such as 24.9  $\Omega$ . With these known values,  $R_P$  can be found by using [Equation 6](#):

$$R_P = (10 + R_O) \times (V_{ADC} - V_{REF}) / (V_{AMP} - V_{ADC}) \quad (6)$$

Shifting the common-mode voltage with the resistor network comes at the expense of signal attenuation. Modeling the ADC input as the parallel combination of a resistance ( $R_{IN}$ ) and capacitance ( $C_{IN}$ ) using values taken from the ADC data sheet, the approximate differential input impedance ( $Z_{IN}$ ) for the ADC can be calculated at the signal frequency. The effect of  $C_{IN}$  on the overall calculation of gain is typically minimal and can be ignored for simplicity (that is,  $Z_{IN} = R_{IN}$ ). The ADC input impedance creates a divider with the resistor network; the gain (attenuation) for this divider can be calculated by [Equation 7](#):

$$\text{Gain} = (2R_P \parallel Z_{IN}) / (20 + 2R_O + 2R_P \parallel Z_{IN}) \quad (7)$$

With ADCs that have internal resistors that bias the ADC input to the ADC input common-mode voltage, the effective  $R_{IN}$  is equal to twice the value of the bias resistor. For example, the ADS54J60 has a 0.6-k $\Omega$  resistor tying each input to the ADC  $V_{CM}$ ; therefore, the effective differential  $R_{IN}$  is 1.2 k $\Omega$ .

The introduction of the  $R_P$  resistors also modifies the effective load that must be driven by the amplifier. [Equation 8](#) shows the effective load created when using the  $R_P$  resistors.

$$R_L = 20 + 2R_O + 2R_P \parallel Z_{IN} \quad (8)$$

The  $R_P$  resistors function in parallel to the ADC input such that the effective load (output current) at the amplifier output is increased. Higher current loads limit the LMH6401 differential output swing.

Using the gain and knowing the full-scale input of the ADC ( $V_{ADC FS}$ ), the required amplitude to drive the ADC with the network can be calculated using [Equation 9](#):

$$V_{AMP PP} = \frac{V_{ADC FS}}{\text{GAIN}} \quad (9)$$

As with any design, testing is recommended to validate whether the specific design goals are met.

### 10.2.3 Application Curves

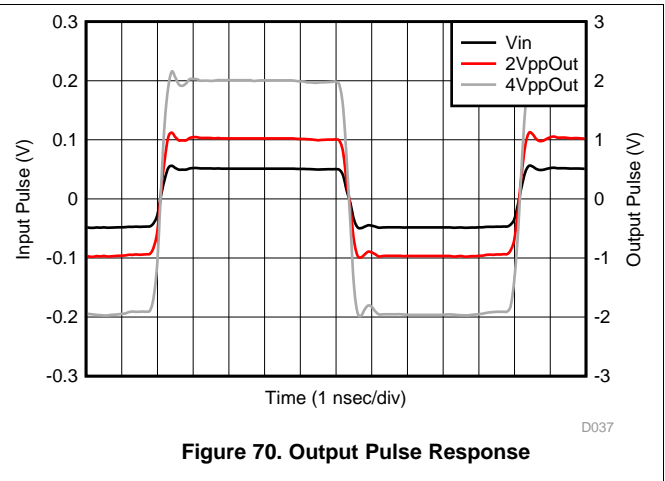
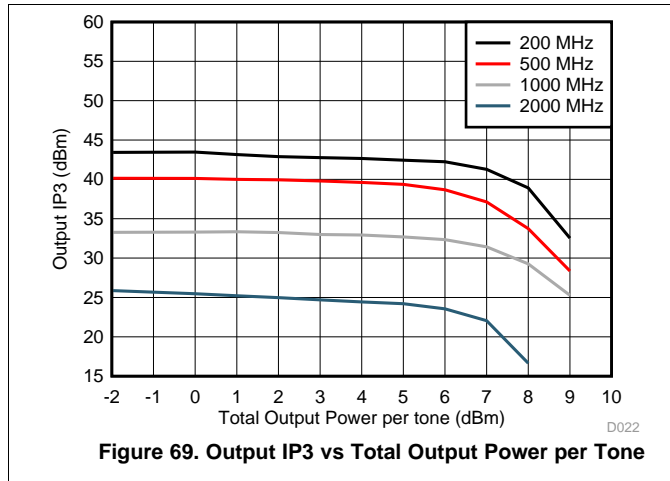

## 10.3 Do's and Don'ts

### 10.3.1 Do:

- Include a thermal analysis at the beginning of the project.
- Use well-terminated transmission lines for all signals.
- Maintain symmetrical input and output trace layouts
- Use solid metal layers for the power supplies.
- Keep signal lines as straight as possible.
- Use split supplies where required.

### 10.3.2 Don't:

- Use a lower supply voltage than necessary.
- Use thin metal traces to supply power.
- Forget about the common-mode response of filters and transmission lines.
- Rout digital line traces close to the analog signals and supply line traces

## 11 Power-Supply Recommendations

The LMH6401 supports both single- or split-supply operation with a total recommended supply operating range  $[(V_{S+}) - (V_{S-})]$  from 4.0 V to 5.25 V. Note that supply voltages do not need to be symmetrical when using split supplies, provided the total supply voltage is within the recommended operating range. Any combination of positive ( $V_{S+}$ ) and negative ( $V_{S-}$ ) supply voltages is acceptable, as long as the minimum positive ( $V_{S+}$ ) supply voltage to ground is 2 V, or greater.

Using a single 5-V power supply gives the best balance of performance and power dissipation. If power dissipation is a critical design parameter, a power supply as low as 4.0 V ( $\pm 2.0$  V) can be used. The input common-mode and output swing limitations of the device scale with supply voltage. TI recommends studying the common-mode voltage and output swing limitations (see the [Electrical Characteristics](#) table) before deciding to use a lower supply voltage.

### 11.1 Single-Supply Operation

The device supports single-ended supply voltages with  $V_{S+}$  connected to a positive voltage from 4.0 V to 5.25 V and  $V_{S-}$  connected to ground reference. When using a single supply, check to make sure the input and output common-mode voltages are within the operating range of the device. Best performance is achieved when the input and output common-mode voltages are centered close to mid-supply.

### 11.2 Split-Supply Operation

Using split supplies provides the most flexibility in system design. To operate on split supplies, apply the positive supply voltage to  $V_{S+}$ , the negative supply voltage to  $V_{S-}$ , and the ground reference to GND. Note that supply voltages do not need to be symmetrical, as long as the minimum positive ( $V_{S+}$ ) supply voltage to ground is 2 V, or greater. The split-supply operation is often beneficial when the output common-mode of the device must be set to a particular voltage. For best performance (see [Figure 21](#) and [Figure 22](#)), TI recommends that the power-supply voltages be symmetrical around the desired output common-mode voltage. The input common-mode voltage range is much more flexible than the output. For example, if the LMH6401 is used to drive an ADC with a 1.0-V input common mode, then the ideal supply voltages are 3.5 V and  $-1.5$  V with the output common-mode voltage of the LMH6401 centered at 1.0 V for best linearity and noise performance. The GND pin can then be connected to the system ground and the PD pin and SPI pins are ground referenced.

TI recommends powering up the device with low-noise, LDO-type regulators. If a switching-type regulator is used to improve system power efficiency, following the switching-type regulator with a low-noise LDO is recommended to provide the best possible filtering of the switching noise. An example low-noise switcher and LDO for generating negative supply voltages are the [LMR70503](#) and [TPS72301](#), respectively. In a system with multiple devices being powered on from the same voltage regulator, a high possibility of noise being coupled between the multiple devices exists. Additionally, when operated on a board with high-speed digital signals, isolation must be provided between the digital signal noise and the LMH6401 supply pins. Therefore, adding additional series ferrite beads or isolation devices and decoupling capacitors is recommended to filter out any power-supply noise and improve isolation.

Power-supply decoupling is critical to filter out high-frequency switching noise coupling into the supply pins. Decoupling the supply pins with low ESL, 0306-size ceramic capacitors of X7R-type 0.01- $\mu$ F and 2200-pF values are recommended. In addition to the decoupling capacitors, the supply bypassing can be provided by the PCB, as illustrated in [Layout Guidelines](#) section.

## 12 Layout

### 12.1 Layout Guidelines

When dealing with a device with relatively high gain and bandwidth in excess of 1 GHz, certain board layout precautions must be taken to ensure stability and optimum performance. TI recommends that the LMH6401 board be multi-layered to improve thermal performance, grounding, and power-supply decoupling. The differential input and output traces must be symmetrical in order to achieve the best linearity performance.

By sandwiching the power-supply layer between ground layers on either side (with thin dielectric thicknesses), parasitic capacitance between power and ground functions as a distributed, high-resonance frequency capacitor to help with power-supply decoupling. The LMH6401 evaluation board includes a total of six layers and the positive (VS+) and negative (VS-) power planes are sandwiched in the middle with a board stack-up (dielectric thickness), as shown in Figure 71, to help with supply decoupling. Both VS+ and VS- must be connected to the internal power planes through multiple vias in the immediate vicinity of the supply pins. In addition, low ESL, ceramic, 0.01- $\mu$ F decoupling capacitors to the supplies are placed on the same layer as the device to provide supply decoupling.

Routing high-frequency signal traces on a PCB requires careful attention to maintain signal integrity. A board layout software package can simplify the trace thickness design to maintain impedances for controlled impedance signals. In order to isolate the affect of board parasitic on frequency response, TI recommends placing the external output matching resistors close to the amplifier output pins. A 0.01- $\mu$ F bypass capacitor is also recommended close to the VO<sub>CM</sub> pins to suppress high-frequency common-mode noise. Refer to the user guide [LMH6401EVM Evaluation Module \(SLOU406\)](#) for more details on board layout and design.

In order to improve board mechanical reliability, the LMH6401 has square anchor pins on four corners of the package that must be soldered to the board for mechanical strength.

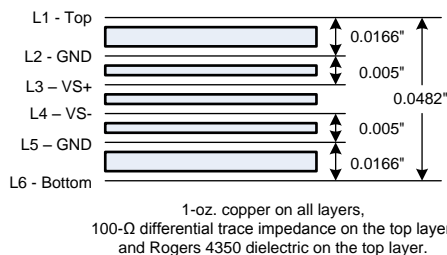

**Figure 71. Recommended PCB Layer Stack-Up for a Six-Layer Board**

## 12.2 Layout Examples

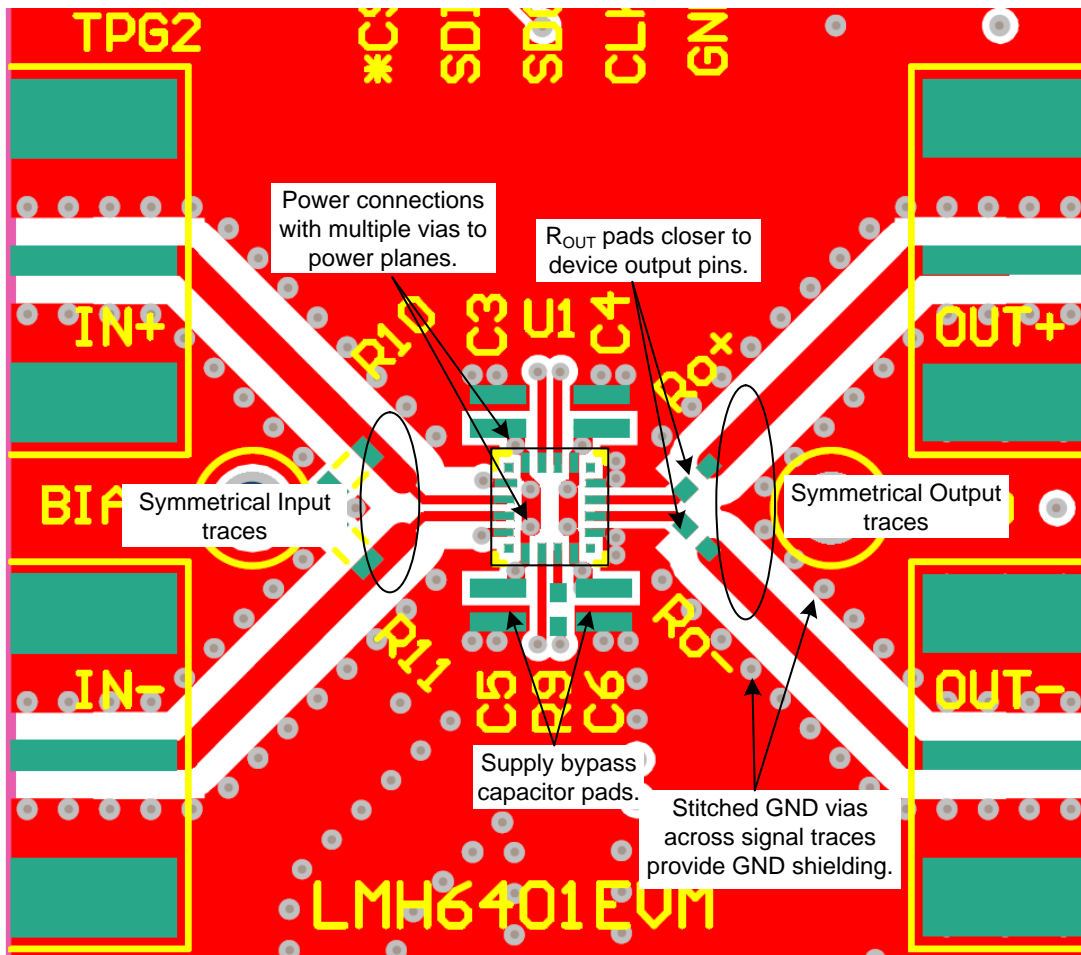

Figure 72. EVM Top Layer



Figure 73. EVM Second Layer Showing a Solid GND Plane

## 13 Device and Documentation Support

### 13.1 Documentation Support

#### 13.1.1 Related Documentation

For related documentation see the following:

- ADS12D1800RF Data Sheet, [SNAS518](#)
- ADC12J1600, ADC12J2700 Data Sheet, [SLAS969](#)
- ADC12J4000 Data Sheet, [SLAS989](#)
- ADS54J40 Data Sheet, [SBAS714](#)
- ADS54J60 Data Sheet, [SBAS706](#)
- LMH3401 Data Sheet, [SBOS695](#)
- LMH5401 Data Sheet, [SBOS710](#)
- LMH6517 Data Sheet, [SNOSB19](#)
- LMH6521 Data Sheet, [SNOSB47](#)
- LMH6554 Data Sheet, [SNOSB30](#)
- LMH6881 Data Sheet, [SNOSC72](#)
- LMR70503 Data Sheet, [SNVS850](#)
- TPS72301 Data Sheet, [SLVS346](#)
- *AN-2188 Between the Amplifier and the ADC: Managing Filter Loss in Communications Systems*, [SNOA567](#)
- *AN-2235 Circuit Board Design for LMH6517/21/22 and Other High-Speed IF/RF Feedback Amplifiers*, [SNOA869](#)
- *LMH6401EVM Evaluation Module*, [SLOU406](#)

### 13.2 Community Resources

The following links connect to TI community resources. Linked contents are provided "AS IS" by the respective contributors. They do not constitute TI specifications and do not necessarily reflect TI's views; see TI's [Terms of Use](#).

**TI E2E™ Online Community** *TI's Engineer-to-Engineer (E2E) Community*. Created to foster collaboration among engineers. At [e2e.ti.com](http://e2e.ti.com), you can ask questions, share knowledge, explore ideas and help solve problems with fellow engineers.

**Design Support** *TI's Design Support* Quickly find helpful E2E forums along with design support tools and contact information for technical support.

### 13.3 Trademarks

E2E is a trademark of Texas Instruments.

Marki is a trademark of Marki Microwave, Inc.

SPI is a trademark of Motorola Mobility LLC.

All other trademarks are the property of their respective owners.

### 13.4 Electrostatic Discharge Caution



This integrated circuit can be damaged by ESD. Texas Instruments recommends that all integrated circuits be handled with appropriate precautions. Failure to observe proper handling and installation procedures can cause damage.

ESD damage can range from subtle performance degradation to complete device failure. Precision integrated circuits may be more susceptible to damage because very small parametric changes could cause the device not to meet its published specifications.

### 13.5 Glossary

[SLYZ022](#) — *TI Glossary*.

This glossary lists and explains terms, acronyms, and definitions.

## 14 Mechanical, Packaging, and Orderable Information

The following pages include mechanical, packaging, and orderable information. This information is the most current data available for the designated devices. This data is subject to change without notice and revision of this document. For browser-based versions of this data sheet, refer to the left-hand navigation.

**PACKAGING INFORMATION**

Orderable Device	Status (1)	Package Type	Package Drawing	Pins	Package Qty	Eco Plan (2)	Lead/Ball Finish (6)	MSL Peak Temp (3)	Op Temp (°C)	Device Marking (4/5)	Samples
LMH6401IRMZR	ACTIVE	UQFN-HR	RMZ	16	3000	Green (RoHS & no Sb/Br)	CU SN	Level-2-260C-1 YEAR	-40 to 85	MH6401	<a href="#">Samples</a>
LMH6401IRMZT	ACTIVE	UQFN-HR	RMZ	16	250	Green (RoHS & no Sb/Br)	CU SN	Level-2-260C-1 YEAR	-40 to 85	MH6401	<a href="#">Samples</a>

(1) The marketing status values are defined as follows:

**ACTIVE:** Product device recommended for new designs.

**LIFEBUY:** TI has announced that the device will be discontinued, and a lifetime-buy period is in effect.

**NRND:** Not recommended for new designs. Device is in production to support existing customers, but TI does not recommend using this part in a new design.

**PREVIEW:** Device has been announced but is not in production. Samples may or may not be available.

**OBSELETE:** TI has discontinued the production of the device.

(2) Eco Plan - The planned eco-friendly classification: Pb-Free (RoHS), Pb-Free (RoHS Exempt), or Green (RoHS & no Sb/Br) - please check <http://www.ti.com/productcontent> for the latest availability information and additional product content details.

**TBD:** The Pb-Free/Green conversion plan has not been defined.

**Pb-Free (RoHS):** TI's terms "Lead-Free" or "Pb-Free" mean semiconductor products that are compatible with the current RoHS requirements for all 6 substances, including the requirement that lead not exceed 0.1% by weight in homogeneous materials. Where designed to be soldered at high temperatures, TI Pb-Free products are suitable for use in specified lead-free processes.

**Pb-Free (RoHS Exempt):** This component has a RoHS exemption for either 1) lead-based flip-chip solder bumps used between the die and package, or 2) lead-based die adhesive used between the die and leadframe. The component is otherwise considered Pb-Free (RoHS compatible) as defined above.

**Green (RoHS & no Sb/Br):** TI defines "Green" to mean Pb-Free (RoHS compatible), and free of Bromine (Br) and Antimony (Sb) based flame retardants (Br or Sb do not exceed 0.1% by weight in homogeneous material)

(3) MSL, Peak Temp. - The Moisture Sensitivity Level rating according to the JEDEC industry standard classifications, and peak solder temperature.

(4) There may be additional marking, which relates to the logo, the lot trace code information, or the environmental category on the device.

(5) Multiple Device Markings will be inside parentheses. Only one Device Marking contained in parentheses and separated by a "~" will appear on a device. If a line is indented then it is a continuation of the previous line and the two combined represent the entire Device Marking for that device.

(6) Lead/Ball Finish - Orderable Devices may have multiple material finish options. Finish options are separated by a vertical ruled line. Lead/Ball Finish values may wrap to two lines if the finish value exceeds the maximum column width.

**Important Information and Disclaimer:**The information provided on this page represents TI's knowledge and belief as of the date that it is provided. TI bases its knowledge and belief on information provided by third parties, and makes no representation or warranty as to the accuracy of such information. Efforts are underway to better integrate information from third parties. TI has taken and continues to take reasonable steps to provide representative and accurate information but may not have conducted destructive testing or chemical analysis on incoming materials and chemicals. TI and TI suppliers consider certain information to be proprietary, and thus CAS numbers and other limited information may not be available for release.

In no event shall TI's liability arising out of such information exceed the total purchase price of the TI part(s) at issue in this document sold by TI to Customer on an annual basis.

**TAPE AND REEL INFORMATION**

**QUADRANT ASSIGNMENTS FOR PIN 1 ORIENTATION IN TAPE**

\*All dimensions are nominal

Device	Package Type	Package Drawing	Pins	SPQ	Reel Diameter (mm)	Reel Width W1 (mm)	A0 (mm)	B0 (mm)	K0 (mm)	P1 (mm)	W (mm)	Pin1 Quadrant
LMH6401IRMZR	UQFN-HR	RMZ	16	3000	180.0	16.5	3.3	3.3	0.75	8.0	12.0	Q2
LMH6401IRMZT	UQFN-HR	RMZ	16	250	180.0	16.5	3.3	3.3	0.75	8.0	12.0	Q2

**TAPE AND REEL BOX DIMENSIONS**

\*All dimensions are nominal

Device	Package Type	Package Drawing	Pins	SPQ	Length (mm)	Width (mm)	Height (mm)
LMH6401IRMZR	UQFN-HR	RMZ	16	3000	205.0	200.0	30.0
LMH6401IRMZT	UQFN-HR	RMZ	16	250	205.0	200.0	30.0

# RMZ0016A

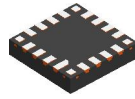

# PACKAGE OUTLINE

## UQFN - 0.65 mm max height

PLASTIC QUAD FLATPACK - NO LEAD

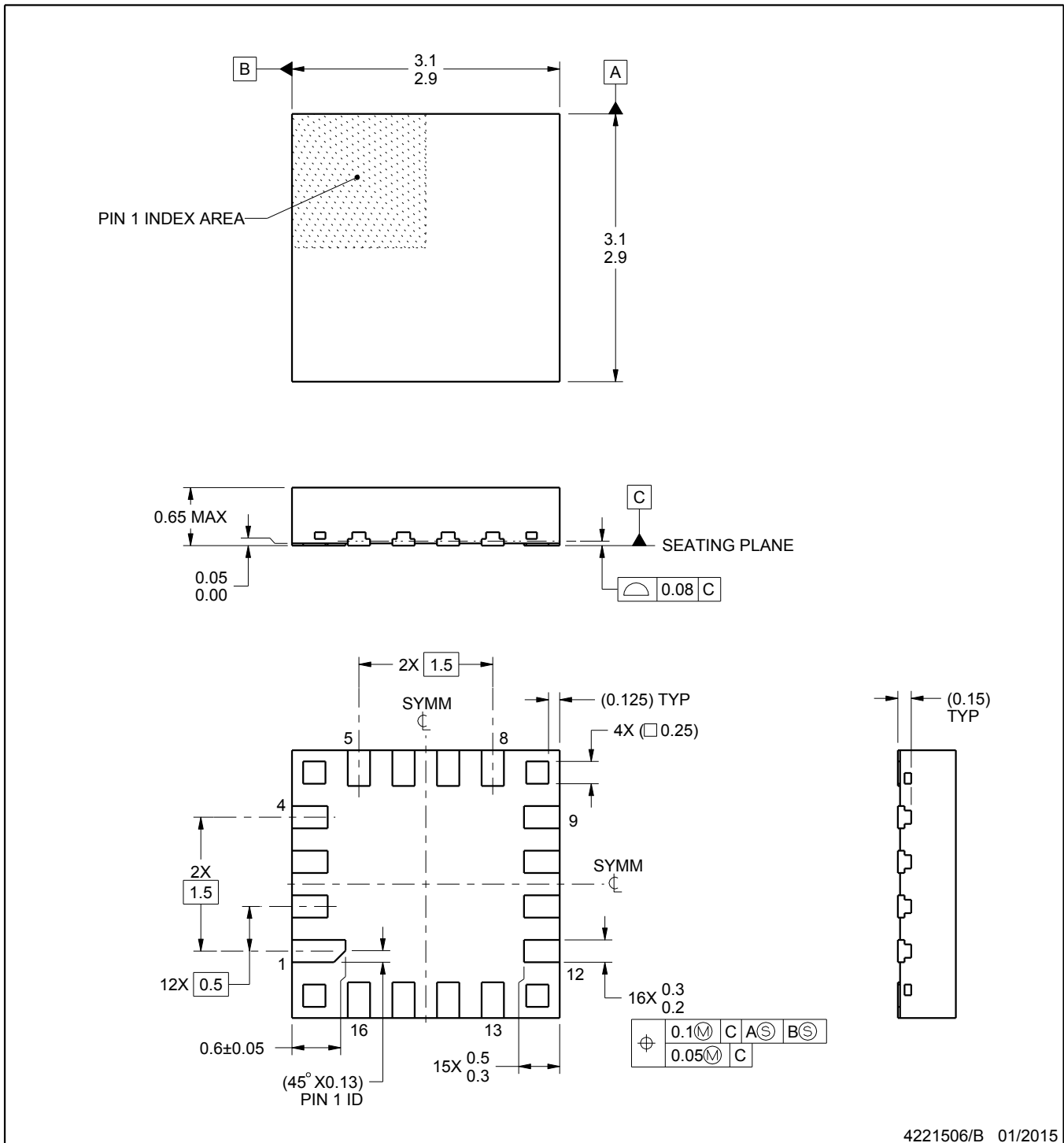

### NOTES:

1. All linear dimensions are in millimeters. Any dimensions in parenthesis are for reference only. Dimensioning and tolerancing per ASME Y14.5M.
2. This drawing is subject to change without notice.

# EXAMPLE BOARD LAYOUT

RMZ0016A

UQFN - 0.65 mm max height

PLASTIC QUAD FLATPACK - NO LEAD

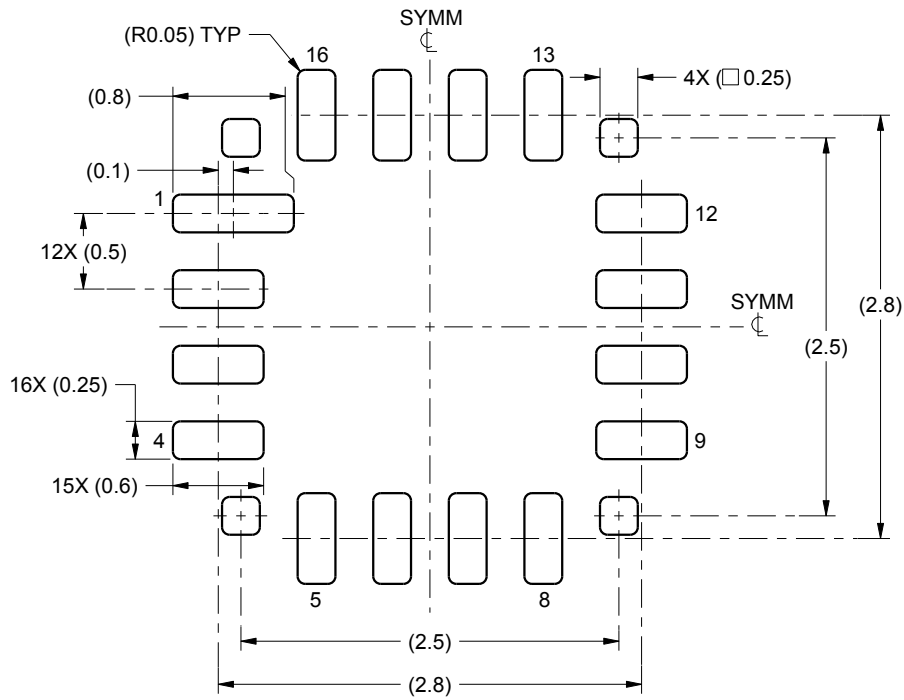

LAND PATTERN EXAMPLE  
SCALE:20X

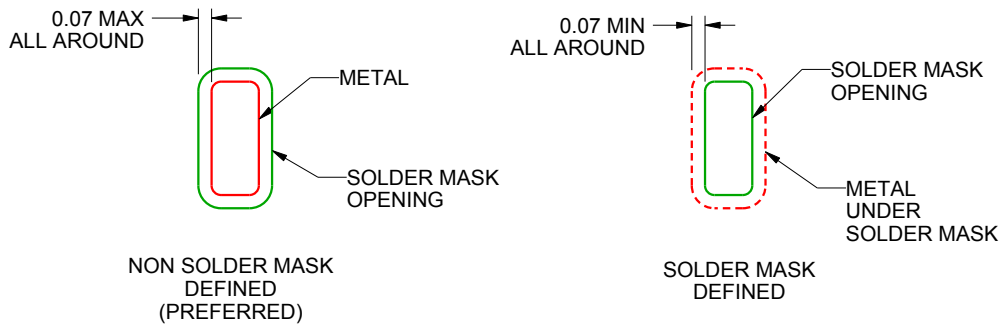

SOLDER MASK DETAILS  
NOT TO SCALE

4221506/B 01/2015

NOTES: (continued)

3. For more information, see Texas Instruments literature number SLUA271 ([www.ti.com/lit/slua271](http://www.ti.com/lit/slua271)).

# EXAMPLE STENCIL DESIGN

RMZ0016A

UQFN - 0.65 mm max height

PLASTIC QUAD FLATPACK - NO LEAD

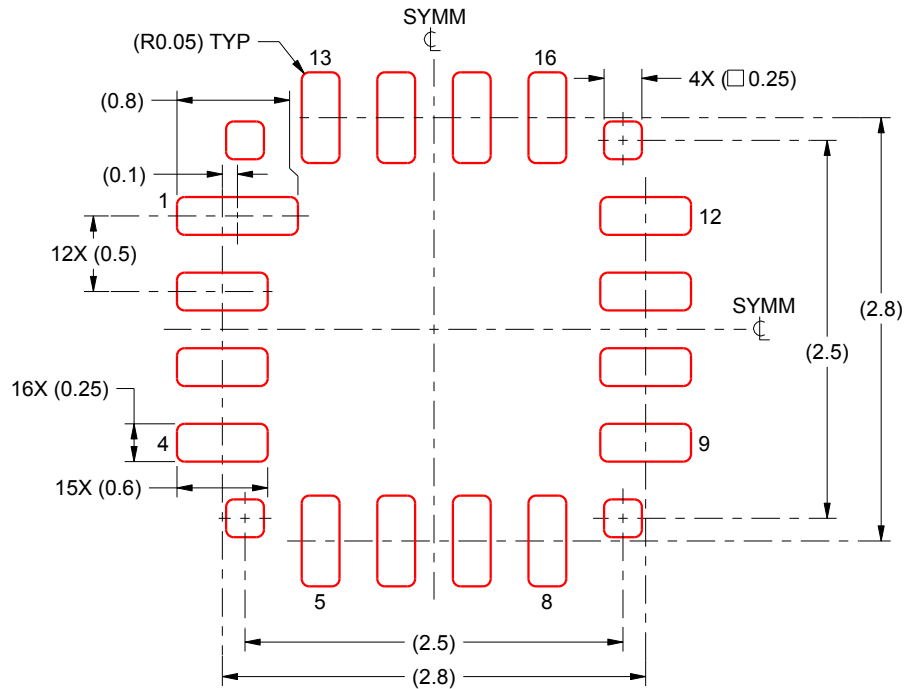

SOLDER PASTE EXAMPLE  
BASED ON 0.125 mm THICKNESS  
SCALE:20X

4221506/B 01/2015

NOTES: (continued)

4. Laser cutting apertures with trapezoidal walls and rounded corners may offer better paste release. IPC-7525 may have alternate design recommendations.

## IMPORTANT NOTICE

Texas Instruments Incorporated and its subsidiaries (TI) reserve the right to make corrections, enhancements, improvements and other changes to its semiconductor products and services per JESD46, latest issue, and to discontinue any product or service per JESD48, latest issue. Buyers should obtain the latest relevant information before placing orders and should verify that such information is current and complete. All semiconductor products (also referred to herein as "components") are sold subject to TI's terms and conditions of sale supplied at the time of order acknowledgment.

TI warrants performance of its components to the specifications applicable at the time of sale, in accordance with the warranty in TI's terms and conditions of sale of semiconductor products. Testing and other quality control techniques are used to the extent TI deems necessary to support this warranty. Except where mandated by applicable law, testing of all parameters of each component is not necessarily performed.

TI assumes no liability for applications assistance or the design of Buyers' products. Buyers are responsible for their products and applications using TI components. To minimize the risks associated with Buyers' products and applications, Buyers should provide adequate design and operating safeguards.

TI does not warrant or represent that any license, either express or implied, is granted under any patent right, copyright, mask work right, or other intellectual property right relating to any combination, machine, or process in which TI components or services are used. Information published by TI regarding third-party products or services does not constitute a license to use such products or services or a warranty or endorsement thereof. Use of such information may require a license from a third party under the patents or other intellectual property of the third party, or a license from TI under the patents or other intellectual property of TI.

Reproduction of significant portions of TI information in TI data books or data sheets is permissible only if reproduction is without alteration and is accompanied by all associated warranties, conditions, limitations, and notices. TI is not responsible or liable for such altered documentation. Information of third parties may be subject to additional restrictions.

Resale of TI components or services with statements different from or beyond the parameters stated by TI for that component or service voids all express and any implied warranties for the associated TI component or service and is an unfair and deceptive business practice. TI is not responsible or liable for any such statements.

Buyer acknowledges and agrees that it is solely responsible for compliance with all legal, regulatory and safety-related requirements concerning its products, and any use of TI components in its applications, notwithstanding any applications-related information or support that may be provided by TI. Buyer represents and agrees that it has all the necessary expertise to create and implement safeguards which anticipate dangerous consequences of failures, monitor failures and their consequences, lessen the likelihood of failures that might cause harm and take appropriate remedial actions. Buyer will fully indemnify TI and its representatives against any damages arising out of the use of any TI components in safety-critical applications.

In some cases, TI components may be promoted specifically to facilitate safety-related applications. With such components, TI's goal is to help enable customers to design and create their own end-product solutions that meet applicable functional safety standards and requirements. Nonetheless, such components are subject to these terms.

No TI components are authorized for use in FDA Class III (or similar life-critical medical equipment) unless authorized officers of the parties have executed a special agreement specifically governing such use.

Only those TI components which TI has specifically designated as military grade or "enhanced plastic" are designed and intended for use in military/aerospace applications or environments. Buyer acknowledges and agrees that any military or aerospace use of TI components which have **not** been so designated is solely at the Buyer's risk, and that Buyer is solely responsible for compliance with all legal and regulatory requirements in connection with such use.

TI has specifically designated certain components as meeting ISO/TS16949 requirements, mainly for automotive use. In any case of use of non-designated products, TI will not be responsible for any failure to meet ISO/TS16949.

### Products

Audio	<a href="http://www.ti.com/audio">www.ti.com/audio</a>
Amplifiers	<a href="http://amplifier.ti.com">amplifier.ti.com</a>
Data Converters	<a href="http://dataconverter.ti.com">dataconverter.ti.com</a>
DLP® Products	<a href="http://www.dlp.com">www.dlp.com</a>
DSP	<a href="http://dsp.ti.com">dsp.ti.com</a>
Clocks and Timers	<a href="http://www.ti.com/clocks">www.ti.com/clocks</a>
Interface	<a href="http://interface.ti.com">interface.ti.com</a>
Logic	<a href="http://logic.ti.com">logic.ti.com</a>
Power Mgmt	<a href="http://power.ti.com">power.ti.com</a>
Microcontrollers	<a href="http://microcontroller.ti.com">microcontroller.ti.com</a>
RFID	<a href="http://www.ti-rfid.com">www.ti-rfid.com</a>
OMAP Applications Processors	<a href="http://www.ti.com/omap">www.ti.com/omap</a>
Wireless Connectivity	<a href="http://www.ti.com/wirelessconnectivity">www.ti.com/wirelessconnectivity</a>

### Applications

Automotive and Transportation	<a href="http://www.ti.com/automotive">www.ti.com/automotive</a>
Communications and Telecom	<a href="http://www.ti.com/communications">www.ti.com/communications</a>
Computers and Peripherals	<a href="http://www.ti.com/computers">www.ti.com/computers</a>
Consumer Electronics	<a href="http://www.ti.com/consumer-apps">www.ti.com/consumer-apps</a>
Energy and Lighting	<a href="http://www.ti.com/energy">www.ti.com/energy</a>
Industrial	<a href="http://www.ti.com/industrial">www.ti.com/industrial</a>
Medical	<a href="http://www.ti.com/medical">www.ti.com/medical</a>
Security	<a href="http://www.ti.com/security">www.ti.com/security</a>
Space, Avionics and Defense	<a href="http://www.ti.com/space-avionics-defense">www.ti.com/space-avionics-defense</a>
Video and Imaging	<a href="http://www.ti.com/video">www.ti.com/video</a>

### TI E2E Community

[e2e.ti.com](http://e2e.ti.com)

## Looking for pricing, stock, or lifecycle information?

Click below to explore more details on WIN SOURCE:

 [View LMH6401IRMZT on WIN SOURCE](#)

 [Texas Instruments](#) Information

## Optimize Your Supply Chain with WIN SOURCE Solutions

-  Global Sourcing Solution
-  Obsolete Management
-  Cost Control Management
-  Shortage Management
-  Alternative Solution
-  Excess Inventory Management