



**THE DATASHEET OF  
DS2770BE+**



### FEATURES

- Integrated charge controller supporting both rechargeable lithium and NiMH battery technologies
- Available in two configurations:
  - Internal 25mΩ current-sense resistor
  - External user-selectable sense resistor
- Current measurement:
  - 15-bit bidirectional measurement
  - Internal sense resistor configuration: 62.5μA LSB and ±2A dynamic range
  - External sense resistor configuration: 1.56μV LSB and ±51.2mV dynamic range
- Current accumulation
  - Internal sense resistor: 0.25mAh LSB
  - External sense resistor: 6.25μVh LSB
- Voltage measurement with 4.88mV resolution
- Temperature measurement using integrated sensor with 0.125°C resolution
- 40 bytes of lockable EEPROM
- 16 bytes of general-purpose SRAM
- 42-day timer
- Dallas 1-Wire<sup>®</sup> interface with 64-bit ID
- 1.8V logic levels
- Low power consumption:
  - Active current: 80μA typical
  - Sleep current: 0.5μA typical

### PIN ASSIGNMENT

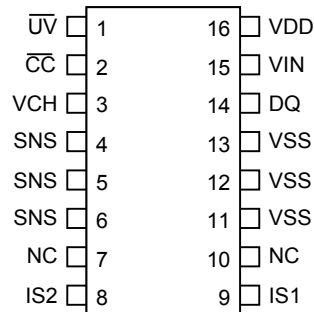

DS2770  
16-Pin TSSOP

### PIN DESCRIPTION

- UV – Battery-Undervoltage Detect Output
- CC – Charge-Control Output
- VCH – Charge-Supply Input
- SNS – Sense Resistor Connection
- IS2 – Current-Sense Input
- IS1 – Current-Sense Input
- VSS – Device Ground
- DQ – Data Input/Output
- VIN – Voltage-Sense Input
- VDD – Power Supply Input
- NC – No Connect

### DESCRIPTION

The DS2770 battery monitor and charge controller performs several functions needed for thorough battery maintenance. When used in conjunction with the host system's processor, a battery-pack resident DS2770 may be utilized for applications that include charging, remaining capacity estimation, safety monitoring, and nonvolatile (NV) parametric storage. *Description continued on page 2.*

**ORDERING INFORMATION**

| ORDERING NUMBER  | MARKING | DESCRIPTION  |
|------------------|---------|--|
| DS2770AE+        | D2770EA | TSSOP, Ext. Sense Res., 4.1V Charge Voltage, Lead-Free |
| DS2770BE+        | D2770EB | TSSOP, Ext. Sense Res., 4.2V Charge Voltage, Lead-Free |
| DS2770AE+T&R     | D2770EA | DS2770AE+ on Tape and Reel, Lead-Free                  |
| DS2770BE+T&R     | D2770EB | DS2770BE+ on Tape and Reel, Lead-Free                  |
| DS2770AE+025     | 2770EAR | TSSOP, 25mΩ Sense Res., 4.1V Charge Voltage, Lead-Free |
| DS2770BE+025     | 2770EBR | TSSOP, 25mΩ Sense Res., 4.2V Charge Voltage, Lead-Free |
| DS2770AE+025/T&R | 2770EAR | DS2770AE+025 on Tape and Reel, Lead-Free               |
| DS2770BE+025/T&R | 2770EBR | DS2770BE+025 on Tape and Reel, Lead-Free               |
| DS2770AE         | D2770EA | TSSOP, Ext. Sense Res., 4.1V Charge Voltage            |
| DS2770BE         | D2770EB | TSSOP, Ext. Sense Res., 4.2V Charge Voltage            |
| DS2770AE/T&R     | D2770EA | DS2770AE on Tape and Reel                              |
| DS2770BE/T&R     | D2770EB | DS2770BE on Tape and Reel                              |
| DS2770AE-025     | 2770EAR | TSSOP, 25mΩ Sense Res., 4.1V Charge Voltage            |
| DS2770BE-025     | 2770EBR | TSSOP, 25mΩ Sense Res., 4.2V Charge Voltage            |
| DS2770AE-025/T&R | 2770EAR | DS2770AE-025 on Tape and Reel                          |
| DS2770BE-025/T&R | 2770EBR | DS2770BE-025 on Tape and Reel                          |

**DESCRIPTION (CONTD.)**

The DS2770 provides a unique ID, a digital temperature sensor, an analog-to-digital converter (ADC) that measures battery voltage and current, an integrated current accumulator that keeps a running total of all current entering and leaving the battery, an elapsed time meter, NV memory for storage of important parameters, and an integrated charge controller supporting rechargeable lithium (including lithium-ion and lithium-ion polymer) and nickel metal hydride (NiMH) batteries. Current measurement can be accomplished through the use of an integrated 25mΩ sense resistor or through an external sense resistor. The resolution of the current, voltage, and temperature measurements is sufficient for process monitoring applications such as battery-charge control and safety. The charge-control technique is user-selectable to support either pulse charge for rechargeable lithium or dT/dt termination for NiMH. Additionally, programmable charge timers and low-battery recovery are provided for safety and convenience.

Information is sent to/from the DS2770 over a 1-Wire interface so that only one wire (and ground) needs to be connected from a processor to a DS2770. This means that DS2770-equipped battery packs need only four output connectors: battery power, charge source, ground, and the 1-Wire interface. Each device has a factory-programmed 64-bit net address that allows it to be individually addressed by the host system.

Two types of memory are provided on the DS2770 for battery information storage: lockable EEPROM and SRAM. EEPROM memory saves important battery data in true NV memory that is unaffected by severe battery depletion, accidental shorts, or ESD events and becomes ROM when locked to provide additional security for unchanging battery data. SRAM provides inexpensive storage for temporary data.

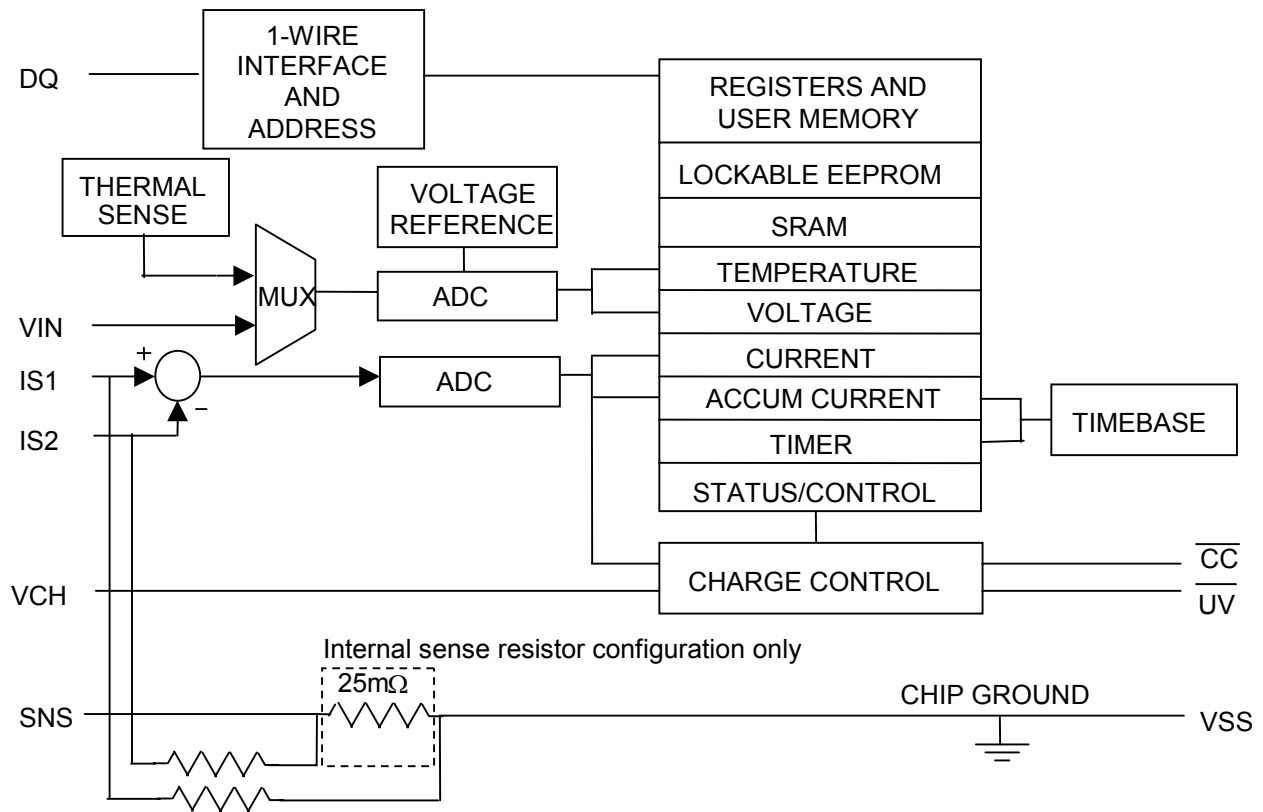
**BLOCK DIAGRAM** Figure 1

**DETAILED PIN DESCRIPTION Table 1**

| PIN        | SYMBOL          | DESCRIPTION   |
|------------|-----------------|---|
| 1          | $\overline{UV}$ | <b>Battery Undervoltage Detect Output:</b> This pin allows charge of the battery at a reduced rate when the battery cell voltage is less than the low battery voltage threshold, $V_{LB}$ . |
| 2          | $\overline{CC}$ | <b>Charge Control Output:</b> Charge of the battery is controlled through this pin when battery cell voltage is greater than or equal to $V_{LB}$ .   |
| 3          | VCH             | <b>Charge Supply Input:</b> The charge source is connected to this pin and is measured by the DS2770 to determine if a charge source is present.  |
| 4, 5, 6    | SNS             | <b>Sense Resistor Connection:</b> Connect to the negative terminal of the battery pack. In the internal sense resistor configuration, the sense resistor is connected between VSS and SNS.  |
| 8          | IS2             | <b>Current-Sense Input:</b> This pin is internally connected to SNS through a 10k $\Omega$ resistor. Connect a 0.1 $\mu$ F capacitor between IS2 and IS1 to complete a lowpass filter.      |
| 9          | IS1             | <b>Current-Sense Input:</b> This pin is internally connected to VSS through a 10k $\Omega$ resistor. Connect a 0.1 $\mu$ F capacitor between IS1 and IS2 to complete a lowpass filter.      |
| 11, 12, 13 | VSS             | <b>Device Ground:</b> Connect directly to the negative terminal of the battery cell. For the external sense resistor configuration, connect the sense resistor between VSS and SNS.         |
| 14         | DQ              | <b>Data Input/Out:</b> 1-Wire data line. Open-drain output driver. Connect this pin to the DATA terminal of the battery pack. Pin has an internal pull-down for sensing disconnection.      |
| 15         | VIN             | <b>Voltage Sense Input:</b> The voltage on the battery cell is monitored via this input pin.  |
| 16         | VDD             | <b>Power Supply Input:</b> Input supply voltage for the DS2770 (2.7V to 5.5V)   |
| 7, 10      | NC              | <b>Do not connect.</b>  |

**APPLICATION EXAMPLE Figure 2**

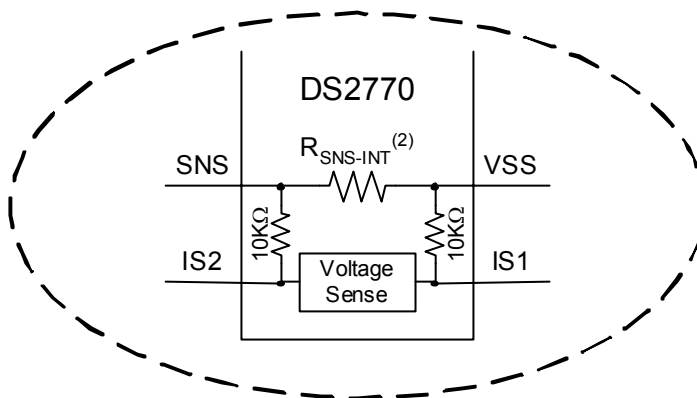
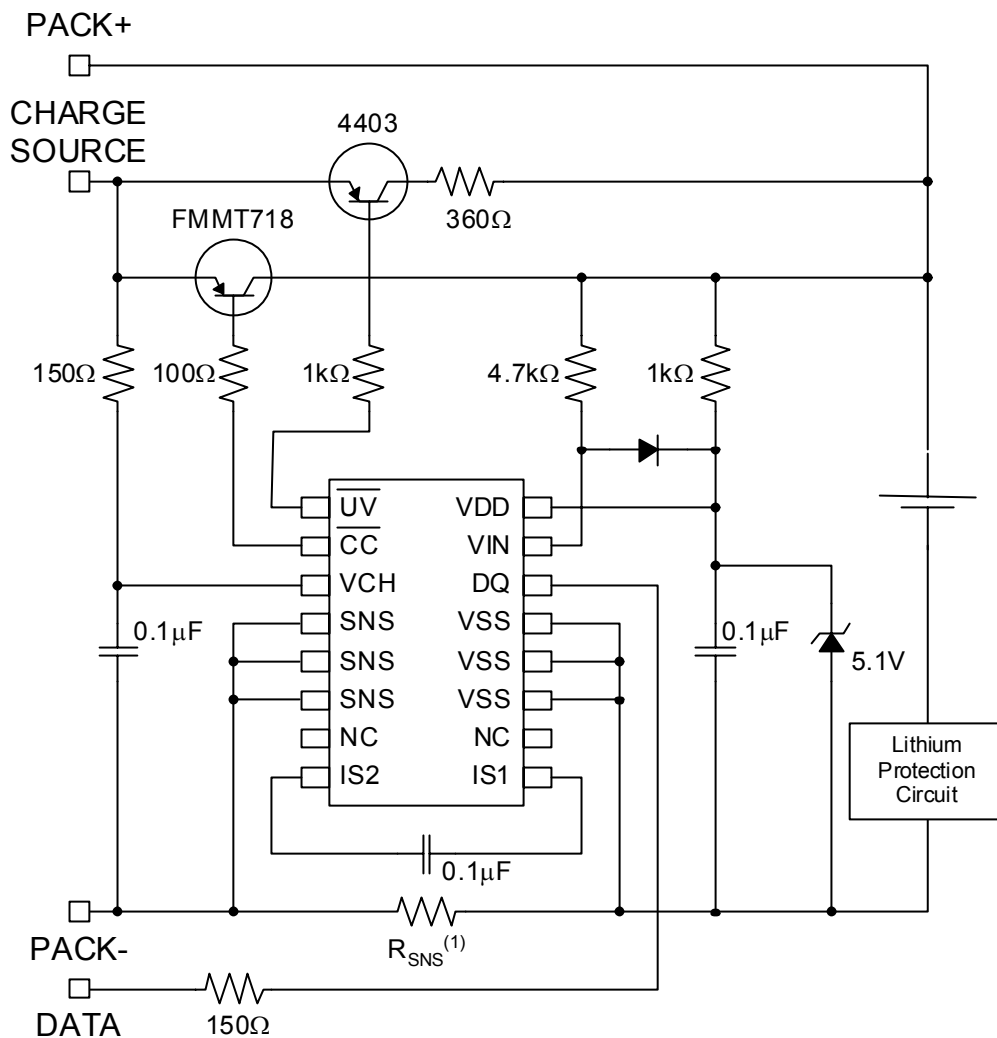

- 1 —  $R_{SNS}$  is present for external sense resistor configuration only.
- 2 —  $R_{SNS-INT}$  is present for internal sense resistor configuration only.

## POWER MODES

The DS2770 has two possible power modes: Active Mode and Sleep Mode. While in Active Mode, the DS2770 continually measures current, voltage, temperature, and time. Also, current flow is accumulated, charge control is provided, and data is available to the host system. In Sleep Mode, the DS2770 ceases these activities. The DS2770 can enter Sleep Mode only when the PMOD bit in the Status Register is set to 1 and the following other conditions occur:

- The CINI bit is set to 0 and the DQ line is held low for longer than two seconds. If a charge is in progress, charging will immediately stop and the device will begin transition to Sleep Mode.
- The CINI bit is set to 1 and the DQ line is held low for longer than two seconds. If a charge is in progress, the DS2770 will not go into Sleep Mode until the charge operation is completed.

The DS2770 returns to Active Mode when any of the following occurs:

- The DQ line is pulled high.
- The voltage on VCH becomes greater than VDD (charger connection) with the CINI bit set to 1.

Once the DS2770 identifies the 2 second DQ low condition, a transition to Sleep Mode begins. This process will take up to an additional 11 seconds before the supply current drops to  $I_{SLEEP}$  levels.

The DS2770 defaults to Active Mode when power is first applied to VDD.

## CHARGER FUNCTION

The DS2770 operates as a standalone charge controller supporting rechargeable lithium and NiMH battery technologies. The battery type to be charged is selectable through the CTYPE bit of the Status Register (0 for rechargeable lithium and 1 for NiMH). Charge control of both battery types is performed by on/off gating of an external constant current or current-limited charge source. If the battery voltage is less than  $V_{LB}$  and a charge source is present, pin  $\overline{UV}$  is driven low, signifying the need to recover the battery at a reduced rate before fast charging can begin. In Figure 2's application circuit,  $\overline{UV}$  gates a trickle-charge current limited by a  $360\Omega$  series resistor. Selection of this resistor depends on the characteristics of the charge source.  $\overline{UV}$  is driven low independent of any other state of the pack, including pack temperature and the status of the CINI bit.  $\overline{UV}$  is driven high when the battery voltage reaches  $V_{LB}$ . While trickle charging, a "charge in progress" status is indicated with (0, 1) values, respectively, in the CSTAT1 and CSTAT0 bits of the Status Register assuming any previous charge sequence completed status has been cleared.

Fast charging can be initiated by one of two methods:

- 1) Issuing a Start Charge command [B5h].
- 2) Introducing a charge supply on the VCH pin when the CINI bit in the Status Register is a 1.

Note that if VDD is below approximately 1.8V prior to using either initiation method, fast charge will not start after the battery is trickle charged to  $V_{LB}$ .

After initiation, the start of fast charge may be postponed if any of the following conditions exist:

- The temperature is outside the valid charge window specified by  $T_{CL}$  ( $0^{\circ}\text{C}$ ) and  $T_{CH}$  ( $40^{\circ}\text{C}$ ).
- Charge source is not present ( $VCH < VDD$ ).
- Conversion data is not valid (data becomes valid 110ms after waking from Sleep Mode).
- Battery voltage is less than the low-battery-voltage threshold,  $V_{LB}$ , (3.0V).

After initiation and clearing of the above conditions, fast charging begins with the  $\overline{CC}$  pin driven low. During fast charging,  $\overline{CC}$  remains low, except for periodic testing of premature charge source removal in which  $\overline{CC}$  is driven high for approximately 27 $\mu$ s every 55ms. As long as the charge source remains connected and the temperature remains in the valid range, charging will proceed per the method selected by the CTYPE bit. If the charge source is removed or the Stop Charge command [BEh] is issued,  $\overline{CC}$  is driven high and charging must be reinitiated by one of the two charge initiation methods described previously. Charging will also be stopped if the DQ line is low for >2s and the CINI bit is set to 0. Assuming any previous charge status has been cleared, a “charge in progress” status is indicated during fast charging with (0, 1) values, respectively, in the CSTAT1 and CSTAT0 bits of the Status Register.

Upon charge completion according to the method selected with the CTYPE bit, or completion due to either of the secondary methods, pin  $\overline{CC}$  will return to the high state, and a charge done condition will be flagged with (1, 1) values in the CSTAT1 and CSTAT0 bits of the Status Register. Note that the charge done status is latched and must be cleared by a write of any value to the Status Register. Once charging has been completed or aborted, the DS2770 may either enter the Sleep Mode or remain active, depending on the state of the PMOD bit described previously in the Power Modes section.

## RECHARGEABLE LITHIUM CHARGER OPERATION

Fast charging of lithium cell types is performed in two distinct regions. The bulk charge region delivers most of the charge to the cell by gating current from the charge source while the battery voltage is below the charge voltage threshold,  $V_{CV}$ . The  $\overline{CC}$  pin remains low, driving a PNP or P-channel MOSFET switch. When the battery voltage reaches  $V_{CV}$ , the pulse region begins in which a pulse-charge technique is employed that allows  $\overline{CC}$  to remain low for a delay period of  $t_{VCV}$  (875ms) after which  $\overline{CC}$  is driven high. When the battery voltage decays below  $V_{CV}$ ,  $\overline{CC}$  is again driven low and the cycle is repeated. The pulse region of charge continues with the  $\overline{CC}$  duty cycle slowly changing. Eventually, the battery voltage decay time, and thus the  $\overline{CC}$  high time, becomes longer than 13.125s, and charge is terminated. The charge decay time limit,  $t_{CD}$ , includes one 875ms period of  $\overline{CC}$  low and 15 periods high for a total time of 14s. The average charge rate at termination is 1/16 of the rate set by the charge source. See Figure 3 for an illustration of the  $t_{CD}$  decay method. See the Secondary Charge Termination section for the secondary termination means based on time or temperature included for increased safety.

## RECHARGEABLE LITHIUM PULSE CHARGING Figure 3

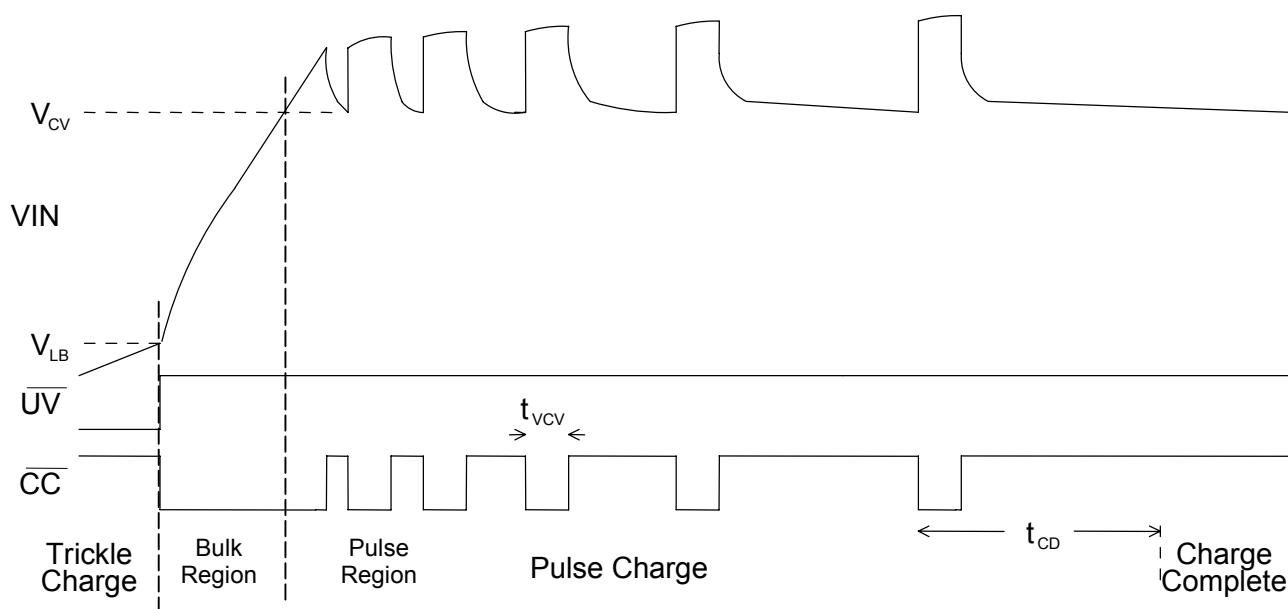

### NiMH CHARGER OPERATION

During NiMH charging, charge current from a constant current or current-limited supply is gated to the battery under control of  $\overline{UV}$  and  $\overline{CC}$  pins. Since the transition from trickle charge to fast charge occurs when the battery reaches 3.0V, a three-cell NiMH battery will begin fast charge at 1.0V per cell. A voltage divider can be used to adjust the transition point to a higher per cell voltage, though values in the Voltage Measurement Register would be affected by the divider ratio.

At the start of fast charge, the DS2770 uses the most recent temperature measurement to determine the appropriate  $dT/dt$  termination rate for the ambient conditions from Table 2 below. During the first 5 minutes, temperature rate termination is blanked to avoid false  $dT/dt$  detection due to  $I^2R$  heating. After the blanking period,  $dT/dt$  detection begins using one of the initial rates from Table 2 and requires that the rate of temperature rise continue at or above the selected rate for 2.8 minutes. Internally, values from the Temperature Measurement Register are averaged in determining the sustained rate of temperature rise. The effective rate shown in Table 2 is based on NiMH charge data and represents the predicted instantaneous  $dT/dt$  rate at termination.

### NiMH CHARGE TERMINATION THRESHOLDS Table 2

| AMBIENT TEMPERATURE (°C) | dT/dt THRESHOLD  |                    |
|--------------------------|------------------|--------------------|
|                          | INITIAL (°C/MIN) | EFFECTIVE (°C/MIN) |
| 0 to +5                  | 0.30             | 1.0                |
| +5 to +15                | 0.45             | 1.0                |
| +15 to +40               | 0.60             | 1.0                |

## SECONDARY CHARGE TERMINATION

Two secondary charge terminations are included. Independent of battery technology selection, charge terminates if the maximum charge temperature is exceeded or the charge timer expires. The CSTAT1 and CSTAT0 bits in the Status Register will both be set to 1 to indicate a “charge sequence completed” status.

The maximum temperature threshold,  $T_{MCT}$ , is fixed at +50°C. If the temperature measurement exceeds  $T_{MCT}$  during charge, the charge is terminated.

The maximum charge time is set in the Charge Time Register, CTR. CTR is initialized from lockable EEPROM location address 34h at the start of fast charge ( $\overline{CC}$  driven low after initiation). CTR decrements by one count every 56 seconds ( $t_{CTR}$ ) during fast charge. If CTR reaches zero, charging is terminated. Since CTR is writable, the value in CTR may be overwritten at any time during a charge to modify the maximum charge time. Figure 4 shows the format of CTR.

### CHARGE TIME REGISTER Figure 4

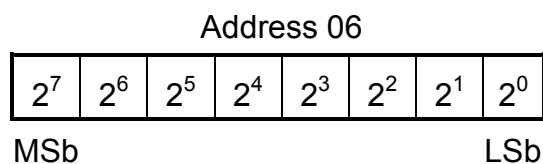

Units: 0.015625h

## CURRENT MEASUREMENT

In the Active Mode of operation, the DS2770 continually measures the current flow into and out of the battery by measuring the voltage drop across a current-sense resistor. The DS2770 is available in two configurations: 1) internal 25mΩ current-sense resistor; 2) external user-selectable sense resistor. In either configuration, the DS2770 considers the voltage difference between pins IS1 and IS2 ( $V_{IS} = V_{IS1} - V_{IS2}$ ) to be the filtered voltage drop across the sense resistor. A positive  $V_{IS}$  value indicates current is flowing into the battery (charging), while a negative  $V_{IS}$  value indicates current is flowing out of the battery (discharging). Note that when an external sense resistor is used, one end of the resistor must be wired directly to VSS (the negative terminal of the cell) for proper operation of the current measurement circuitry.

$V_{IS}$  is measured with a signed resolution of 15 bits. Measurements are updated in the Current Register in two’s complement format every 3.52 seconds. The Current Register value represents the average current over 3.52 seconds. Currents outside the register’s range are reported at the limit of the range. Figure 5 shows the format of the Current Register.

For the internal sense resistor configuration, the DS2770 maintains the Current Register in units of amps, with a resolution of 62.5μA and a full-scale range of ±2.048A. The DS2770 automatically compensates for internal sense resistor process variations and temperature effects when reporting current.

For the external sense resistor configuration, the DS2770 writes the measured  $V_{IS}$  voltage to the Current Register, with a resolution of 1.56μV and a full-scale range of ±51.2mV.

## CURRENT REGISTER FORMAT Figure 5

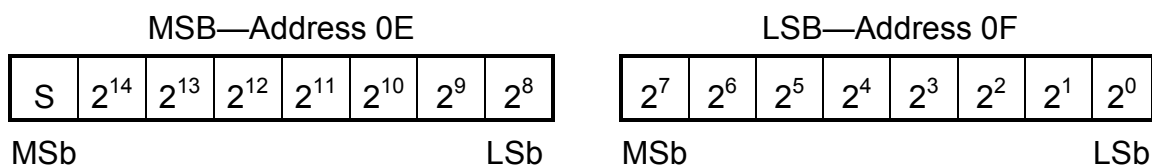

Units: 62.5 $\mu$ Ah for internal sense resistor  
1.56 $\mu$ Vh for external sense resistor

## CURRENT ACCUMULATORS

The current accumulator facilitates remaining capacity estimation by tracking the net current flow into and out of the battery. Current flow into the battery increments the current accumulator while current flow out of the battery decrements it. Data is maintained in the current accumulator in two's complement format and updated every 3.52s. Figure 6 the format of the current accumulator.

When the internal sense resistor is used, the DS2770 maintains the current accumulator in units of amp-hours, with a resolution of 250 $\mu$ A and full-scale range of  $\pm 8.19$ Ah. When using an external sense resistor, the DS2770 maintains the current accumulator in units of volt-hours, with a resolution of 6.25 $\mu$ Vh and a full-scale range of  $\pm 205$ mVh.

## ACCUMULATED CURRENT REGISTER FORMAT Figure 6

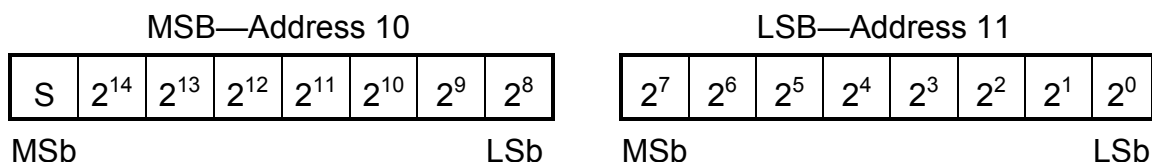

Units: 0.25mAh for internal sense resistor  
6.25 $\mu$ Vh for external sense resistor

## CURRENT OFFSET COMPENSATION

Current measurement and consequently the current accumulation are internally compensated for offset on a continual basis to minimize errors from variations in device temperature and supply voltage. Offset compensation is corrected to  $\pm 1$ LSB at least once per hour. Additionally, the Current Offset Bias Register provides a user-programmable constant bias value that may be used to correct for errors due to circuit layout or topology that result in current measurement or current accumulation errors. It can also be used to arbitrarily apply a constant bias to force the current measurement to be pessimistic, or correct for room temperature self-discharge. The current offset bias value is stored in EEPROM addresses 32h and 33h in two's complement format. The stored value is subtracted from each current measurement; therefore, positive values (0001h to 7fffh) bias the current measurement and current accumulation in the discharge direction. Figure 7 shows the format of the Current Offset Bias Register.

## CURRENT-OFFSET BIAS Figure 7

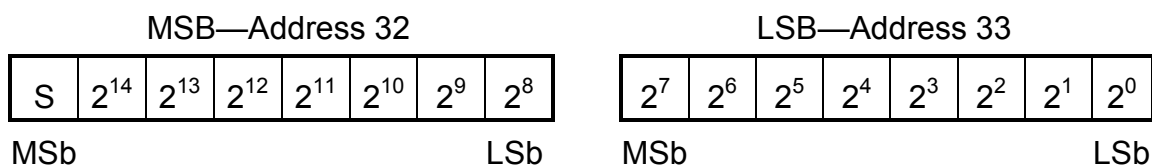

Units: 0.0625mA for internal sense resistor  
1.5625 $\mu$ V for external sense resistor

## VOLTAGE MEASUREMENT

The DS2770 continuously measures the voltage between pins VIN and VSS with a resolution of 4.88mV over a range of 0V to 4.992V. Measurement data is updated every 55ms and placed in the Voltage Register in two's complement format. Voltages above the maximum register value are reported as the maximum value. Figure 8 shows the Voltage Register format.

## VOLTAGE REGISTER FORMAT Figure 8

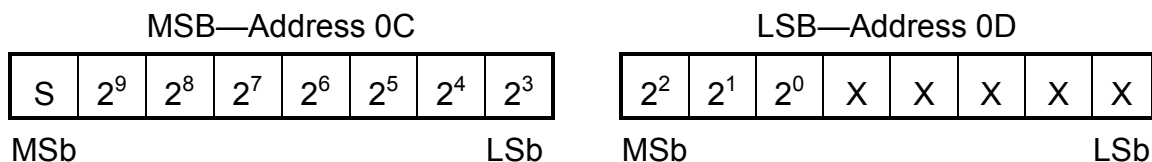

Units: 4.88mV

## TEMPERATURE MEASUREMENT

The DS2770 uses an integrated temperature sensor to continually measure battery temperature with a resolution of 0.125°C. Temperature measurements are updated every 55ms and placed in the Temperature Register in two's complement format. Figure 9 shows the Temperature Register format.

## TEMPERATURE REGISTER FORMAT Figure 9

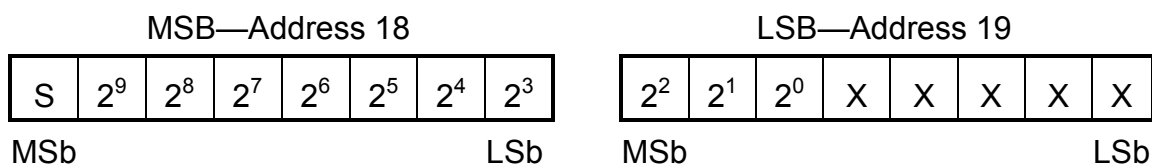

Units: 0.125°C

## TIMER

The DS2770 provides a general-purpose timer with a range of 1024h. The timer count is stored in the Elapsed Time Register with a resolution of approximately 56s. The count will roll over to zero when it reaches its maximum value and begin counting up again. Additionally, the user can write any desired value to the register. Figure 10 shows the Elapsed Time Register format.

## ELAPSED TIME REGISTER FORMAT Figure 10

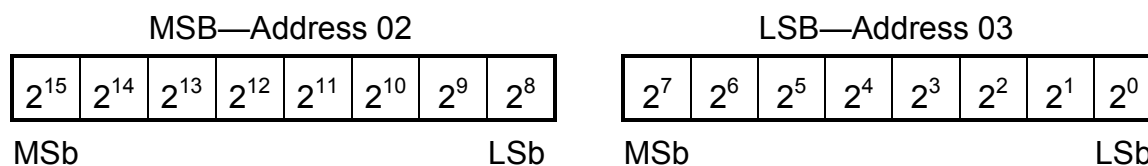

Units: 0.015625hr

## MEMORY

The DS2770 has a 256-byte linear address space with registers for instrumentation, status, and control in the lower 32 bytes, with lockable EEPROM and SRAM memory occupying portions of the remaining address space. All EEPROM and SRAM memory is general purpose except addresses 31h, 32h, 33h, and 34h, which should be written with the default values for the Status Register (31h), Current Offset Register (32h to 33h), and Charge Time Register (34h). When the MSB of any two-byte register is read, both the MSB and LSB are latched and held for the duration of the Read Data command to prevent updates during the read and ensure synchronization between two register bytes. For consistent results, always read the MSB and the LSB of a two-byte register during the same Read Data command sequence.

EEPROM memory is shadowed by RAM to eliminate programming delays between writes and to allow the data to be verified by the host system before being copied to EEPROM. All reads and writes to/from EEPROM memory actually access shadow RAM. In unlocked EEPROM blocks, the Write Data command updates shadow RAM. In locked EEPROM blocks, the Write Data command is ignored. The Copy Data command copies the contents of shadow RAM to EEPROM in an unlocked block of EEPROM, but has no effect on locked blocks. The Recall Data command copies the contents of a block of EEPROM to shadow RAM.

Lockable EEPROM is byte programmable and functions as EEPROM until reprogramming is disabled by the user. The lockable EEPROM can be locked in separate blocks and operate as general EEPROM until locked by the Lock command [6Axxh]. Reprogramming of the lockable EEPROM blocks is permanently disabled once the Lock command is used. Addresses 20 to 2Fh comprise a first 16-byte block, addresses 30 to 3Fh comprise a second 16-byte block, and addresses 40 to 47h comprise a third 8-byte block. Within the second block, address 31h holds the Status Register initialization data, addresses 32h and 33h hold the Current Offset Register, and address 34h holds the Charge Time Register initialization data. The Status Register initialization data is supplied to the Status Register in location address 01h on either a device power up or upon the execution of the Refresh command [63h]. The charge time initialization data is supplied to the Charge Time Register in address 06h upon the start of fast charge. The Status Register and the Charge Time Register are both initialized directly from the EEPROM and not from the shadow RAM. However, the current offset data is supplied directly from the shadow RAM. See the sections on the Status Register and the Charge Time Register for more detailed information. See the detailed Memory Map in Figure 11 for more information on the DS2770 memory.

**MEMORY MAP** Figure 11

| ADDRESS (HEX) | DESCRIPTION  | R/W  |
|---------------|--|------|
| 00            | Reserved   |      |
| 01            | Status Register  | R**  |
| 02            | Elapsed Time Register MSB  | R/W  |
| 03            | Elapsed Time Register LSB  | R/W  |
| 04 to 05      | Reserved   |      |
| 06            | Charge Time Register   | R/W  |
| 07            | EEPROM Register  | R/W  |
| 08 to 0B      | Reserved   |      |
| 0C            | Voltage Register MSB   | R    |
| 0D            | Voltage Register LSB   | R    |
| 0E            | Current Register MSB   | R    |
| 0F            | Current Register LSB   | R    |
| 10            | Accumulated Current Register MSB   | R/W  |
| 11            | Accumulated Current Register LSB   | R/W  |
| 12 to 17      | Reserved   |      |
| 18            | Temperature Register MSB   | R    |
| 19            | Temperature Register LSB   | R    |
| 1A to 1F      | Reserved   |      |
| 20 to 2F      | Lockable EEPROM Block 0  | R/W* |
| 30 to 3F      | Lockable EEPROM Block 1<br>(31 = Status Register Initialization)<br>(32 to 33 = Current Offset Register)<br>(34 = Charge Time Register Initialization) | R/W* |
| 40 to 47      | Lockable EEPROM Block 2  | R/W* |
| 48 to 7F      | Reserved   |      |
| 80 to 8F      | General-Purpose SRAM   | R/W  |
| 90 to FF      | Reserved   |      |

\* The lockable EEPROM address locations 20h through 47h are writeable until locked by using the Lock function command [6Axxh], after which it is read only.

\*\* The Status Register bits are read only. However, writing any byte value to the Status Register is required to clear a previous charge completion condition flagged with both CSTAT1, CSTAT0 bits set.

**STATUS REGISTER**

The default values for the Status Register are stored in lockable EEPROM in the corresponding bits of address 31h. These values in address location 31h are supplied directly to the Status Register (not from shadow RAM) on either a device power-up or upon execution of the Refresh command. Changes to the Status Register bits must be made to the EEPROM location 31h, and then use the Refresh command to recall the changes to the Status Register. Figure 12 shows the format of the Status Register. The function of each bit is described in detail in the following paragraphs.

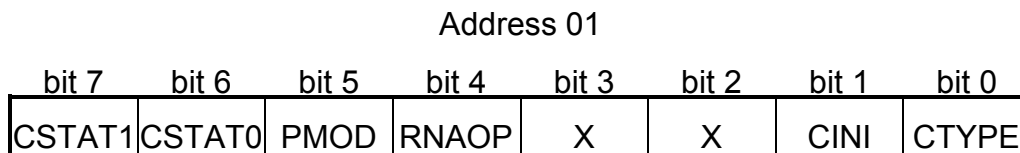
**STATUS REGISTER FORMAT** Figure 12

**CSTAT1, CSTAT0** — Charge Status. The CSTAT1 and CSTAT0 bits indicate the status of charge per the table below:

| CSTAT1 | CSTAT0 | STATUS                    |
|--------|--------|---------------------------|
| 0      | 0      | No charge source present  |
| 0      | 1      | Charge in progress        |
| 1      | 0      | Charge source is present  |
| 1      | 1      | Charge sequence completed |

The charge sequence complete state (1, 1) is present until cleared by a write to the Status Register.

**PMOD** — Sleep Mode Enable. A value of 1 in this bit enables the DS2770 to enter Sleep Mode when the DQ line goes low for greater than two seconds and leaves Sleep Mode when the DQ line goes high. A value of 0 disables DQ-related transitions into and out of Sleep Mode. The desired default value should be set in bit 5 of address location 31h. The factory default of the PMOD bit is 0.

**RNAOP** — Read Net Address Opcode. A value of 0 in this bit sets the opcode for the Read Net Address command to 33h, while a 1 sets the opcode to 39h. The desired default value should be set in bit 4 of address location 31h. The factory default of the RNAOP bit is 0.

**CINI** — Charge Initiation Select. The CINI bit is used to determine the method of charge initiation that will be allowed. A value of 0 indicates that charge may be started only upon use of the Start Charge [B5h] command. A value of 1 indicates that charge may be started by either the Start Charge command, or by the application of a charge source at the charge supply input pin, VCH. The desired default value should be set in bit 1 of address location 31h. The factory default of the CINI bit is 0.

**CTYPE** — Charge Type. The charge type bit indicates the Charge Mode that will be used during charging. A 1 selects NiMH charger operation and a 0 selects rechargeable lithium charger operation. The desired default value should be set in bit 0 of address location 31h. It is suggested that the EEPROM block containing the Status Register initiation (location 31h) be locked once the CTYPE and other Status Register bits are configured to avoid any possible unintended alterations during use. The factory default of the CTYPE bit is 0.

**X** — Reserved Bits.

## EEPROM REGISTER

Figure 13 shows the format of the EEPROM Register. The function of each bit is described in detail in the following paragraphs.

### EEPROM REGISTER FORMAT Figure 13

| Address 07 |       |       |       |       |       |       |       |
|------------|-------|-------|-------|-------|-------|-------|-------|
| bit 7      | bit 6 | bit 5 | bit 4 | bit 3 | bit 2 | bit 1 | bit 0 |
| EEC        | LOCK  | X     | X     | X     | BL2   | BL1   | BL0   |

**EEC** — EEPROM Copy Flag. A 1 in this read-only bit indicates that a Copy Data command is in progress. While this bit is high, writes to EEPROM addresses are ignored. A 0 in this bit indicates that data may be written to unlocked EEPROM blocks.

**LOCK** — EEPROM Lock Enable. This bit is used to enable the Lock command by writing a 1 to it prior to issuing the command. When this bit is 0, the Lock command is ignored. After the Lock command is executed, the Lock bit is reset to 0. The Lock bit will also be reset by any other command issued after the bit has been set. The factory default is 0.

**BL2** — EEPROM Block 2 Lock Flag. A 1 in this read-only bit indicates that EEPROM Block 2 (addresses 40 to 47h) is locked (read-only) while a 0 indicates Block 2 is unlocked (read/write).

**BL1** — EEPROM Block 1 Lock Flag. A 1 in this read-only bit indicates that EEPROM Block 1 (addresses 30 to 3Fh) is locked (read-only) while a 0 indicates Block 1 is unlocked (read/write).

**BL0** — EEPROM Block 0 Lock Flag. A 1 in this read-only bit indicates that EEPROM Block 0 (addresses 20 to 2Fh) is locked (read-only) while a 0 indicates Block 0 is unlocked (read/write).

**X** — Reserved Bits.

## 1-WIRE BUS SYSTEM

The 1-Wire bus is a system that has a single bus master and one or more slaves. A multidrop bus is a 1-Wire bus with multiple slaves. A single-drop bus has only one slave device. In all instances, the DS2770 is a slave device. The bus master is typically a microprocessor in the host system. The discussion of this bus system consists of four topics: 64-bit Net Address, Hardware Configuration, Transaction Sequence, and 1-Wire Signaling.

## 64-BIT NET ADDRESS

Each DS2770 has a unique factory-programmed 1-Wire net address that is 64 bits in length. The first eight bits are the 1-Wire family code (2Eh for DS2770). The next 48 bits are a unique serial number. The last eight bits are a CRC of the first 56 bits (see Figure 14). The 64-bit net address and the 1-Wire I/O circuitry built into the device enable the DS2770 to communicate through the 1-Wire protocol detailed in the 1-Wire Bus System section of this data sheet.

## NET ADDRESS FORMAT Figure 14

|           |                      |                         |
|-----------|----------------------|-------------------------|
| 8-Bit CRC | 48-Bit Serial Number | 8-Bit Family Code (2Eh) |
|-----------|----------------------|-------------------------|

### CRC GENERATION

The DS2770 has an 8-bit CRC stored in the most significant byte of its 64-bit net address. To ensure error-free transmission of the address, the host system can compute a CRC value from the first 56 bits of the address and compare it to the CRC from the DS2770. The host system is responsible for verifying the CRC value and taking action as a result. The DS2770 does not compare CRC values and does not prevent a command sequence from proceeding as a result of a CRC mismatch. Proper use of the CRC can result in a communication channel with a very high level of integrity.

The 1-Wire CRC can be generated by the host using a circuit consisting of a Shift Register and XOR gates as shown in Figure 15, or it can be generated in software. Additional information about the Dallas 1-Wire Cyclic Redundancy Check is available in *Application Note 27, Understanding and Using Cyclic Redundancy Checks with Dallas Semiconductor Touch Memory Products*.

In Figure 15, the Shift Register bits are initialized to 0. Then, starting with the least significant bit of the family code, one bit at a time is shifted in. After the 8<sup>th</sup> bit of the family code has been entered, the serial number is entered. After the 48<sup>th</sup> bit of the serial number has been entered, the Shift Register contains the CRC value.

### 1-WIRE CRC GENERATION BLOCK DIAGRAM Figure 15

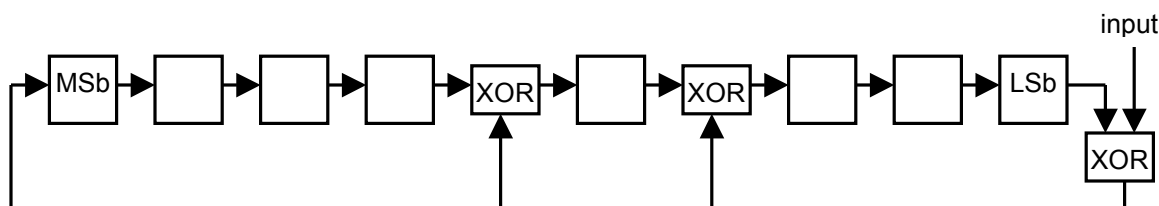

### HARDWARE CONFIGURATION

Because the 1-Wire bus has only a single line, it is important that each device on the bus be able to drive it at the appropriate time. To facilitate this, each device attached to the 1-Wire bus must connect to the bus with open-drain or tristate output drivers. The DS2770 uses an open-drain output driver as part of the bidirectional interface circuitry shown in Figure 16. If a bidirectional pin is not available on the bus master, separate output and input pins can be tied together.

The 1-Wire bus must have a pull-up resistor at the bus-master end of the bus. For short line lengths, the value of this resistor should be approximately 5k $\Omega$ . The idle state for the 1-Wire bus is high. If, for any reason, a bus transaction must be suspended, the bus must be left in the idle state in order to properly resume the transaction later. If the bus is left low for more than 120 $\mu$ s, slave devices on the bus begin to interpret the low period as a reset pulse, effectively terminating the transaction.

## 1-WIRE BUS INTERFACE CIRCUITRY Figure 16

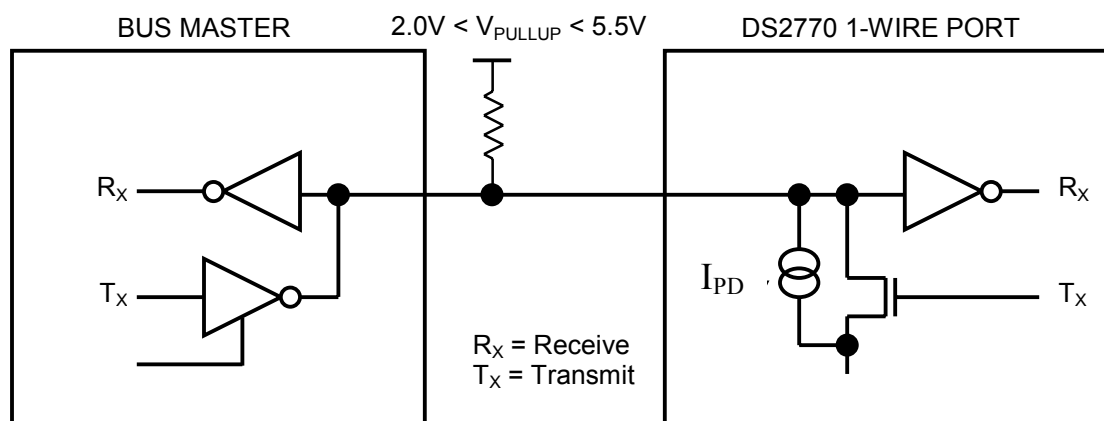

### TRANSACTION SEQUENCE

The protocol for accessing the DS2770 through the 1-Wire port is as follows:

- Initialization
- Net Address command
- Function command
- Transaction/Data

The sections that follow describe each of these steps in detail.

All transactions of the 1-Wire bus begin with an initialization sequence consisting of a reset pulse transmitted by the bus master followed by a presence pulse simultaneously transmitted by the DS2770 and any other slaves on the bus. The presence pulse tells the bus master that one or more devices are on the bus and ready to operate. For more details, see the 1-Wire Signaling section.

### NET ADDRESS COMMANDS

Once the bus master has detected the presence of one or more slaves, it can issue one of the five Net Address commands described in the following paragraphs. The name of each Net Address command is followed by the 8-bit opcode for that command in square brackets. Figure 17 presents a transaction flowchart of the five Net Address commands.

**Read Net Address [33h or 39h].** This command allows the bus master to read the DS2770's 1-Wire net address. This command can only be used if there is a single slave on the bus. If more than one slave is present, a data collision occurs when all slaves try to transmit at the same time (open drain produces a wired-AND result). The RNAOP bit in the Status Register selects the opcode for this command, with RNAOP = 0 indicating 33h and RNAOP = 1 indicating 39h.

**Match Net Address [55h].** This command, followed by a 64-bit net address, allows the bus master to specifically address one DS2770 on the 1-Wire bus. Only the DS2770 that exactly matches the 64-bit address responds to the subsequent Function command. All other slaves ignore the Function command and wait for a reset pulse. This command can be used with one or more slave devices on the bus.

**Skip Net Address [CCh].** This command saves time when there is only one DS2770 on the bus by allowing the bus master to issue a Function command without specifying the net address of the slave. If more than one slave device is present on the bus, a subsequent Function command can cause a data collision when all slaves transmit data at the same time.

**Search Net Address [F0h].** This command allows the bus master to use a process of elimination to identify the net addresses of all slave devices on the bus. The search process involves the repetition of a simple three-step routine: read a bit, read the complement of the bit, then write the desired value of that bit. The bus master performs this simple three-step routine on each bit of the net address. After one complete pass through all 64 bits, the bus master knows the address of one device. The remaining devices can then be identified on additional passes. See Chapter 5 of *The Book of DS19xx iButton Standards* for a comprehensive discussion of a net address search, including an actual example. The Search Net Address algorithm cannot be used with the DS2770 in multi-drop applications with any 1-Wire devices that have either a 6h or Eh as the LS byte of the 1-Wire family code. Because the 1-Wire family code of the DS2770 is 2Eh, Search Net Address cannot be used to ascertain the 64-bit serial numbers of multiple DS2770's on a single bus. If an application does require two DS2770 to share a common bus, the bus master may determine the serial numbers of each device using the Read Net Address function, with one part configured to respond to the 33h command (RNAOP = 0) and the other the 39h command (RNAOP = 1).

**Resume [A5h].** This command is used to speed data throughput in multidrop environments where the DS2770 needs to be accessed several times. The DS2770 contains an internal flag that, when set, directly transfers control to the memory function commands upon receipt of a Resume command, similar to the Skip Net Address command. The only way the internal flag is set is through successfully executing the Match Net Address command or Search Net Address command. Once the flag is set, the device can repeatedly be accessed through the Resume command function. Accessing another device on the bus will clear the flag, thus preventing two or more devices from simultaneously responding to the Resume command function.

## FUNCTION COMMANDS

After successfully completing one of the five Net Address commands, the bus master can access the features of the DS2770 with any of the Function commands described in the following paragraphs. The name of each function is followed by the 8-bit opcode for that command in square brackets.

**Read Data [69h, XX].** This command reads data from the DS2770 starting at memory address XX. The LSb of the data in address XX is available to be read immediately after the MSb of the address has been entered. Because the address is automatically incremented after the MSb of each byte is received, the LSb of the data at address XX+1 is available to be read immediately after the MSb of the data at address XX. If the bus master continues to read beyond address FFh, the DS2770 will start over at address 00h. Addresses labeled “reserved” in the memory map contain undefined data. The Read Data command may be terminated by the bus master with a reset pulse at any bit boundary.

**Write Data [6Ch, XX].** This command writes data to the DS2770 starting at memory address XX. The LSB of the data to be stored at address XX can be written immediately after the MSb of the address has been entered. Because the address is automatically incremented after the MSb of each byte written, the LSB to be stored at address XX+1 can be written immediately after the MSb to be stored at address XX. If the bus master continues to write beyond address FFh, the DS2770 will start over-writing at address 00h. Writes to read-only addresses, reserved addresses, and locked EEPROM blocks are ignored. Incomplete bytes are not written. Writes to unlocked EEPROM blocks are to shadow RAM rather than EEPROM. See the Memory section for more details.

**Copy Data [48h, XX].** This command copies the contents of shadow RAM to EEPROM for the EEPROM block beginning with address XX (20h for block 0, 30h for block 1, and 40h for block 2). Copy Data commands that address locked blocks are ignored. While the Copy Data command is executing, the EEC bit in the EEPROM Register is set to 1 and writes to EEPROM addresses are ignored. Reads and writes to non-EEPROM addresses can still occur while the copy is in progress. The Copy Data command takes  $t_{EEC}$  time to execute.

**Recall Data [B8h, XX].** This command recalls the contents of the EEPROM block containing the first address location found in the block to shadow RAM.

**Lock [6Ah, XX].** This command locks (write-protects) blocks of EEPROM whose first memory location is XX (20h for block 0, 30h for block 1, and 40h for block 2). The Lock bit in the EEPROM Register must be set to 1 before the Lock command is executed. The Lock command must be the next command issued (after the 1-Wire reset) once the Lock bit has been set. If the Lock bit is 0, the Lock command has no effect. The Lock command is permanent; a locked block can never be written again. The Lock command takes  $t_{EEC}$  time to execute.

**Refresh [63h].** The Refresh command restores the Status Register initialization data stored in address location 31h to the Status Register. The Status Register is initialized directly from the EEPROM and not from the shadow RAM.

**Start Charge [B5h].** The Start Charge command is used to initiate charge through the host interface.

**Stop Charge [BEh].** The Stop Charge command is used to terminate charge through the host interface.

ROM COMMAND FLOW CHART Figure 17

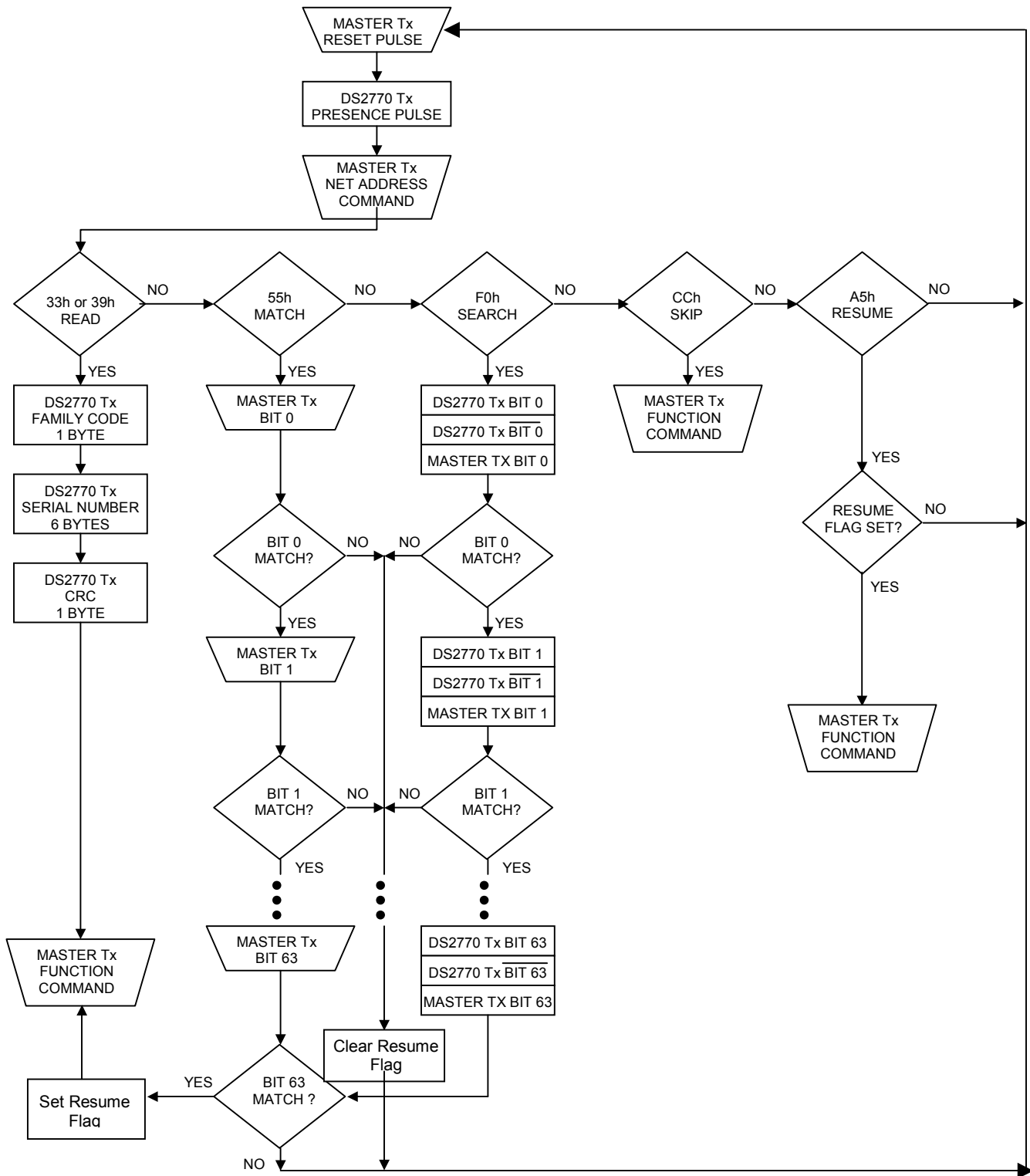

**FUNCTION COMMANDS Table 3**

| <b>COMMAND</b> | <b>DESCRIPTION</b>   | <b>COMMAND PROTOCOL</b> | <b>BUS STATE AFTER COMMAND PROTOCOL</b> | <b>BUS DATA</b> |
|----------------|--|-------------------------|---|-----------------|
| Read Data      | Reads data from memory map starting at address XX  | 69h, XX                 | Master R <sub>X</sub>                   | Unlimited       |
| Write Data     | Writes data to memory starting at address XX   | 6Ch, XX                 | Master Tx                               | Unlimited       |
| Copy Data      | Copies shadow RAM data to EEPROM block that begins with address location XX                | 48h, XX                 | Master Reset                            | None            |
| Recall Data    | Recalls EEPROM block that begins with address location XX to shadow RAM                    | B8h, XX                 | Master Reset                            | None            |
| Lock           | Permanently locks the block of lockable EEPROM memory that begins with address location XX | 6Ah, XX                 | Master Reset                            | None            |
| Refresh        | Restores Status Register initialization data   | 63h                     | Master Reset                            | None            |
| Start Charge   | Initiates charge through the host interface.   | B5h                     | Master Reset                            | None            |
| Stop Charge    | Terminates charge through the host interface.  | BEh                     | Master Reset                            | None            |

## I/O SIGNALING

The 1-Wire bus requires strict signaling protocols to insure data integrity. The DS2770 uses the following four protocols: the initiation sequence (reset pulse followed by presence pulse), Write 0, Write 1, and Read Data. All of these types of signaling except the presence pulse are initiated by the bus master.

Figure 18 shows the initialization sequence required to begin any communication with the DS2770. A presence pulse following a reset pulse indicates the DS2770 is ready to accept a Net Address command. The bus master transmits (T<sub>X</sub>) a reset pulse for t<sub>RSTL</sub>. The bus master then releases the line and goes into Receive Mode (R<sub>X</sub>). The 1-Wire bus line is then pulled high by the pull-up resistor. After detecting the rising edge on the DQ pin, the DS2770 waits for the t<sub>PDH</sub> and then transmits the presence pulse for t<sub>PDL</sub>.

## 1-WIRE INITIALIZATION SEQUENCE (RESET PULSE AND PRESENCE PULSE) Figure 18

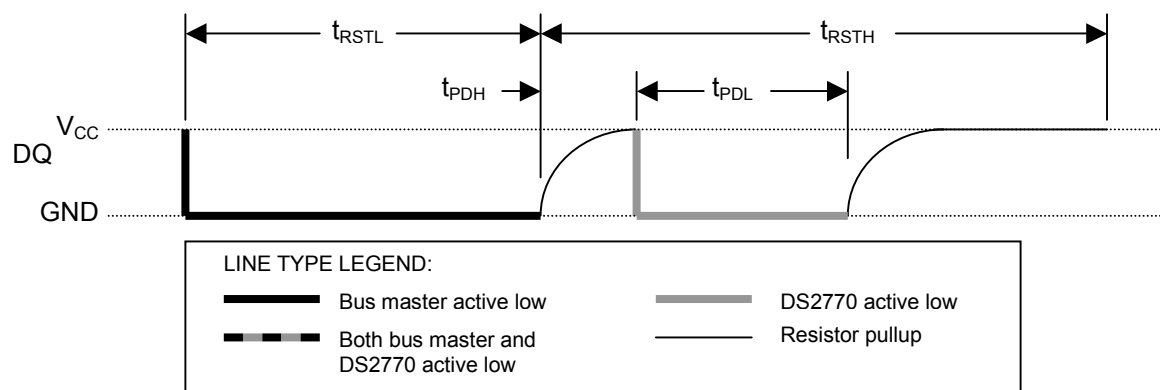

### WRITE TIME SLOTS

A write time slot is initiated when the bus master pulls the 1-Wire bus from a logic high (inactive) level to a logic low level. There are two types of write time slots: Write 1 and Write 0. All write time slots must be  $t_{SLOT}$  (60 $\mu$ s to 120 $\mu$ s) in duration with a 1 $\mu$ s minimum recovery time,  $t_{REC}$ , between cycles. The DS2770 samples the 1-Wire bus line between 15 $\mu$ s and 60 $\mu$ s after the line falls. If the line is high when sampled, a Write 1 occurs. If the line is low when sampled, a Write 0 occurs (see Figure 19). For the bus master to generate a Write 1 time slot, the bus line must be pulled low and then released, allowing the line to be pulled high within 15 $\mu$ s after the start of the write time slot. For the host to generate a Write 0 time slot, the bus line must be pulled low and held low for the duration of the write time slot.

### READ TIME SLOTS

A read time slot is initiated when the bus master pulls the 1-Wire bus line from a logic high level to logic low level. The bus master must keep the bus line low for at least 1 $\mu$ s and then release it to allow the DS2770 to present valid data. The bus master can then sample the data  $t_{RDV}$  (15 $\mu$ s) from the start of the read time slot. By the end of the read time slot, the DS2770 releases the bus line and allows it to be pulled high by the external pull-up resistor. All read time slots must be  $t_{SLOT}$  (60 $\mu$ s to 120 $\mu$ s) in duration with a 1 $\mu$ s minimum recovery time,  $t_{REC}$ , between cycles. See Figure 19 for more information.

# 1-WIRE WRITE AND READ TIME SLOTS Figure 19

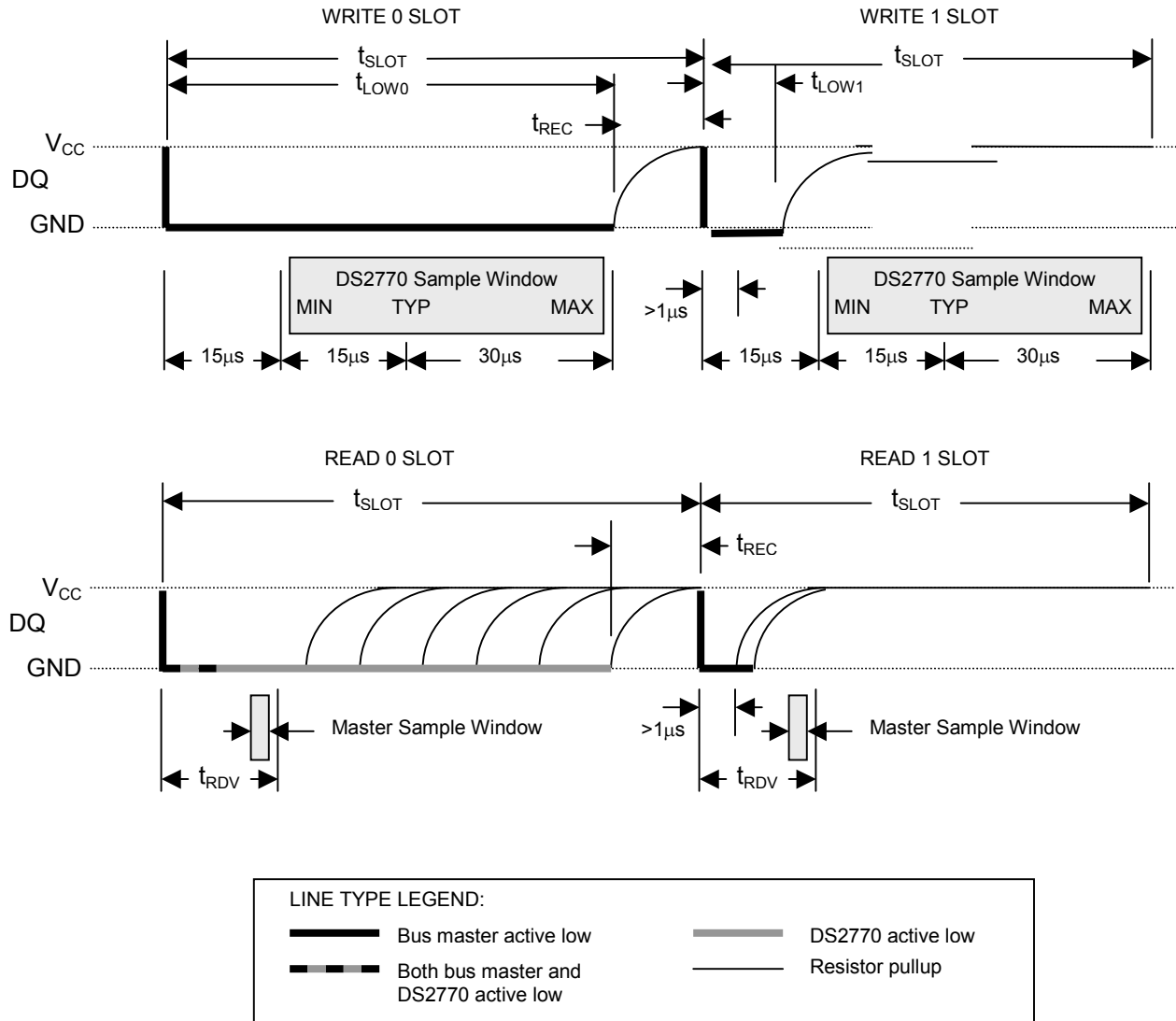

**ABSOLUTE MAXIMUM RATINGS\***

|   |  |
|---|--|
| Voltage on VIN, Relative to Ground                | -0.3V to $V_{DD} + 0.3V$               |
| Voltage on VCH, $\overline{CC}$ , $\overline{UV}$ | -0.3V to +18V                          |
| Voltage on Any Other Pin, Relative to Ground      | -0.3V to +6V                           |
| Current Max Iol $\overline{CC}$ , $\overline{UV}$ | 20mA                                   |
| Continuous Internal Sense Current                 | ±2.5A                                  |
| Pulsed Internal Sense Current                     | ±50A for <100µs/sec, <1000 pulses      |
| Operating Temperature Range                       | -40°C to +85°C                         |
| Storage Temperature Range                         | -55°C to +125°C                        |
| Soldering Temperature                             | See IPC/JEDEC J-STD-020A Specification |

\* This is a stress rating only and functional operation of the device at these or any other conditions above those indicated in the operation sections of this specification is not implied. Exposure to absolute maximum rating conditions for extended periods of time may affect reliability.

**RECOMMENDED DC OPERATING CONDITIONS**(-20°C to +70°C,  $2.7V \leq V_{DD} \leq 5.5V$ )

| PARAMETER      | SYMBOL   | MIN  | TYP | MAX | UNITS | NOTES |
|----------------|----------|------|-----|-----|-------|-------|
| Supply Voltage | $V_{DD}$ | 2.7  |     | 5.5 | V     | 1     |
| Data Pin       | DQ       | -0.3 |     | 5.5 | V     | 1     |

**DC ELECTRICAL CHARACTERISTICS**(-20°C to +70°C,  $2.7V \leq V_{DD} \leq 5.5V$ )

| PARAMETER                   | SYMBOL       | CONDITION                            | MIN | TYP | MAX | UNITS | NOTES |
|-----------------------------|--------------|--------------------------------------|-----|-----|-----|-------|-------|
| Supply Current, Sleep Mode  | $I_{SLEEP}$  | DQ = 0,<br>no activity               |     | 0.5 | 1   | µA    | 9     |
| Supply Current, Active Mode | $I_{ACTIVE}$ | DQ = 1,<br>normal operation          |     | 80  | 120 | µA    | 9     |
| VCH Input Current           | $I_{VCH}$    | VCH = 5V                             |     | 100 | 150 | µA    | 9     |
| DQ Input Logic High         | $V_{IH}$     |                                      | 1.5 |     |     | V     | 1     |
| DQ Input Logic Low          | $V_{IL}$     |                                      |     |     | 0.4 | V     | 1     |
| DQ Input Pull-Down Current  | $I_{PD}$     | $V_{DD} = 4.1V,$<br>$V_{DQ} = 0.4V.$ |     | 0.5 |     | µA    |       |
|                             |              | $V_{DD} = 5.5V,$<br>$V_{DQ} = 5.5V$  |     |     | 5   |       |       |
| Input Resistance, Pins VIN  | $R_{IN}$     |                                      | 15  |     |     | MΩ    |       |
| DQ Output Logic Low         | $V_{OL}$     | $I_{OL} = 4mA$                       |     |     | 0.4 | V     | 1     |

|                                   |             |                    |    |              |    |            |    |
|-----------------------------------|-------------|--------------------|----|--------------|----|------------|----|
| $\overline{UV}$ Output Low        | $I_{OL,UV}$ | $V_{UV} = 2V$      | 5  | 10           |    | mA         | 11 |
| $\overline{UV}$ Output High       | $V_{OH,UV}$ | $I_{UV} = 10\mu A$ |    | $V_P - 0.5V$ |    |            | 10 |
| $\overline{CC}$ Output Low        | $I_{OL,CC}$ | $V_{CC} = 2V$      | 5  | 10           |    | mA         | 11 |
| $\overline{CC}$ Output High       | $V_{OH,CC}$ | $I_{CC} = 10\mu A$ |    | $V_P - 0.5V$ |    |            | 10 |
| Internal Current-Sense Resistance | $R_{SNS}$   | $T_A = 25^\circ C$ | 20 | 25           | 30 | m $\Omega$ |    |
| DQ Low to $I_{SLEEP}$ time        | $t_{SLP}$   |                    | 5  |              | 13 | s          |    |

**ELECTRICAL CHARACTERISTICS:****TEMPERATURE, VOLTAGE, CURRENT** $(0^\circ C \text{ to } 50^\circ C, 2.7V \leq V_{DD} \leq 4.5V)$ 

| PARAMETER                      | SYMBOL     | CONDITION | MIN | TYP     | MAX     | UNITS      | NOTES     |
|--------------------------------|------------|-----------|-----|---------|---------|------------|-----------|
| Temperature Resolution         | $T_{LSB}$  |           |     | 0.125   |         | $^\circ C$ |           |
| Temperature Error              | $T_{ERR}$  |           |     |         | $\pm 3$ | $^\circ C$ | 2         |
| Voltage Resolution             | $V_{LSB}$  |           |     | 4.88    |         | mV         |           |
| Voltage Full Scale             | $V_{FS}$   |           |     | 5       |         | V          |           |
| Voltage Offset Error           | $V_{OERR}$ |           |     |         | 1       | LSb        |           |
| Voltage Gain Error             | $V_{GERR}$ |           |     |         | $\pm 1$ | % $V_{FS}$ |           |
| Current Resolution             | $I_{LSB}$  |           |     | 62.5    |         | $\mu A$    | 3, 13     |
|                                |            |           |     | 1.56    |         | $\mu V$    | 4, 13     |
| Current Full Scale             | $I_{FS}$   |           |     | 2.048   |         | A          | 3, 12, 13 |
|                                |            |           |     | 51.2    |         | mV         | 4, 12, 13 |
| Current Offset Error           | $I_{OERR}$ |           |     |         | $\pm 1$ | LSb        |           |
| Current Gain Error             | $I_{GERR}$ |           |     |         | $\pm 3$ | %          | 3, 7      |
|                                |            |           |     |         | $\pm 1$ |            | 4         |
| Accumulated Current Resolution | $q_{CA}$   |           |     | 250     |         | $\mu Ahr$  | 3, 13     |
|                                |            |           |     | 6.25    |         | $\mu Vhr$  | 4, 13     |
| Timebase Accuracy              | $t_{ERR}$  |           |     | $\pm 1$ | $\pm 3$ | %          | 5         |

## EEPROM RELIABILITY SPECIFICATION

(-20°C to 70°C, 2.7V ≤ V<sub>DD</sub> ≤ 5.5V)

| PARAMETER             | SYMBOL           | CONDITION | MIN    | TYP | MAX | UNITS  | NOTES |
|-----------------------|------------------|-----------|--------|-----|-----|--------|-------|
| Copy to EEPROM Time   | t <sub>EEC</sub> |           |        | 5   | 10  | ms     |       |
| EEPROM Copy Endurance | N <sub>EEC</sub> |           | 25,000 |     |     | cycles | 8     |

## ELECTRICAL CHARACTERISTICS:

### CHARGER FUNCTION

(0°C to 50°C, 2.7V ≤ V<sub>DD</sub> ≤ 5.5V)

| PARAMETER  | SYMBOL           | CONDITION | MIN | TYP        | MAX | UNITS | NOTES |
|--|------------------|-----------|-----|------------|-----|-------|-------|
| Low Battery Voltage Threshold                      | V <sub>LB</sub>  |           |     | 3.0        |     | V     | 1     |
| Pulse Charging Voltage Threshold                   | V <sub>CV</sub>  |           |     | 4.1<br>4.2 |     | V     | 1,6   |
| Lower Valid Charging Temperature Threshold         | T <sub>CL</sub>  |           |     | 0          |     | °C    |       |
| Upper Valid Charging Temperature Threshold         | T <sub>CH</sub>  |           |     | +40        |     | °C    |       |
| Maximum Charging Temperature Termination Threshold | T <sub>MCT</sub> |           |     | +50        |     | °C    |       |
| Overcharge Time                                    | t <sub>VCV</sub> |           |     | 875        |     | ms    |       |
| Charge Done Timer                                  | t <sub>CD</sub>  |           |     | 14         |     | s     |       |

**ELECTRICAL CHARACTERISTICS:****1-WIRE INTERFACE**(-20°C to 70°C, 2.7V ≤ V<sub>DD</sub> ≤ 5.5V)

| PARAMETER            | SYMBOL            | CONDITION | MIN | TYP | MAX | UNITS | NOTES |
|----------------------|-------------------|-----------|-----|-----|-----|-------|-------|
| Time Slot            | t <sub>SLOT</sub> |           | 60  |     | 120 | μs    |       |
| Recovery Time        | t <sub>REC</sub>  |           | 1   |     |     | μs    |       |
| Write 0 Low Time     | t <sub>LOW0</sub> |           | 60  |     | 120 | μs    |       |
| Write 1 Low Time     | t <sub>LOW1</sub> |           | 1   |     | 15  | μs    |       |
| Read Data Valid      | t <sub>RDV</sub>  |           |     |     | 15  | μs    |       |
| Reset Time High      | t <sub>RSTH</sub> |           | 480 |     |     | μs    |       |
| Reset Time Low       | t <sub>RSTL</sub> |           | 480 |     | 960 | μs    |       |
| Presence Detect High | t <sub>PDH</sub>  |           | 15  |     | 60  | μs    |       |
| Presence Detect Low  | t <sub>PDL</sub>  |           | 60  |     | 240 | μs    |       |
| DQ Capacitance       | C <sub>DQ</sub>   |           |     |     | 25  | pF    |       |

**NOTES**

- 1) All voltages are referenced to ground.
- 2) Self-heating due to output pin loading; sense resistor power dissipation will alter the reading from ambient conditions.
- 3) Using the internal current-sense resistor.
- 4) Using an external current-sense resistor.
- 5) Typical value for t<sub>ERR</sub> is at 3.6V and +25°C.
- 6) See Ordering Information section of data sheet to determine corresponding part number for each V<sub>CV</sub> value.
- 7) This specification includes the effects of temperature on the sense resistor. The DS2770 compensates for the internal sense resistor's temperature coefficient of 3700ppm/°C to an accuracy of ±500ppm/°C. The DS2770 does not attempt to compensate for the characteristics of an external sense resistor. Error terms arising from the use of an external sense resistor should be taken into account when calculating total current measurement error.
- 8) Four-year data retention at +70°C.
- 9) I<sub>SLEEP</sub>, I<sub>ACTIVE</sub> and I<sub>VCH</sub> are measured with the  $\overline{CC}$  and  $\overline{UV}$  pins floating.
- 10) V<sub>P</sub> is the greater of V<sub>DD</sub> or V<sub>CH</sub>. V<sub>OH,CC</sub> and V<sub>OH,UV</sub> test conditions: V<sub>DD</sub> = 5.5, V<sub>CH</sub> = 5.7V
- 11) The  $\overline{UV}$  and  $\overline{CC}$  pins are driven low with respect to the SNS pin. Current flow into  $\overline{UV}$  or  $\overline{CC}$  is returned to SNS and therefore is not included in the current measurement.
- 12) Current full-scale rating limits input saturation and nonlinear conversion under high average current signal levels of either polarity. Transient currents up to 1.5 times the current full-scale rating are measured to specified accuracy if the RC filter formed by the internal resistors and external capacitor at the IS1 and IS2 pins limits the average signal level to the Current Full-Scale rating.
- 13) This value deviates proportionally to gain error.

## Looking for pricing, stock, or lifecycle information?

Click below to explore more details on WIN SOURCE:

 [View DS2770BE+ on WIN SOURCE](#)

 [Maxim Integrated](#) Information

## Optimize Your Supply Chain with WIN SOURCE Solutions

-  Global Sourcing Solution
-  Obsolete Management
-  Cost Control Management
-  Shortage Management
-  Alternative Solution
-  Excess Inventory Management