

---

## Features

- Temperature and Voltage Compensated Frequency
- Warning Indication of Lamp Failure by Means of Frequency Doubling only in Direction Mode
- Voltage Dependence of the Car Indicator Lamps also Compensated for Lamp Failure
- Relay Output with High Current-carrying Capacity and Low Saturation Voltage
- Load-dump Protection
- Minimum Lamp Load for Flasher Operation  $\geq 1$  W
- Low Susceptibility to EMI
- Extremely Low Standby Current of 10  $\mu$ A
- Protection According to ISO/TR 7637/1 Level 4 with External Capacitor (C<sub>2</sub>)

## Description

The U6432B is an advanced automotive flasher IC which provides low standby current. Its basic function is equal to Atmel's flasher IC U6043B but low current consumption and frequency doubling disabling make outstanding differences.



---

## Low-power Flasher IC with 18-m $\Omega$ Shunt

---

**U6432B**



# Block Diagram

Figure 1. Car Flasher Application

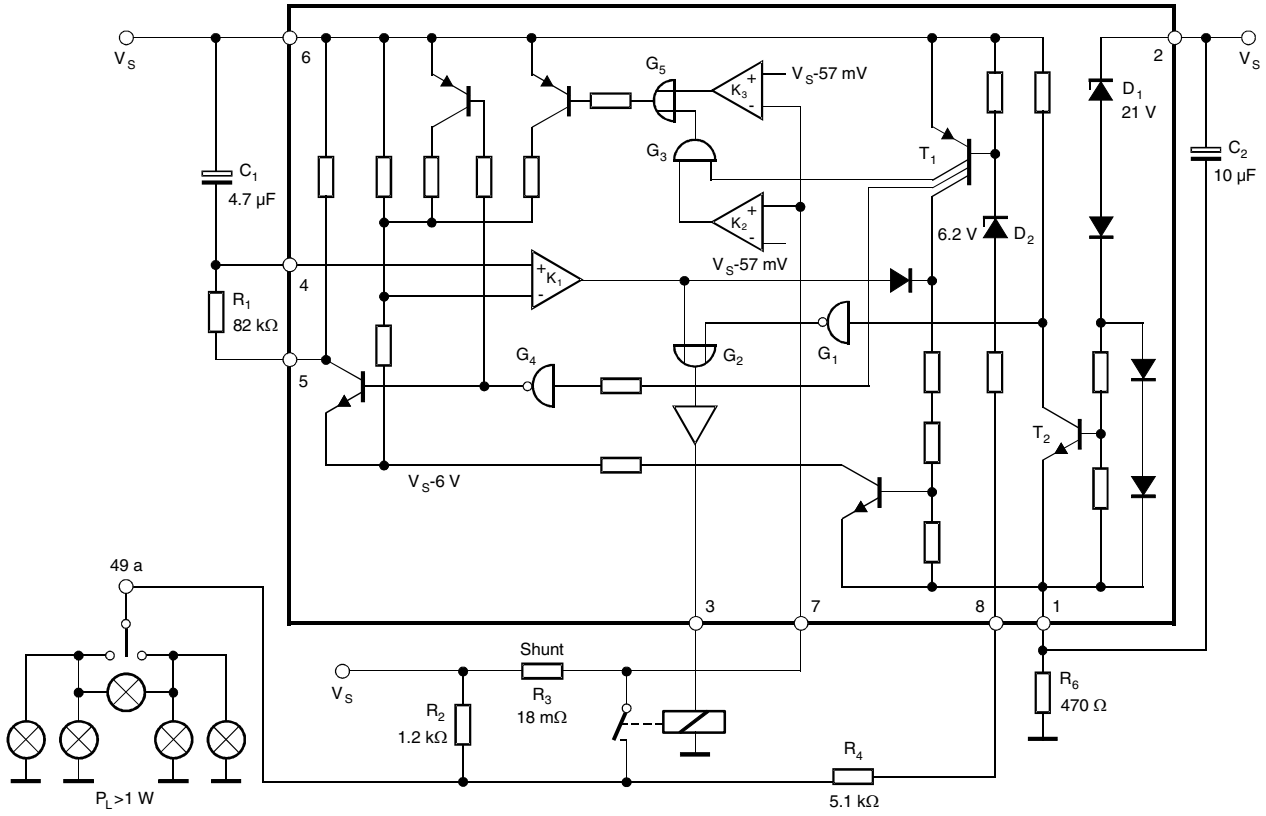

## Pin Configuration

**Figure 2.** Pinning

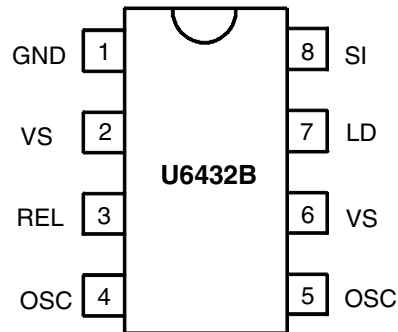

## Pin Description

Pin	Symbol	Function
1	GND	IC ground
2	VS	Supply voltage
3	REL	Relay driver
4	OSC	Oscillator
5	OSC	Oscillator
6	VS	Supply voltage
7	LD	Lamp failure detection
8	SI	Start input (49a)

## Functional Description

### Pin 1, GND

The U6432B is protected against damage in case of battery reversal via resistor  $R_4$  to ground (-31). An integrated protection circuit together with external resistances  $R_2$  and  $R_4$  limits the current pulses in the IC.

### Pin 2, Supply Voltage, $V_S$ power

The arrangement of the supply connections to Pin 2 (and 6) must be so as to ensure that on the connection printed circuit board (PCB), the resistance of  $V_S$  to Pin 6 is lower than that to Pin 2.

### Pin 3, Relay Control Output (Driver)

The relay control output is a high-side driver with a low saturation voltage. It is capable of driving a typical automotive relay with a minimum coil resistance of 60  $\Omega$ .

### Pin 4 and 5, Oscillator

The flashing frequency,  $f_1$ , is determined by the  $R_1C_1$  components as given by the formula below (see Figure 1):

$$f_1 \approx \frac{1}{R_1 \times C_1 \times 1.5} \text{ Hz}$$

where  $C_1 \leq 47 \mu\text{F}$ ,  $R_1 = 6.8 \text{ k}\Omega$  to 510  $\text{k}\Omega$

In case of a lamp outage (see Pin 7) the oscillator frequency is switched to the lamp outage frequency  $f_2$  with  $f_2 \approx 2.2 \times f_1$ .

Duty cycle in normal flashing mode: 50%

Duty cycle in lamp outage mode: 40% (bright phase)

### Pin 6, Supply Voltage, Sense

For accurate monitoring via the shunt resistor, a minimized layer resistance from point  $V_S$ /shunt to Pin 6 is recommended.

### Pin 7

#### Control Signal Threshold (49 mV Comparator)

The detection point for lamp failure can be calculated from the control signal threshold, typically 49 mV with  $V_S = 12 \text{ V}$ . With a measuring resistance of  $R_3 = 18 \text{ m}\Omega$ , the frequency change-over is reached at a lamp load of 21 W + 11.4 W. The variation of the control signal threshold supply voltage takes into account the PTC characteristic of filament lamps.

#### Control Signal Threshold 2 (15-mV Comparator)

A voltage drop at the shunt resistor  $R_3$  between 49 mV and 15 mV lets the flasher work in frequency doubling mode.

If the voltage drop decreases to a value below  $V_{R3\text{MAX}} = 15 \text{ mV}$ , frequency doubling is disabled.

This can be achieved either with a switch which by-passes the shunt resistor (e.g., a special hazard warning switch) or with a small lamp load.

Flasher operation starts with a lamp load of  $P_L \geq 1 \text{ W}$ .

## Pin 8, Start Input

Start condition for flashing:

- Voltage at Pin 8 (see Figure 1)
- $V_8 \leq V_S - (V_{BE(T1)} + V_{Z(D2)})$

Condition for standby:

The resistor  $R_2$  between  $V_S$  and Pin 8 provides an extremely low standby current ( $I_S \leq 10 \mu A$ ). The leakage current depends on the pull-up resistor  $R_2$  according to the following formula:

$$I_{Leak} \approx (V_{BE(T1)} + V_{Z(D2)})/R_2$$

## Application Hint

In order to achieve a high-level immunity against "electrical interference by conduction and coupling" according to ISO/TR 7637/1 test level 4, an electrolytic capacitor  $C_2 = 10 \mu F$  (25 V) between Pin 1 and 2 – mounted close to the IC – is highly recommended.

## Absolute Maximum Ratings

Reference point Pin 1

Parameters		Symbol	Value	Unit
Supply voltage	Pin 2 and 6	$V_S$	18	V
<b>Surge Forward Current</b>				
$t_P = 0.1 \text{ ms}$	Pin 2 and 6	$I_{FSM}$	1.5	A
$t_P = 300 \text{ ms}$	Pin 2 and 6	$I_{FSM}$	1.0	A
$t_P = 300 \text{ ms}$	Pin 8	$I_{FSM}$	30	mA
Output current	Pin 3	$I_O$	0.3	A
<b>Power Dissipation</b>				
$T_{amb} = 95^\circ C$	DIP 8	$P_{tot}$	420	mW
	SO8	$P_{tot}$	340	mW
$T_{amb} = 60^\circ C$	DIP 8	$P_{tot}$	690	mW
	SO8	$P_{tot}$	560	mW
Junction temperature		$T_J$	150	$^\circ C$
Ambient temperature range		$T_{amb}$	-40 to +105	$^\circ C$
Storage temperature range		$T_{stg}$	-55 to +150	$^\circ C$

## Electrical Characteristics

$T_{amb} = 25^{\circ}\text{C}$ ; typical values under normal operation in application circuit Figure 1,  $V_S = 12\text{ V}$  (Pins 2 and 6); reference point ground (-31), unless otherwise specified.

Parameters	Test Conditions	Symbol	Min.	Typ.	Max.	Unit
Supply voltage range	Pin 2 and 6	$V_S$	9		16.5	V
Supply current, dark phase	Pins 2 and 6	$I_S$		4.5	8	mA
Supply current, stand-by	Pins 2 and 6	$I_S$			10	mA
Supply current, bright phase	Pins 2 and 6	$I_S$		7.0	11	mA
Relay output, saturation voltage	$I_O = 150\text{ mA}$ $V_S = 9\text{ V}$ , Pin 3	$V_O$			1.0	V
Relay output reverse current	Pin 3	$I_O$			0.1	mA
Relay coil resistance		$R_L$	60			$\Omega$
Start delay	First bright phase	$t_{on}$			10	ms
Frequency determining resistor		$R_1$	6.8		510	k $\Omega$
Frequency determining capacitor		$C_1$			47	$\mu\text{F}$
Frequency tolerance	Normal flashing, basic frequency $f_1$ not including the tolerances of the external components $R_1$ and $C_1$	$\Delta f_1$	-5		+5	%
Bright period	Basic frequency $f_1$ $V_S = 9\text{ to }15\text{ V}$	$\Delta f_1$	47		53	%
Bright period	Control frequency $f_2$ $V_S = 9\text{ to }15\text{ V}$	$\Delta f_2$	37		45	%
Frequency increase	Lamp failure, $V_S = 9\text{ to }15\text{ V}$	$f_2$	$2.15 \times f_1$		$2.3 \times f_1$	Hz
Control signal threshold 1	$V_S = 15\text{ V}$ $V_S = 9\text{ V}$ $V_S = 12\text{ V}$ , Pin 7	$V_{R3}$	50 43 47	53 45 49	57 47 51	mV
Control signal threshold 2		$V_{R3}$			15	mV
Lamp load		$P_L$	1			W

**Ordering Information**

Extended Type Number	Package	Remarks
U6432B	DIP8	-
U6432B-FP	SO8	-

**Package Information**

**DIP8**

Package: DIP 8  
Dimensions in mm

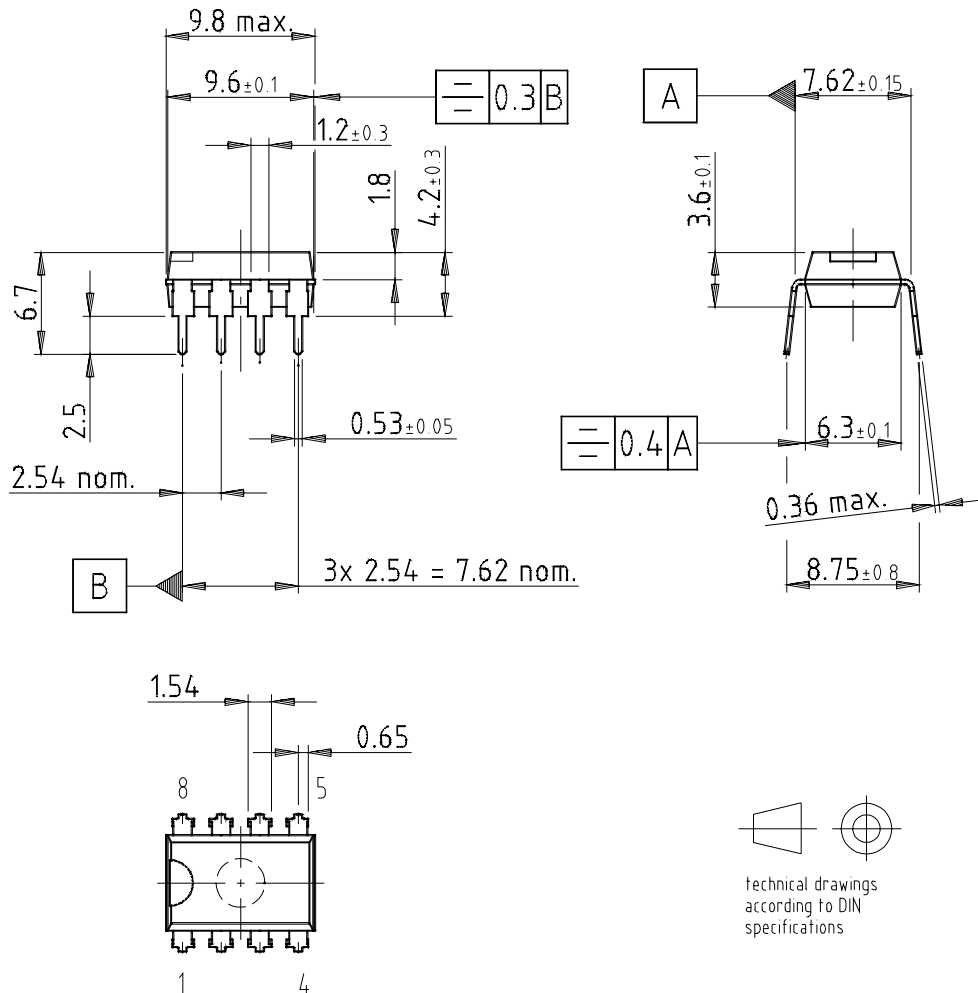

Drawing-No: 6.543-5040.01-4  
Issue: 1, 16.01.02

S08

Package S08  
Dimensions in mm

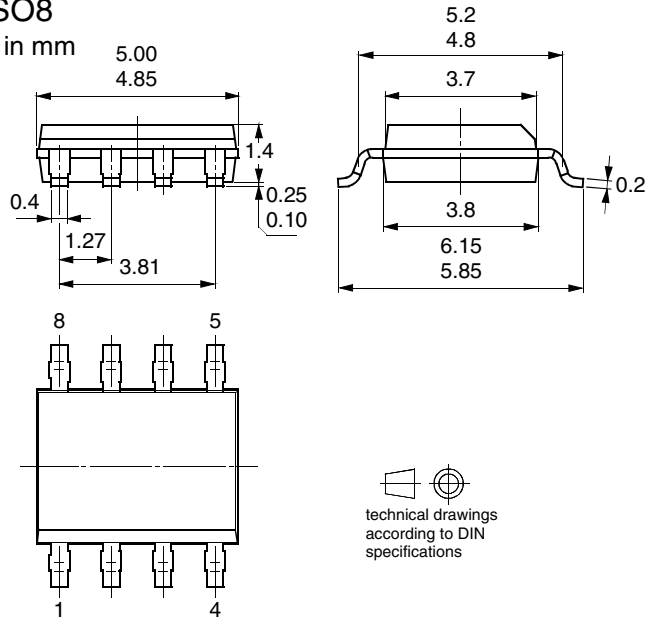



## Atmel Corporation

2325 Orchard Parkway  
San Jose, CA 95131  
Tel: 1(408) 441-0311  
Fax: 1(408) 487-2600

## Regional Headquarters

### Europe

Atmel Sarl  
Route des Arsenaux 41  
Case Postale 80  
CH-1705 Fribourg  
Switzerland  
Tel: (41) 26-426-5555  
Fax: (41) 26-426-5500

### Asia

Room 1219  
Chinachem Golden Plaza  
77 Mody Road Tsimshatsui  
East Kowloon  
Hong Kong  
Tel: (852) 2721-9778  
Fax: (852) 2722-1369

### Japan

9F, Tonetsu Shinkawa Bldg.  
1-24-8 Shinkawa  
Chuo-ku, Tokyo 104-0033  
Japan  
Tel: (81) 3-3523-3551  
Fax: (81) 3-3523-7581

## Atmel Operations

### Memory

2325 Orchard Parkway  
San Jose, CA 95131  
Tel: 1(408) 441-0311  
Fax: 1(408) 436-4314

### Microcontrollers

2325 Orchard Parkway  
San Jose, CA 95131  
Tel: 1(408) 441-0311  
Fax: 1(408) 436-4314

La Chantrerie  
BP 70602  
44306 Nantes Cedex 3, France  
Tel: (33) 2-40-18-18-18  
Fax: (33) 2-40-18-19-60

### ASIC/ASSP/Smart Cards

Zone Industrielle  
13106 Rousset Cedex, France  
Tel: (33) 4-42-53-60-00  
Fax: (33) 4-42-53-60-01

1150 East Cheyenne Mtn. Blvd.  
Colorado Springs, CO 80906  
Tel: 1(719) 576-3300  
Fax: 1(719) 540-1759

Scottish Enterprise Technology Park  
Maxwell Building  
East Kilbride G75 0QR, Scotland  
Tel: (44) 1355-803-000  
Fax: (44) 1355-242-743

### RF/Automotive

Theresienstrasse 2  
Postfach 3535  
74025 Heilbronn, Germany  
Tel: (49) 71-31-67-0  
Fax: (49) 71-31-67-2340

1150 East Cheyenne Mtn. Blvd.  
Colorado Springs, CO 80906  
Tel: 1(719) 576-3300  
Fax: 1(719) 540-1759

### Biometrics/Imaging/Hi-Rel MPU/ High Speed Converters/RF Datacom

Avenue de Rochepleine  
BP 123  
38521 Saint-Egreve Cedex, France  
Tel: (33) 4-76-58-30-00  
Fax: (33) 4-76-58-34-80

---

### e-mail

[literature@atmel.com](mailto:literature@atmel.com)

### Web Site

<http://www.atmel.com>

**Disclaimer:** Atmel Corporation makes no warranty for the use of its products, other than those expressly contained in the Company's standard warranty which is detailed in Atmel's Terms and Conditions located on the Company's web site. The Company assumes no responsibility for any errors which may appear in this document, reserves the right to change devices or specifications detailed herein at any time without notice, and does not make any commitment to update the information contained herein. No licenses to patents or other intellectual property of Atmel are granted by the Company in connection with the sale of Atmel products, expressly or by implication. Atmel's products are not authorized for use as critical components in life support devices or systems.

© Atmel Corporation 2003. All rights reserved.

Atmel® and combinations thereof are the registered trademarks of Atmel Corporation or its subsidiaries.

Other terms and product names may be the trademarks of others.



Printed on recycled paper.

## Looking for pricing, stock, or lifecycle information?

Click below to explore more details on WIN SOURCE:

- [View U6432B-MFPG3 on WIN SOURCE](#)
- [Microchip Technology Information](#)

## Optimize Your Supply Chain with WIN SOURCE Solutions

- ✓ Global Sourcing Solution
- ✓ Obsolete Management
- ✓ Cost Control Management
- ✓ Shortage Management
- ✓ Alternative Solution
- ✓ Excess Inventory Management