

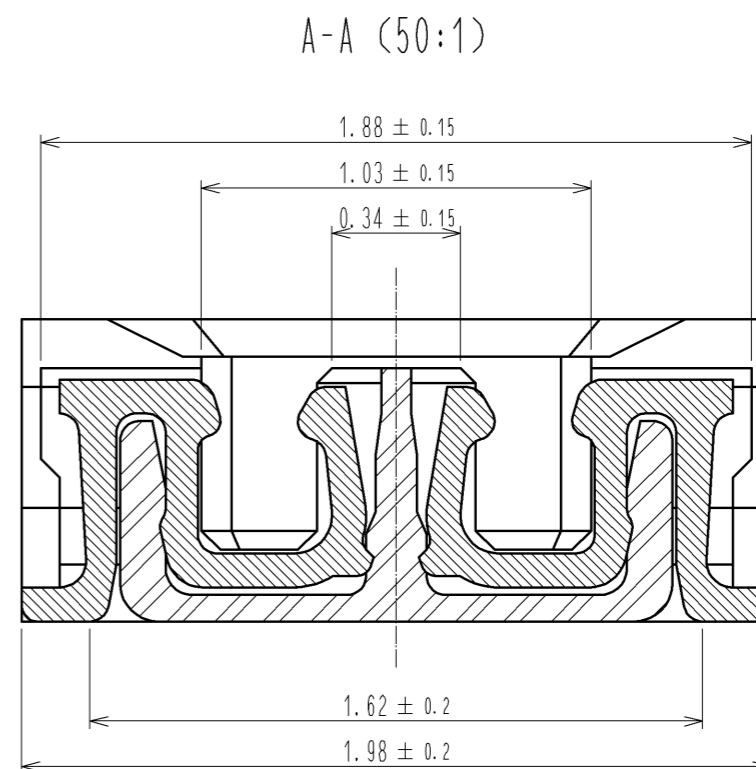

**THE DATASHEET OF
BM14B(0.8)-40DS-0.4V(52)**

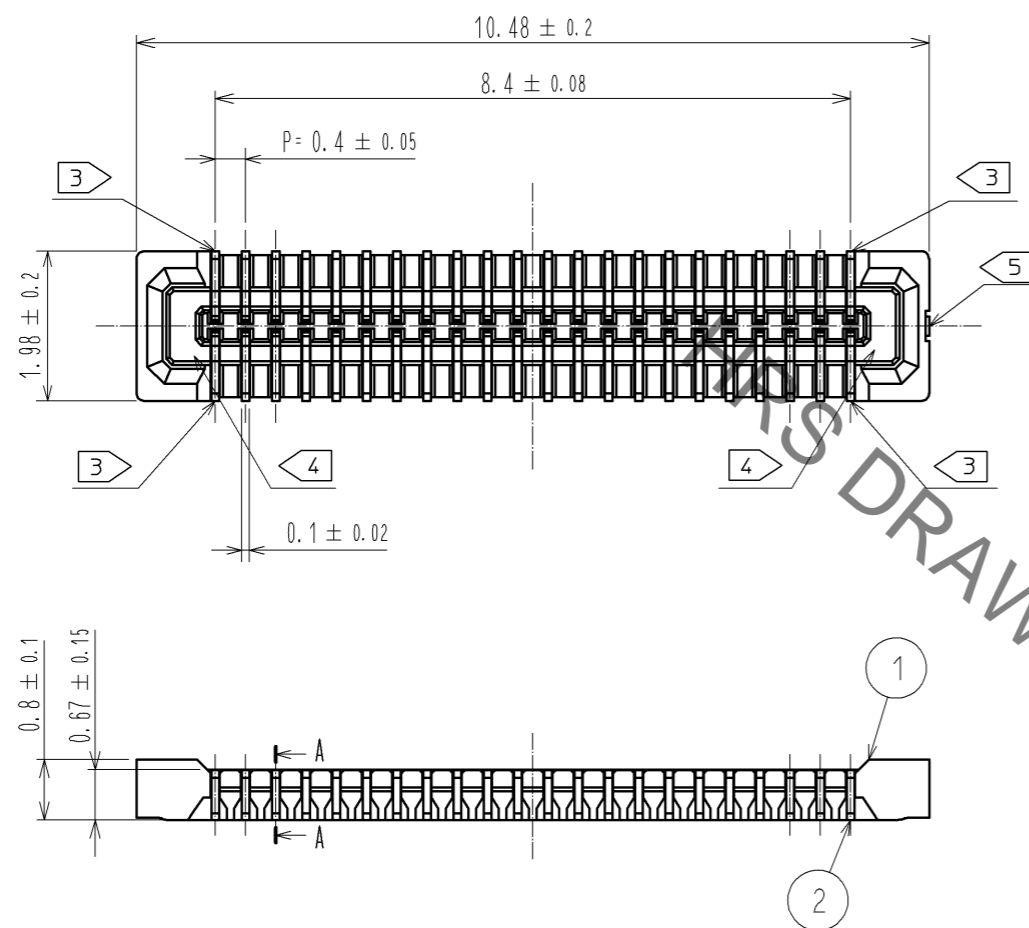

Sep.1.2019 Copyright 2019 HIROSE ELECTRIC CO., LTD. All Rights Reserved.
In case of consideration for using Automotive equipment / device which demand high reliability, kindly contact our sales window correspondents.



ENGAGEMENT FIGURE (50:1)

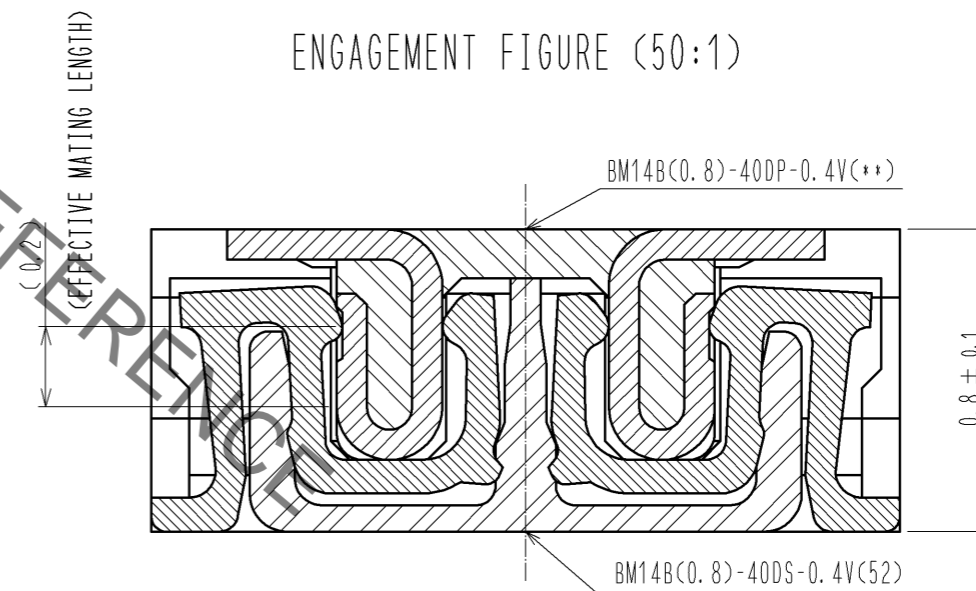

- NOTE) 1. ALL LEAD CO-PLANARITY SHALL BE 0.08mm MAX
 2. CONTACT PLATING SPECIFICATIONS.
 CONTACT AREA : GOLD 0.05 μm MIN
 SMT LEAD : GOLD 0.05 μm MIN
 UNDERPLATING : NICKEL 1 μm MIN
 (SURFACE : SEALING)
 3. EACH CONTACTS AT 4 CORNERS ARE PROVIDED FOR METAL FITTINGS AND GROUNDING PURPOSE.
 4. HRS MARK AND CAV NO. ARE INDICATED IN APPROX POSITION SHOWN.
 5. GATE POSITION IS INDICATED IN APPROX POSITION SHOWN.

NO.	MATERIAL	FINISH . REMARKS	NO.	MATERIAL	FINISH . REMARKS
3	PS	CLEAR (ENBOSSED CARRIER TAPE)	7	PS	CLEAR (REINFORCEMENT COLLAR)
2	PHOSPHOR BRONZE	2	6	POLYIMIDE	BROWN (HEAT RESISTANCE TAPE)
1	LCP	UL94 V-0. BLACK	5	PS	BLACK (PLASTIC REEL)
			4	POLYESTER	CLEAR (COVER TAPE)

UNITS	SCALE	COUNT	DESCRIPTION OF REVISIONS	DESIGNED	CHECKED	DATE
mm	10:1	△	APPROVED : KH. IKEDA 11.04.11			
			CHECKED : AR. TAKAHASHI 11.04.08			
			DESIGNED : SH. HOSODA 11.04.08			
			DRAWN : KR. AJITO 11.04.06			

DRAWING NO.	PART NO.	CODE NO.
EDC3-319843-02	BM14B(0.8)-40DS-0.4V(52)	CL684-8008-9-52

Sep.1.2019 Copyright 2019 HIROSE ELECTRIC CO., LTD. All Rights Reserved.
 In case of consideration for using Automotive equipment / device which demand high reliability, kindly contact our sales window correspondents.

◆ RECOMMENDED PCB LAYOUT

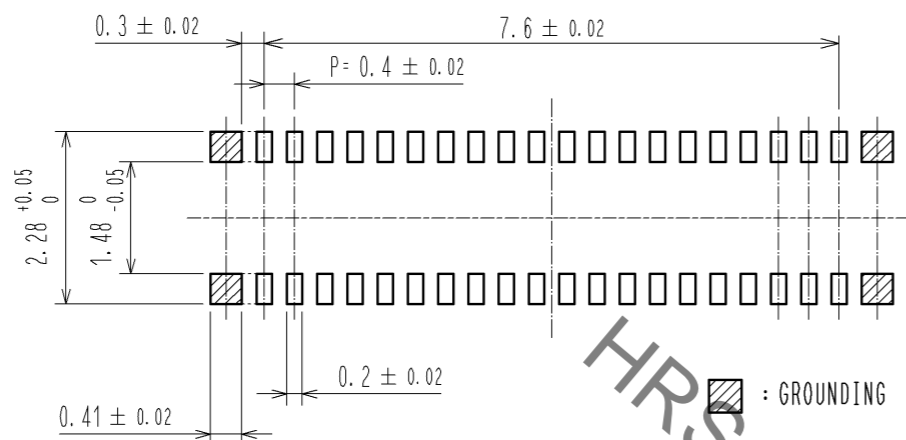

◆ RECOMMENDED METAL MASK DIMENSIONS

METAL MASK THICKNESS : 100 μm

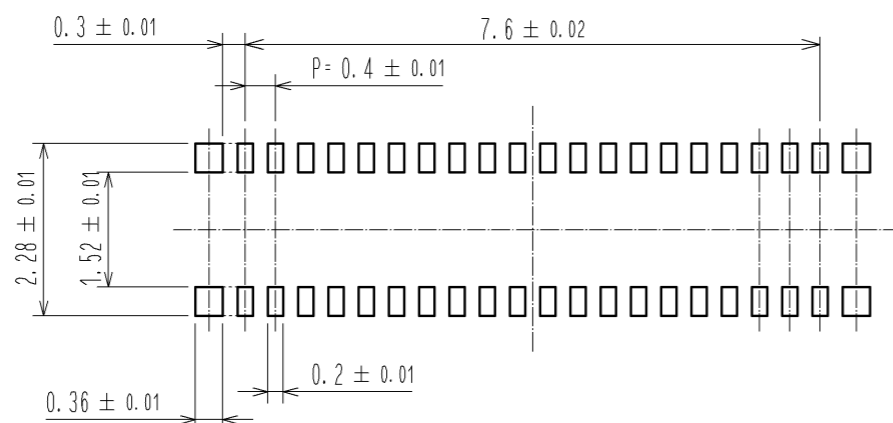

⑥ RECOMMENDED REFLOW TEMPERATURE PROFILE USING LEAD-FREE SOLDER PASTE.

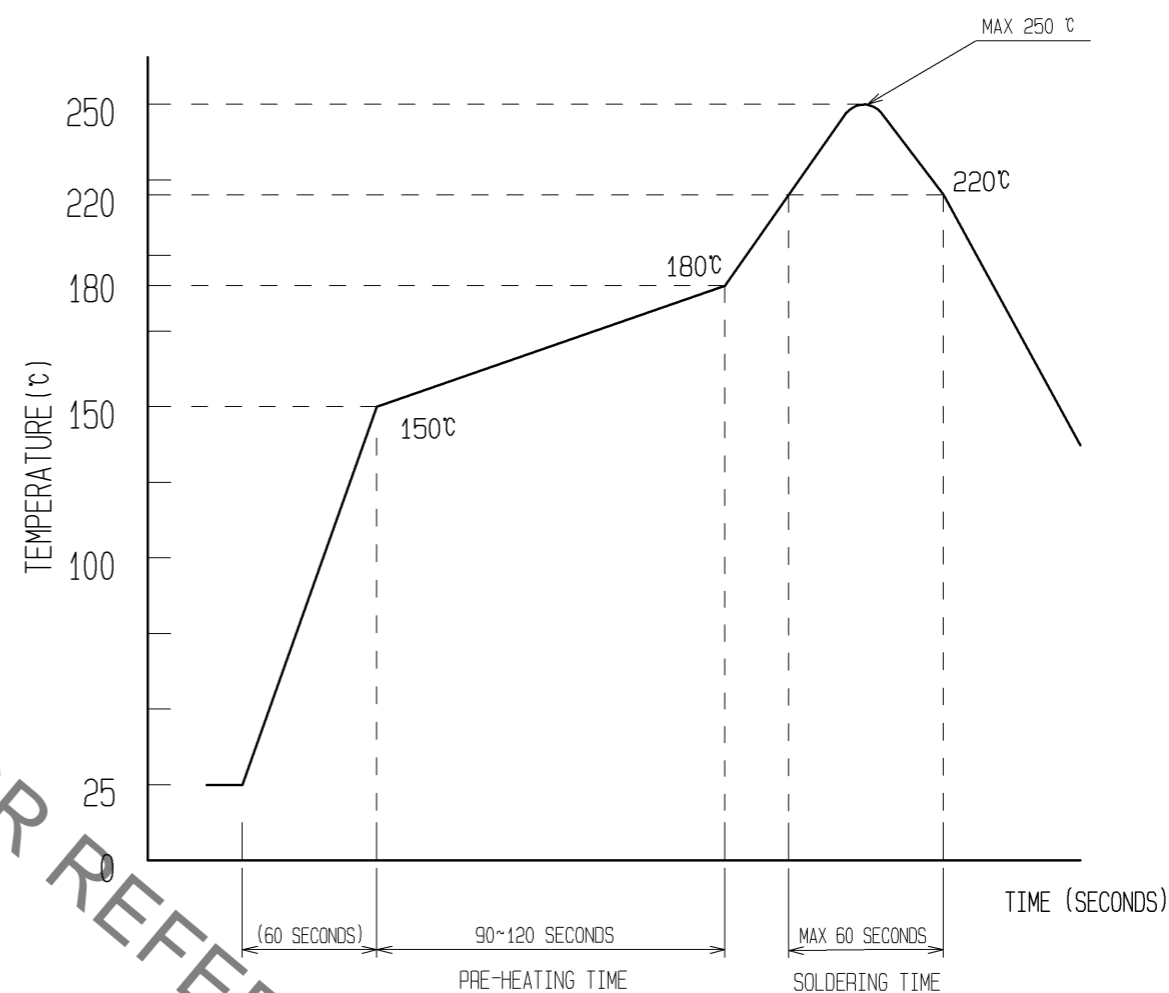

REFLOW METHOD: IR REFLOW
 NUMBER OF REFLOW CYCLES: 2 CYCLES MAX.

- 1) REFLOW TIME
 DURATION ABOVE 220°C, 60 SEC. MAX.
 (PEAK TEMPERATURE: 250°C MAX)
- 2) PRE-HEAT TIME
 PRE-HEAT TEMPERATURE(MIN): 150°C
 PRE-HEAT TEMPERATURE(MAX): 180°C
 PRE-HEAT TIME: 90-120 sec.

⑥ THIS TEMPERATURE PROFILE IS PER THE CONDITIONS SHOWN ABOVE.
 ADDITIONAL FACTORS, SUCH AS SOLDER PASTE TYPE, PCB SIZE AND
 OTHER MOUNTED COMPONENTS COULD AFFECT THE PROFILE, THEREFORE,
 A THOROUGH EVALUATION OF MOUNTING CONDITION IS REQUIRED
 PRIOR TO PRODUCTION. TEMPERATURE IS MEASURED AT CONTACT LEAD.

HRS	DRAWING NO.	EDC3-319843-02
	PART NO.	BM14B(0.8)-40DS-0.4V(52)
	CODE NO.	CL684-8008-9-52

△ 2/3

Sep.1.2019 Copyright 2019 HIROSE ELECTRIC CO., LTD. All Rights Reserved.
In case of consideration for using Automotive equipment / device which demand high reliability, kindly contact our sales window correspondents.

EMBOSED CARRIER TAPE PACKAGING (5:1)

STYLE AND DIMENTION OF REEL (FREE)

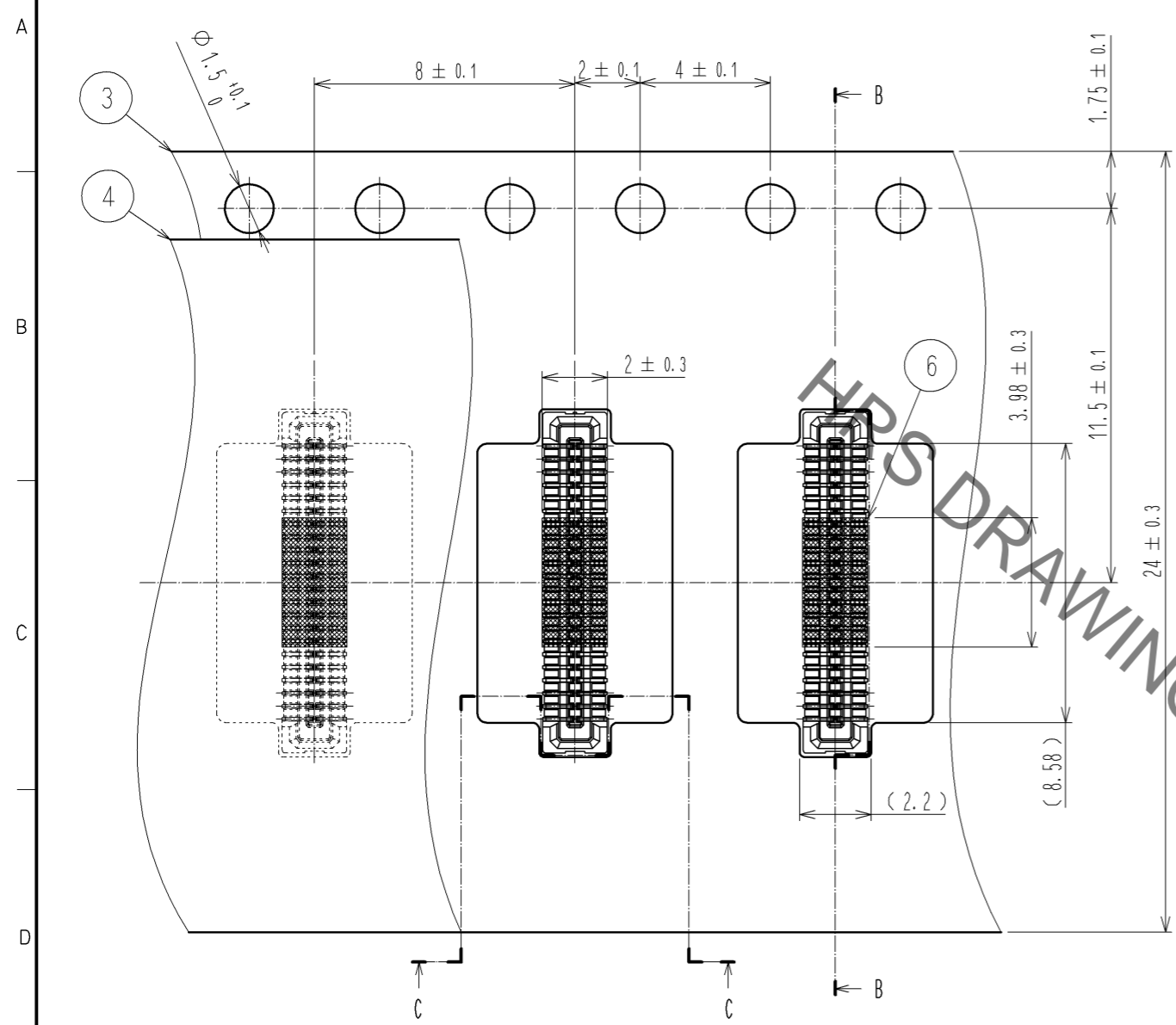

B-B (5:1)

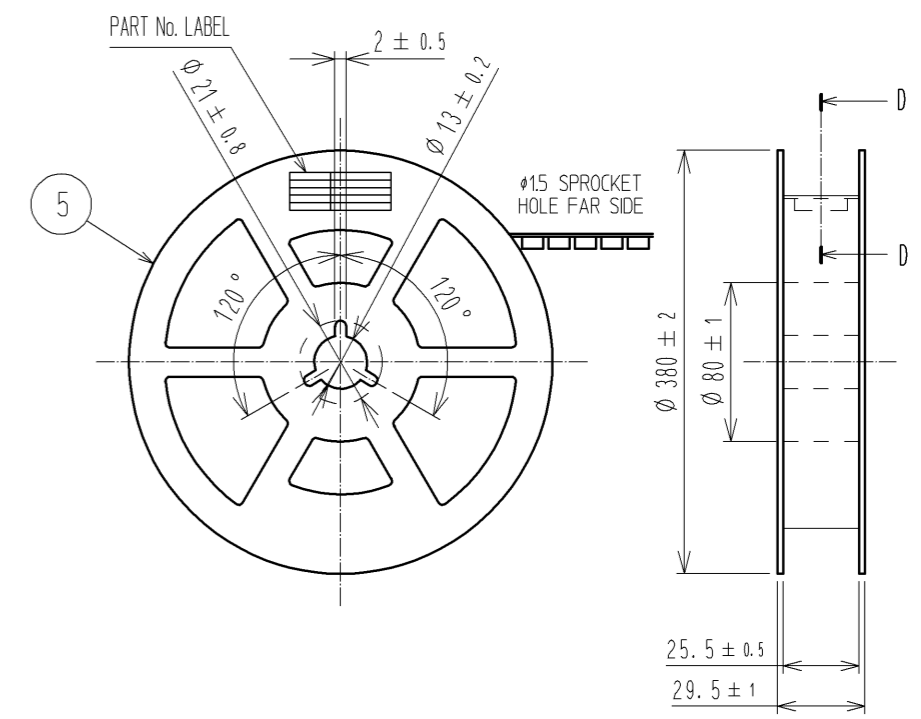

DETAIL OF PART No. LABEL

製造年月日	** ** *	DATE OF MANUFACTURED
製品コード	CL0684-8008-9-(52)	CODE No.
製品名	BM14B(0.8)-40DS-0.4V(52)	PART No.
数量	8,000	QUANTITY
納入者	ヒロセ電機(株)	SUPPLIER

E(10:1)

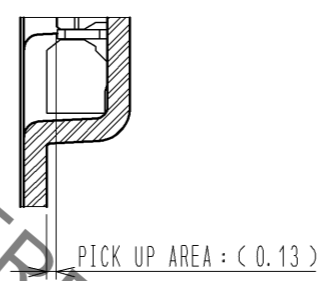

C-C (5:1)

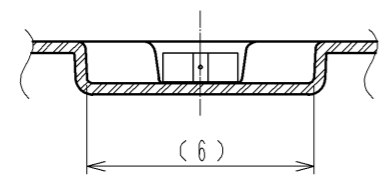

DIRECTION OF UNREELING

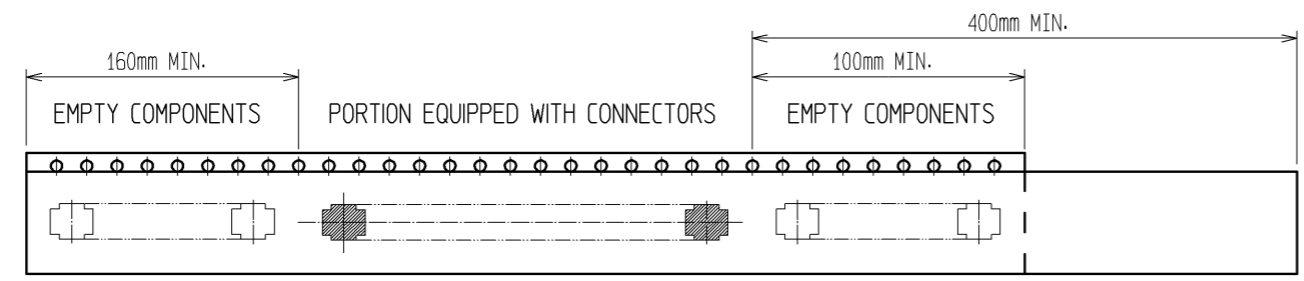
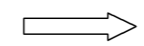

TRAILER

9 TAPING (FREE)

LEADER

D-D (FREE)

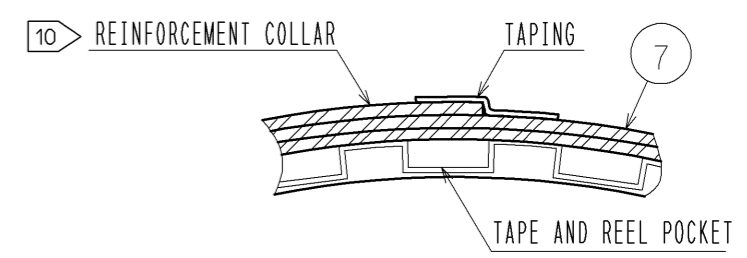

- 7. PER REEL 8000 CONNECTORS.
- 8. THE DIMENSIONS IN PARENTHESES ARE FOR REFERENCE.
- 9 REFER TO JIS C 0806(PACKAGING OF COMPONENTS FOR AUTOMATIC HANDLING)
- 10 AFTER PACKAGING, ROLL 2 METERS OF THE REINFORCEMENT COLLAR TO OUTER CIRCUMFERENCE OF TAPE AND REEL POCKET, AND TAPE DOWN AT THE END THE COLLAR.

HRS	DRAWING NO.	EDC3-319843-02
	PART NO.	BM14B(0.8)-40DS-0.4V(52)
	CODE NO.	CL684-8008-9-52
		$\triangle 3/3$

Looking for pricing, stock, or lifecycle information?

Click below to explore more details on WIN SOURCE:

- ⊖ [View BM14B\(0.8\)-40DS-0.4V\(52\) on WIN SOURCE](#)
- ⊖ [Hirose Electric Co Ltd Information](#)

Optimize Your Supply Chain with WIN SOURCE Solutions

- ✓ Global Sourcing Solution
- ✓ Obsolete Management
- ✓ Cost Control Management
- ✓ Shortage Management
- ✓ Alternative Solution
- ✓ Excess Inventory Management