



**THE DATASHEET OF  
MAX5932ESA+T**



**EVALUATION KIT  
AVAILABLE**



# Positive High-Voltage, Hot-Swap Controller

**MAX5932**

## General Description

The MAX5932 is a fully integrated hot-swap controller for +9V to +80V positive supply rails. The MAX5932 allows for the safe insertion and removal of circuit cards into a live backplane without causing glitches on the backplane power-supply rail. This device is pin and function compatible to LT1641-1. The MAX5932 features a programmable foldback-current limit. If the device remains in current limit for more than a programmable time, the external n-channel MOSFET latches off. Other features include a programmable undervoltage lockout and a programmable output-voltage slew rate through an external n-channel MOSFET.

The MAX5932 provides a power-good output (PWRGD) to indicate the status of the output voltage. For a variety of PWRGD/PWRGD, latch/autoretry-fault management, autoretry duty-cycle options, refer to the MAX5933 and MAX5934 data sheets.

The MAX5932 operates in the -40°C to +85°C extended temperature range. This device is available in an 8-pin SO package.

## Applications

Hot Board Insertion  
Electronic Circuit Breaker  
Industrial High-Side Switch/Circuit Breaker  
Network Routers and Switches  
24V/48V Industrial/Alarm Systems

*Typical Application Circuit appears at end of data sheet.*

## Features

- ◆ Pin and Function Compatible with LT1641-1
- ◆ Provides Safe Hot Swap for +9V to +80V Power Supplies
- ◆ Safe Board Insertion and Removal from Live Backplanes
- ◆ Active-High Power-Good Output (PWRGD)
- ◆ Programmable Foldback-Current Limiting
- ◆ High-Side Drive for an External N-Channel MOSFET
- ◆ Undervoltage Lockout (UVLO)
- ◆ Overvoltage Protection
- ◆ Latched Fault Management
- ◆ User-Programmable Supply Voltage Power-Up Rate

## Ordering Information

PART	TEMP RANGE	PIN-PACKAGE
MAX5932ESA	-40°C to +85°C	8 SO

## Pin Configuration

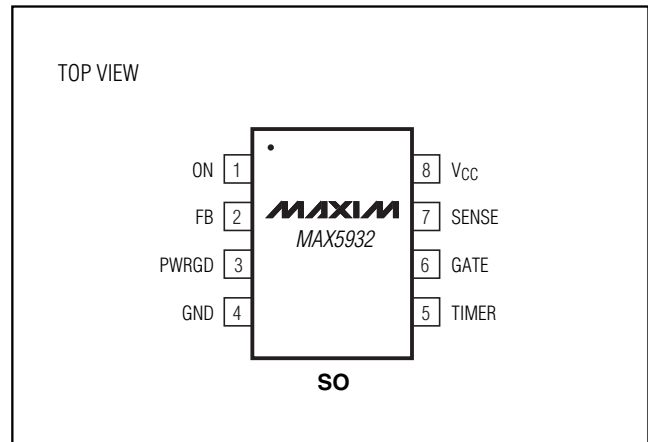

# Positive High-Voltage, Hot-Swap Controller

## ABSOLUTE MAXIMUM RATINGS

(Voltages referenced to GND)

V <sub>CC</sub> .....	-0.3V to +85V
SENSE, FB, ON .....	-0.3V to (V <sub>CC</sub> + 0.3V)
TIMER, PWRGD .....	-0.3V to +85V
GATE .....	-0.3V to +95V
Maximum GATE Current .....	-50mA, +150mA
Maximum Current into Any Other Pin.....	±50mA

Continuous Power Dissipation (T<sub>A</sub> = +70°C)

8-Pin SO (derate 5.9mW/°C above +70°C).....	470mW
Operating Temperature Range .....	-40°C to +85°C
Maximum Junction Temperature .....	+150°C
Storage Temperature Range .....	-60°C to +150°C
ESD Rating (Human Body Model).....	2000V
Lead Temperature (soldering, 10s).....	+300°C

Stresses beyond those listed under "Absolute Maximum Ratings" may cause permanent damage to the device. These are stress ratings only, and functional operation of the device at these or any other conditions beyond those indicated in the operational sections of the specifications is not implied. Exposure to absolute maximum rating conditions for extended periods may affect device reliability.

## ELECTRICAL CHARACTERISTICS

(V<sub>CC</sub> = +24V, GND = 0V, T<sub>A</sub> = -40°C to +85°C, unless otherwise noted. Typical values are at T<sub>A</sub> = +25°C.) (Note 1)

PARAMETER	SYMBOL	CONDITIONS	MIN	TYP	MAX	UNITS	
Supply Voltage Range	V <sub>CC</sub>		9		80	V	
Supply Current	I <sub>CC</sub>	V <sub>ON</sub> = 3V, V <sub>CC</sub> = 80V		1.4	3.5	mA	
V <sub>CC</sub> Undervoltage Lockout	V <sub>LKO</sub>	V <sub>CC</sub> low-to-high transition	7.5	8.3	8.8	V	
V <sub>CC</sub> Undervoltage Lockout Hysteresis	V <sub>LKOHYST</sub>			0.4		V	
FB High-Voltage Threshold	V <sub>FBH</sub>	FB low-to-high transition	1.280	1.313	1.345	V	
FB Low-Voltage Threshold	V <sub>FBL</sub>	FB high-to-low transition	1.221	1.233	1.245	V	
FB Hysteresis	V <sub>FBHYST</sub>			80		mV	
FB Input Bias Current	I <sub>INFB</sub>	V <sub>FB</sub> = 0V	-1		+1	μA	
FB Threshold Line Regulation	ΔV <sub>FB</sub>	9V ≤ V <sub>CC</sub> ≤ 80V, ON = 0V, T <sub>A</sub> = 0°C to +70°C			0.05	mV/V	
SENSE Trip Voltage (V <sub>CC</sub> - V <sub>SENSE</sub> )	V <sub>SENSETRIP</sub>	V <sub>FB</sub> = 0V, T <sub>A</sub> = 0°C to +70°C	8	12	17	mV	
		V <sub>FB</sub> = 1V, T <sub>A</sub> = 0°C to +70°C	39	47	55		
GATE Pullup Current	I <sub>GATEUP</sub>	Charge pump on, V <sub>GATE</sub> = 7V	-5	-10	-20	μA	
GATE Pulldown Current	I <sub>GATEDN</sub>	Any fault condition, V <sub>GATE</sub> = 2V	35	70	100	mA	
External N-Channel Gate Drive	ΔV <sub>GATE</sub>	V <sub>GATE</sub> - V <sub>CC</sub>	V <sub>CC</sub> = 10.8V to 20V	4.5	6.2	18	V
			V <sub>CC</sub> = 20V to 80V	10	13.6	18	
TIMER Pullup Current	I <sub>TIMERUP</sub>	V <sub>TIMER</sub> = 0V	-24	-80	-120	μA	
TIMER Pulldown Current	I <sub>TIMERON</sub>	V <sub>TIMER</sub> = 1V	1.5	3	4.5	μA	
ON Logic-High Threshold	V <sub>ONH</sub>	ON low-to-high transition	1.280	1.313	1.355	V	
ON Logic-Low Threshold	V <sub>ONL</sub>	ON high-to-low transition	1.221	1.233	1.245	V	
ON Hysteresis	V <sub>ONHYST</sub>			80		mV	
ON Input Bias Current	I <sub>INON</sub>	V <sub>ON</sub> = 0V	-1		+1	μA	
PWRGD Leakage Current	I <sub>OH</sub>	V <sub>PWRGD</sub> = 80V			10	μA	
PWRGD Output Low Voltage	V <sub>OL</sub>	I <sub>O</sub> = 2mA			0.4	V	
		I <sub>O</sub> = 4mA			2.5		
SENSE Input Bias Current	I <sub>SENSE</sub>	V <sub>SENSE</sub> = 0V to V <sub>CC</sub>	-1		+3	μA	
Thermal Shutdown		Temperature rising		150		°C	
Thermal Shutdown Hysteresis				20		°C	

# Positive High-Voltage, Hot-Swap Controller

MAX5932

## ELECTRICAL CHARACTERISTICS (continued)

( $V_{CC} = +24V$ ,  $GND = 0V$ ,  $T_A = -40^{\circ}C$  to  $+85^{\circ}C$ , unless otherwise noted. Typical values are at  $T_A = +25^{\circ}C$ .) (Note 1)

PARAMETER	SYMBOL	CONDITIONS	MIN	TYP	MAX	UNITS
ON Low-to-GATE Low Propagation Delay	t <sub>PHLON</sub>	C <sub>GATE</sub> = 0, Figures 1, 2		6		μs
ON High-to-GATE High Propagation Delay	t <sub>PLHON</sub>	C <sub>GATE</sub> = 0, Figures 1, 2		1.7		μs
FB Low-to-PWRGD Low Propagation Delay	t <sub>PHLFB</sub>	Figures 1, 3		3.2		μs
FB High-to-PWRGD High Propagation Delay	t <sub>PLHFB</sub>	Figures 1, 3		1.5		μs
(V <sub>CC</sub> - V <sub>SENSE</sub> ) High-to-GATE Low Propagation Delay	t <sub>PHLSENSE</sub>	T <sub>A</sub> = +25°C, C <sub>GATE</sub> = 0, Figures 1, 4	0.5		2	μs

**Note 1:** All currents into the device are positive and all currents out of the device are negative. All voltages are referenced to ground, unless noted otherwise.

# Positive High-Voltage, Hot-Swap Controller

## Test Circuit and Timing Diagrams

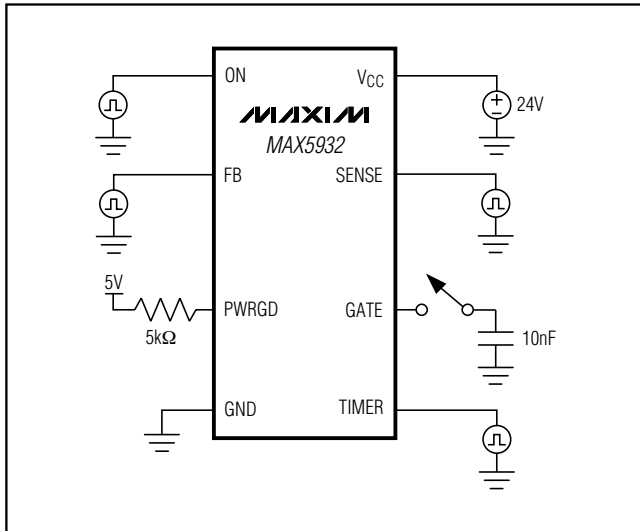

Figure 1. Test Circuit

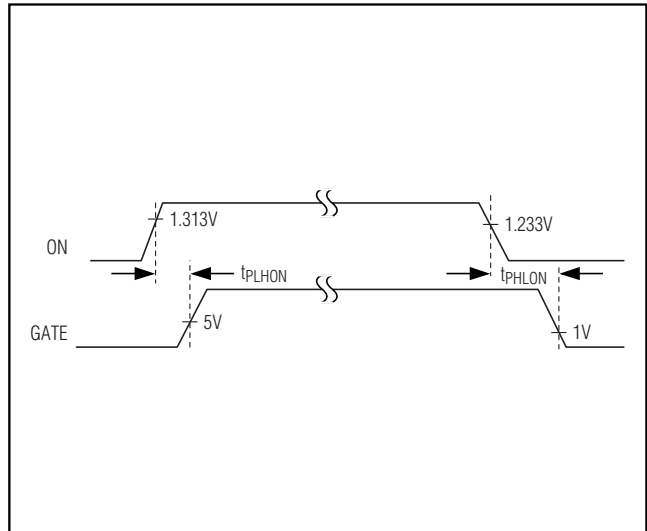

Figure 2. ON to GATE Timing

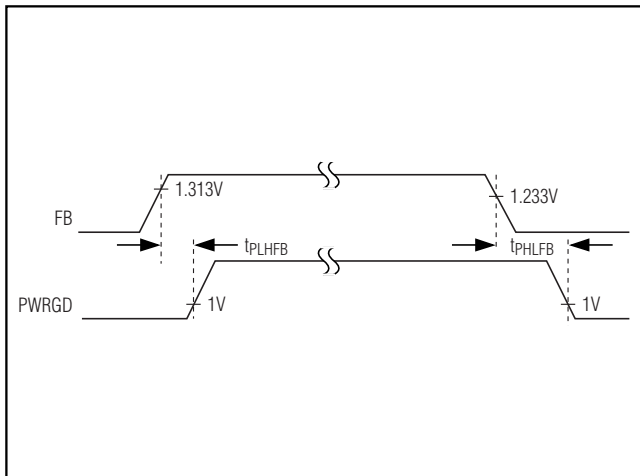

Figure 3. FB to PWRGD Timing

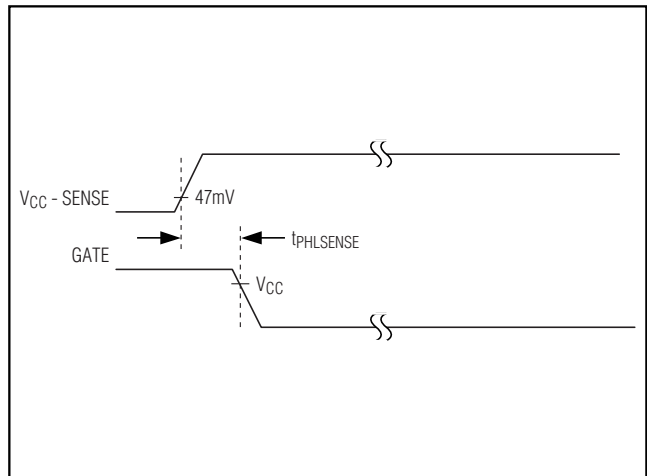

Figure 4. SENSE to GATE Timing

# Positive High-Voltage, Hot-Swap Controller

## Typical Operating Characteristics

( $V_{CC} = +48V$ ,  $T_A = +25^\circ C$ , unless otherwise noted.)

MAX5932

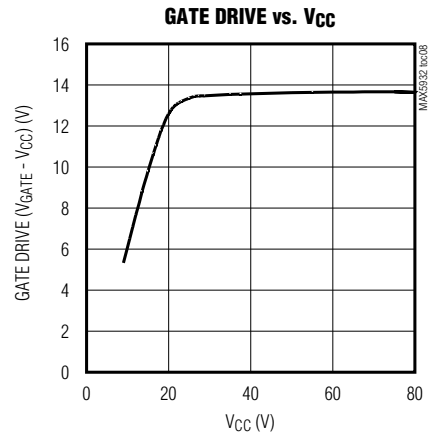
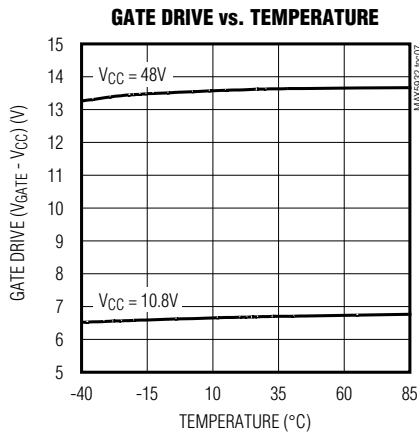
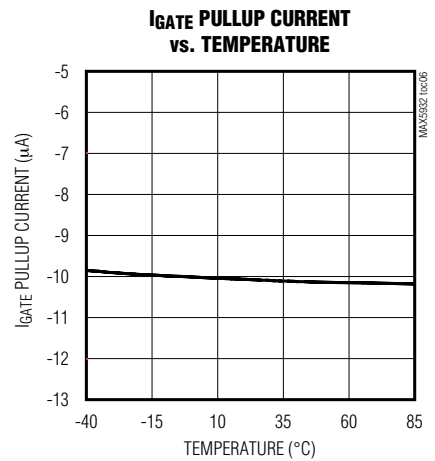
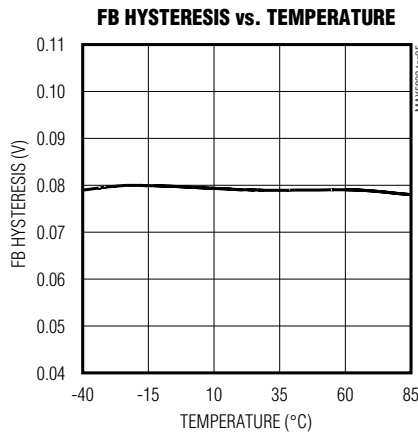
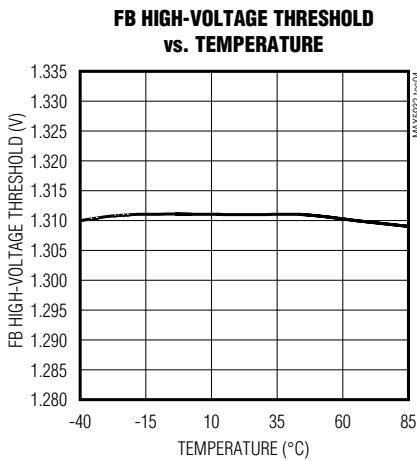
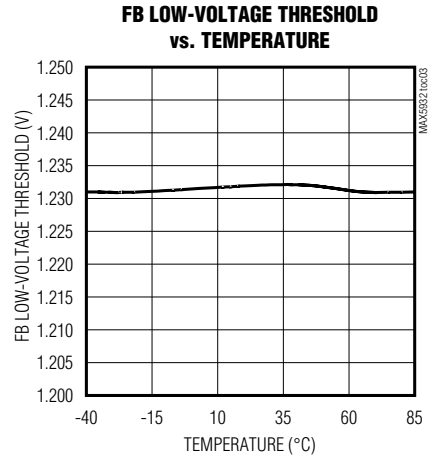
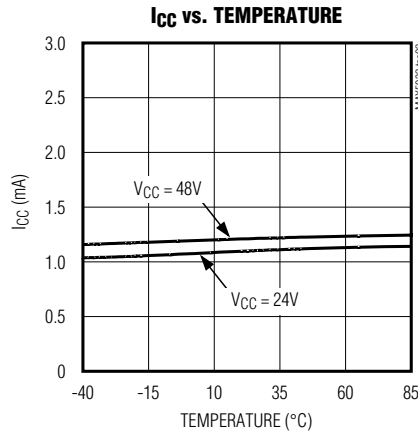
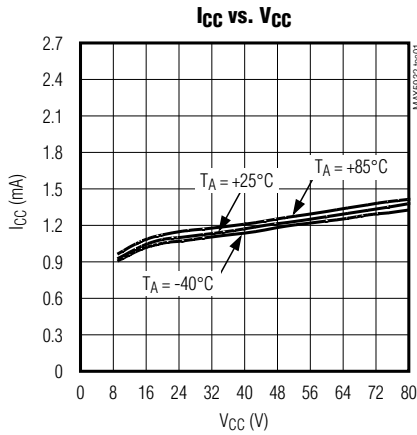

# Positive High-Voltage, Hot-Swap Controller

## Typical Operating Characteristics (continued)

( $V_{CC} = +48V$ ,  $T_A = +25^\circ C$ , unless otherwise noted.)

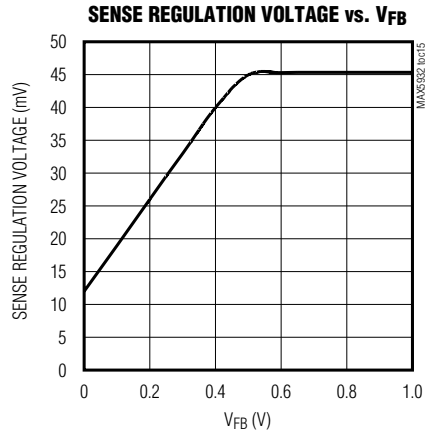
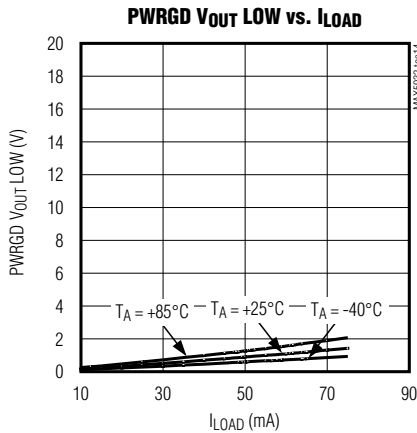
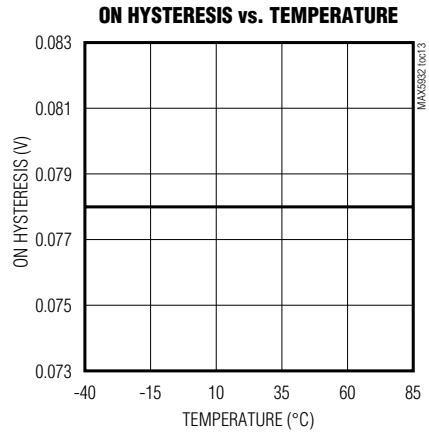
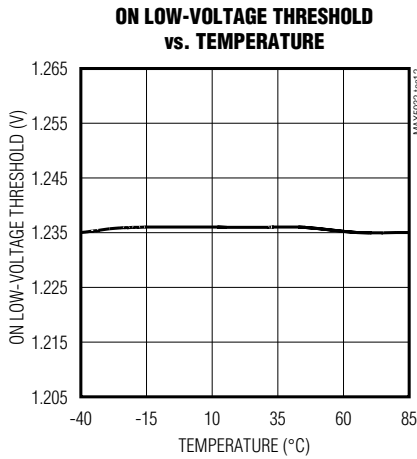
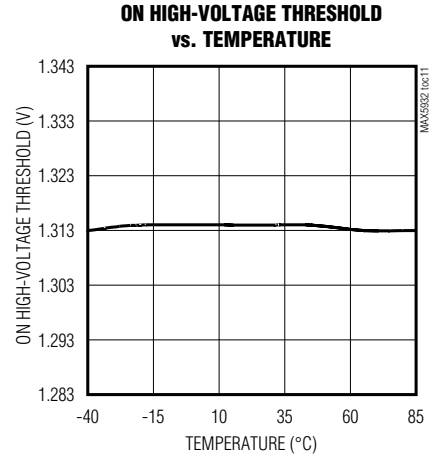
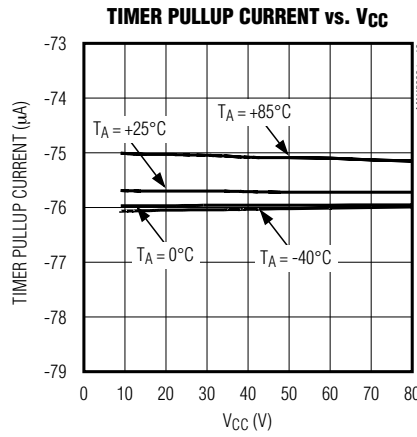
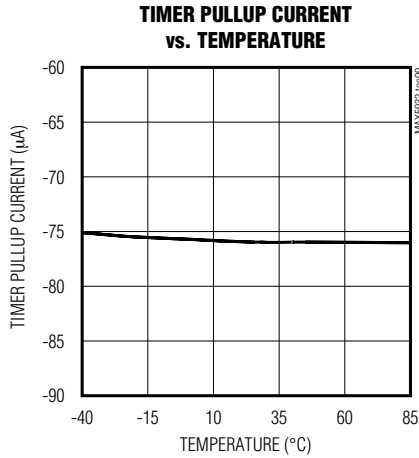

# Positive High-Voltage, Hot-Swap Controller

## Pin Description

MAX5932

PIN	NAME	FUNCTION
1	ON	On/Off Control Input. ON is used to implement the undervoltage lockout threshold and resets the part after a fault condition (see the <i>Detailed Description</i> section).
2	FB	Power-Good Comparator Input. Connect a resistive divider from output to FB to GND to monitor the output voltage (see the <i>Power-Good Detection</i> section). FB is also used as a feedback for the current-limit foldback function.
3	PWRGD	Open-Drain Power-Good Output. PWRGD is high when $V_{FB}$ is higher than $V_{FBH}$ . PWRGD is low when $V_{FB}$ is lower than $V_{FBL}$ .
4	GND	Ground
5	TIMER	Timing Input. Connect a capacitor from TIMER to GND to program the maximum time the part is allowed to remain in current limit (see the <i>TIMER</i> section).
6	GATE	Gate-Drive Output. The high-side gate drive for the external n-channel MOSFET (see the <i>GATE</i> section).
7	SENSE	Current-Sense Input. Connect a sense resistor from $V_{CC}$ to SENSE and the drain of the external n-channel MOSFET.
8	VCC	Power-Supply Input. Bypass $V_{CC}$ to GND with a 0.1 $\mu$ F capacitor. Input voltage range is from +9V to +80V.

# Positive High-Voltage, Hot-Swap Controller

## Functional Diagram

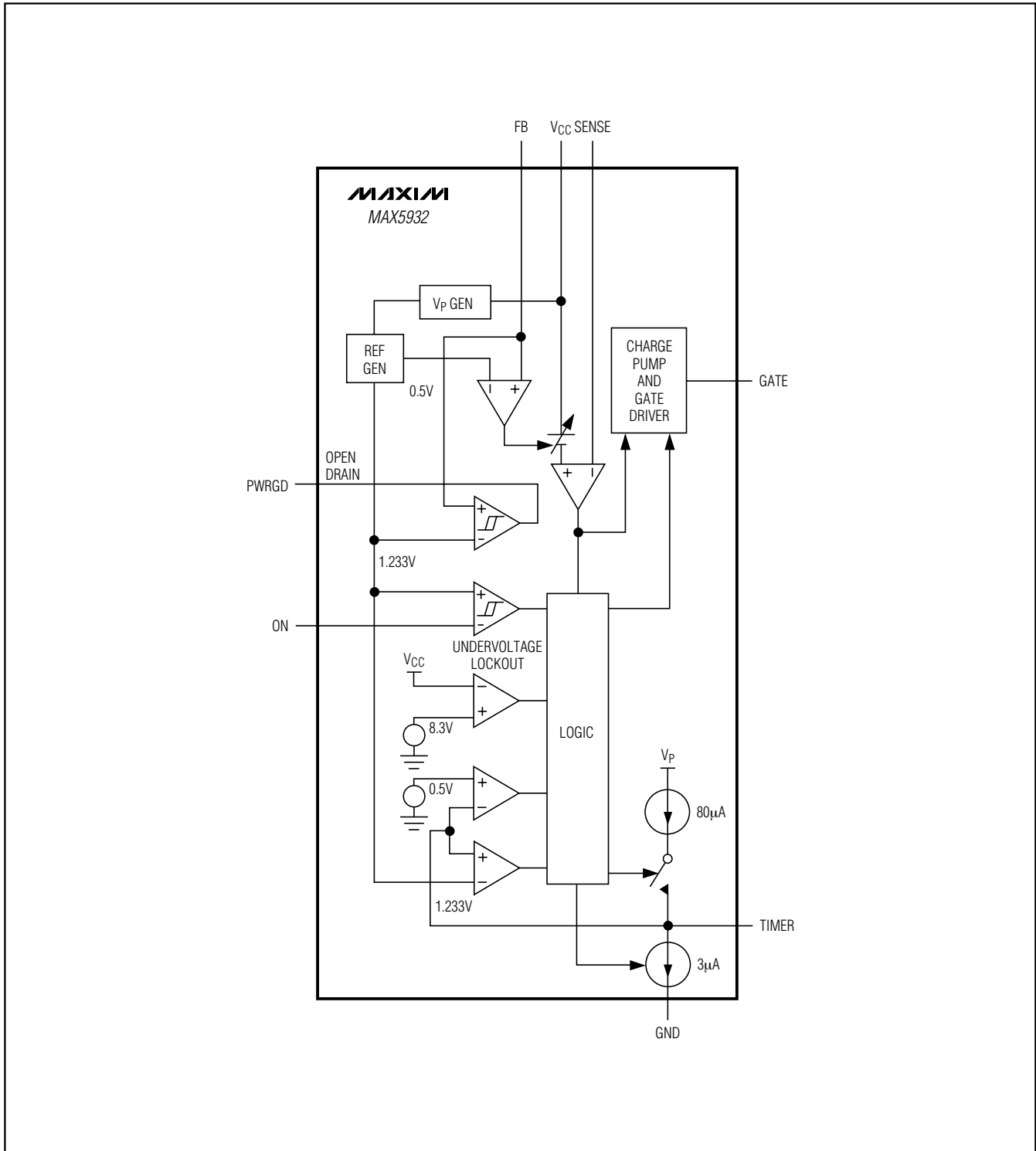

# Positive High-Voltage, Hot-Swap Controller

## Detailed Description

The MAX5932 is a fully integrated hot-swap controller for positive supply rails. The device allows for the safe insertion and removal of circuit cards into live backplanes without causing glitches on the backplane power-supply rail. During startup the MAX5932 acts as a current regulator using an external sense resistor and MOSFET to limit the amount of current drawn by the load.

The MAX5932 features latched-off fault management. When an overcurrent or an overtemperature fault occurs, the MAX5932 turns the external MOSFET off and keeps it off. After the fault condition goes away, cycle the power supply or toggle ON low and high again to unlatch the device.

The MAX5932 operates from +9V to +80V supply voltage range and has a default undervoltage lockout (UVLO) set to +8.3V. The UVLO threshold is adjustable using a resistive divider connected from V<sub>CC</sub> to ON to GND (see R1 and R2 in Figure 5).

The MAX5932 monitors the input voltage, the output voltage, the output current, and the die temperature. This device features a power-good output (PWRGD) to indicate the status of the output voltage by monitoring the voltage at FB (see the *Power-Good Detection* section).

As shown in Figure 5, a sense resistor is connected between V<sub>CC</sub> and SENSE to sense the load current. The device regulates the voltage across the sense resistor ( $V_{IN} - V_{SENSE}$ ) to 47mV when the voltage at FB  $\geq 0.5V$ . The current-limit threshold ( $V_{SENSETRIP}$ ) decreases linearly from 47mV to 12mV as FB decreases from 0.5V to 0V.

An undervoltage fault is detected when ON goes below the threshold,  $V_{ONL} = 1.233V$ , which causes the voltage at GATE to go low, and results in turning off the MOSFET. To turn the MOSFET on again, ON must pass the  $V_{ONH} = 1.313V$  threshold.

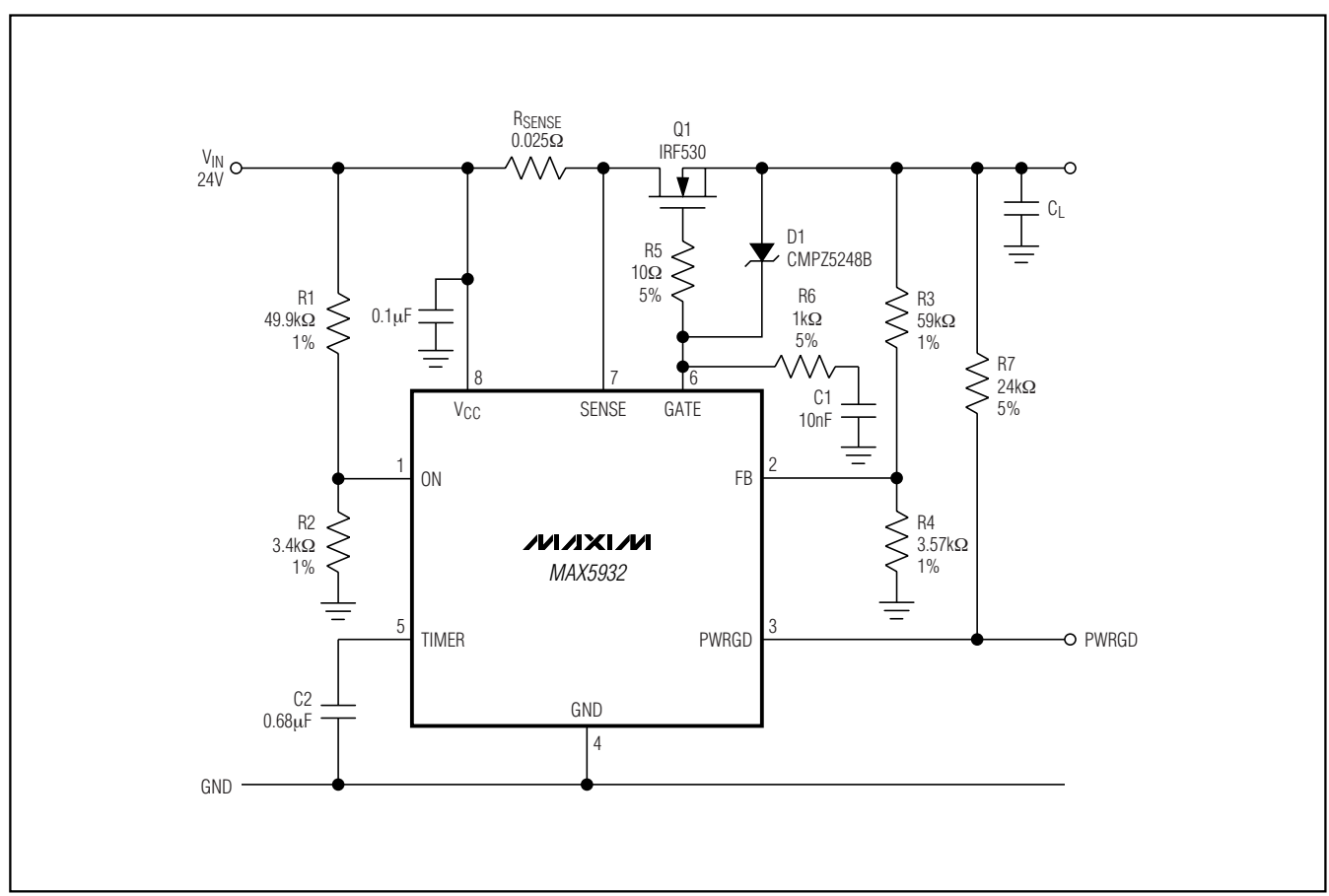

Figure 5. Application Circuit

# Positive High-Voltage, Hot-Swap Controller

## Applications Information

### Hot-Circuit Insertion

When circuit boards are inserted into a live backplane, the supply bypass capacitors on the boards draw high peak currents from the backplane power bus as they charge up. The transient currents can permanently damage the connector pins and glitch the system supply, causing other boards in the system to reset.

### Power-Up Sequence

The power supply on a board is controlled by placing an external n-channel MOSFET (Q1) in the power path (Figure 5). Resistor R<sub>SENSE</sub> provides current detection and capacitor C1 provides control of the GATE slew rate. Resistor R6 provides current control-loop compensation while R5 prevents high-frequency oscillations in Q1. Resistors R1 and R2 provide undervoltage sensing.

After the power pins first make contact, transistor Q1 is turned off. When the voltage at ON exceeds the turn-on threshold voltage, the voltage on V<sub>CC</sub> exceeds the under-voltage lockout threshold, and the voltage on TIMER is less than 1.233V, transistor Q1 turns on (Figure 6).

The voltage at GATE rises with a slope equal to  $10\mu\text{A}/\text{C1}$  and the supply inrush current is set at:

$$I_{\text{INRUSH}} = C_L \times 10\mu\text{A}/\text{C1}$$

When the voltage across the current-sense resistor R<sub>SENSE</sub> reaches V<sub>SENSETRIP</sub>, then the inrush current is limited by the internal current-limit circuitry that adjusts the voltage on GATE to maintain a constant voltage across the sense resistor.

Once the voltage at the output has reached its final value, as sensed by resistors R3 and R4, PWRGD goes high.

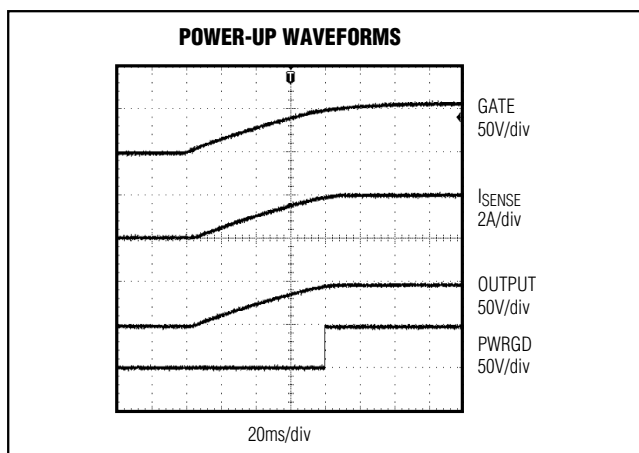

Figure 6. Power-Up Waveforms

### Short-Circuit Protection

The MAX5932 features a programmable foldback current limit with an electronic circuit breaker that protects against short circuits or excessive supply currents. The current limit is set by placing a sense resistor between V<sub>CC</sub> (pin 8) and SENSE (pin 7).

To prevent excessive power dissipation in the pass transistor and to prevent voltage spikes on the input supply during short-circuit conditions at the output, the current folds back as a function of the output voltage that is sensed at FB (Figure 7).

When the voltage at FB is 0V, the current-limit circuit drives GATE to force a constant 12mV drop across the sense resistor. As the output voltage at FB increases, the voltage across the sense resistor increases until FB reaches 0.5V, at the point that the voltage across the sense resistor is held constant at 47mV.

The maximum current limit is calculated as:

$$I_{\text{LIMIT}} = 47\text{mV}/R_{\text{SENSE}}$$

For a 0.025Ω sense resistor, the current limit is set at 1.88A and folds back to 480mA when the output is shorted to ground.

The MAX5932 also features a variable overcurrent response time. The time required to regulate Q1's drain current depends on:

- Q1's input capacitance.
- GATE capacitor C1 and compensation resistor R6.
- The internal delay from SENSE to GATE.

Figure 8 shows the delay from a voltage step at SENSE until GATE voltage starts falling, as a function of overdrive.

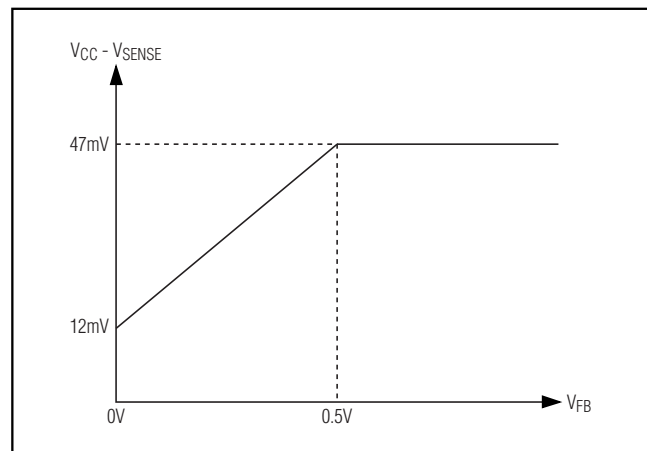

Figure 7. Current-Limit Sense Voltage vs. Feedback Voltage

# Positive High-Voltage, Hot-Swap Controller

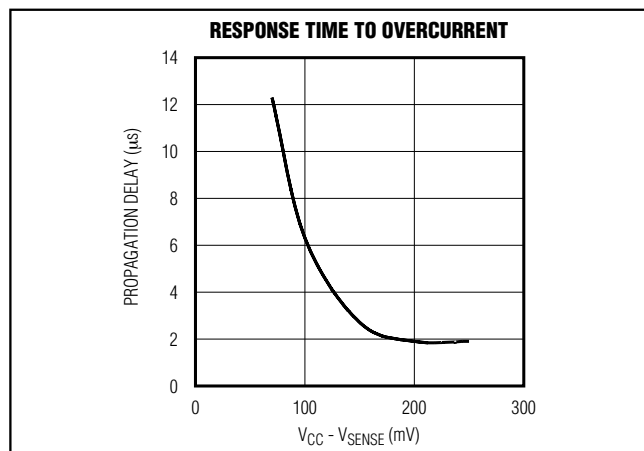

Figure 8. Response Time to Overcurrent

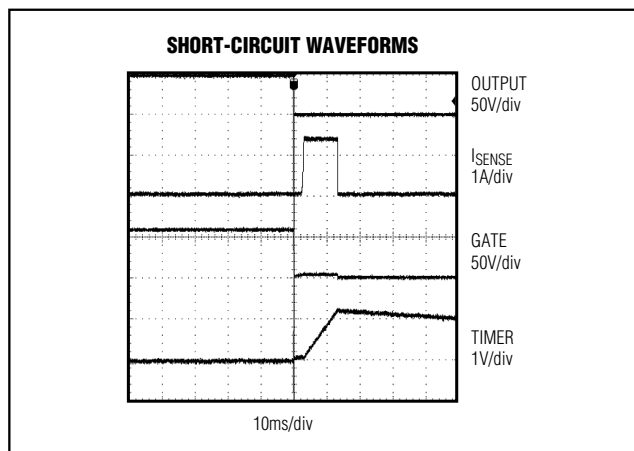

Figure 9. Short-Circuit Waveforms

## TIMER

TIMER provides a method for programming the maximum time the device is allowed to operate in current limit. When the current-limit circuitry is not active, TIMER is pulled to GND by a  $3\mu\text{A}$  current source. After the current-limit circuit becomes active, an  $80\mu\text{A}$  pullup current source is connected to TIMER and the voltage rises with a slope equal to  $77\mu\text{A}/C_{\text{TIMER}}$  as long as the current-limit circuit remains active. Once the desired maximum current-limit time is chosen, the capacitor value is calculated using the following equations:

$$C(\text{nF}) = 65 \times t(\text{ms})$$

or

$$T_{\text{LIMIT}} = (C_{\text{TIMER}}/80\mu\text{A}) \times 1.233\text{V}$$

When the current-limit circuit turns off, TIMER is discharged to GND by the  $3\mu\text{A}$  current source.

Whenever TIMER reaches 1.233V, the internal fault latch is set. GATE is immediately pulled to GND and TIMER is pulled back to GND by the  $3\mu\text{A}$  current source. When TIMER falls below 0.5V, ON is pulsed low to reset the internal fault latch.

The waveform in Figure 9 shows how the output latches off following a short circuit. The drop across the sense resistor is held at 12mV as the timer ramps up. Since the output did not rise, FB remains below 0.5V and the circuit latches off. For Figure 9,  $C_T = 100\text{nF}$ .

## Undervoltage and Overvoltage Detection

ON can be used to detect an undervoltage condition at the power-supply input. ON is internally connected to an analog comparator with 80mV of hysteresis. If ON falls below its threshold voltage (1.233V), GATE is pulled low and is held low until ON is high again.

Figure 10 shows an overvoltage detection circuit. When the input voltage exceeds the Zener diode's breakdown voltage, D1 turns on and starts to pull TIMER high. After TIMER is pulled higher than 1.233V, the fault latch is set and GATE is pulled to GND immediately, turning off transistor Q1 (see Figure 11). Operation is restored either by interrupting power or by pulsing ON low.

## Power-Good Detection

The MAX5932 includes a comparator for monitoring the output voltage. The noninverting input (FB) is compared against an internal 1.233V precision reference and exhibits 80mV hysteresis. The comparator's output (PWRGD) is an open drain one capable of operating from a pullup as high as 80V.

The PWRGD can be used to directly enable/disable a power module with an active-high enable input. Figure 12 shows how to use PWRGD to control an active-low enable-input power module. Signal inversion is accomplished by transistor Q2 and R7 or use MAX5933.

## Supply Transient Protection

The MAX5932 is 100% tested and guaranteed to be safe from damage with supply voltages up to 80V. However, spikes above 85V may damage the device. During a short-circuit condition, the large change in currents flowing through the power-supply traces can cause inductive voltage spikes that could exceed 85V. To minimize the spikes, the power-trace parasitic inductance should be minimized by using wider traces or heavier trace plating and a  $0.1\mu\text{F}$  bypass capacitor placed between  $V_{CC}$  and GND. A transient voltage suppressor (TVS) at the input can also prevent damage from voltage surges.

# Positive High-Voltage, Hot-Swap Controller

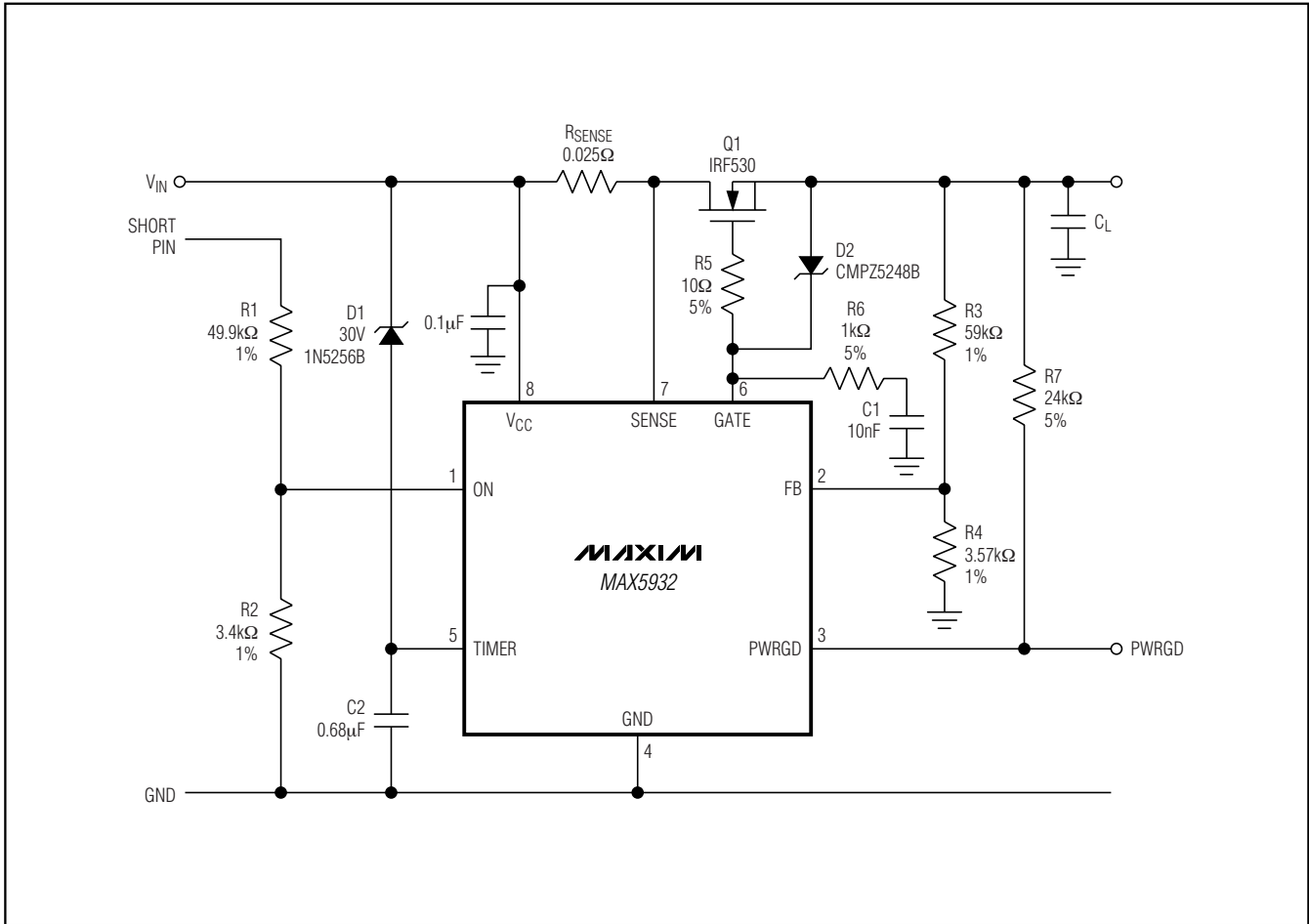

Figure 10. Overvoltage Detection

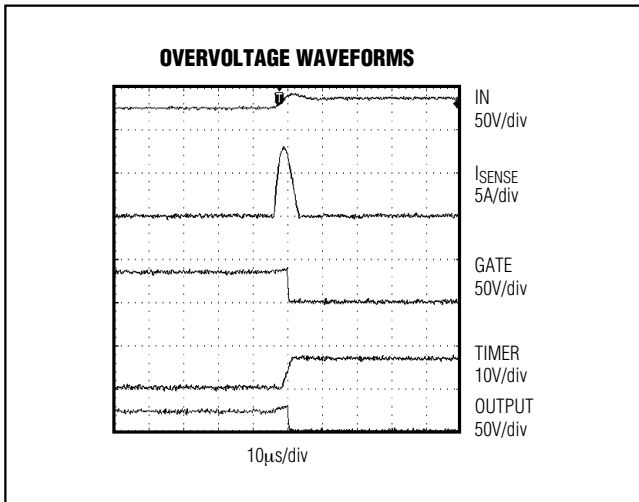

Figure 11. Overvoltage Waveforms

## GATE Voltage

A curve of Gate Drive vs.  $V_{CC}$  is shown in Figure 13. GATE is clamped to a maximum voltage of 18V above the input voltage. At a minimum input-supply voltage of 9V, the minimum gate-drive voltage is 4.5V. When the input-supply voltage is higher than 20V, the gate-drive voltage is at least 10V and a standard n-channel MOSFET can be used. In applications over a 9V to 20V range, a logic-level n-FET must be used with a proper protection Zener diode between its gate and source (as D1 shown in Figure 5).

## Thermal Shutdown

If the MAX5932 die temperature reaches +150°C, an overtemperature fault is generated. As a result, GATE goes low and turns the external MOSFET off. The MAX5932 die temperature must cool down below +130°C before the overtemperature fault condition is removed.

# Positive High-Voltage, Hot-Swap Controller

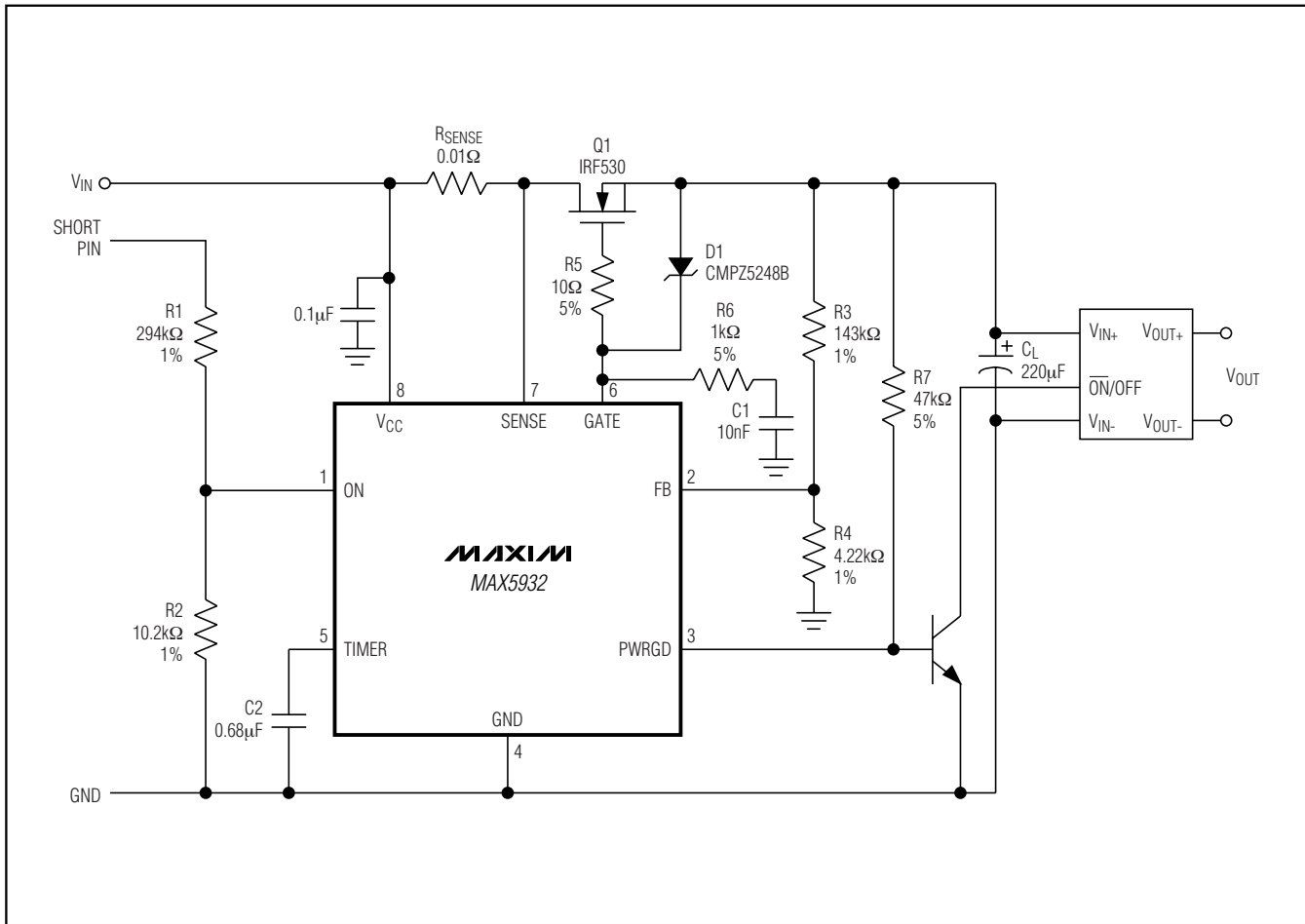

Figure 12. Active-Low Enable Module

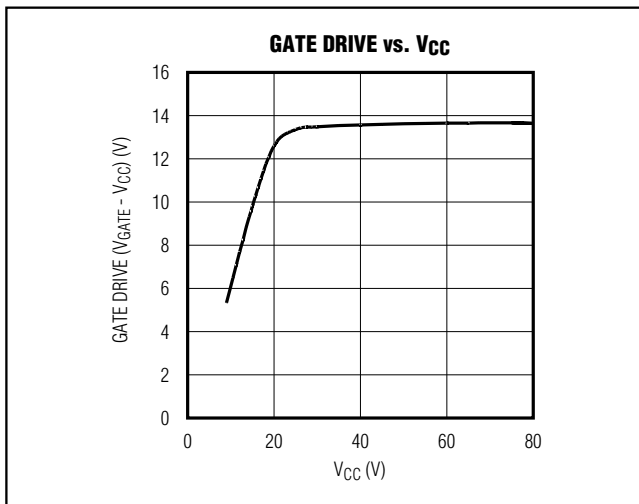

Figure 13. Gate Drive vs. Supply Voltage

### Layout Considerations

To achieve accurate current sensing, a Kelvin connection is recommended. The minimum trace width for 1oz copper foil is 0.02in per amplifier to make sure the trace stays at a reasonable temperature. Using 0.03in per amplifier or wider is recommended. Note that 1oz copper exhibits a sheet resistance of about 530μΩ/square. Small resistances add up quickly in high-current applications. To improve noise immunity, connect the resistor-divider to ON close to the device and keep traces to V<sub>CC</sub> and GND short. A 0.1μF capacitor from ON to GND also helps reject induced noise. Figure 14 shows a layout that addresses these issues.

External MOSFET must be thermally coupled to the MAX5932 to ensure proper thermal shutdown operation (see Figure 14).

# Positive High-Voltage, Hot-Swap Controller

## Chip Information

TRANSISTOR COUNT: 1573  
 PROCESS: BICMOS

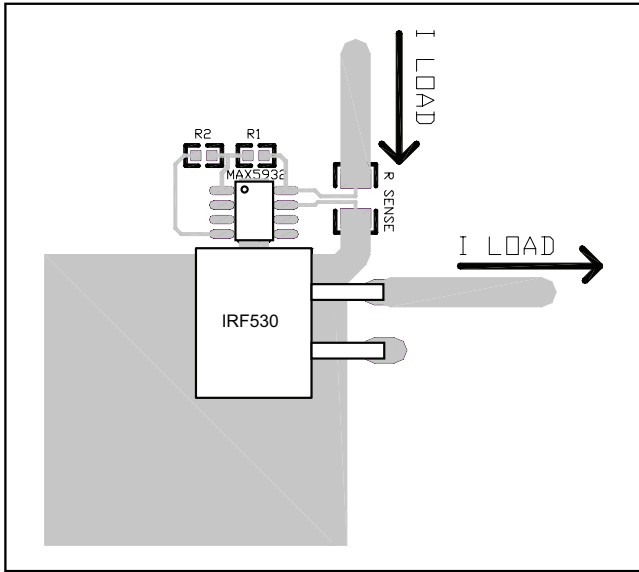
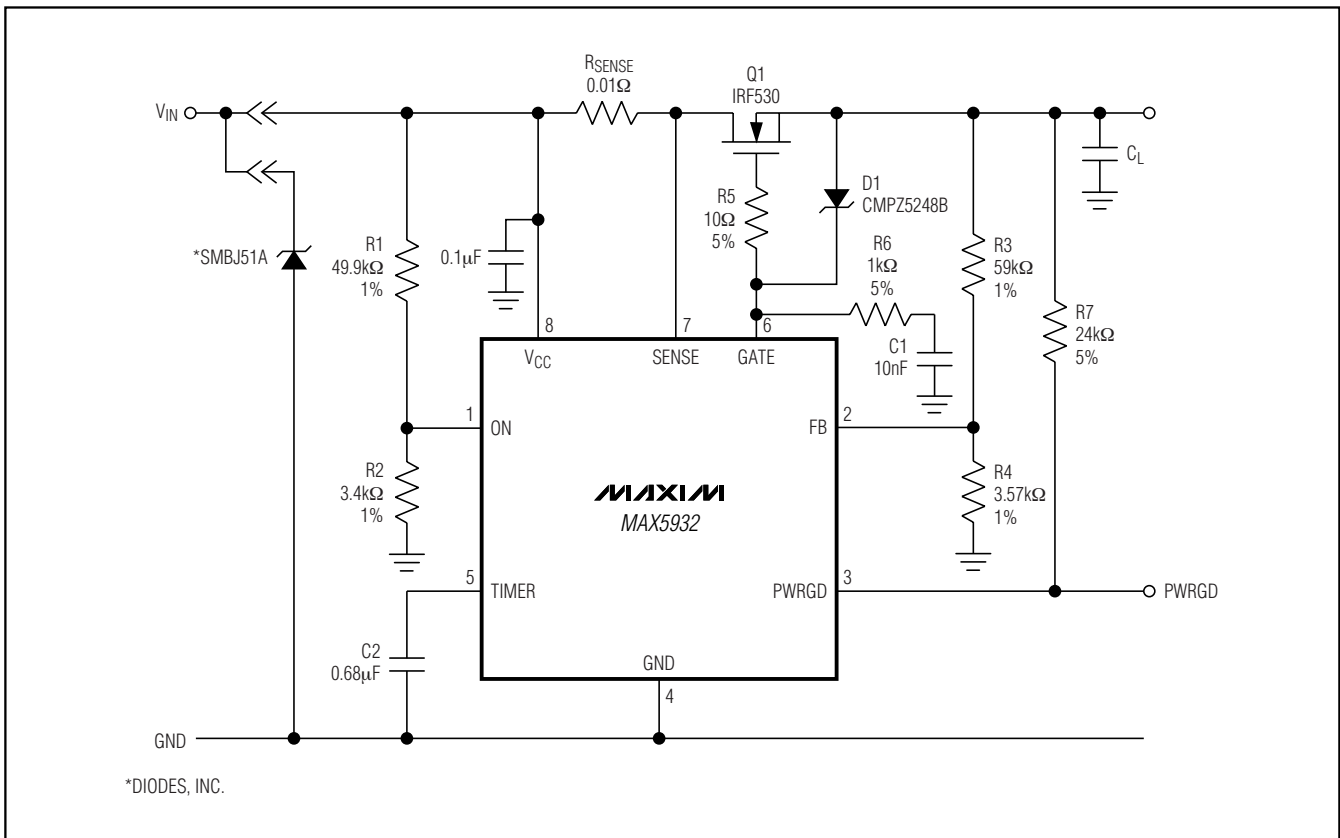

Figure 14. Recommended Layout for R1, R2, and RSENSE

## Typical Application Circuit



# Positive High-Voltage, Hot-Swap Controller

## Package Information

(The package drawing(s) in this data sheet may not reflect the most current specifications. For the latest package outline information go to [www.maxim-ic.com/packages](http://www.maxim-ic.com/packages).)

**MAX5932**

SOICN, EPS

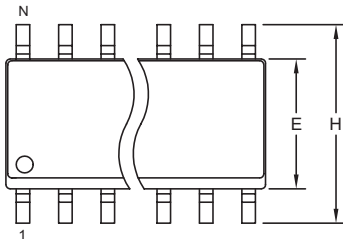

TOP VIEW

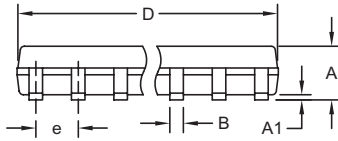

FRONT VIEW

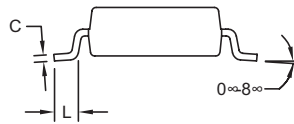

SIDE VIEW

DIM	INCHES		MILLIMETERS	
	MIN	MAX	MIN	MAX
A	0.053	0.069	1.35	1.75
A1	0.004	0.010	0.10	0.25
B	0.014	0.019	0.35	0.49
C	0.007	0.010	0.19	0.25
e	0.050 BSC		1.27 BSC	
E	0.150	0.157	3.80	4.00
H	0.228	0.244	5.80	6.20
L	0.016	0.050	0.40	1.27

VARIATIONS:

DIM	INCHES		MILLIMETERS		N	MS012
	MIN	MAX	MIN	MAX		
D	0.189	0.197	4.80	5.00	8	AA
D	0.337	0.344	8.55	8.75	14	AB
D	0.386	0.394	9.80	10.00	16	AC

**NOTES:**

1. D&E DO NOT INCLUDE MOLD FLASH.
2. MOLD FLASH OR PROTRUSIONS NOT TO EXCEED 0.15mm (.006").
3. LEADS TO BE COPLANAR WITHIN 0.10mm (.004").
4. CONTROLLING DIMENSION: MILLIMETERS.
5. MEETS JEDEC MS012.
6. N = NUMBER OF PINS.



<small>PROPRIETARY INFORMATION</small>		
TITLE: <b>PACKAGE OUTLINE, .150" SOIC</b>		
APPROVAL	DOCUMENT CONTROL NO. 21-0041	REV. B 1/1

Maxim cannot assume responsibility for use of any circuitry other than circuitry entirely embodied in a Maxim product. No circuit patent licenses are implied. Maxim reserves the right to change the circuitry and specifications without notice at any time.

**Maxim Integrated Products, 120 San Gabriel Drive, Sunnyvale, CA 94086 408-737-7600** \_\_\_\_\_ **15**

## Looking for pricing, stock, or lifecycle information?

Click below to explore more details on WIN SOURCE:

-  [View MAX5932ESA+T on WIN SOURCE](#)
-  [Maxim Integrated Information](#)

## Optimize Your Supply Chain with WIN SOURCE Solutions

-  Global Sourcing Solution
-  Obsolete Management
-  Cost Control Management
-  Shortage Management
-  Alternative Solution
-  Excess Inventory Management