



**THE DATASHEET OF  
SN65LBC174ADWR**



## QUADRUPLE RS-485 DIFFERENTIAL LINE DRIVERS

 Check for Samples: [SN65LBC174A](#) [SN75LBC174A](#)

### FEATURES

- Designed for TIA/EIA-485, TIA/EIA-422 and ISO 8482 Applications
- Signaling Rates <sup>(1)</sup> up to 30 Mbps
- Propagation Delay Times < 11 ns
- Low Standby Power Consumption 1.5-mA Max

(1) The signaling rate of a line is the number of voltage transitions that are made per second expressed in the units bps (bits per second).

- Output ESD Protection: 12 kV
- Driver Positive- and Negative-Current Limiting
- Power-Up and Power-Down Glitch-Free for Line Insertion Applications
- Thermal Shutdown Protection
- Industry Standard Pin-Out, Compatible With SN75174, MC3487, DS96174, LTC487, and MAX3042

### DESCRIPTION

The SN65LBC174A and SN75LBC174A are quadruple differential line drivers with 3-state outputs, designed for TIA/EIA-485 (RS-485), TIA/EIA-422 (RS-422), and ISO 8482 applications.

These devices are optimized for balanced multipoint bus transmission at signaling rates up to 30 million bits per second. The transmission media may be printed-circuit board traces, backplanes, or cables. The ultimate rate and distance of data transfer is dependent upon the attenuation characteristics of the media and the noise coupling to the environment.

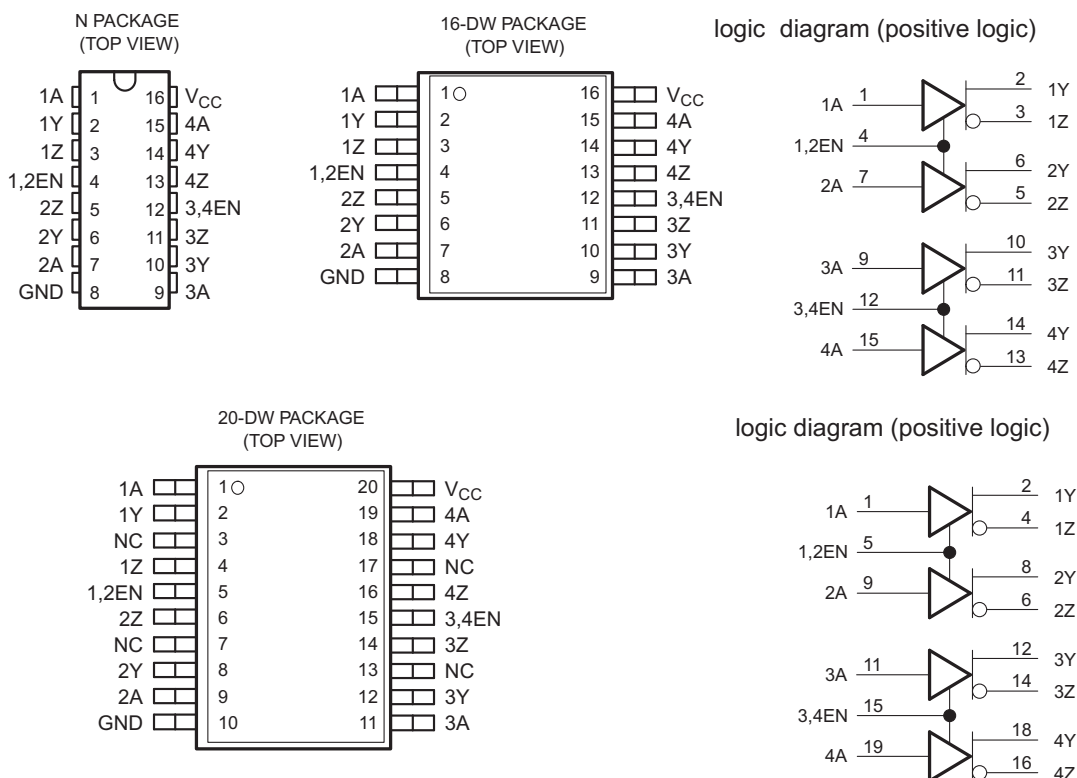

Please be aware that an important notice concerning availability, standard warranty, and use in critical applications of Texas Instruments semiconductor products and disclaimers thereto appears at the end of this data sheet.

LinBiCMOS is a registered trademark of Texas Instruments.



This integrated circuit can be damaged by ESD. Texas Instruments recommends that all integrated circuits be handled with appropriate precautions. Failure to observe proper handling and installation procedures can cause damage.

ESD damage can range from subtle performance degradation to complete device failure. Precision integrated circuits may be more susceptible to damage because very small parametric changes could cause the device not to meet its published specifications.

## DESCRIPTION (CONTINUED)

Each driver features current limiting and thermal-shutdown circuitry making it suitable for high-speed multipoint applications in noisy environments. These devices are designed using LinBiCMOS<sup>®</sup>, facilitating low power consumption and robustness.

The two EN inputs provide pair-wise driver enabling, or can be externally tied together to provide enable control of all four drivers with one signal. When disabled or powered off, the driver outputs present a high-impedance to the bus for reduced system loading.

The SN75LBC174A is characterized for operation over the temperature range of 0°C to 70°C. The SN65LBC174A is characterized for operation over the temperature range of –40°C to 85°C.

**Table 1. AVAILABLE OPTIONS**

T <sub>A</sub>	PACKAGE		
	16-PIN PLASTIC SMALL OUTLINE <sup>(1)</sup> (JEDEC MS-013)	20-PIN PLASTIC SMALL OUTLINE <sup>(1)</sup> (JEDEC MS-013)	16-PIN PLASTIC THROUGH-HOLE (JEDEC MS-001)
0°C to 70°C	SN75LBC174A16DW	SN75LBC174ADW	SN75LBC174AN
	MARKED AS 75LBC174A		
–40°C to 85°C	SN65LBC174A16DW	SN65LBC174DW	SN65LBC174AN
	MARKED AS 65LBC174A		

(1) Add R suffix for taped and reeled version.

**Table 2. FUNCTION TABLE (EACH DRIVER)<sup>(1)</sup>**

INPUT A	ENABLE EN	OUTPUT Y	OUTPUT Z
L	H	L	H
H	H	H	L
OPEN	H	H	L
L	OPEN	L	H
H	OPEN	H	L
OPEN	OPEN	H	L
X	L	Z	Z

(1) H = high level, L = low level, X = irrelevant, Z = high impedance (off)

## ABSOLUTE MAXIMUM RATINGS

over operating free-air temperature range (unless otherwise noted)<sup>(1)</sup>

			VALUE / UNIT
Supply voltage range, $V_{CC}$ <sup>(2)</sup>			–0.3 V to 6 V
Voltage range at any bus (DC)			–10 V to 15 V
Voltage range at any bus (transient pulse through 100 $\Omega$ , see <a href="#">Figure 8</a> )			–30 V to 30 V
Input voltage range at any A or EN terminal, $V_I$			–0.5 V to $V_{CC} + 0.5$ V
Electrostatic discharge	Human body model <sup>(3)</sup>	Y, Z, and GND	$\pm 12$ kV
		All pins	$\pm 5$ kV
	Charged-device model <sup>(4)</sup>	All pins	$\pm 1$ kV
Storage temperature range, $T_{stg}$			–65°C to 150°C
Continuous power dissipation			See Dissipation Rating Table

- (1) Stresses beyond those listed under *Absolute Maximum Ratings* may cause permanent damage to the device. These are stress ratings only, and functional operation of the device at these or any other conditions beyond those indicated under *Recommended Operating Conditions* is not implied. Exposure to absolute-maximum-rated conditions for extended periods may affect device reliability.
- (2) All voltage values, except differential I/O bus voltages, are with respect to GND.
- (3) Tested in accordance with JEDEC standard 22, Test Method A114-A.
- (4) Tested in accordance with JEDEC standard 22, Test Method C101.

**Table 3. DISSIPATION RATING TABLE**

PACKAGE <sup>(1)</sup>	JEDEC BOARD MODEL	$T_A \leq 25^\circ\text{C}$ POWER RATING	DERATING FACTOR <sup>(2)</sup> ABOVE $T_A = 25^\circ\text{C}$	$T_A = 70^\circ\text{C}$ POWER RATING	$T_A = 85^\circ\text{C}$ POWER RATING
16 DW	LOW K	1200 mW	9.6 mW/°C	769 mW	625 mW
	HIGH K	2240 mW	17.9 mW/°C	1434 mW	1165 mW
20 DW	LOW K	1483 mW	11.86 mW/°C	949 mW	771 mW
	HIGH K	2753 mW	22 mW/°C	1762 mW	1432 mW
16 N	LOW K	1150 mW	9.2 mW/°C	736 mW	598 mW

- (1) For the most current package and ordering information, see the Package Option Addendum at the end of this document, or see the TI website at [www.ti.com](http://www.ti.com).
- (2) This is the inverse of the junction-to-ambient thermal resistance when board-mounted and with no air flow.

## RECOMMENDED OPERATING CONDITIONS

		MIN	NOM	MAX	UNIT
Supply voltage, $V_{CC}$		4.75	5	5.25	V
Voltage at any bus terminal	Y, Z	–7		12	V
High-level input voltage, $V_{IH}$	A, EN	2		$V_{CC}$	V
Low-level input voltage, $V_{IL}$		0		0.8	
Output current		–60		60	mA
Operating free-air temperature, $T_A$	SN75LBC174A	0		70	°C
	SN65LBC174A	–40		85	

## ELECTRICAL CHARACTERISTICS

over recommended operating conditions

PARAMETER		TEST CONDITIONS	MIN	TYP <sup>(1)</sup>	MAX	UNIT
V <sub>IK</sub>	Input clamp voltage	I <sub>I</sub> = -18 mA	-1.5	-0.77		V
V <sub>O</sub>	Open-circuit output voltage	Y or Z, No load	0		V <sub>CC</sub>	V
V <sub>OD(SS)</sub>	Steady-state differential output voltage magnitude <sup>(2)</sup>	No load (open circuit)	3		V <sub>CC</sub>	V
		R <sub>L</sub> = 54 Ω, See <a href="#">Figure 1</a>	1	1.6	2.5	
		With common-mode loading, See <a href="#">Figure 2</a>	1	1.6	2.5	
ΔV <sub>OD(SS)</sub>	Change in steady-state differential output voltage between logic states	See <a href="#">Figure 1</a>	-0.1		0.1	V
V <sub>OC(SS)</sub>	Steady-state common-mode output voltage	See <a href="#">Figure 3</a>	2	2.4	2.8	V
ΔV <sub>OC(SS)</sub>	Change in steady-state common-mode output voltage between logic states	See <a href="#">Figure 3</a>	-0.02		0.02	V
I <sub>I</sub>	Input current	A, EN	-50		50	μA
I <sub>OS</sub>	Short-circuit output current	V <sub>TEST</sub> = -7 V to 12 V, See <a href="#">Figure 7</a>	-200	V <sub>I</sub> = 0 V	200	mA
I <sub>OZ</sub>	High-impedance-state output current			V <sub>I</sub> = V <sub>CC</sub>		
I <sub>O(OFF)</sub>	Output current with power off	EN at 0 V	-50		50	μA
I <sub>CC</sub>	Supply current	V <sub>I</sub> = 0 V or V <sub>CC</sub> , No load		V <sub>CC</sub> = 0 V	10	mA
				All drivers enabled	23	
C <sub>IN</sub>	Input Capacitance	A inputs		13		pF
		EN inputs		21		pF

(1) All typical values are at V<sub>CC</sub> = 5 V and 25°C.

(2) The minimum V<sub>OD</sub> may not fully comply with TIA/EIA-485-A at operating temperatures below 0°C. System designers should take the possibly lower output signal into account in determining the maximum signal transmission distance.

## SWITCHING CHARACTERISTICS

over recommended operating conditions

PARAMETER	TEST CONDITIONS	MIN	TYP	MAX	UNIT
t <sub>PLH</sub>	Propagation delay time, low-to-high level output	5.5	8	11	ns
t <sub>PHL</sub>	Propagation delay time, high-to-low level output	5.5	8	11	ns
t <sub>r</sub>	Differential output voltage rise time	3	7.5	11	ns
t <sub>f</sub>	Differential output voltage fall time	3	7.5	11	ns
t <sub>sk(p)</sub>	Pulse skew  t <sub>PLH</sub> - t <sub>PHL</sub>		0.6	2	ns
t <sub>sk(o)</sub>	Output skew <sup>(1)</sup>		0.6	2	
t <sub>sk(pp)</sub>	Part-to-part skew <sup>(2)</sup>			2	ns
t <sub>PZH</sub>	Propagation delay time, high-impedance-to-high-level output			25	ns
t <sub>PHZ</sub>	Propagation delay time, high-level-output-to-high impedance	See <a href="#">Figure 5</a>		25	
t <sub>PZL</sub>	Propagation delay time, high-impedance-to-low-level output			30	ns
t <sub>PLZ</sub>	Propagation delay time, low-level-output-to-high impedance	See <a href="#">Figure 6</a>		20	

(1) Output skew (t<sub>sk(o)</sub>) is the magnitude of the time delay difference between the outputs of a single device with all of the inputs connected together.

(2) Part-to-part skew (t<sub>sk(pp)</sub>) is the magnitude of the difference in propagation delay times between any specified terminals of two devices when both devices operate with the same input signals, the same supply voltages, at the same temperature, and have identical packages and test circuits.

PARAMETER MEASUREMENT INFORMATION

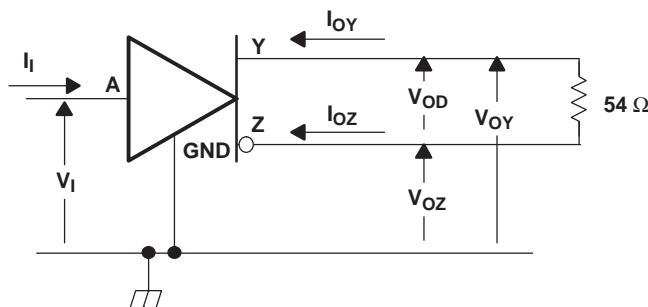

Figure 1. Test Circuit,  $V_{OD}$  Without Common-Mode Loading

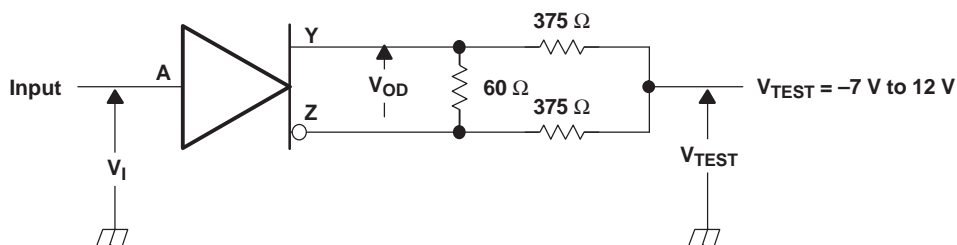
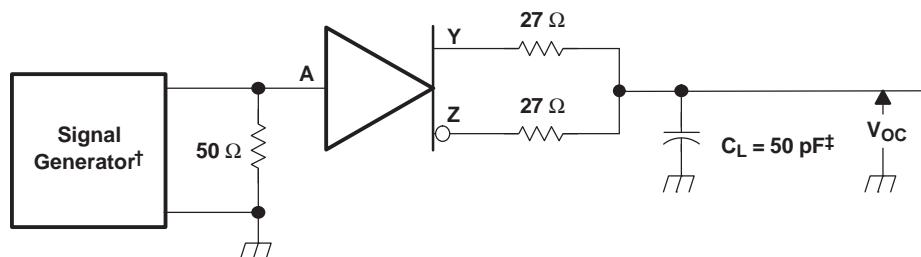

Figure 2. Test Circuit,  $V_{OD}$  With Common-Mode Loading



† PRR = 1 MHz, 50% Duty Cycle,  $t_r < 6$  ns,  $t_f < 6$  ns,  $Z_O = 50 \Omega$

‡ Includes probe and jig capacitance

Figure 3.  $V_{OC}$  Test Circuit

PARAMETER MEASUREMENT INFORMATION (continued)

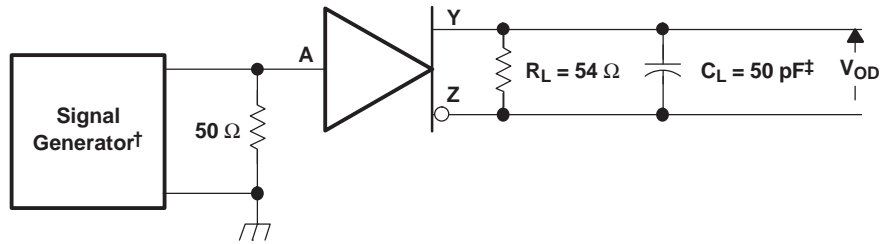

† PRR = 1 MHz, 50% Duty Cycle,  $t_r < 6$  ns,  $t_f < 6$  ns,  $Z_O = 50 \Omega$

‡ Includes probe and jig capacitance

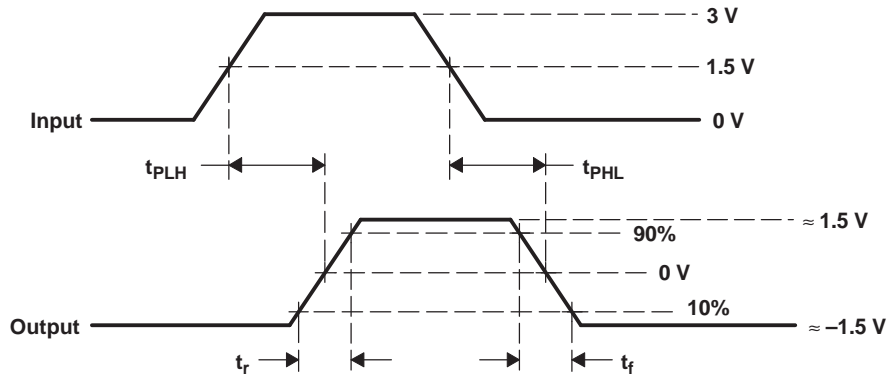
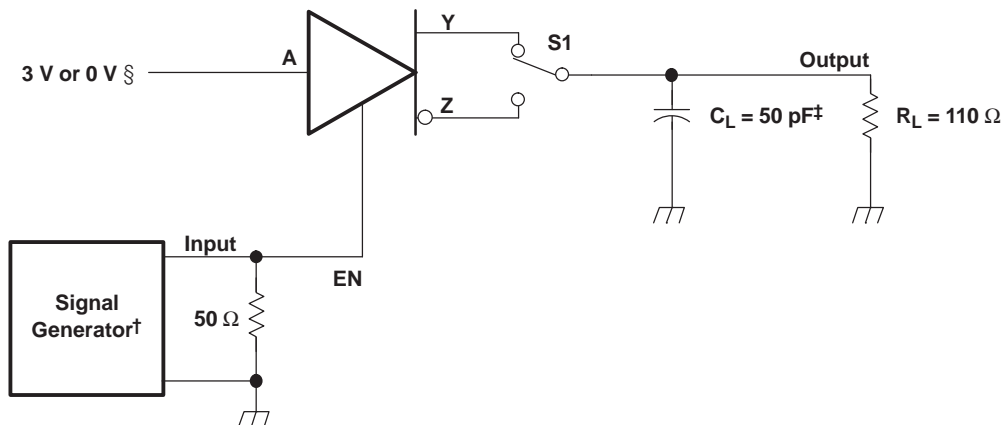

Figure 4. Output Switching Test Circuit and Waveforms

PARAMETER MEASUREMENT INFORMATION (continued)



† PRR = 1 MHz, 50% Duty Cycle,  $t_r < 6$  ns,  $t_f < 6$  ns,  $Z_O = 50 \Omega$

‡ Includes probe and jig capacitance

§ 3 V if testing Y output, 0 V if testing Z output

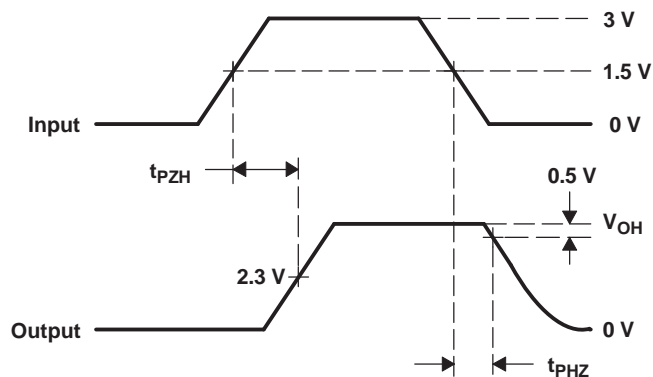
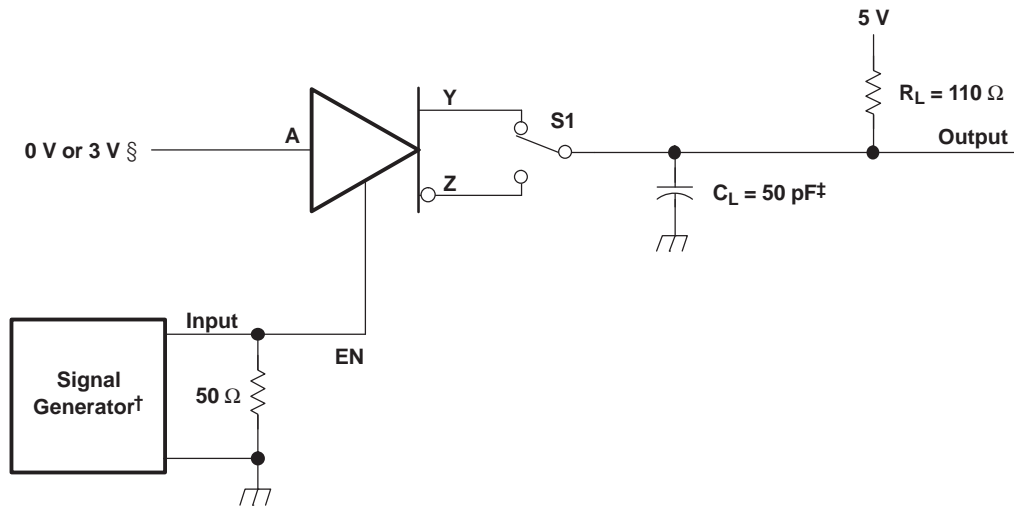

Figure 5. Enable Timing Test Circuit and Waveforms,  $t_{PZH}$  and  $t_{PHZ}$

PARAMETER MEASUREMENT INFORMATION (continued)



† PRR = 1 MHz, 50% Duty Cycle,  $t_r < 6$  ns,  $t_f < 6$  ns,  $Z_O = 50 \Omega$   
 ‡ Includes probe and jig capacitance  
 § 3 V if testing Y output, 0 V if testing Z output

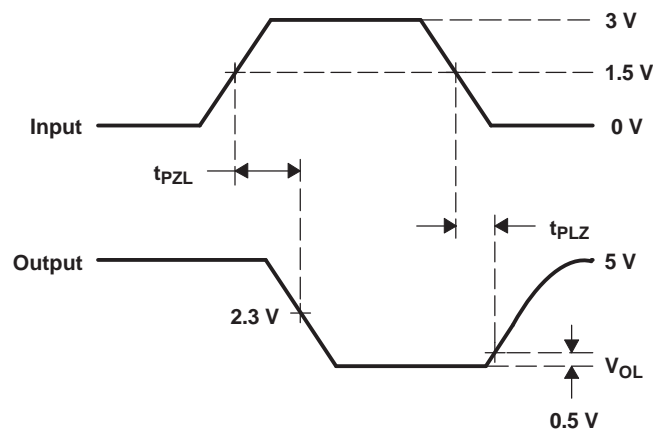

Figure 6. Enable Timing Test Circuit and Waveforms,  $t_{PZL}$  and  $t_{PLZ}$

PARAMETER MEASUREMENT INFORMATION (continued)

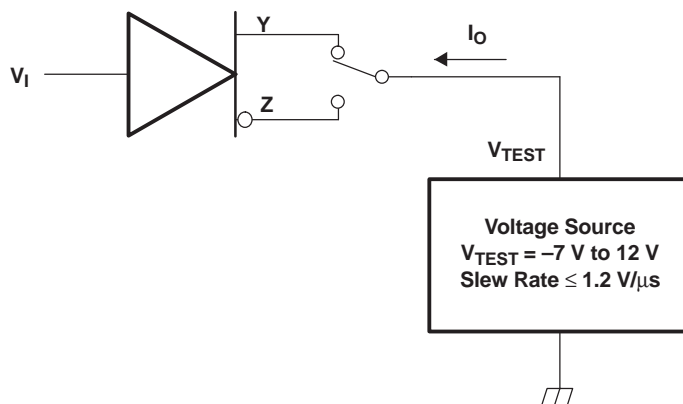

Figure 7. Test Circuit, Short-Circuit Output Current

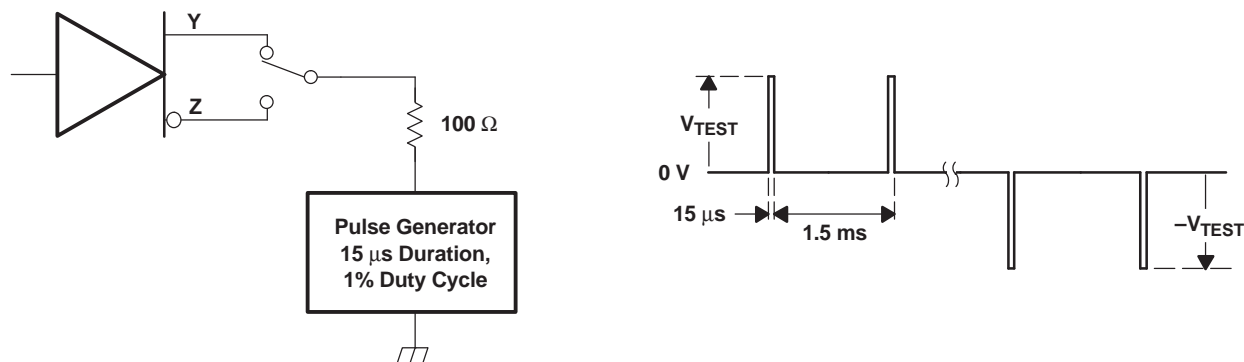
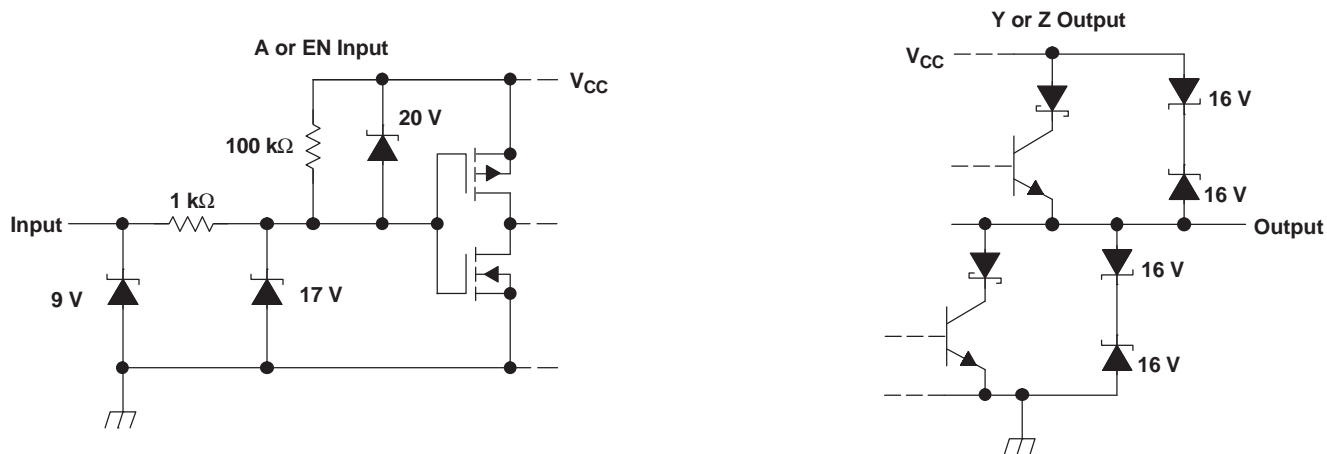

Figure 8. Test Circuit Waveform, Transient Overvoltage Test

EQUIVALENT INPUT AND OUTPUT SCHEMATIC DIAGRAMS



TYPICAL CHARACTERISTICS

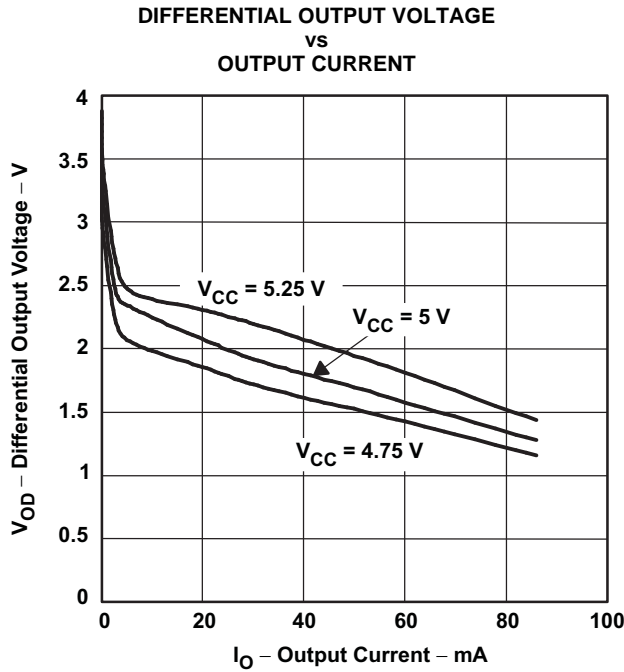

Figure 9.

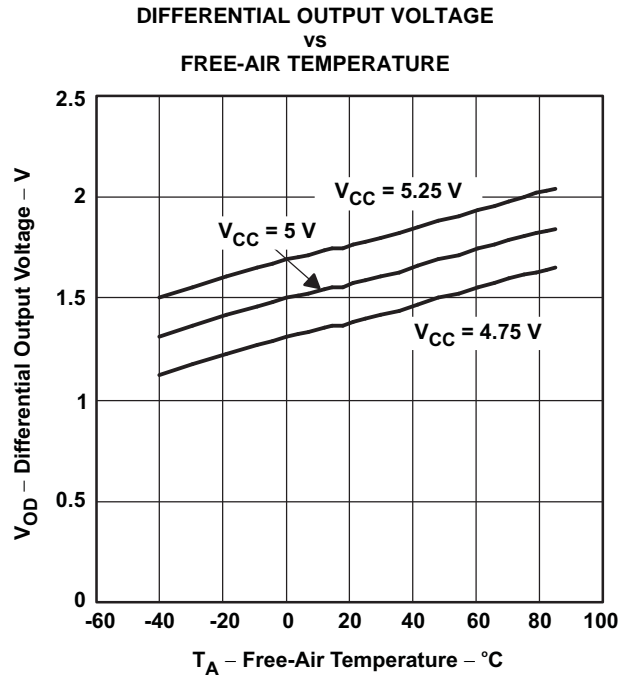

Figure 10.

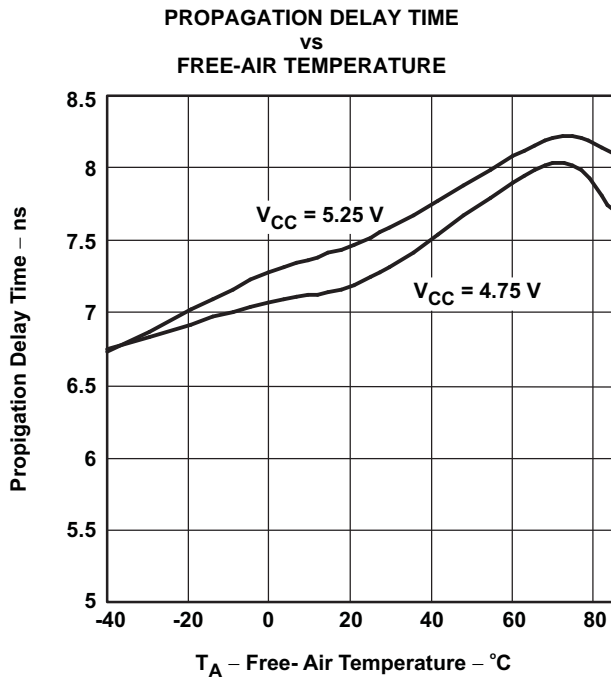

Figure 11.

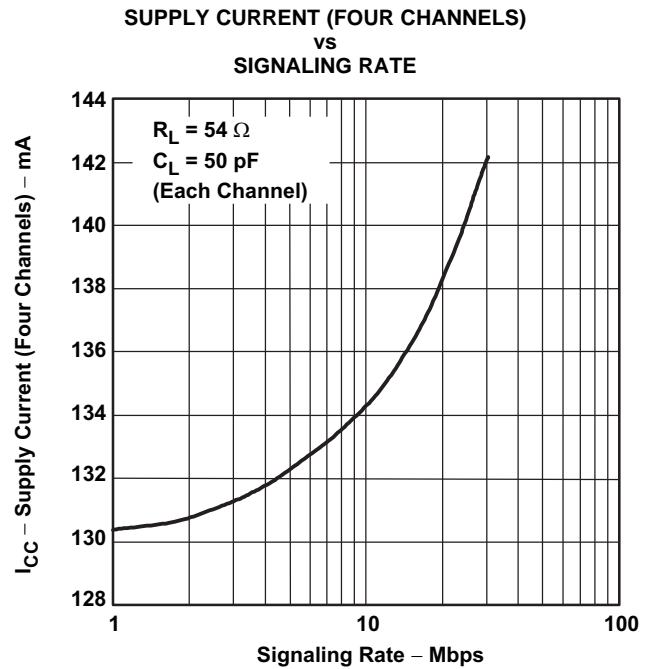

Figure 12.

TYPICAL CHARACTERISTICS (continued)

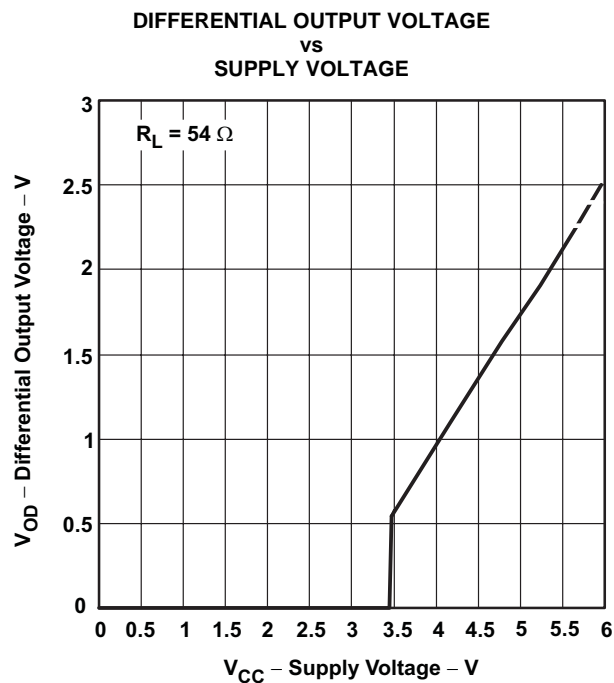

Figure 13.

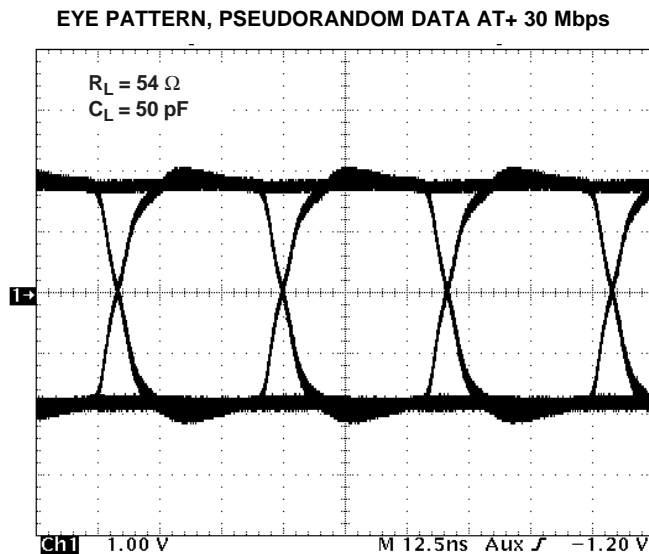

Figure 14.

**APPLICATION INFORMATION**

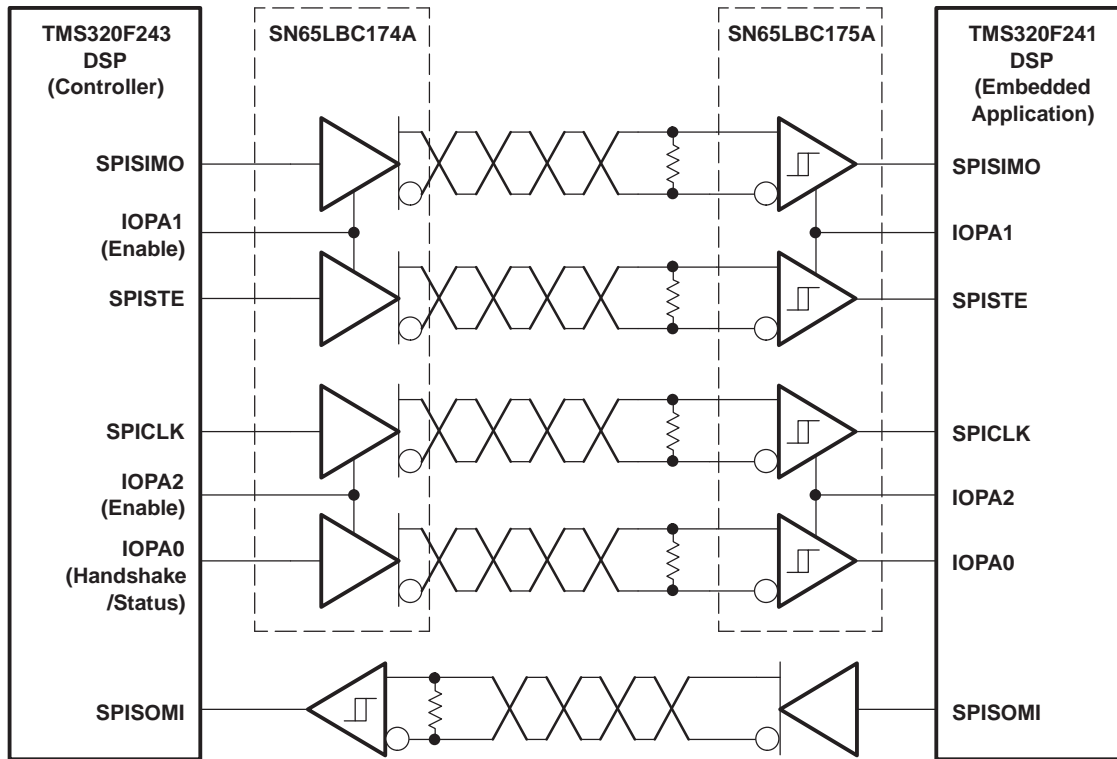

Figure 15. Typical Application Circuit, DSP-to-DSP Link via Serial Peripheral Interface

**REVISION HISTORY**

Changes from Original (October 2000) to Revision A	Page
<ul style="list-style-type: none"> <li>Changed multiple items through the data sheet. .... 1</li> </ul>	1
Changes from Revision A (February 2001) to Revision B	Page
<ul style="list-style-type: none"> <li>Changed DW Package appearance ..... 1</li> <li>Added <a href="#">Figure 13</a> ..... 11</li> </ul>	1 11
Changes from Revision B (June 2001) to Revision C	Page
<ul style="list-style-type: none"> <li>Changed Features bullet From: Output ESD Protection Exceeds 13 kV To: Output ESD Protection: 11 kV ..... 1</li> <li>Changed Features bullet for Industry Standard From: Compatible With SN75174, MC3487, and DS96174 To: Compatible With SN75174, MC3487, DS96174, LTC487, and MAX3042 ..... 1</li> </ul>	1 1
Changes from Revision C (May 2003) to Revision D	Page
<ul style="list-style-type: none"> <li>Changed the AVAILABLE OPTIONS table ..... 2</li> <li>Changed Electrostatic discharge-Human body model-Y, Z, and GND From: 13kV To: 11kV ..... 3</li> <li>Changed the DISSIPATION RATING TABLE ..... 3</li> </ul>	2 3 3

**Changes from Revision D (June 2008) to Revision E**
**Page**

- Changed Features bullet From: Output ESD Protection Exceeds 11 kV To: Output ESD Protection: 12 kV ..... 1
  - Changed Electrostatic discharge-Human body model-Y, Z, and GND From: 11kV To: 12kV ..... 3
  - From: A, G,  $\bar{G}$  To: A, EN ..... 4
- 

**Changes from Revision E (July 2008) to Revision F**
**Page**

- Changed FUNCTION TABLE header From: ENABLE G To: ENABLE EN ..... 2
  - Added  $C_{IN}$  - Input Capacitance to the Electrical Characteristics table ..... 4
  - Changed the location of the EQUIVALENT INPUT AND OUTPUT SCHEMATIC DIAGRAM ..... 9
-

**PACKAGING INFORMATION**

Orderable Device	Status (1)	Package Type	Package Drawing	Pins	Package Qty	Eco Plan (2)	Lead/Ball Finish (6)	MSL Peak Temp (3)	Op Temp (°C)	Device Marking (4/5)	Samples
SN65LBC174A16DW	ACTIVE	SOIC	DW	16	40	Green (RoHS & no Sb/Br)	CU NIPDAU	Level-1-260C-UNLIM	-40 to 85	65LBC174A	<a href="#">Samples</a>
SN65LBC174A16DWR	ACTIVE	SOIC	DW	16	2000	Green (RoHS & no Sb/Br)	CU NIPDAU	Level-1-260C-UNLIM	-40 to 85	65LBC174A	<a href="#">Samples</a>
SN65LBC174A16DWRG4	ACTIVE	SOIC	DW	16	2000	Green (RoHS & no Sb/Br)	CU NIPDAU	Level-1-260C-UNLIM	-40 to 85	65LBC174A	<a href="#">Samples</a>
SN65LBC174ADW	ACTIVE	SOIC	DW	20	25	Green (RoHS & no Sb/Br)	CU NIPDAU	Level-1-260C-UNLIM	-40 to 85	65LBC174A	<a href="#">Samples</a>
SN65LBC174ADWR	ACTIVE	SOIC	DW	20	2000	Green (RoHS & no Sb/Br)	CU NIPDAU	Level-1-260C-UNLIM	-40 to 85	65LBC174A	<a href="#">Samples</a>
SN65LBC174AN	ACTIVE	PDIP	N	16	25	Pb-Free (RoHS)	CU NIPDAU	N / A for Pkg Type	-40 to 85	65LBC174A	<a href="#">Samples</a>
SN75LBC174A16DW	ACTIVE	SOIC	DW	16	40	Green (RoHS & no Sb/Br)	CU NIPDAU	Level-1-260C-UNLIM	0 to 70	75LBC174A	<a href="#">Samples</a>
SN75LBC174A16DWR	ACTIVE	SOIC	DW	16	2000	Green (RoHS & no Sb/Br)	CU NIPDAU	Level-1-260C-UNLIM	0 to 70	75LBC174A	<a href="#">Samples</a>
SN75LBC174ADW	ACTIVE	SOIC	DW	20	25	Green (RoHS & no Sb/Br)	CU NIPDAU	Level-1-260C-UNLIM	0 to 70	75LBC174A	<a href="#">Samples</a>
SN75LBC174ADWR	ACTIVE	SOIC	DW	20	2000	Green (RoHS & no Sb/Br)	CU NIPDAU	Level-1-260C-UNLIM	0 to 70	75LBC174A	<a href="#">Samples</a>
SN75LBC174AN	ACTIVE	PDIP	N	16	25	Pb-Free (RoHS)	CU NIPDAU	N / A for Pkg Type	0 to 70	75LBC174A	<a href="#">Samples</a>

(1) The marketing status values are defined as follows:

**ACTIVE:** Product device recommended for new designs.

**LIFEBUY:** TI has announced that the device will be discontinued, and a lifetime-buy period is in effect.

**NRND:** Not recommended for new designs. Device is in production to support existing customers, but TI does not recommend using this part in a new design.

**PREVIEW:** Device has been announced but is not in production. Samples may or may not be available.

**OBSOLETE:** TI has discontinued the production of the device.

(2) **RoHS:** TI defines "RoHS" to mean semiconductor products that are compliant with the current EU RoHS requirements for all 10 RoHS substances, including the requirement that RoHS substance do not exceed 0.1% by weight in homogeneous materials. Where designed to be soldered at high temperatures, "RoHS" products are suitable for use in specified lead-free processes. TI may reference these types of products as "Pb-Free".

**RoHS Exempt:** TI defines "RoHS Exempt" to mean products that contain lead but are compliant with EU RoHS pursuant to a specific EU RoHS exemption.

**Green:** TI defines "Green" to mean the content of Chlorine (Cl) and Bromine (Br) based flame retardants meet JS709B low halogen requirements of <=1000ppm threshold. Antimony trioxide based flame retardants must also meet the <=1000ppm threshold requirement.

- (3) MSL, Peak Temp. - The Moisture Sensitivity Level rating according to the JEDEC industry standard classifications, and peak solder temperature.
- (4) There may be additional marking, which relates to the logo, the lot trace code information, or the environmental category on the device.
- (5) Multiple Device Markings will be inside parentheses. Only one Device Marking contained in parentheses and separated by a "~" will appear on a device. If a line is indented then it is a continuation of the previous line and the two combined represent the entire Device Marking for that device.
- (6) Lead/Ball Finish - Orderable Devices may have multiple material finish options. Finish options are separated by a vertical ruled line. Lead/Ball Finish values may wrap to two lines if the finish value exceeds the maximum column width.

**Important Information and Disclaimer:**The information provided on this page represents TI's knowledge and belief as of the date that it is provided. TI bases its knowledge and belief on information provided by third parties, and makes no representation or warranty as to the accuracy of such information. Efforts are underway to better integrate information from third parties. TI has taken and continues to take reasonable steps to provide representative and accurate information but may not have conducted destructive testing or chemical analysis on incoming materials and chemicals. TI and TI suppliers consider certain information to be proprietary, and thus CAS numbers and other limited information may not be available for release.

In no event shall TI's liability arising out of such information exceed the total purchase price of the TI part(s) at issue in this document sold by TI to Customer on an annual basis.

**OTHER QUALIFIED VERSIONS OF SN65LBC174A :**

- Enhanced Product: [SN65LBC174A-EP](#)

**NOTE: Qualified Version Definitions:**

- Enhanced Product - Supports Defense, Aerospace and Medical Applications

## TAPE AND REEL INFORMATION



### QUADRANT ASSIGNMENTS FOR PIN 1 ORIENTATION IN TAPE



\*All dimensions are nominal

Device	Package Type	Package Drawing	Pins	SPQ	Reel Diameter (mm)	Reel Width W1 (mm)	A0 (mm)	B0 (mm)	K0 (mm)	P1 (mm)	W (mm)	Pin1 Quadrant
SN65LBC174A16DWR	SOIC	DW	16	2000	330.0	16.4	10.75	10.7	2.7	12.0	16.0	Q1
SN75LBC174A16DWR	SOIC	DW	16	2000	330.0	16.4	10.75	10.7	2.7	12.0	16.0	Q1
SN75LBC174ADWR	SOIC	DW	20	2000	330.0	24.4	10.8	13.3	2.7	12.0	24.0	Q1

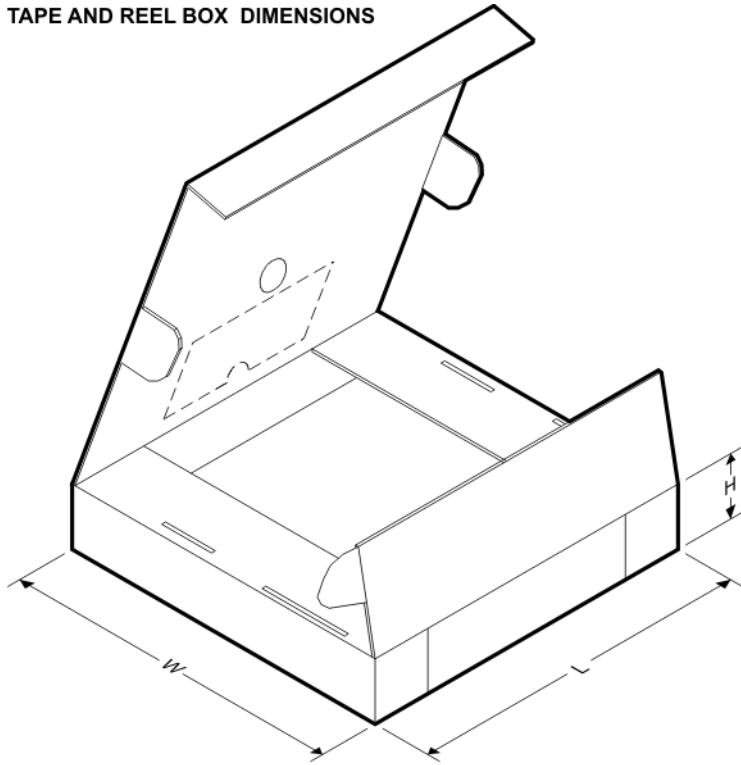
**TAPE AND REEL BOX DIMENSIONS**

\*All dimensions are nominal

Device	Package Type	Package Drawing	Pins	SPQ	Length (mm)	Width (mm)	Height (mm)
SN65LBC174A16DWR	SOIC	DW	16	2000	350.0	350.0	43.0
SN75LBC174A16DWR	SOIC	DW	16	2000	350.0	350.0	43.0
SN75LBC174ADWR	SOIC	DW	20	2000	350.0	350.0	43.0

## GENERIC PACKAGE VIEW

**DW 16**

**SOIC - 2.65 mm max height**

7.5 x 10.3, 1.27 mm pitch

SMALL OUTLINE INTEGRATED CIRCUIT

This image is a representation of the package family, actual package may vary.  
Refer to the product data sheet for package details.

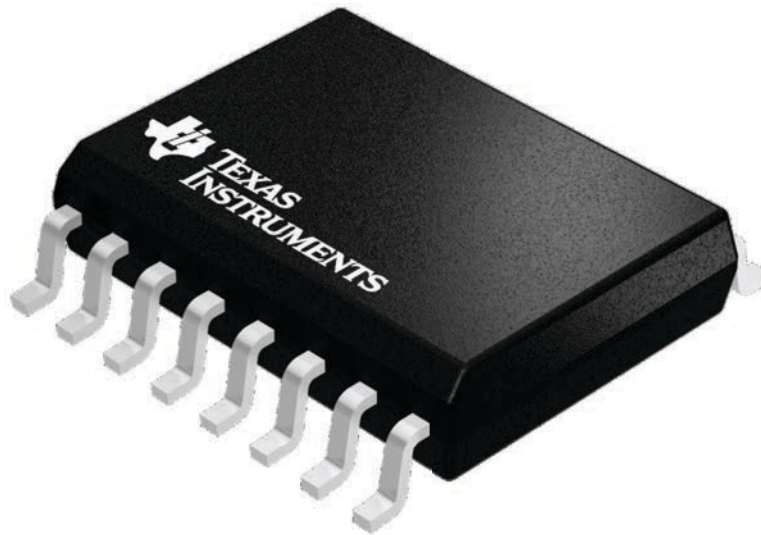

4224780/A



# DW0016A

# PACKAGE OUTLINE

## SOIC - 2.65 mm max height

SOIC

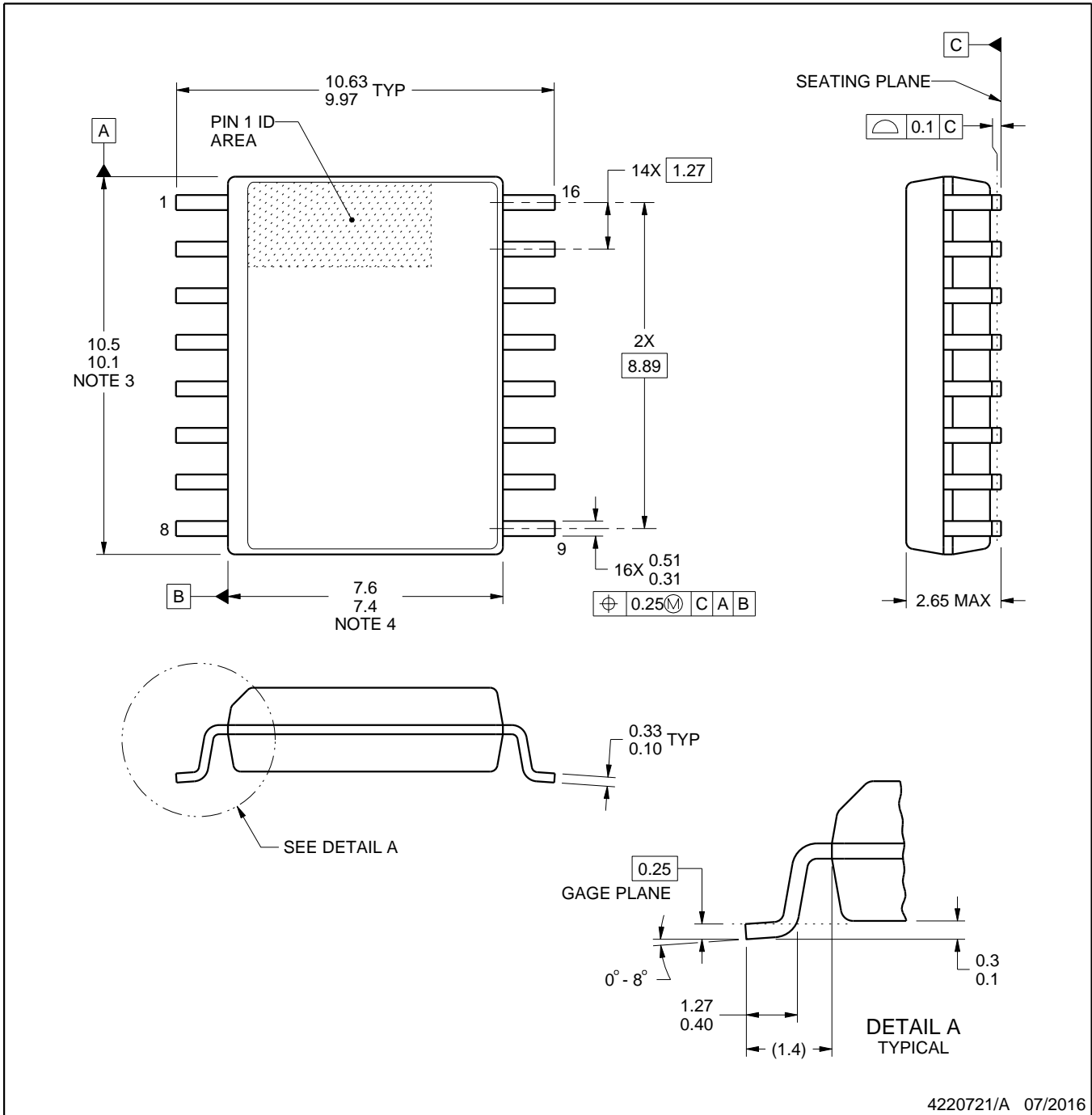

4220721/A 07/2016

### NOTES:

1. All linear dimensions are in millimeters. Dimensions in parenthesis are for reference only. Dimensioning and tolerancing per ASME Y14.5M.
2. This drawing is subject to change without notice.
3. This dimension does not include mold flash, protrusions, or gate burrs. Mold flash, protrusions, or gate burrs shall not exceed 0.15 mm, per side.
4. This dimension does not include interlead flash. Interlead flash shall not exceed 0.25 mm, per side.
5. Reference JEDEC registration MS-013.

# EXAMPLE BOARD LAYOUT

DW0016A

SOIC - 2.65 mm max height

SOIC

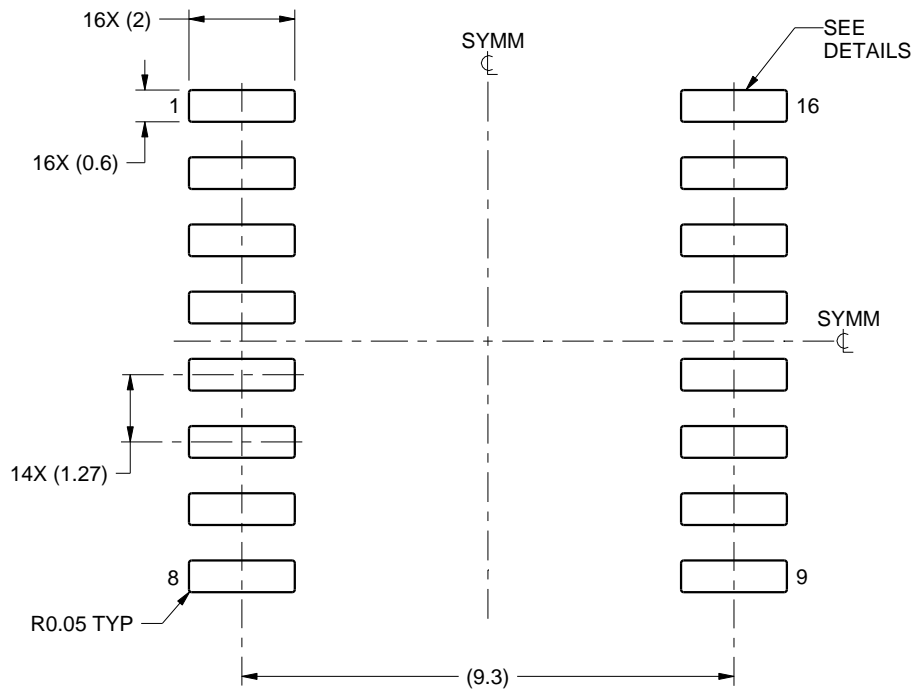

LAND PATTERN EXAMPLE  
SCALE:7X



SOLDER MASK DETAILS

4220721/A 07/2016

NOTES: (continued)

6. Publication IPC-7351 may have alternate designs.

7. Solder mask tolerances between and around signal pads can vary based on board fabrication site.

# EXAMPLE STENCIL DESIGN

DW0016A

SOIC - 2.65 mm max height

SOIC

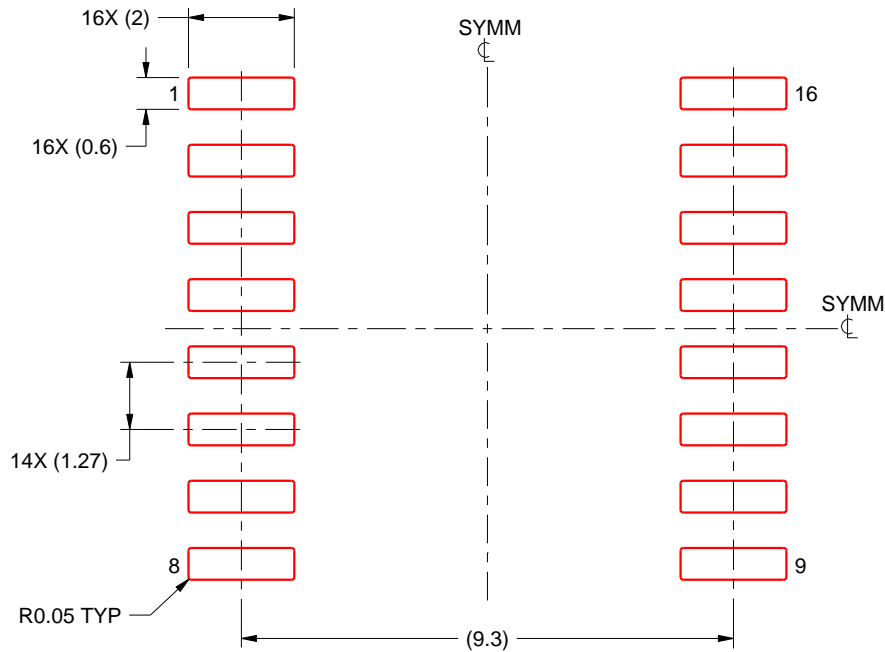

SOLDER PASTE EXAMPLE  
BASED ON 0.125 mm THICK STENCIL  
SCALE:7X

4220721/A 07/2016

NOTES: (continued)

8. Laser cutting apertures with trapezoidal walls and rounded corners may offer better paste release. IPC-7525 may have alternate design recommendations.
9. Board assembly site may have different recommendations for stencil design.

N (R-PDIP-T\*\*)

PLASTIC DUAL-IN-LINE PACKAGE

16 PINS SHOWN

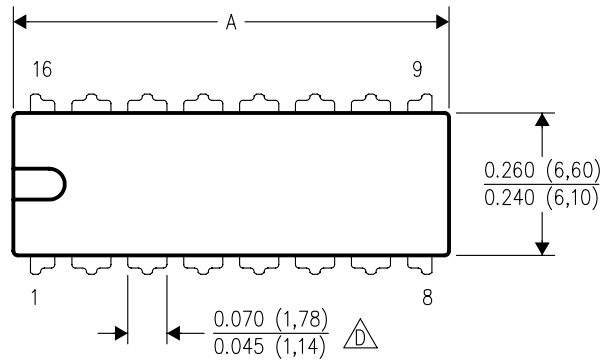

DIM	PINS **			
	14	16	18	20
A MAX	0.775 (19,69)	0.775 (19,69)	0.920 (23,37)	1.060 (26,92)
A MIN	0.745 (18,92)	0.745 (18,92)	0.850 (21,59)	0.940 (23,88)
MS-001 VARIATION	AA	BB	AC	AD

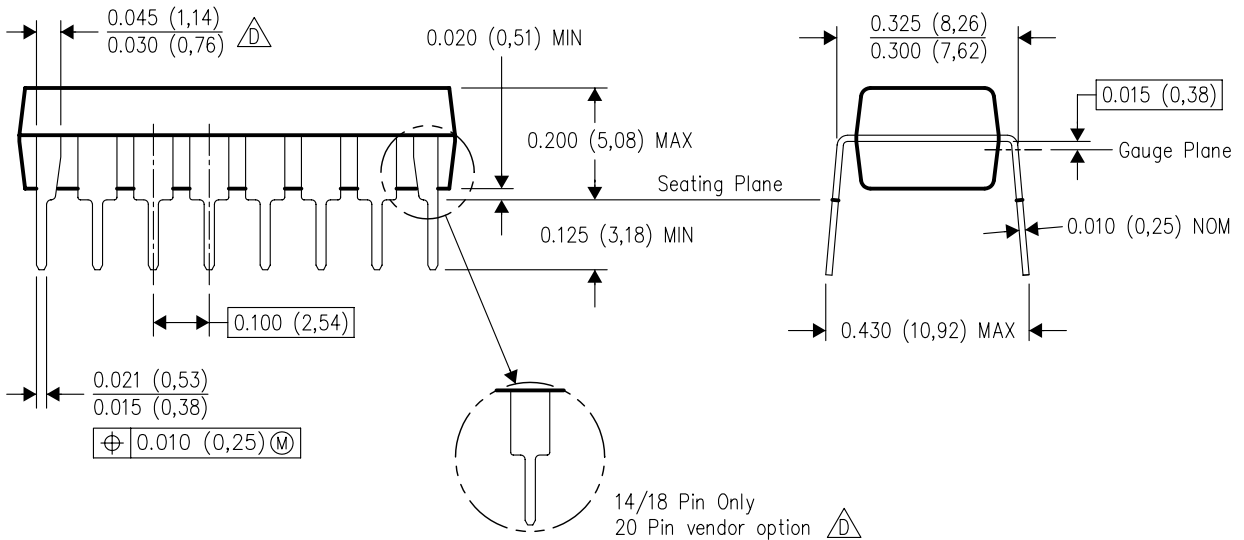

4040049/E 12/2002

- NOTES:
- A. All linear dimensions are in inches (millimeters).
  - B. This drawing is subject to change without notice.
  - Falls within JEDEC MS-001, except 18 and 20 pin minimum body length (Dim A).
  - The 20 pin end lead shoulder width is a vendor option, either half or full width.



# EXAMPLE BOARD LAYOUT

DW0020A

SOIC - 2.65 mm max height

SOIC



LAND PATTERN EXAMPLE  
SCALE:6X



SOLDER MASK DETAILS

4220724/A 05/2016

NOTES: (continued)

- 6. Publication IPC-7351 may have alternate designs.
- 7. Solder mask tolerances between and around signal pads can vary based on board fabrication site.

# EXAMPLE STENCIL DESIGN

DW0020A

SOIC - 2.65 mm max height

SOIC



SOLDER PASTE EXAMPLE  
BASED ON 0.125 mm THICK STENCIL  
SCALE:6X

4220724/A 05/2016

NOTES: (continued)

8. Laser cutting apertures with trapezoidal walls and rounded corners may offer better paste release. IPC-7525 may have alternate design recommendations.
9. Board assembly site may have different recommendations for stencil design.

## IMPORTANT NOTICE AND DISCLAIMER

TI PROVIDES TECHNICAL AND RELIABILITY DATA (INCLUDING DATASHEETS), DESIGN RESOURCES (INCLUDING REFERENCE DESIGNS), APPLICATION OR OTHER DESIGN ADVICE, WEB TOOLS, SAFETY INFORMATION, AND OTHER RESOURCES "AS IS" AND WITH ALL FAULTS, AND DISCLAIMS ALL WARRANTIES, EXPRESS AND IMPLIED, INCLUDING WITHOUT LIMITATION ANY IMPLIED WARRANTIES OF MERCHANTABILITY, FITNESS FOR A PARTICULAR PURPOSE OR NON-INFRINGEMENT OF THIRD PARTY INTELLECTUAL PROPERTY RIGHTS.

These resources are intended for skilled developers designing with TI products. You are solely responsible for (1) selecting the appropriate TI products for your application, (2) designing, validating and testing your application, and (3) ensuring your application meets applicable standards, and any other safety, security, or other requirements. These resources are subject to change without notice. TI grants you permission to use these resources only for development of an application that uses the TI products described in the resource. Other reproduction and display of these resources is prohibited. No license is granted to any other TI intellectual property right or to any third party intellectual property right. TI disclaims responsibility for, and you will fully indemnify TI and its representatives against, any claims, damages, costs, losses, and liabilities arising out of your use of these resources.

TI's products are provided subject to TI's Terms of Sale ([www.ti.com/legal/termsofsale.html](http://www.ti.com/legal/termsofsale.html)) or other applicable terms available either on [ti.com](http://ti.com) or provided in conjunction with such TI products. TI's provision of these resources does not expand or otherwise alter TI's applicable warranties or warranty disclaimers for TI products.

Mailing Address: Texas Instruments, Post Office Box 655303, Dallas, Texas 75265  
Copyright © 2019, Texas Instruments Incorporated

## Looking for pricing, stock, or lifecycle information?

Click below to explore more details on WIN SOURCE:

 [View SN65LBC174ADWR on WIN SOURCE](#)

 [Texas Instruments](#) Information

## Optimize Your Supply Chain with WIN SOURCE Solutions

-  Global Sourcing Solution
-  Obsolete Management
-  Cost Control Management
-  Shortage Management
-  Alternative Solution
-  Excess Inventory Management